



**JOINT IMPLEMENTATION PROJECT DESIGN DOCUMENT FORM**  
**Version 01 - in effect as of: 15 June 2006**

**CONTENTS**

- A. General description of the project
- B. Baseline
- C. Duration of the project / crediting period
- D. Monitoring plan
- E. Estimation of greenhouse gas emission reductions
- F. Environmental impacts
- G. Stakeholders' comments

**Annexes**

- Annex 1: Contact information on project participants
- Annex 2: Baseline information
- Annex 3: Monitoring plan
- Annex 4 : List of abbreviations

**SECTION A. General description of the project****A.1. Title of the project:**

Associated petroleum gas recovery at Priobskoe oil field of “Rosneft”

Sectoral scopes: 1 (Energy industries) and 10 (Fugitive emissions from fuels)

Version 1.2

21/07/2011

**A.2. Description of the project:**

Priobskoe oil field is one of the largest reservoirs of oil in Russia and in the world. It is situated in Khanty-Mansiysky Autonomous District near the town of Khanty-Mansiisk, and divided by Ob River into the left-bank and the right-bank parts. The left-bank part is being developed since 1988, and the right-bank part is being developed since 1999.

LLC “RN-Uganskneftegas” develops the north part of Priobskoe oil field. This part belongs to OJSC “Oil Company “Rosneft”. The remaining mineable reserves of category ABC1+C2 were estimated at 500 million tons as of January 1, 2009. Annual extraction in 2009 peaked at 33,836.8 thousand tons in 2009 and somewhat decreased in 2010.

The goal of the proposed project is to reduce the environmental impacts by implementing the program of utilization of Associated Petroleum Gas (APG) which had been previously flared.

**Situation existing prior to the starting date of the project**

Before project implementation the associated petroleum gas produced by LLC “RN-Uganskneftegas” at Priobskoe oil field was mostly flared in the flares of oil collection and preparation installations. The products of its combustion including CO<sub>2</sub>, methane, nitrous oxides, soot, some other substances typical for APG flaring were released into the atmosphere and created negative impact for the global and local environment and human health.

**Project scenario**

Rosneft implemented measures aimed at reduction of APG flaring at Priobskoe oil field between 2007 and 2011. Company has chosen following directions to utilize flared APG: (i) APG compression and transportation to Yuzhno-Balyksky gas processing plant of Sibur company (YB GPP), (ii) utilization of APG as a fuel for electricity generation at the largest in Russia 315 MW gas turbine power plant to be constructed at Priobskoe oil field.

The first direction was in fact implemented at the end of 2007, when a new 167-km long pipeline was constructed. The compressor station #1 (CS-1) was commissioned in November 2007 and boosted APG through the pipeline. YB GPP processes APG into dry stripped gas and heavier hydrocarbon fractions. Dry stripped gas is pumped to the main pipeline of OJSC Gazprom, while the hydrocarbon fractions are used as fuel and raw material for upstream processing. OJSC Sibur is the owner of YB GPP and one of the largest petrochemical enterprises in Russia and Eastern Europe.

Collection of APG in the right-bank part of Priobskoe oil field will be launched in August of 2011, when the compressor station #2 (CS-2) will be commissioned.

To implement a second direction, during the period 2009-2011 at Priobskoe oil field will be constructed:

- Gas Turbine Power Plant (GTPP) equipped with seven 45 MW Siemens gas turbines SGT-800 being commissioned in three stages, and



- Gas Treatment Installation (GTI), which extracts gaseous methane-ethane fraction from raw APG, being commissioned in two stages. The methane-ethane fraction of APG is burned in GTPP gas turbines while the remaining condensed liquid hydrocarbon fractions are mixed with oil in the pipeline.

Thus OJSC “Oil Company “Rosneft” will be capable to provide technically feasible level of utilization of APG produced at Priobskoe oil field.

Despite the fact that OJSC “Oil Company “Rosneft” financed construction of infrastructure at Priobskoe oil field for APG recovery, preparation and compressing under the proposed project this company cannot claim its rights to the whole amount of the Emission Reduction Units (ERU) generated in the course of implementation of Priobskoe oil field Gas program in the framework of the present project. The reason is that OJSC “Sibur” has passed necessary JI procedures and obtained an approval from the Ministry of Economic Development of the Russian Federation (Designated Focal Point) to implement a Joint Implementation project “Processing of associated petroleum gas at Yuzhno-Balyksky gas processing plant”<sup>1</sup>. This project considers all APG which is piped to YB GPP from Priobskoe oil field in 2009-2012 as flared under the baseline.

To avoid double counting all APG which is delivered to YB GPP from Priobskoe oil field in 2009-2012 and associated ERUs are excluded from consideration in this PDD. However since the crediting period in the original PDD of JI project implemented at YB GPP did not include year 2008 the emission reduction achieved by processing of APG at YB GPP instead of flaring in 2008 was considered in the present project proposed by OJSC “Oil Company “Rosneft”.

Therefore as a result of project implementation the ERUs in the amount of 3,900,810 tons CO<sub>2</sub>-eq. will be generated in 2008-2012.

### **Baseline scenario**

In the absence of the proposed JI project the flaring of APG at Priobskoe oil field would continue, because implementation of the Gas program would have required considerable investments by OJSC “Oil Company “Rosneft”, and it would not be economically viable for the company (see Section B.2). The company would invest its financial resources in exploration of Priobskoe oil field and expansion of oil extraction rather than in implementation of this project.

### **Short description of JI project history**

Project implementation became possible only by means on flexible mechanism of Joint Implementation under the Kyoto Protocol. Rosneft made its internal decision to implement this project in 2006, and began full-scale financing of project activities, because after development of technical design documentation for CS-1 in 2003 the project implementation was suspended. The decision to arrange the project by JI mechanism was made together with the similar decision on the other large-scale projects of Rosneft (Kharamur, Komsomolskoe), that have received already an approval as JI projects from Russian Designated Focal Point.

---

<sup>1</sup> [https://www.sberbank.ru/common/img/uploaded/files/tender/kioto2/32\\_PDD\\_Снбгп.pdf](https://www.sberbank.ru/common/img/uploaded/files/tender/kioto2/32_PDD_Снбгп.pdf)

**A.3. Project participants:**

Table A 3.1. Project participants

<u>Party involved</u>	<u>Legal entity project participant</u> (as applicable)	Please indicate if the <u>Party involved</u> wishes to be considered as <u>project participant</u> (Yes/No)
Party A: (host) Russian Federation	OJSC “Oil Company “Rosneft”	No
Party B: Netherlands	Carbon Trade & Finance SICAR S.A.	No

**OJSC “Oil Company Rosneft”** is the leader of Russia’s petroleum industry, and ranks among the world’s top publicly traded oil and gas companies. The company is primarily engaged in exploration and production of hydrocarbons, production of petroleum products and petrochemicals, and marketing of outputs. Rosneft has been included in the Russian Government’s List of Strategic Enterprises and Organizations. The state holds 75.16% in the Company (through OJSC ROSNEFTEGAZ), while approximately 15% of shares are in free-float.

Rosneft is widely engaged in exploration and production across all key hydrocarbon regions of Russia: Western Siberia, Southern and Central Russia, Timan-Pechora, Eastern Siberia and the Far East. In addition the company participates in several exploration projects in Kazakhstan and Algeria. Rosneft’s seven major refineries are conveniently located throughout the country, from the Black Sea coast to the Far East, and the Company’s retail network covers 39 regions of the Russian Federation<sup>2</sup>.

LLC “RN-Uganskneftegas” is Rosneft’s largest oil-producing enterprise. It develops 26 oil fields in the Khanty-Mansiysk Autonomous District of Western Siberia. Uganskneftegas was established in 1977, and in early 2005 it was acquired by Rosneft and fully integrated into the company’s production infrastructure.

Uganskneftegas’s fields account for approximately 16% of Western Siberia’s total recoverable oil reserves. Over 80% of Uganskneftegas proved oil reserves are concentrated in the Priobskoe, Mamontovskoye, Malobalykskoye, and Prirazlomnoye fields. Uganskneftegas has significant potential to further increase its hydrocarbon reserves and crude oil output through additional exploration of deep strata and those overlooked at earlier stages of exploration. The reserve-to-production ratio at Uganskneftegas equals 23 years, which is well above the global industry’s average<sup>3</sup>.

**Carbon Trade & Finance SICAR S.A.** is a joint venture of Gazprombank (Russia) and Commerzbank (Germany). This joint venture was established to facilitate investments in rapidly developing greenhouse gas emission reduction markets. The company is registered in Luxemburg and invests in greenhouse gas emission reduction projects in Russia and CIS countries.

Carbon Trade & Finance SICAR S.A. offers complex solutions to its customers: from risk management and consultations on carbon project financing to direct procurement of emission reduction units. Carbon Trade & Finance SICAR S.A. develops financial derivative products for financial institutions, governments and buyers, which have accepted binding emission reduction obligations. Carbon Trade & Finance SICAR S.A. has established its subsidiary CTF Consulting LLC in Moscow, which offers a

<sup>2</sup> <http://www.rosneft.com/about/Glance/>

<sup>3</sup> [http://www.rosneft.com/Upstream/ProductionAndDevelopment/western\\_siberia/Uganskneftegas/](http://www.rosneft.com/Upstream/ProductionAndDevelopment/western_siberia/Uganskneftegas/)

comprehensive portfolio of consulting services in the area of JI project development, preparation and support.

Carbon Trade & Finance SICAR S.A. is a buyer of ERUs generated by the proposed Project.

**A.4. Technical description of the project:****A.4.1. Location of the project:**

Urals Federal District, Khanty-Mansiisky Autonomous District - Ugra, Priobskoe oil field.

**A.4.1.1. Host Party(ies):**

Russian Federation

**A.4.1.2. Region/State/Province etc.:**

Khanty-Mansiisky Autonomous District is the subject of the Russian Federation with population 1,538,600 people (2010) and area 534,800 km<sup>2</sup>; it is the historic dwelling of small indigenous folks of Khanty and Mansi. There are 106 municipalities in this district. The town of Khanty-Mansiisk is the administrative capital of the district.

Figure A.4.1.2-1. Khanty-Mansiisky Autonomous District on the map of the Russian Federation

**A.4.1.3. City/Town/Community etc.:**

Priobskoe oil field. LLC “RN-Uganskneftegas”, Oil Treatment and Transit Workshop (OTTW) #7. CS-1 and GTPP sites. Latitude: 61.100789. Longitude: 70.197144 (Source: Google Maps).<sup>4</sup>

**A.4.1.4. Detail of physical location, including information allowing the unique identification of the project (maximum one page):**

Khanty-Mansiisky Autonomous District - Ugra occupies the central part of West-Siberian Plain, which is one of the largest plains in the world. The largest Russian rivers Ob and Irtysh flow from the south to the north across this district.

Khanty-Mansiisky Autonomous District is located in the forested area, and mainly covered by waterlogged taiga. More than 25,000 lakes are scattered across the taiga and wetlands.

The climate is strongly continental. The winter is long and cold; strong winds and blizzards are frequent. Late spring and early autumn are often marked by recurrent frosts. The summer is rather short but warm,

<sup>4</sup> <http://maps.google.com/>

there is plenty of sunlight. The weather is highly unstable with frequent winds. Snow season with temperatures below zero Celsius degrees lasts for 5-6 months.<sup>5</sup>

The largest in West Siberia Priobskoe oil field is situated within Khanty-Mansiysky Autonomous District about 65 km far away from Khanty-Mansiysk and 200 km far away from Nefteyugansk.

Sixty percent of the territory of Priobskoe oil field is occupied by Ob river floodplain, which poses special requirements for construction of well clusters, pressure piping and underwater sections of pipelines.

Figure A.4.1.4.1 Infrastructure of RN-Uganskneftegas at Priobskoe oil field.



#### **A.4.2. Technology(ies) to be employed, or measures, operations or actions to be implemented by the project:**

The proposed project is aimed at recovery of associated petroleum gas at Priobskoe oil field.

The following infrastructure is being constructed for this project:

1. Gas pipelines for collection and transportation of APG from oil separators to CS-1 and CS-2; from CS-1 and CS-2 to GTI and GTPP; gas pipeline for transportation of APG to YB GPP.
2. Compressor stations CS-1 and CS-2 with gas turbine drive. Russian turbines *GPA-12DKS "Urals"* are installed at CS-1 and *GPA-10DKS-08 "Urals"* are installed at CS-2. These turbines are fueled by the pumped APG.

CS-1 input capacity is 1.84 billion m<sup>3</sup> of APG per year; its output pressure is 6.3 MPa, which has to be higher than the intake pressure of YB GPP ( $\geq 3.2$  MPa). Commercial gas capacity of CS-1 is 1.5 billion m<sup>3</sup>/year. Technological scheme of CS-1 consists of the three identical technological lines. Each line contains a gas dewatering unit positioned at the intermediate pressure stage, before the second compressing stage.

CS-2 input capacity is 1.5 billion m<sup>3</sup>/year. The compressed and dewatered APG from CS-2 is supplied to:

- GTPP of Priobskoe oil field taking in account that the gas topping pressure is maintained at 3.2 MPa;
- the intake of CS-1 and then transported to YB GPP.

<sup>5</sup> <http://www.admhmao.ru/obsved/index.htm>



### 3. Compressor stations of APG of final separation stages with electric drive (4 units)

These compressor stations belong to the oil preparation facility. Their function is to compress APG, which is separated at the final separation stages under 0.5-0.05 kgf/cm<sup>2</sup> pressure. After these units the APG is dewatered and supplied to the TAKAT 50.07 compressors. After these compressors the APG with temperature 90<sup>0</sup>C and pressure 7 kgf/cm<sup>2</sup> is cooled by the air coolers down to 40<sup>0</sup>C and transported to the discharge separators to filter out the condensate and moisture which condenses during cooling. Then this gas is supplied to the gas pipeline.

Low pressure compressor station at Buster Pump Station (BPS) of Preliminary Water Discharge Unit (PWDU) at cluster 201 and low pressure compressor station at OTTW-8 supply gas to the intake of CS-2 which is located in the right-bank part of Priobskoe oil field.

Low pressure compressor station at BPS of PWDU of cluster 285 and low pressure compressor station at OTTW-7 supply gas to the intake of CS-1 which is located in the left-bank part of Priobskoe oil field.

### 4. Gas treatment installation

Gas treatment installation (GTI) processes APG of Priobskoe oil field, so it can be used as a fuel by GTPP. During the first phase of the project the GTI will be used for treatment of gas coming from CS-1 of the left-bank part of Priobskoe oil field. During the second stage, after CS-2 is commissioned, this GTI will treat APG coming from the right-bank part of Priobskoe oil field. The hydrocarbon condensate recovered by GTI will be pumped in the oil pipeline laid through Prirazlomnoe oil field, or to OTTW-7 of Priobskoe oil field.

The first stage of GTI plant consists of one production line with gas capacity of 600 million m<sup>3</sup>/year, which applies low-temperature separation technology. The second stage of the plant has the same capacity; it applies low-temperature condensation technology. The first stage can be converted to low-temperature condensation technology in the future.

Total capacity of GTI after commissioning of the second stage of the plant shall reach 1.2 billion m<sup>3</sup>/year of processed APG per year. The remaining volume of gas unused by GTPP will be supplied from GTI to CS-1 and then to YB GPP.

### 5. Priobskoe GTPP with installed capacity 315 MW

Priobskoe GTPP is designed to supply electricity for oil exploration activities at Priobskoe oil field. The main fuel for GTPP is APG which is treated at GTI. The reserve fuel is natural gas supplying by a gas main.

Projected installed capacity of Priobskoe GTPP is 315 MW and its available capacity is 252 MW; the difference provides a margin of safety to ensure proper operations during planned maintenance or emergency shutdowns.

Priobskoe GTPP supplies electricity with voltage 110 kV to the external consumers and consumes electricity with voltage 10 kV or 0.4 kV for its own needs. This power plant also uses cogenerated heat energy in form of hot water for own heating purposes.

Produced and supplied electricity meets “Russian quality standards for electricity supplied to general purpose electricity grids” (GOST 13109-97) and is fed to the consumers through a 27-cell 11 kV outdoor switchgear (OS) and the block transformers.

Several high-voltage transmission lines (HVL) connect GTPP with the substations serving power needs on Uganskneftegas as follows: 4 lines with Rosliakovskaya substation; 2 lines with Monastyrskaya substation; 2 lines with Shubinskaya substation and 2 lines with Zenkovo substation.



GTPP generating capacity consists of seven Siemens SGT-800 Gas-Turbine Units (GTU) with nominal power capacity 45 MW each. These heavy-duty industrial turbines are very reliable and efficient; they have low emissions due to application of the newest turbine-building technologies. SGT-800 turbine has a single-shaft engine with 15-stage compressor, the first three compressing stages have variable geometry. The temperature in the combustion chamber may reach 1,200°C.

Full-load gas consumption of GTU is 13,000 m<sup>3</sup>/hour, which is equivalent to 351 grams of equivalent fuel per kWh of electricity generated by GTPP. Annual consumption of APG by fully operational GTPP will reach 700 million m<sup>3</sup>, and annual electricity generation will be 2.3 billion kWh.

Table A.4.2-1 Project implementation schedule

Month and year	Commissioned equipment
Equipment already commissioned by PDD development date	
November 2007	CS-1
December 2009	GTPP first stage (GTU 1,2,3)
June 2010	GTPP second stage (GTU 7)
July 2010	GTI first stage
Expected	
August 2011	CS-2; GTI second stage; GTPP third stage (GTU 4,5,6)

**A.4.3. Brief explanation of how the anthropogenic emissions of greenhouse gases by sources are to be reduced by the proposed JI project, including why the emission reductions would not occur in the absence of the proposed project, taking into account national and/or sectoral policies and circumstances:**

Associated petroleum gas is a mixture mainly consisting of saturated hydrocarbons C<sub>1</sub>-C<sub>6</sub>. In the absence of the proposed project almost all APG released during oil separation would be flared in the flares of oil collection and preparation facilities; only a small fraction of APG would be used for own needs of the enterprise: in boilers, oil preheating furnaces, etc. APG flaring leads to atmospheric emissions of greenhouse gases: CO<sub>2</sub> and CH<sub>4</sub> (methane). Methane is emitted during incomplete combustion of APG. Incomplete combustion can be either detected instrumentally or visually, when the released soot is easily observed ("sooty burning").

Recovery of APG as an energy source substituting fossil fuels will replace its useless flaring and thus reducing GHG emissions.

Dewatered stripped gas (an analog of natural gas) and Broad Fraction of Light Hydrocarbons (BFLH) shall be produced from APG at YB GPP. The BFLH is used as raw material (similar to crude naphtha) in petrochemical industry.

Priobskaya GTPP will cover the power demand of consumers of the oil field where it is located thereby the electricity generated on APG will replace the electricity generated from fossil fuels by the power plants of UES Urals. Moreover the combustion of APG in the gas turbines is performed efficiently without methane release, and transmission losses of electricity will be minimized due to closest location of GTPP.

APG flaring is very common in Russia. Actual volumes of flared APG are difficult to estimate because of imperfectness of the existing methodologies and the absence of monitoring equipment. Most of the oil companies report rough estimates of the flared amounts of gas because there is no direct monitoring.



Vladimir Putin made a statement with this regard to the Federal Assembly on 26.04.2007 that about 20 billion m<sup>3</sup> of APG being annually flared in Russia. At the same time according to State Federal Statistical Service the amount of flared APG in 2000-2008 could be anywhere between 6 and 13 billion m<sup>3</sup> per annum and there is an upward trend.

On the other hand remote sensing data of United States National Oceans and Atmosphere Agency (NOAA) indicated that 40.2 billion m<sup>3</sup> of APG was flared in Russia in 2008, which represented about 35% of APG globally flared during that year (<http://web.worldbank.org>).

Cross-checks of data obtained from diverse sources (Solovianov, 2008) and the analysis of Russian Gas Society showed that 20 billion m<sup>3</sup> was the best estimate of the volume of APG flared in Russia in 2008.<sup>6</sup>

The Decree of Russian Government #7 of 08.01.2009 set up the target to reduce APG flaring to 5% of recovered volume by 01.01.2012. This target should have provided incentives for oil companies to develop the projects of APG utilization. However this Decree only increased the penalty for exceeding the upper allowed limit of APG flaring (5%). An oil company's decision about each individual APG utilization project is based upon indicators of its economic profitability. It is quite likely that the abovementioned decree will be called off in the near future.<sup>7</sup> Russian Federal legislation does not explicitly forbid APG flaring neither such legislation is expected in the foreseeable future.

This is why Emission Reduction Units generated by this project provided an incentive for implementation of this project by Rosneft (please refer to Section B.2 for more details).

#### **A.4.3.1. Estimated amount of emission reductions over the crediting period:**

Table A.4.3.1. Estimated amount of emission reductions over the crediting period of 2008-2012

	Years
Length of the <u>crediting period</u> :	5 years
Year	Estimate of annual emission reductions in tonnes of CO <sub>2</sub> equivalent
2008	985 649
2009	0
2010	180 190
2011	1 102 832
2012	1 632 138
Total estimated emission reductions over the <u>crediting period</u> (tonnes of CO <sub>2</sub> equivalent)	3 900 810
Annual average of estimated emission reductions over the <u>crediting period</u> (tonnes of CO <sub>2</sub> equivalent)	780 162

Table A.4.3.1-2 Estimated amount of emission reductions over the crediting period of 2013-2020 (if the extension of crediting period for this project is approved by the Russian Federation)

<sup>6</sup> WWF Russia «Problems and perspectives of utilization of associated petroleum gas in Russia», 2010. <http://www.wwf.ru/data/pub/energy/gases-full-inet.pdf>

<sup>7</sup> <http://www.kommersant.ru/doc/1640995?isSearch=True>



	Years
Length of the commitment period:	8 years
Year	Estimate of annual emission reductions in tonnes of CO <sub>2</sub> equivalent
2013	1 465 363
2014	1 423 669
2015	1 482 531
2016	1 445 742
2017	1 450 647
2018	1 440 837
2019	1 433 479
2020	1 433 479
Total estimated emission reductions over the <u>crediting period</u> (tonnes of CO <sub>2</sub> equivalent)	11 575 747
Annual average of estimated emission reductions over the <u>crediting period</u> (tonnes of CO <sub>2</sub> equivalent)	1 446 968

**A.5. Project approval by the Parties involved:**

Russian Federation as a Host Party issues the approval for JI project only after receipt of the opinion from the Accredited Independent Entity (AIE) that project complies with established requirements.

The second approval for the project will be received in Netherlands.

**SECTION B. Baseline****B.1. Description and justification of the baseline chosen:**

According to Appendix B to Decision 9/CMP.1 (refer to the Report of the Conference of the Parties serving as the meeting of the Parties to the Kyoto Protocol on its first session, held at Montreal from 28 November to 10 December 2005.) and JI Guidance on criteria for baseline setting and monitoring, Version 02, Project developer has decided to use JI specific approach for description and justification of the selected baseline. This JI specific approach comprises the following steps:

**Step 1. Identification and description of the approach chosen regarding baseline setting**

Project developer applies JI specific approach for description and justification of the selected baseline. This is based on the requirements of Paragraph 9(a) of JI Guidance on criteria for baseline setting and monitoring, Version 02.

*A baseline was identified by listing and describing plausible future scenarios on the basis of conservative assumptions and selecting the most plausible one.*

The following rules have been applied for description of the most plausible baseline scenario:

1. Selection of feasible alternatives which could potentially serve as a baseline;
2. Justification of elimination of less likely alternatives, due to either technical or economical reasons, or both.

All alternatives have been described and the most plausible alternative has been selected as the baseline.

For the establishing of the baseline and further development of additionality proofs in the section B.2 it was directly taken into account:

- State policy and legislation in the oil and gas sector.

It is the responsibility of the State to develop decision making procedures for selection appropriate APG utilization options taking into account economic and other considerations; to determine the desired share of APG and the products derived from APG in the gas-supplying sector of national economy; to create nondiscriminatory conditions for market suppliers of APG and the products of its chemical processing; to conduct a balanced price policy; to enforce licensing policy in the area of subsoil utilization, to provide economic incentives and enforcement mechanisms for practical implementation of APG utilization projects and monitoring of APG release.

The current PDD takes in account the existing situation and historic conditions when setting the baseline for the proposed project. These conditions include the regulatory role of the State in the area of APG utilization and utilization efficiency (please refer to Section B.2 for details).

- Economic situation in Russian oil and gas sector and projected demand.

Oil extraction is one of the most important sources of income for the state budget of Russian Federation. As the nationwide rate of oil extraction tends to increase any decreases in oil extraction rates at particular oil fields are usually caused by depletion of oil reserves. Associated petroleum gas is a by-product of oil extraction and its recovered volume depends both on (i) the oil extraction rate and the (ii) changes in the amount of dissolved gas in the oil. This amount is called “gas factor” and in turn depends on geological conditions directly related to oil extraction.

This is why the volumes of APG recovered at Priobskoe oil field are the same in the baseline and project scenarios, as the project activities aim at providing technical solutions for utilization of APG already after its segregation during oil separation process.

- Technical aspects of APG utilization



Flaring of APG historically is used as the safest method to get rid of surplus associated gas. There are no technical barriers to APG flaring at Priobskoe oil field.

- Availability of capital and analysis of investment barriers typical for OJSC “Oil Company “Rosneft”

This aspect is addressed in the analysis of additionality of the proposed project

- Local availability of technology and equipment

Russian company OJSC “Iskra” manufactures the primary equipment for CS-1 and CS-2. This machine-manufacturing company is located in Perm. It was founded in 1955 for development and production of missilery and has been manufacturing gas compressors since 1995.<sup>8</sup>

The gas turbines manufactured by Siemens are the core equipment of GTPP. Siemens is a world leader in development and production of the equipment for energy sector. Siemens experts provide consulting support and training courses for local experts, maintenance services for their clients at all stages of project implementation, including design, planning, and reconstruction, warranty repairs and after-guarantee services.

It may be concluded that project technology and equipment are readily available.

- Price and availability of fuel and electricity

Associated petroleum gas is a fuel and a raw material for petrochemical industry at the same time. It has been always used to cover own heat energy demands of the enterprise (as a fuel for oil preheating furnaces, boilers, etc.) but its recovery requires significant capital expenditures from the enterprise. These expenditures arise from construction of gas transporting infrastructure, gas treatment and conditioning facilities and electricity generation capacities. Economic aspects of project implementation are discussed in Section B.2. Before project implementation start, Priobskoe oil field was connected to the grid of TiumenEnergо and did not experience any deficit of electricity.

## **Step 2. Application of the approach chosen**

The following feasible and realistic alternatives were identified and considered as potential candidates for the baseline scenario:

Alternative 1: Flaring of APG at Priobskoe oil field and consumption of electricity purchased from UES Urals grid;

Alternative 2: Implementation of APG utilization project at Priobskoe oil field as described in section A.2., without its registration as a Joint Implementation project;

Alternative 3: Implementation of APG utilization project at Priobskoe oil field by other design like:

- A. Denial of construction of Priobskaya GTPP and pumping of all amount of compressed APG to Yuzhno-Balyksky GPP of Sibur,
- B. Construction of own gas processing plant at the Priobskoe oil field,
- C. Connection of the Priobskoe oil field with the gas main of Gazprom and delivery of the APG into the national gas distribution system without prior processing.

Other potential alternatives like introduction of the gas-lift system at Priobskoe oil field, injection of the APG into oil reservoir or production of liquefied natural gas from APG are assumed to be initially technically not feasible or senseless from economic point of view and therefore were not seriously considered.

---

<sup>8</sup> [http://www.npoiskra.ru/file/reference\\_gas\\_transfer\\_2010.pdf](http://www.npoiskra.ru/file/reference_gas_transfer_2010.pdf)



*Elimination of alternatives not complying with existing regulations*

Russian legislation does not pose any barriers to realization of these alternatives, thus none of alternatives can be eliminated as those, not complying with existing regulations.

*Elimination of unlikely alternatives (either technically or economically)*

Alternative 1 had been taking place at Priobskoe oil field until November 2007. This alternative did not require any additional capital costs and was not prohibited by Russian legislation since flaring of APG in Russia was quite common (please refer to Section A.4.3).

Alternative 2 is not financially viable for OJSC "Oil Company "Rosneft". It requires significant additional investments which project owner would have rather directed into expansion of oil extraction infrastructure. Investment analysis has been conducted to prove additionality of this option, please refer to Section B.2.

Alternative 3 does not principally differs from Alternative 2 in the aspect of utilization of the flared APG especially taking into account the approach applied in this PDD for the year 2008, and also require significant additional investments. Therefore all three mentioned variations could be also considered as potential JI project. However taking into account various barriers (main of them are analyzed in section B.2. of this PDD) and economic criteria Rosneft has decided to work out a design of the Gas programme of Priobskoe oil field as described in section A.2., i.e. Alternative 2.

**Conclusions and description of selected baseline:**

Alternative 1 was selected as the baseline:

***Flaring of APG at Priobskoe oil field and consumption of electricity purchased from UES Urals grid***

Selection of *Alternative 1* scenario as the baseline meets IPCC Guidance on criteria for baseline setting and monitoring, version 02, in particular:

*The baseline covers all GHG emissions, which are under control of project participants, substantial in their volumes, and correctly determined in the project.*

The baseline includes CO<sub>2</sub> and CH<sub>4</sub> emissions from flaring of APG which was supplied to YB GPP in 2008 and APG supplied as a fuel gas to Priobskaya GTPP, and CO<sub>2</sub> emissions from production of electricity by UES Urals power plants, in the amount equivalent to electricity output by Priobskaya GTPP in 2009-2012.<sup>9</sup>

**Baseline emission calculation methodology**

The following approaches were applied during baseline CO<sub>2</sub> emission calculations:

For year 2008:

---

<sup>9</sup> Under the proposed project OJSC "Oil Company "Rosneft" cannot claim its rights to the Emission Reduction Units (ERU) generated in the course of implementation of Priobskoye oil field gas program in the framework of the present project. The reason is that OJSC "Sibur" has obtained an approval from the Ministry of Economic Development of the Russian Federation to implement a Joint Implementation project "Processing of associated petroleum gas at Yuzhno-Balyksky gas processing plant". This project considers all APG which is piped to YB GPP from Priobskoye oil field in 2009-2012 as flared under the baseline.

To avoid double counting all APG which is piped to YB GPP from Priobskoye oil field in 2009-2012 and associated ERUs are excluded from consideration in the PDD. However since the crediting period in the original PDD of JI project implemented at YB GPP did not include year 2008 the emission reduction achieved by processing of APG at YB GPP instead of flaring in 2008 was considered in the present project proposed by OJSC "Oil Company "Rosneft".



1. Based on measured volume and chemical composition of APG supplied to YB GPP of OJSC “Sibur” the weight of carbon was calculated. It was then converted to equivalent amount of CO<sub>2</sub> to be released to the atmosphere during flaring of this gas;
2. Incomplete combustion of APG in flares means that certain fraction of APG is released to the atmosphere without oxidation. IPCC Guidelines (2006) estimated the efficiency of flaring as 98%. The remaining 2% of APG is emitted directly to the atmosphere which causes the atmospheric emission of methane.<sup>10</sup> Applying the volume of APG supplied to YB GPP, its chemical composition and global warming potential of methane the equivalent emissions of CO<sub>2</sub> from incomplete combustion of APG were estimated.

For the period 2009-2012:

3. Based on measured volume and chemical composition of APG, which is treated in GTI and supplied to GTPP as a fuel the weight of carbon was calculated. It was then converted to the equivalent amount of CO<sub>2</sub> to be released in the atmosphere during flaring of this gas;
4. Similar to described in item (2) applying the volume of APG supplied to GTPP, chemical composition of this gas and global warming potential of methane, the equivalent emissions of CO<sub>2</sub> from incomplete combustion of APG were estimated.
5. Using the data on actual net output of electricity from Priobskaya GTPP and CO<sub>2</sub> emission factor for electricity produced by power plants of UES Urals as well as the percentage of losses during transmission and distribution of grid electricity, the equivalent CO<sub>2</sub> emissions during electricity production by UES Urals power plants under the baseline were estimated.

The equations describing above mentioned approaches are presented in the Section D.1.1.4.

Compression of APG at CS-1 and its treatment in GTI leads to formation of hydrocarbon condensate and light hydrocarbons multicomponent mixture (LHMM). These components, separated from the original APG, are delivered to the oil pipeline and mixed with oil. Although these heavy fractions of APG would have been flared under the baseline, they were not included in calculations of the baseline CO<sub>2</sub> emissions. This is a conservative assumption.

#### Key information and data used to establish the baseline

<b>Data/parameter</b>	FC <sub>APG, YBGPP</sub>
Data unit	Million m <sup>3</sup>
Description	Volume of APG, supplied to YB GPP in 2008
Time of <u>determination/ monitoring</u>	Monthly
Source of data (to be) used	Certificate of Acceptance signed by representatives of OJSC YB GPP and RN-Uganskneftegas LLC.
Value of data applied (for ex ante calculation/ determinations)	Not applicable
Justification of the choice of data or description of measurement methods and procedures (to be) applied	This parameter is required to calculate emissions from APG flaring in the baseline in 2008
QA/QC procedures (to be) applied	See Section D.2.
Any comment	No additional comments

<b>Data/parameter</b>	Y <sub>i, APG</sub>
-----------------------	---------------------

<sup>10</sup> National greenhouse gas inventory guidelines, IPCC, 2006. Vol 2, Section 4, p. 4.45.



Data unit	vol %
Description	The volumetric fraction of component in the APG
Time of <u>determination/ monitoring</u>	Monthly
Source of data (to be) used	Passport for supplied gas, signed by the head of the laboratory
Value of data applied (for ex ante calculation/ determinations)	Not applicable
Justification of the choice of data or description of measurement methods and procedures (to be) applied	This parameter is required to calculate emissions from APG flaring in the baseline in 2008
QA/QC procedures (to be) applied	See Section D.2.
Any comment	No additional comments

<b>Data/parameter</b>	FC <sub>APG treated</sub>
Data unit	million m <sup>3</sup>
Description	Consumption of treated APG by GTPP
Time of <u>determination/ monitoring</u>	Monthly
Source of data (to be) used	APG Acceptance Certificate (Supply-Delivery of APG) signed by the representatives of RN-Energo LLC. in Khanty-Mansiisky Autonomous District and RN-Uganskneftegas LLC.
Value of data applied (for ex ante calculation/ determinations)	Not applicable
Justification of the choice of data or description of measurement methods and procedures (to be) applied	This parameter is required to calculate emissions from APG flaring in the baseline during 2010-2012
QA/QC procedures (to be) applied	See Section D.2.
Any comment	No additional comments

<b>Data/parameter</b>	Y <sub>i</sub> APG treated
Data unit	vol %
Description	The volumetric fraction of component in the treated APG
Time of <u>determination/ monitoring</u>	Monthly
Source of data (to be) used	Certificate of chemical composition of APG signed by the head of the laboratory
Value of data applied (for ex ante calculation/ determinations)	Not applicable
Justification of the choice of data or description of measurement methods and procedures (to be) applied	This parameter is required to calculate emissions from APG flaring in the baseline during 2010-2012
QA/QC procedures (to be) applied	See Section D.2.



applied	
Any comment	No additional comments

<b>Data/parameter</b>	EG <sub>GTPP</sub>
Data unit	kWh
Description	Net output of the power produced by GTPP
Time of determination/ monitoring	Monthly
Source of data (to be) used	Report on power production at GTPP of Priobskoe oil field signed by the chief engineer of GTPP
Value of data applied (for ex ante calculation/ determinations)	Not applicable
Justification of the choice of data or description of measurement methods and procedures (to be) applied	This parameter is required to calculate emissions from APG flaring in the baseline during 2010-2012
QA/QC procedures (to be) applied	See Section D.2.
Any comment	No additional comments

<b>Data/parameter</b>	TDL
Data unit	%
Description	Losses during transmission and distribution of grid electricity in UES Urals
Time of determination/ monitoring	Annually
Source of data (to be) used	Annual reports of OJSC "Inter-regional distribution grid company of Urals" <sup>11</sup> and OJSC "TiumenErgo" <sup>12</sup> posted in the Internet
Value of data applied (for ex ante calculation/ determinations)	Not applicable
Justification of the choice of data or description of measurement methods and procedures (to be) applied	UES Urals includes the grids of Sverdlovsk, Chelyabinsk, Perm, Orenburg, Tiumen, Kirov and Kurgan Regions, Udmurtia Republic, and Bashkiria Republic. The largest energy systems of UES Urals are Perm, Sverdlovsk, Chelyabinsk and Tiumen grids. Their share in total installed capacity of UES Urals is 74% and total capacity is 31,268.5 MW. Losses during transmission and distribution of grid electricity are calculated as the arithmetic average of losses in these four largest regional grids.
QA/QC procedures (to be) applied	See Section D.2.
Any comment	No additional comments

<b>Data/parameter</b>	$\rho_{CO_2}$
Data unit	kg/m <sup>3</sup>

<sup>11</sup> <http://www.mrsk-ural.ru/ru/460>

<sup>12</sup> <http://www.te.ru/>



Description	CO <sub>2</sub> density under standard conditions
Time of <u>determination/ monitoring</u>	Fixed ex-ante parameter
Source of data (to be) used	State standard GOST 8050-85 «Gaseous and liquid carbon dioxide» <sup>13</sup> .
Value of data applied (for ex ante calculation/ determinations)	1.839
Justification of the choice of data or description of measurement methods and procedures (to be) applied	This parameter is taken from the current national standard because it is not measured by the enterprise
QA/QC procedures (to be) applied	Not applicable for fixed ex-ante parameters
Any comment	No additional comments

<b>Data/parameter</b>	FE <sub>F</sub>
Data unit	nondimensional
Description	Efficiency of APG flaring
Time of <u>determination/ monitoring</u>	Fixed ex-ante parameter
Source of data (to be) used	IPCC Guidelines for National GHG Inventories (2006) Vol.2, chapter 4, p. 4. 54 <sup>14</sup>
Value of data applied (for ex ante calculation/ determinations)	0.98
Justification of the choice of data or description of measurement methods and procedures (to be) applied	This parameter is applied according to IPCC Guidelines as the most conservative
QA/QC procedures (to be) applied	Not applicable for fixed ex-ante parameters
Any comment	No additional comments

<b>Data/parameter</b>	GWP <sub>CH<sub>4</sub></sub>
Data unit	t CO <sub>2</sub> /t CH <sub>4</sub>
Description	Global warming potential of methane
Time of <u>determination/ monitoring</u>	Fixed ex-ante parameter
Source of data (to be) used	Climate Change (1995) The Science of Climate Change: Summary for Policymakers and Technical Summary of the Working Group I Report, p.22
Value of data applied (for ex ante calculation/ determinations)	21
Justification of the choice of data or description of measurement methods and	UNFCCC website <sup>15</sup>

<sup>13</sup> <http://www.docload.ru/Basesdoc/10/10469/index.htm>

<sup>14</sup> [http://www.ipcc-nggip.iges.or.jp/public/2006gl/pdf/2\\_Volume2/V2\\_4\\_Ch4\\_Fugitive\\_Emissions.pdf](http://www.ipcc-nggip.iges.or.jp/public/2006gl/pdf/2_Volume2/V2_4_Ch4_Fugitive_Emissions.pdf)



procedures (to be) applied	
QA/QC procedures (to be) applied	Not applicable for fixed ex-ante parameters
Any comment	No additional comments

<b>Data/parameter</b>	$\rho_{CH_4}$
Data unit	kg/m <sup>3</sup>
Description	Density of methane under standard conditions
Time of <u>determination/ monitoring</u>	Fixed ex-ante parameter
Source of data (to be) used	National standard GOST 30319.1-96 «Physical properties of natural gas, its components and products of its processing» <sup>16</sup>
Value of data applied (for ex ante calculation/ determinations)	0.667
Justification of the choice of data or description of measurement methods and procedures (to be) applied	This parameter is taken from the current national standard because it is not measured by the enterprise
QA/QC procedures (to be) applied	Not applicable for fixed ex-ante parameters
Any comment	No additional comments

<b>Data/parameter</b>	EF <sub>grid_Ural</sub>
Data unit	tCO <sub>2</sub> /MWh
Description	CO <sub>2</sub> emission factor for electricity supplied to UES Urals grid
Time of <u>determination/ monitoring</u>	Fixed ex-ante parameter
Source of data (to be) used	“Development of the electricity carbon emission factors for Russia” <sup>17</sup> , 2010, Lahmeyer International by order of European Bank for Reconstruction and Development. It was approved by Accredited Independent Entity TUV Sud.
Value of data applied (for ex ante calculation/ determinations)	2008 - 0,576 (in the absence of value calculated for year 2008 the value for 2009 has been taken) 2009 – 0,576 2010 – 0,582 2011 – 0,609 2012 – 0,649 2013 – 0,581 2014 – 0,564 2015 – 0,588 2016 – 0,573 2017 – 0,575 2018 – 0,571

<sup>15</sup> [http://unfccc.int/ghg\\_data/items/3825.php](http://unfccc.int/ghg_data/items/3825.php)

<sup>16</sup> <http://www.docload.ru/Basesdoc/9/9224/index.htm>

<sup>17</sup> [http://www.ebrd.com/downloads/sector/eccc/Baseline\\_Study\\_Russia.pdf](http://www.ebrd.com/downloads/sector/eccc/Baseline_Study_Russia.pdf)



	2019 – 0,568 2020 – 0,568.
Justification of the choice of data or description of measurement methods and procedures (to be) applied	The Study includes a thorough data review and analysis under a long term perspective. This was executed in order to reliably simulate the development of Russia’s electricity systems. Official data has been made available with support of the Ministry of Economic Development of Russia, which also acts as National Focal Point for Joint Implementation.
QA/QC procedures (to be) applied	Not applicable for fixed ex-ante parameters
Any comment	No additional comments

**B.2. Description of how the anthropogenic emissions of greenhouse gases by sources are reduced below those that would have occurred in the absence of the JI project:**

For demonstration that the project provides reductions in emissions by sources that are additional to any that would otherwise occur, the following step-wise approach was used:

**Step 1. Identification and description of the approach applied**

Additionality of the proposed project shall be proved in accordance with requirement 2(a) of Annex 1 of JI Guidance on criteria for baseline setting and monitoring, version 02.

Justification of additionality is done in several steps, after consideration of economic attractiveness of alternative technologies implemented elsewhere in blast furnace process and at sintering plants.

*Selection of plausible alternatives for the baseline scenario and their legislative implications*

**Step 2. Application of the approach chosen**

Section B.1 provides analysis of possible scenarios of use of APG and procurement of electricity at Priobskoe oil field. As a result of the analysis two following alternatives were left:

Alternative 1

Flaring of APG at Priobskoe oil field and consumption of electricity purchased from UES Urals grid.

Alternative 2 (proposed project scenario without registration as JI).

As it is shown in Section B.1 Alternative 1 is selected as a baseline scenario. In the Step 3 below it will be shown that Alternative 2 is not financially attractive.

**Implementation of APG utilization project at Priobskoe oil field as described in section A.2.**

**Step 3. Provision of additionality proofs**

*Investment analysis*

The goal of this analysis is to prove that the proposed project scenario is not economically attractive for OJSC “Oil Company Rosneft”.

Table B.2-1. Parameters applied in investment analysis<sup>18</sup>

No	Parameter	Value
----	-----------	-------

<sup>18</sup> These parameters shall be confirmed by Project Determinator and reported to JI Supervisory Committee upon request after obtaining approvals from the project participants.

Discount rate, %	20.0
Timeframe of economic evaluation, years	20

Table B.2-1. Parameters applied in investment analysis (continued)

<b>Indicators, without VAT</b>	<b>2010</b>	<b>2011</b>	<b>2012</b>	<b>2013</b>	<b>2014</b>	<b>2015</b>	<b>2016</b>	<b>2017</b>	<b>2018</b>
APG sale price, RUB per thousand m <sup>3</sup>	624	718	825	885	948	1 017	1 090	1 164	1 242
Stable gas condensate sale price	6 075	5 636	5 427	5 794	6 152	6 516	6 881	7 285	7 788
Electricity purchase price, RUB/KWh	1.70	1.92	2.08	2.23	2.39	2.56	2.74	2.92	3.12
Costs of gross APG extraction, RUB per thousand m <sup>3</sup>	345	366,0	390	418	447	478	512	547	583
Cost of production and sale of gas condensate, RUB/t	410	436	464	497	532	569	609	650	694

<b>2019</b>	<b>2020</b>	<b>2021</b>	<b>2022</b>	<b>2023</b>	<b>2024</b>	<b>2025</b>	<b>2026</b>	<b>2027</b>	<b>2028</b>	<b>2029</b>
1 310	1 372	1 437	1 492	1 549	1 607	1 666	1 723	1 777	1 832	1 889
8 189	8 445	8 767	9 091	9 412	9 746	10 029	10 248	10 488	10 758	11 030
3.29	3.44	3.58	3.71	3.85	3.99	4.13	4.26	4.39	4.53	4.67
615	644	669	694	720	747	772	797	821	847	873
732	767	796	826	857	889	919	948	977	1 008	1 039

Total capital costs of the proposed project were 27,550 million RUB of which previously invested funds were 15,554.7 million RUB (at the time of the elaboration of the analysis by LLC “RN-Uganskneftegas” in the beginning of 2010). Therefore the presented analysis characterizes the whole economic efficiency of the Gas programme of Priobskoe oil field during timeframe of its economic evaluation. It shall be taken into account that capital costs of 27,550 million RUB are to be born solely by Rosneft company for its own infrastructure of APG utilization at Priobskoe oilfield, and all inputs and outputs of the considered economic study do not relate to the earlier mentioned Joint Implementation project “Processing of associated petroleum gas at Yuzhno-Balyksky gas processing plant” of SIBUR company. Table B.2-2. summarizes the results of investment analysis.<sup>19</sup>

Table B.2-2. Results of investment analysis for the project scenario

<b>Indicators for the period 2010-2029</b>	<b>Net present value (NPV)</b>	<b>Internal rate of return (IRR)</b>	<b>Discounted payback period (DPP)</b>	<b>Capital costs (without VAT)</b>

<sup>19</sup> Investment analysis was carried out by Rosneft economists using standard economic valuation models.



<i>Unit</i>	<i>Million RUB</i>	<i>%</i>	<i>years</i>	<i>Million RUB</i>
Feasibility of the implementation of APG utilization project including previously invested funds	-8 674.5	13,1%	Sunk costs	27,550

The lowest acceptable project IRR in Rosneft (internal benchmark) in 2010 was 20%. Based on Table B.2-2 it is clear that besides IRR all other indicators (NPV, DPP) of the proposed project were also below the generally acceptable levels.

**Conclusion: the investment analysis shows that the proposed project was not economically attractive for the management of OJSC “Oil Company “Rosneft” at the time when investment decision was made.**

#### *Sensitivity analysis*

Since the goal of the proposed project was recovery of previously flared APG, the sensitivity analysis was conducted with respect to possible variation in capital costs and electricity sales price. Table B.2-4. summarizes the results of sensitivity analysis.

Table B.2-4. Results of sensitivity analysis

<b>Percentage change</b>	<b>Net present value NPV</b>	<b>Internal rate of return (IRR)</b>	<b>Discounted payback period (DPP)</b>
	<i>Million RUB</i>	<i>%</i>	<i>years</i>
Change in capital costs			
-10%	-7 616.7	13.7	sunk costs
+10%	- 9 732.3	12.5	sunk costs
Change in electricity purchase price			
-10%	- 11 478.1	10.6	sunk costs
+10%	- 5 870.8	15.4	sunk costs

Financially attractive project shall have positive NPV under all considered scenarios<sup>20</sup>.

**Sensitivity analysis confirmed that this project was not financially viable because of negative NPV under all considered scenarios.**

#### ***Identification of significant barriers to project implementation***

This analysis considers economic situation which existed in 2006, when the decision about project implementation at Priobskoe oil field was made.

#### ***Barrier No.1 Associated petroleum gas price regulation and price disproportions***

The net cost of APG recovery is initially higher than that of natural gas because of high capital costs of construction of infrastructure for collection, transportation and processing of APG, and because of technological complexity of APG recovery. The abovementioned obstacles make APG utilization

<sup>20</sup> Guidelines for analysis of effectiveness of investment projects. Approved by Russian Ministry of Economic Development and Trade, Ministry of Finance, and State Committee on Construction, Architecture and Residential Policy on 21.06.1999, Decision # BK 477.



activities unprofitable for oil producing companies especially at small and remote oil fields with limited APG resources.

In the 1990s after the collapse of Soviet economic system and transition to market economy the problem of APG utilization shifted from macroeconomic level of “national economic efficiency” to microeconomic level of company’s cost-effectiveness. The production capacities of Siberian gas-processing plants became underused after oil production fell down at many large but exhausted oil fields, and because oil companies did not have the system of APG recovery and transportation from the distant oil fields. Some gas-processing facilities were temporarily abandoned.

At the same time low oil prices and economic instability provided disincentives to utilize APG at newly explored oil-fields. In 1995 Siberian state-owned gas processing plants merged into SIBUR company, which had the authority and responsibility to address gas processing problems. SIBUR proved itself unprofitable, because the government, in its attempt to save a petrochemical complex from collapse, regulated the disbursing prices for BFLH (the main product of gas processing) and liberated the prices for associated gas the raw material purchased by gas processing plants, which made this price following the inflation.

Later the State reintroduced regulation of APG and dry gas prices (Decree # 239 of 07.03.1995).<sup>21</sup> Between 2002 and 2008 during price regulation period the price for APG remained practically stable. The disproportion of prices is illustrated by the following fact: the maximum state regulated price for APG was \$17 per 1,000 m<sup>3</sup> (depending on content of the heavier hydrocarbons it varied from 73 to 442 RUB per 1,000 m<sup>3</sup>), while the price of the two main products of its processing (natural gas and propane-butane) was over \$85<sup>22</sup>.

At the same time according to the estimates of oil companies, the transportation of APG from remote fields to gas-processing stations led to increase of APG price to \$30 per 1,000 m<sup>3</sup>, making its processing unprofitable, because the net cost of natural gas production was only \$4-7 per 1,000 m<sup>3</sup> (Gazprom estimate). This is why oil companies preferred in the past and still prefer to flare APG.

The Government abolished the severance tax with the goal to stimulate subsoil users to utilize APG in 2001. At the same time the penalties for the gas flaring were quite low (50 RUB per ton of methane within the maximum permissible emission limit and 250 RUB per ton of methane for emissions within the temporary approved emission limit,<sup>23</sup> and the sale price of APG for gas-processing plants was regulated by state. In such circumstances oil companies had more incentives to flare APG than to process it. Between 2000 and 2005 the amount of annually flared APG increased from 6.6 billion m<sup>3</sup> to 14.9 billion m<sup>3</sup> according to official data. It means more than two-times increase, while oil production in Russia increased only by 1.5 times during the same period.<sup>24</sup>

**This barrier was a constraint for Rosneft when it had to make a decision about APG utilization project implementation at Priobskoe oil field.**

#### *Analysis of common practice*

---

<sup>21</sup> [tarif.kurganobl.ru/assets/files/laws/Postanovlenie\\_N239\\_07.03.1995.pdf](http://tarif.kurganobl.ru/assets/files/laws/Postanovlenie_N239_07.03.1995.pdf)

<sup>22</sup> [http://www.expert.ru/printissues/expert/2007/30/sankcii\\_protiv\\_gazovyh\\_fakelov/](http://www.expert.ru/printissues/expert/2007/30/sankcii_protiv_gazovyh_fakelov/)

<sup>23</sup> The Decree of the Government of the Russian Federation # 410 of 01.07.05 “On amendments to Annex 1 to the Decree of the Russian Government # 344 of 12.06.03”.

<sup>24</sup> [http://expert.ru/expert/2007/30/sankcii\\_protiv\\_gazovyh\\_fakelov/](http://expert.ru/expert/2007/30/sankcii_protiv_gazovyh_fakelov/)



Addressing the Federal Assembly in April of 2007 Russian President Vladimir Putin mentioned that flaring of large volumes of APG was a big problem of Russian fuel and energy sector. According to official estimates 57.9 billion m<sup>3</sup> of APG was annually recovered 24.4% of which was flared in Russia<sup>25</sup>.

After the President's declaration Russian ministries and agencies put forward several initiatives in this area. To prevent flaring they proposed several mandatory measures for the companies. Despite the political will to solve this problem, one may unlikely expect that the target to reach 95% APG utilization set by the government will be fulfilled in the near future, and this was even pointed out by the Russian ministers.<sup>26</sup> Development of the complex and countrywide policy in order to reach this ambitious goal has not been yet finalized, while technical design cycle and construction of APG collection and utilization projects takes between 3 and 5 years.<sup>27</sup>

APG utilization in 1990s was difficult because of gas processing industry crisis. Russian oil companies did not have enough funds in the conditions of unprecedentedly low oil prices. Rapid growth of oil prices in early 2000s and governmental efforts boosted oil production volumes. In 2006 Russia became the unofficial world leader in the volumes of flared APG because of numerous barriers to APG utilization (which the Government addresses today).

According to the Federal Ministry of Natural Resources, 65.4 billion m<sup>3</sup> of APG was extracted in Russia in 2010, of which 15.7 billion m<sup>3</sup> was flared. The largest APG flaring companies were OJSC "Oil Company "Rosneft" (6.1 billion m<sup>3</sup>); OJSC TNK-BP Holding, OJSC Lukoil and OJSC Gazpromneft (each about 2 billion m<sup>3</sup>). Together these four companies accounted for 76% of APG flaring in Russia.

The rate of APG flaring in Russia in 2010 was 24%. According to official statistics this rate stayed at 24% between 2006 and 2010, while the absolute volume of flaring increased following the expansion of APG extraction from 57.9 billion m<sup>3</sup> in 2006 to 65.4 billion m<sup>3</sup> in 2010.

Mr. Grigory Vygon, Director of Economic and Finance Department of Russian Ministry of Natural Resources said that pollution fee could provide an incentive for oil and gas companies to utilize APG if this fee was comparable to the amount of capital investments in APG utilization projects. Specific investment costs in such projects required to reach the announced target of APG utilization may reach 4,800 RUB per 1,000 m<sup>3</sup> of gas. According to Russian Ministry of Natural Resources total income raised from collection of oil companies' pollution charges for APG flaring is about 340 million RUB, which is equivalent to 20 RUB per 1,000 m<sup>3</sup> of flared gas.<sup>28</sup>

The largest oil companies are planning to invest about 300 billion RUB in APG utilization projects in the period 2010-2015, which is equivalent to 50 billion RUB per year or about 6% of their total investments in oil extraction. Given these projected spending the estimated rate of APG flaring in Russia will decrease to 18% in 2012 and to 5% in 2014.

However the projects implemented jointly under Article 6 of the Kyoto Protocol should be excluded from the analysis of common practice.

As of May 2011 about 42.5 million tons of CO<sub>2</sub>-eq. of emission reductions could have been generated by all JI projects submitted project documentation in Russia. Of these potential project the share of officially approved projects is only 18.2 million tons of CO<sub>2</sub>-eq. The largest of these JI projects are APG utilization projects in oil sector.<sup>29</sup> Flaring of 1,000 m<sup>3</sup> of APG typically releases about 2.5 tons of CO<sub>2</sub>-eq. Thus only the officially approved projects will prevent flaring of 7.28 billion m<sup>3</sup> of APG during the

---

<sup>25</sup> <http://www.lawtek.ru/news/tek/40363.html>

<sup>26</sup> <http://www.lawtek.ru/news/tek/40363.html>

<sup>27</sup> [http://www.erta-consult.ru/index.php?option=com\\_content&task=view&id=289&Itemid=62](http://www.erta-consult.ru/index.php?option=com_content&task=view&id=289&Itemid=62)

<sup>28</sup> [http://www.mnr.gov.ru/news/detail.php?ID=118430&sphrase\\_id=4930](http://www.mnr.gov.ru/news/detail.php?ID=118430&sphrase_id=4930)

<sup>29</sup> <http://www.sberbank.ru/moscow/ru/legal/cfinans/>

years of 2008-2012. This is one-half of APG which was actually flared in 2010 using the official statistics of Russian Ministry of Natural Resources. All submitted JI projects could prevent flaring of 17 billion m<sup>3</sup> of APG.

**Therefore analysis of existing situation shows that APG utilization projects could not be considered a common practice in Russia without additional financing via JI mechanism. Together with results of investment analysis and barrier analysis this constitutes a proof of additionality of APG utilization project implemented by OJSC “Oil Company “Rosneft” at Priobskoe oil field.**

**B.3. Description of how the definition of the project boundary is applied to the project:**

The following installations are included within the project boundaries:

- Flaring installations at the existing oil collection and preparation facilities of Priobskoe oil field;
- APG transportation and treatment infrastructure to be constructed during project implementation: compressor stations of low separation stages, CS-1 and CS-2, GTI;
- Priobskaya GTPP;
- Power plants of UES Urals.

Table B 3.1: Emission sources under the baseline and project conditions

	Source	Gas	Included/not included	Comments and explanations
Baseline	APG flaring	CO <sub>2</sub>	Included	This is the main source of emissions under the baseline
		CH <sub>4</sub>	Included	Methane is released to the atmosphere due to incomplete combustion of APG. Methane emissions are estimated using the default coefficients of IPCC Guidelines (2006)
		N <sub>2</sub> O	Not included	Emissions are negligible
	Consumption of electricity generated by UES Urals power plants	CO <sub>2</sub>	Included	This is the main source of emissions under the baseline. We assume that the net supply of electricity of Priobskaya GTPP under the project scenario is equal to the supply of electricity generated by UES Urals power plants taking in account the transportation and distribution losses.
		CH <sub>4</sub>	Not included	Emissions are negligible
		N <sub>2</sub> O	Not included	Emissions are negligible



Project	Emissions from utilization of APG or other fuel within the project boundaries	CO <sub>2</sub>	Included	<p>GTPP: Combustion of APG which was treated at GTI. Reserve fuel for GTPP is natural gas. The emissions from combustion of reserve fuel are also included.</p> <p>CS-1: combustion of APG as a fuel is not included because the volume of APG supplied to YB GPP is monitored at the end of the APG pipeline to there and APG, which is used for own needs in the project scenario would have been flared under the baseline scenario.</p> <p>CS-2: APG from CS-2 is supplied to GTI or CS-1. Thus APG which is used for own needs in the project scenario would have been flared under the baseline scenario.</p>
		CH <sub>4</sub>	Not included	Emissions are negligible
		N <sub>2</sub> O	Not included	Emissions are negligible
	Consumption of electricity within the project boundaries	CO <sub>2</sub>	Included	<p>Electricity consumption by CS-1, CS-2, GTI and the compressor stations of APG of final separation stages is the source of emissions under the project scenario. Year 2009 was not included into consideration as project cannot generate ERUs in this period (see section A.2.).</p> <p>The conservative assumption was made that electricity consumed within the project boundaries was produced by UES Urals power plants taking in account the transmission and distribution losses.</p>
		CH <sub>4</sub>	Not included	Emissions are negligible
		N <sub>2</sub> O	Not included	Emissions are negligible





Fax: +7 495 984 59 52

e-mail: [konstantin.myachin@carbontradefinance.com](mailto:konstantin.myachin@carbontradefinance.com)

“CTF Consulting”, LLC is not a project participant.

**SECTION C. Duration of the project / crediting period**

**C.1. Starting date of the project:**

November 2007 (commissioning of CS-1)

**C.2. Expected operational lifetime of the project:**

The expected project operational lifetime is 22 years or 254 months, beginning in 2007 and ending in 2029.

**C.3. Length of the crediting period:**

5 years 0 months / 60 months from 01.01.2008 to 31.12.2012.

Could be extended up to the maximum period between 01.01.2013 and 31.12.2020 (eight years extra) if the extension of crediting period for this project is approved by the Russian Federation. The extended length of the crediting period will be 8 years 0 months / 96 months.

**SECTION D. Monitoring plan****D.1. Description of monitoring plan chosen:**

According to Appendix B to Decision 9/CMP.1 (refer to the Report of the Conference of the Parties serving as the meeting of the Parties to the Kyoto Protocol on its first session, held at Montreal from 28 November to 10 December 2005) and JI Guidance on criteria for baseline setting and monitoring, Version 02 project monitoring plan comprises the following steps:

**Step 1. Identification and description of the approach chosen regarding monitoring**

PDD developer applies a JI specific approach of GHG emissions monitoring under the project and the baseline, according to Paragraph 9(a) of JI Guidance on criteria for baseline setting and monitoring, Version 02.

The project is aimed at recovery of APG which would have been flared otherwise. In the absence of the proposed project the power demand of the facilities located in Priobskoe oil field would have been covered by power supplied from UES Urals grid.

Project CO<sub>2</sub> emissions were calculated as follows:

1. CO<sub>2</sub> emissions from electricity consumption by CS-1, CS-2, GTI, the compressor stations for APG of low pressure (final) separation stages at OTTW-7, PWDU of cluster 285, OTTW-8, PWDU of cluster 201 were calculated on the basis of their electricity consumption (in the years 2008 and 2010-2011 as applicable), the coefficient of losses for grid electricity, and CO<sub>2</sub> emission factor for UES Urals grid. The coefficient of losses during transmission and distribution of grid electricity of UES Urals was estimated as the arithmetic mean of those coefficients for the largest energy systems of UES Urals: Perm, Sverdlovsk, Chelyabinsk and Tiumen grids. Their share in total installed capacity of UES Urals is 74%.
2. CO<sub>2</sub> emissions of GTPP were calculated using the data on consumption of treated APG, APG chemical composition, consumption of natural gas as a reserve fuel, the lower calorific value and CO<sub>2</sub> emission factor of natural gas.
3. Finally, total CO<sub>2</sub> emissions from the installations of Priobskoe oil field were calculated for the project scenario.

The equations used in this approach are provided in Section D.1.1.2.

The following principles were applied during baseline CO<sub>2</sub> emission calculations:

For year 2008:

6. Based on measured volume and chemical composition of APG supplied to YB GPP of OJSC "Sibur" the weight of carbon was calculated. It was then converted to equivalent amount of CO<sub>2</sub> to be released to the atmosphere during flaring of this gas;
7. Incomplete combustion of APG in flares means that certain fraction of APG is released to the atmosphere without oxidation. IPCC Guidelines (2006) estimated the efficiency of flaring as 98%. The remaining 2% of APG is emitted directly to the atmosphere which causes the atmospheric emission of



methane.<sup>30</sup> Using the volume of APG supplied to YB GPP, its chemical composition and global warming potential of methane the equivalent emissions of CO<sub>2</sub> from incomplete combustion of APG were estimated.

For the period 2009-2012:

8. Based on measured volume and chemical composition of APG, which is treated in GTI and supplied to GTPP as a fuel the weight of carbon was calculated. It was then converted to the equivalent amount of CO<sub>2</sub> to be released in the atmosphere during flaring of this gas;
9. Similar to described in item (7) using the volume of APG supplied to GTPP, chemical composition of this gas and global warming potential of methane, the equivalent emissions of CO<sub>2</sub> from incomplete combustion of APG were estimated.
1. Using the data on actual net output of electricity from Priobskaya GTPP and CO<sub>2</sub> emission factor for electricity produced by power plants of UES Urals as well as the percentage of losses during transmission and distribution of grid electricity the equivalent CO<sub>2</sub> emissions during electricity production by UES Urals power plants in the baseline were estimated.

The equations used in this approach are provided in Section D.1.1.4.

## Step 2. Application of the approach chosen

According to Guidelines for users of the JI PDD form, Version 04 the application of monitoring plan needs to explicitly and clearly distinguish:

- a. Data and parameters that are not monitored throughout the crediting period, but are determined only once (and thus remain fixed throughout the crediting period), and that are available already at the stage of determination;
- b. Data and parameters that are not monitored throughout the crediting period, but are determined only once (and thus remain fixed throughout the crediting period), but that are not yet available at the stage of determination; and
- c. Data and parameters that are monitored throughout the crediting period.

In the project context the application is following:

***Data and parameters that are not monitored throughout the crediting period, but are determined only once (and thus remain fixed throughout the crediting period), and that are available already at the stage of determination***

Table D.1-1. Data and parameters that are fixed during the crediting period, and are available at the stage of determination

---

<sup>30</sup> National greenhouse gas inventory guidelines, IPCC, 2006. Vol 2, Section 4, p. 4.45.



№	Parameter and measurement unit	Notation	Value	Data source
1.	CO <sub>2</sub> density under standard conditions (P = 101.3 kPa, T = 293.16° K (+20° C), kg/m <sup>3</sup> )	$\rho_{CO_2}$	1.839	State standard GOCT 8050-85 «Gaseous and liquid carbon dioxide» <sup>31</sup> .
2.	Efficiency of combustion of treated APG at GTPP, dimensionless	$FE_{GTPP}$	1.0	The 100% oxidation of carbon by combustion of treated APG in GTPP turbines was assumed. The same assumption was used during calculation of emission factors for combustion of various fuels in IPCC Guidelines for National GHG Inventories (2006) Vol.2, Chapter 1, paragraph 1.4.2.1.
3.	Lower calorific value of natural gas, MJ/m <sup>3</sup>	$NCV_{NG}$	33.5	This value was reported in the monthly reports “Indicators of Quality of Natural Gas”. Chemical composition of natural gas remains fairly stable, and the lower calorific value has not changed since September of 2010
4.	CO <sub>2</sub> emission factor of natural gas, t CO <sub>2</sub> /GJ	$\%C_{energy\ coal}$	0.0561	IPCC Guidelines for National GHG Inventories (2006) Vol. 2, Chapter 2, p. 2.16.
5.	APG flaring efficiency, dimensionless	$FE_F$	0.98	IPCC Guidelines for National GHG Inventories (2006) Vol. 2, Chapter 4, p. 4.54.
6.	Density of methane under standard conditions (P = 101.3 kPa, T = 293.16° K (+20° C), kg/m <sup>3</sup> )	$\rho_{CH_4}$	0.667	National standard GOST 30319.1-96 «Physical properties of natural gas, its components and products of its processing» <sup>32</sup> .
7.	Global warming potential of methane, t CO <sub>2</sub> /t CH <sub>4</sub> , dimensionless	$GWP_{CH_4}$	21	Climate Change 1995, The Science of Climate Change: Summary for Policymakers and Technical Summary of the Working Group I Report, p.22

<sup>31</sup> <http://www.docload.ru/Basesdoc/10/10469/index.htm>

<sup>32</sup> <http://www.docload.ru/Basesdoc/9/9224/index.htm>



*Data and parameters that are not monitored throughout the crediting period, but are determined only once (and thus remain fixed throughout the crediting period), but that are not yet available at the stage of determination*

Table D.1-2. Data and parameters that remain fixed throughout the crediting period, and that are not available at the stage of determination

No	Parameter and measurement unit	Notation	Value	Data source
1.	CO <sub>2</sub> emission factor for electricity supplied to UES Urals grid, t CO <sub>2</sub> /MWh	EF <sub>grid_Ural</sub>	2008 - 0,576 (in the absence of value calculated for year 2008 the value for 2009 has been taken) 2009 – 0,576 2010 – 0,582 2011 – 0,609 2012 – 0,649 2013 – 0,581 2014 – 0,564 2015 – 0,588 2016 – 0,573 2017 – 0,575 2018 – 0,571 2019 – 0,568 2020 – 0,568	“Development of the electricity carbon emission factors for Russia” <sup>33</sup> , 2010, Lahmeyer International by order of European Bank for Reconstruction and Development. It was approved by Accredited Independent Entity TUV Sud.

<sup>33</sup> [http://www.ebrd.com/downloads/sector/eccc/Baseline\\_Study\\_Russia.pdf](http://www.ebrd.com/downloads/sector/eccc/Baseline_Study_Russia.pdf)

**Data and parameters that are monitored throughout the crediting period**

These parameters are described in sections D.1.1.1. and D.1.1.3. below.

Figure D.1.1: Location of monitoring points. Notations correspond to Tables D.1.1.1., D.1.1.3.

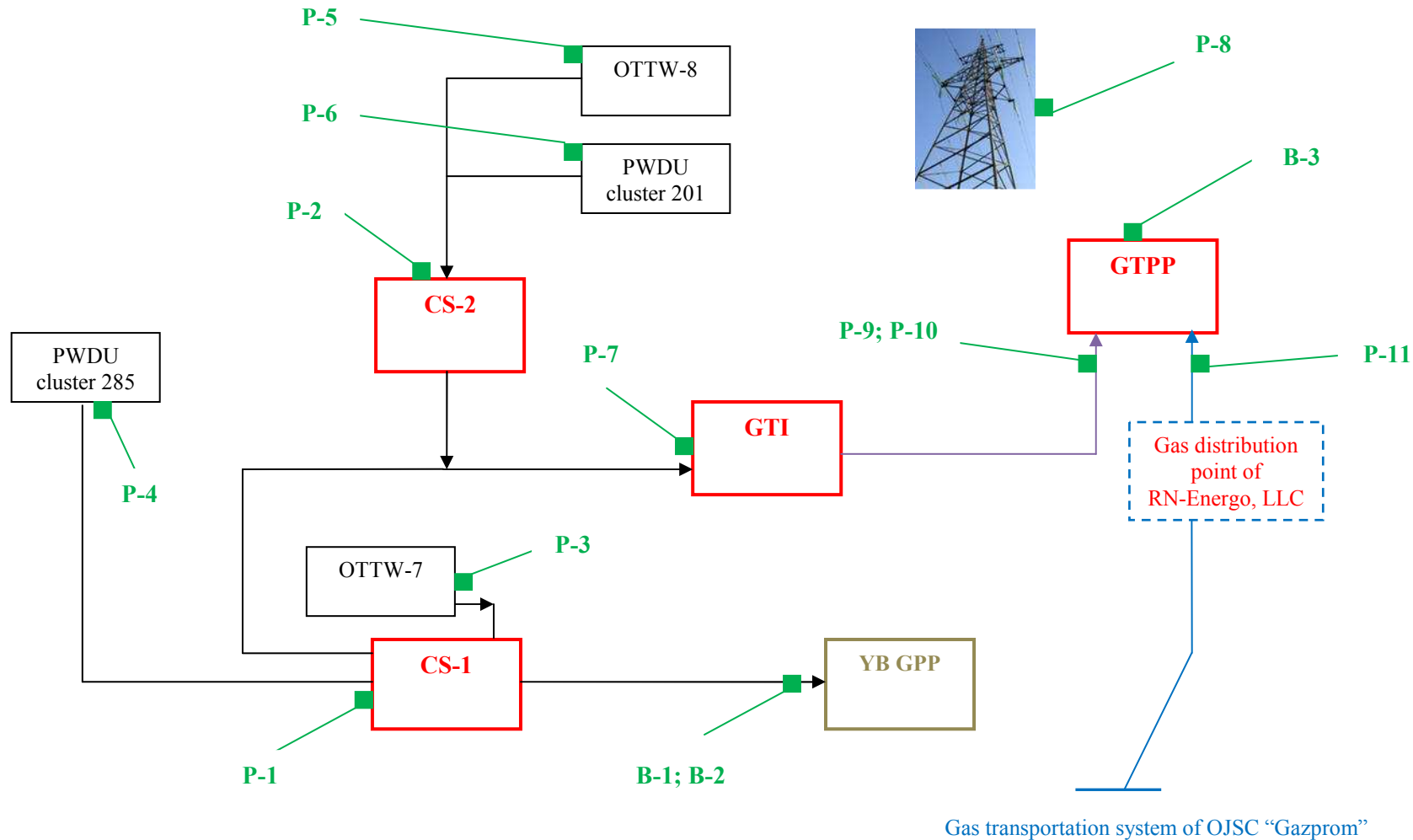

**D.1.1. Option 1 – Monitoring of the emissions in the project scenario and the baseline scenario:****D.1.1.1. Data to be collected in order to monitor emissions from the project, and how these data will be archived:**

ID number (Please use numbers to ease cross-referencing to D.2.)	Data variable	Source of data	Data unit	Measured (m), calculated (c), estimated (e)	Recording frequency	Proportion of data to be monitored	How will the data be archived? (electronic/ paper)	Comment
<b><i>Consumption of electricity by the compressor stations and GTI</i></b>								
P-1	<b>EC<sub>CS-1</sub></b> Electricity consumption by CS-1	Energy department	MWh	m	Monthly	All	Electronic/ paper	Monthly values entered in “Electricity Consumption Report”
P-2	<b>EC<sub>CS-2</sub></b> Electricity consumption by CS-2	Energy department	MWh	m	Monthly	All	Electronic/ paper	Monthly values entered in “Electricity Consumption Report”
P-3	<b>EC<sub>OTTW-7</sub></b> Electricity consumption by the compressor station of APG of final separation stages at OTTW- 7	Energy department	MWh	m	Monthly	All	Electronic/ paper	Monthly values entered in “Electricity Consumption Report”
P-4	<b>EC<sub>PWDU c.285</sub></b> Electricity consumption by the compressor station of APG	Energy department	MWh	m	Monthly	All	Electronic/ paper	Monthly values entered in “Electricity Consumption Report”



	of final separation stages at PWDU of cluster 285							
P-5	<b>EC<sub>OTTW-8</sub></b> Electricity consumption by the compressor station of APG of final separation stages at OTTW-8	Energy department	MWh	m	Monthly	All	Electronic/ paper	Monthly values entered in "Electricity Consumption Report"
P-6	<b>EC<sub>PWDU c.201</sub></b> Electricity consumption by the compressor station of APG of final separation stages at PWDU of cluster 201	Energy department	MWh	m	Monthly	All	Electronic/ paper	Monthly values entered in "Electricity Consumption Report"
P-7	<b>EC<sub>GTI</sub></b> Electricity consumption for own needs of GTI	Energy department	MWh	m	Monthly	All	Electronic/ paper	Monthly values entered in "Electricity Consumption Report"
P-8	<b>TDL</b> Process losses of UES Urals grid electricity during transmission and distribution	OJSC Inter-regional distribution grid company of Urals and OJSC TiumenErgo	%	c	Annually	All	Electronic	Annual reports of OJSC Inter-regional distribution grid company of Urals <sup>34</sup> and

<sup>34</sup> <http://www.mrsk-ural.ru/ru/460>



								OJSC TiumenEnerg <sup>35</sup> posted in the Internet (latest available)
<b>Consumption of gases by GTPP</b>								
P-9	FC <sub>APG treated</sub> Consumption of treated APG at GTPP	Department of treatment of oil and gas	1000 m <sup>3</sup>	m	Monthly	All	Electronic/ paper	Current values are entered in APG acceptance and delivery certificate
P-10	Y <sub>i APG treated</sub> Volumetric fraction of component in the treated APG	Department of treatment of oil and gas	Vol %	m	Daily	All	Electronic/ paper	Monthly averages are entered in Excel spreadsheet "Chemical composition of APG"
P-11	FC <sub>NG</sub> Consumption of natural gas by GTPP	Department of fuel and energy resources	1000 m <sup>3</sup>	m	Monthly	All	Electronic/ paper	Values are entered in the Natural Gas Acceptance Certificate of GTPP

**D.1.1.2. Description of formulae used to estimate project emissions (for each gas, source, etc.; emissions in units of CO<sub>2</sub> equivalent):**

Project CO<sub>2</sub> emissions from consumption of electricity by CS-1, CS-2, GTI, compressor stations of APG of final separation stages at OTTW-7, PWDU of cluster 285, OTTW-8, and PWDU of cluster 201

$$PE_{EC\_CSs+GTI} = (EC_{CS-1} + EC_{CS-2} + EC_{GTI} + EC_{OTTW-7} + EC_{PWDU\ c.285} + EC_{OTTW-8} + EC_{PWDU\ c.201}) * EF_{grid} * (1 + TDL) \quad (D.1.1.2.-1)$$

<sup>35</sup> <http://www.te.ru/>



Where:

$PE_{EC_{CS+GTI}}$  – project CO<sub>2</sub> emissions from consumption of electricity by CS-1, CS-2, GTI, compressor stations of APG of final separation stages at OTTW-7, PWDU of cluster 285, OTTW-8, and PWDU of cluster 201, tCO<sub>2</sub>-eq.

$EC_{CS-1}$  – consumption of electricity by CS-1, MWh

$EC_{CS-2}$  – consumption of electricity by CS-2, MWh

$EC_{GTI}$  – consumption of electricity by GTI, MWh

$EC_{OTTW-7}$  – consumption of electricity by the compressor station of APG of final separation stages at OTTW-7, MWh

$EC_{PWDU_{c.285}}$  – consumption of electricity by the compressor station of APG of final separation stages at PWDU of cluster 285, MWh

$EC_{OTTW-8}$  – consumption of electricity by the compressor station of APG of final separation stages at OTTW-8, MWh

$EC_{PWDU_{c.201}}$  – consumption of electricity by the compressor station of APG of final separation stages at PWDU of cluster 201, MWh

$EF_{grid}$  – CO<sub>2</sub> emission factor of UES Urals grid

TDL – process losses during transmission and distribution of grid electricity in UES Urals, %

#### Process loss during transmission and distribution of grid electricity in UES Urals

$$TDL = (TDL_{Perm\ PES} + TDL_{Sverdlovsk\ PES} + TDL_{Chelyabinsk\ PES} + TDL_{Tyumen\ PES}) / 4 \quad (D.1.1.2.-2)$$

Where:

TDL – losses during transmission and distribution of grid electricity in UES Urals, %

$TDL_{Perm\ PES}$  – losses during transmission and distribution of grid electricity in UES of Perm region, %

$TDL_{Sverdlovsk\ PES}$  – losses during transmission and distribution of grid electricity in UES of Sverdlovsk region, %

$TDL_{Chelyabinsk\ PES}$  – losses during transmission and distribution of grid electricity in UES of Chelyabinsk region, %

$TDL_{Tyumen\ PES}$  – losses during transmission and distribution of grid electricity in UES of Tiumen region, %

#### Project CO<sub>2</sub> emissions from operations of GTPP

$$PE_{GTPP} = PE_{APG\ treated} + PE_{NG} \quad (D.1.1.2.-3)$$

Where:

$PE_{GTPP}$  – project CO<sub>2</sub> emissions from operations of GTPP, tCO<sub>2</sub>-eq.

$PE_{APG\ treated}$  – project CO<sub>2</sub> emissions from combustion at GTPP of the APG treated by GTI, tCO<sub>2</sub>-eq.

$PE_{NG}$  – project CO<sub>2</sub> emissions from combustion of NG at GTPP, tCO<sub>2</sub>-eq.

**Project CO<sub>2</sub> emissions from combustion of APG at GTPP**

$$PE_{APG \text{ treated}} = FC_{APG \text{ treated}} * EF_{CO_2, APG \text{ treated}, GTPP} \quad (D.1.1.2.-4)$$

Where:

$PE_{APG \text{ treated}}$  – project CO<sub>2</sub> emissions from combustion at GTPP of the APG treated by GTI, tCO<sub>2</sub>-eq.

$FC_{APG \text{ treated}}$  – consumption of treated APG by GTPP, 1000 m<sup>3</sup>

$EF_{CO_2, APG \text{ treated}, GTPP}$  - CO<sub>2</sub> emission factor for combustion of treated APG by GTPP, tCO<sub>2</sub>/1000 m<sup>3</sup>

**CO<sub>2</sub> emission factor for combustion of APG by GTPP**

$$EF_{CO_2, APG \text{ treated}, GTPP} = \sum_i y_i APG \text{ treated} * N_c * \rho_{CO_2} * FE_{GTPP} \quad (D.1.1.2.-5)$$

Where:

$EF_{CO_2, APG \text{ treated}, GTPP}$  - CO<sub>2</sub> emission factor for combustion of treated APG by GTPP, tCO<sub>2</sub>/1000 m<sup>3</sup>

$y_i APG \text{ treated}$  – volumetric fraction of component in the treated APG, vol %

$N_c$  – molar content of carbon in treated component i of APG, dimensionless (see Annex 2 for additional information).

$\rho_{CO_2}$  – density of CO<sub>2</sub>, kg/m<sup>3</sup>

$FE_{GTPP}$  – efficiency of combustion of treated APG at GTPP, dimensionless

**Project CO<sub>2</sub> emissions from combustion of NG at GTPP**

$$PE_{NG} = FC_{NG} * NCV_{NG} * EF_{NG} \quad (D.1.1.2.-6)$$

Where:

$PE_{NG}$  – project CO<sub>2</sub> emissions from combustion of NG at GTPP, tCO<sub>2</sub>-eq.

$FC_{NG}$  – consumption of NG at GTPP, 1000 m<sup>3</sup>

$NCV_{NG}$  – lower calorific value of NG, MJ/m<sup>3</sup>

$EF_{NG}$  - NG emission factor, tCO<sub>2</sub>/GJ

**TOTAL PROJECT EMISSIONS OF CO<sub>2</sub>**



$$PE = PE_{EC\_CSs+GTI} + PE_{GTPP}$$

(D.1.1.2.-7)

Where:

PE - total project emissions of CO<sub>2</sub> from the installations of Priobskoe oil field, tCO<sub>2</sub>-eq.

PE<sub>EC\_CSs</sub> – project CO<sub>2</sub> emissions from consumption of electricity by CS-1, CS-2, GTI, compressor stations of low separation stages at OTTW-7, PWDU of cluster 285, OTTW-8, and PWDU of cluster 201, t CO<sub>2</sub>-eq.

PE<sub>GTPP</sub> – project CO<sub>2</sub> emissions from operations of GTPP, t CO<sub>2</sub>-eq.

D.1.1.3. Relevant data necessary for determining the <u>baseline</u> of anthropogenic emissions of greenhouse gases by sources within the project boundary, and how such data will be collected and archived:								
ID number <i>(Please use numbers to ease cross-referencing to D.2.)</i>	Data variable	Source of data	Data unit	Measured (m), calculated (c), estimated (e)	Recording frequency	Proportion of data to be monitored	How will the data be archived? (electronic/ paper)	Comment
B-1	FC <sub>APG, YBGPP</sub> Volume of APG, supplied to YB GPP in 2008	Department of oil and gas treatment	million m <sup>3</sup>	m	Monthly	All	Electronic/paper	The values are entered in high- pressure gas acceptance certificate
B-2	Y <sub>i, APG</sub> Volumetric fraction of component in the APG	Chemical analytical lab of OTTW-7	Vol %	m	Daily	All	Electronic/paper	The values are averaged by components of the gas mixture and entered in the technical passport of supplied gas each month



P-9	<b>FC</b> APG treated Consumption of treated APG by GTPP	Gas Recovery and Transportation Department No. 4	1000 m <sup>3</sup>	m	Monthly	All	Electronic/paper	The values are entered in APG delivery- acceptance certificate
P-10	<b>Y<sub>i</sub></b> APG treated Volumetric fraction of component in the treated APG	Gas Recovery and Transportation Department No. 4	Vol %	m	Daily	All	Electronic/paper	Monthly average values are entered in Excel spreadsheet “Component composition of APG”
B-3	<b>EG</b> GTPP Net output of electricity from Priobskaya GTPP	GTPP	kWh	m	Monthly	All	Electronic/paper	Priobskaya GTPP Electricity Production Report
P-7	<b>TDL</b> Process loss of UES Urals grid electricity during transmission and distribution	OJSC Inter- regional distribution grid company of Urals and OJSC TiumenEnerg	%	c	Annually	All	Electronic	Annual reports of OJSC Inter- regional distribution grid company of Urals <sup>36</sup> and OJSC TiumenEnerg <sup>37</sup> posted in the Internet

<sup>36</sup> <http://www.mrsk-ural.ru/ru/460>

<sup>37</sup> <http://www.te.ru/>

**D.1.1.4. Description of formulae used to estimate baseline emissions (for each gas, source etc.; emissions in units of CO<sub>2</sub> equivalent):****EMISSIONS FROM APG FLARING UNDER BASILINE SCENARIO IN 2008**

$$BE_{F, 2008} = BE_{CO_2, F, 2008} + BE_{CH_4, F, 2008} \quad (D.1.1.4.-1)$$

Where:

$BE_{F, 2008}$  – total emissions from flaring of APG under the baseline in year 2008 tCO<sub>2</sub>-eq.

$BE_{CO_2, F, 2008}$  – CO<sub>2</sub> emissions from flaring of APG under the baseline in year 2008, tCO<sub>2</sub>-eq.

$BE_{CH_4, F, 2008}$  – CH<sub>4</sub> emissions from flaring of APG under the baseline in year 2008, tCO<sub>2</sub>-eq.

**CO<sub>2</sub> emissions from flaring of APG under the baseline in year 2008**

$$BE_{CO_2, F, 2008} = FC_{APG, YBGPP} * EF_{CO_2, F} \quad (D.1.1.4.-2)$$

Where:

$BE_{CO_2, F, 2008}$  – CO<sub>2</sub> emissions from flaring of APG under the baseline in year 2008, tCO<sub>2</sub>-eq.

$FC_{APG, YBGPP}$  – the volume of APG supplied to YB GPP in 2008, 1000 m<sup>3</sup>

$EF_{CO_2, F}$  – CO<sub>2</sub> emission factor for APG flaring, t CO<sub>2</sub>/1000 m<sup>3</sup>

**CO<sub>2</sub> emission factor for APG flaring (see more details in Annex 2)**

$$EF_{CO_2, F} = \sum_i y_{i, APG} * N_{c, APG} * \rho_{CO_2} * FE_F \quad (D.1.1.4.-3)$$

Where:

$EF_{CO_2, F}$  – CO<sub>2</sub> emission factor for APG flaring, t CO<sub>2</sub>/1000 m<sup>3</sup>

$y_{i, APG}$  – volumetric fraction of component in the APG, vol %

$N_{c, APG}$  – molar content of carbon in component i of APG, dimensionless

$\rho_{CO_2}$  – density of CO<sub>2</sub>, kg/m<sup>3</sup>

$FE_F$  – efficiency of combustion of APG in flares, dimensionless

**CH<sub>4</sub> emissions from flaring of APG under the baseline in year 2008**

$$BE_{CH_4, F 2008} = FC_{APG, YBGPP} * EF_{CH_4, F}$$

**(D.1.1.4.-4)**

Where:

$BE_{CH_4, F 2008}$  – CH<sub>4</sub> emissions from flaring of APG under the baseline in year 2008, tCO<sub>2</sub>-eq.

$FC_{APG, YBGPP}$  – the volume of APG supplied to YB GPP in 2008, 1000 m<sup>3</sup>

$EF_{CH_4, F}$  – emission factor for methane released during APG flaring, converted to CO<sub>2</sub>-eq., tCO<sub>2</sub>/1000 m<sup>3</sup>

**Emission factor for methane released during APG flaring, converted to CO<sub>2</sub>-eq.**

$$EF_{CH_4, F} = y_{CH_4 APG} * \rho_{CH_4} * (1 - FE_F) * GWP_{CH_4}$$

**(D.1.1.4.-5)**

Where:

$EF_{CH_4, F}$  – emission factor for methane released during APG flaring, converted to CO<sub>2</sub>-eq., tCO<sub>2</sub>/1000 m<sup>3</sup>

$y_{CH_4}$  – volumetric fraction of component in the APG, vol. %

$\rho_{CH_4 APG}$  – density of methane under standard conditions, kg/m<sup>3</sup>

$FE_F$  – efficiency of combustion of APG in flares, dimensionless

$GWP_{CH_4}$  – global warming potential of methane, t CO<sub>2</sub>/t CH<sub>4</sub>

**EMISSIONS FROM APG FLARING UNDER THE BASILINE IN 2010-2012**

$$BE_{F 2010-2012} = BE_{CO_2, F 2010-2012} + BE_{CH_4, F 2010-2012}$$

**(D.1.1.4.-6)**

Where:

$BE_{F 2010-2012}$  – total emissions from flaring of APG under the baseline in 2010-2012, tCO<sub>2</sub>-eq.

$BE_{CO_2, F 2010-2012}$  – CO<sub>2</sub> emissions from flaring of APG under the baseline in 2010-2012, tCO<sub>2</sub>-eq.

$BE_{CH_4, F 2010-2012}$  – CH<sub>4</sub> emissions from flaring of APG under the baseline in 2010-2012, tCO<sub>2</sub>-eq.

**CO<sub>2</sub> emissions from flaring of APG under the baseline in 2010-2012**

$$BE_{CO_2, F 2010-2012} = FC_{APG \text{ treated}} * EF_{CO_2, APG \text{ treated } F} \quad (D.1.1.4.-7)$$

Where:

$BE_{CO_2, F 2010-2012}$  – CO<sub>2</sub> emissions from flaring of APG under the baseline in 2010-2012, tCO<sub>2</sub>-eq.

$FC_{APG \text{ treated}}$  – the volume of treated APG by GTPP, 1000 m<sup>3</sup>

$EF_{CO_2, APG \text{ treated } F}$  – CO<sub>2</sub> emission factor for flaring of treated APG, tCO<sub>2</sub>/1000 m<sup>3</sup>

**CO<sub>2</sub> emission factor for flaring of treated APG**

$$EF_{CO_2, APG \text{ treated } F} = \sum_i y_{i, APG \text{ treated}} * N_{c APG \text{ treated}} * \rho_{CO_2} * FE_F \quad (D.1.1.4.-8)$$

Where:

$EF_{CO_2, APG \text{ treated } F}$  – CO<sub>2</sub> emission factor for flaring of treated APG, tCO<sub>2</sub>/1000 m<sup>3</sup>

$y_{i, APG \text{ treated}}$  – volumetric fraction of component i in the treated APG, vol %

$N_{c APG \text{ treated}}$  – molar content of carbon in component i in treated APG, dimensionless

$\rho_{CO_2}$  – density of CO<sub>2</sub>, kg/m<sup>3</sup>

$FE_F$  – efficiency of combustion of APG in flares, dimensionless

**CH<sub>4</sub> emissions from flaring of treated APG**

$$BE_{CH_4, F 2010-2012} = FC_{APG \text{ treated}} * EF_{CH_4, APG \text{ treated } F} \quad (D.1.1.4.-9)$$

Where:

$BE_{CH_4, F 2010-2012}$  – CH<sub>4</sub> emissions from flaring of treated APG under the baseline in 2010-2012, tCO<sub>2</sub>-eq.

$FC_{APG \text{ treated}}$  – consumption of treated APG by GTPP, 1000 m<sup>3</sup>

$EF_{CH_4, APG \text{ treated } F}$  – emission factor for methane released during flaring of treated APG, converted to CO<sub>2</sub>-eq., tCO<sub>2</sub>/1000 m<sup>3</sup>

**Emission factor for methane released during flaring of treated APG, converted to CO<sub>2</sub>-eq.**

$$EF_{CH_4, APG \text{ treated F}} = y_{CH_4 APG \text{ treated}} * \rho_{CH_4} * (1 - FE_F) * GWP_{CH_4} \quad (D.1.1.4.-10)$$

Where:

$EF_{CH_4, APG \text{ treated F}}$  – emission factor for methane released during flaring of treated APG, converted to CO<sub>2</sub>-eq., tCO<sub>2</sub>/1000 m<sup>3</sup>

$y_{CH_4 APG \text{ treated}}$  – the fraction of methane in treated APG by volume, vol. %

$\rho_{CH_4 APG}$  – density of methane under standard conditions, kg/m<sup>3</sup>

$FE_F$  – efficiency of combustion of APG in flares, dimensionless

$GWP_{CH_4}$  – global warming potential of methane, t CO<sub>2</sub>/t CH<sub>4</sub>

**EMISSIONS FROM CONSUMPTION OF GRID ELECTRICITY UNDER THE BASELINE**

$$BE_{EC} = EG_{GTPP} * EF_{grid} * (1 + TDL) \quad (D.1.1.4.-11)$$

Where:

$BE_{EC}$  – emissions from consumption of grid electricity under the baseline, tCO<sub>2</sub>-eq.

$EG_{GTPP}$  – net output of electricity produced by GTPP, MWh

$EF_{grid}$  – CO<sub>2</sub> emission factor of the Urals grid ( $EF_{grid} = 0.541$  t CO<sub>2</sub>/MWh)

TDL – losses during transmission and distribution of grid electricity in UES Urals, %

**TOTAL CO<sub>2</sub> EMISSIONS UNDER THE BASELINE**

$$BE = BE_{F 2008} + BE_{F 2010-2012} + BE_{EC} \quad (D.1.1.4.-12)$$

Where:

BE – total CO<sub>2</sub> emissions under the baseline, tCO<sub>2</sub>-eq.

$BE_{F 2008}$  – emissions from APG flaring under the baseline in 2008, tCO<sub>2</sub>-eq.



BE<sub>F 2010-2012</sub> – emissions from APG flaring under the baseline in 2010-2012, tCO<sub>2</sub>-eq.

BE<sub>EC</sub> – emissions from consumption of grid electricity under the baseline, tCO<sub>2</sub>-eq.

**D. 1.2. Option 2 – Direct monitoring of emission reductions from the project (values should be consistent with those in section E.):**

Not applicable. This section is left blank on purpose.

<b>D.1.2.1. Data to be collected in order to monitor emission reductions from the project, and how these data will be archived:</b>								
ID number <i>(Please use numbers to ease cross-referencing to D.2.)</i>	Data variable	Source of data	Data unit	Measured (m), calculated (c), estimated (e)	Recording frequency	Proportion of data to be monitored	How will the data be archived? (electronic/ paper)	Comment

Not applicable.

**D.1.2.2. Description of formulae used to calculate emission reductions from the project (for each gas, source etc.; emissions/emission reductions in units of CO<sub>2</sub> equivalent):**

Not applicable

**D.1.3. Treatment of leakage in the monitoring plan:**

Fugitive emissions associated with the proposed project arise from the following activities:

1. Transportation of APG and NG and transmission of electricity;
2. Operations of the equipment which is decommissioned during project implementation and moved beyond the project boundaries.

Methane is released during extraction, processing, condensation, transportation, regasification and distribution of natural gas and APG, which are used as fuels by GTPP. There are also fugitive emission associated with extraction of fossil fuels in the absence of the proposed project. The supply of natural gas, coal and oil fuel under the baseline scenario is greater than the supply of APG and natural gas under the project scenario. Consequently the baseline scenario generates



more fugitive emissions than the project scenario, and actually achieved emission reductions would be even greater than our estimates. Therefore excluding of fugitive emissions in our estimates is a conservative assumption.

<b>D.1.3.1. If applicable, please describe the data and information that will be collected in order to monitor leakage effects of the project:</b>								
ID number <i>(Please use numbers to ease cross-referencing to D.2.)</i>	Data variable	Source of data	Data unit	Measured (m), calculated (c), estimated (e)	Recording frequency	Proportion of data to be monitored	How will the data be archived? (electronic/ paper)	Comment

Not applicable

**D.1.3.2. Description of formulae used to estimate leakage (for each gas, source etc.; emissions in units of CO<sub>2</sub> equivalent):**

Not applicable

**D.1.4. Description of formulae used to estimate emission reductions for the project (for each gas, source etc.; emissions/emission reductions in units of CO<sub>2</sub> equivalent):**

The following equation shall be used to calculate emission reductions:

$$ER_y = BE_y - PE_y \tag{D.1.4.-1}$$

Where:

ER<sub>y</sub> – Emission reduction in the period y, tCO<sub>2</sub>-eq

BE<sub>y</sub> – Baseline emissions in the period y, tCO<sub>2</sub>-eq

PE<sub>y</sub> – Project emissions in the period y, tCO<sub>2</sub>-eq



**D.1.5. Where applicable, in accordance with procedures as required by the host Party, information on the collection and archiving of information on the environmental impacts of the project:**

Russian environmental law requires periodic revisions of the current pollution permits taking into account newly commissioned emission sources. These sources at Priobskoe oil field include CS-1, CS-2, GTI, and GTPP.

Federal Law FZ-7 of 10.01.2002 “On Environmental Protection” requires that the heads and chief engineers of the companies-polluters possess the necessary qualifications in environmental protection and environmental safety.

The Department of environmental protection at RN-Uganskneftegas LLC. is responsible for enforcement of environmental standards and regulations, obtaining of pollution permits and waste disposal permits from the authorized governmental agencies.

APG quality is monitored by periodic sampling of APG received by GTPP. Chemical analytical laboratory of GTI of Gas Recovery and Transportation Department No. 4 (GRTD-4) conducts chemical analyses of these samples observing the requirements specified in Technical Standards GOST 23781, GOST 22667, GOST 22387.2, and GOST 22387.2. The reports are filed in hard copy format and contain the results of chemical analysis of fuel composition and its physical and chemical properties (humidity, calorific value, Vobbe number), along with sampling place and date.

The revised pollution permit shall contain the schedule of environmental control checks.

All reports on utilized fuels and environmental impact data are sent directly to the head office of RN-Uganskneftegas LLC.

**D.2. Quality control (QC) and quality assurance (QA) procedures undertaken for data monitored:**

Data (Indicate table and ID number)	Uncertainty level of data (high/medium/low)	Explain QA/QC procedures planned for these data, or why such procedures are not necessary.
Table D.1.1.1. P-1 EC <sub>CS-1</sub>	Low	35/6kV step-down substation No. 1708 with electric capacity 2x10MVA supplies electricity to CS-1. Electricity is distributed through a 30-cell K63 switchgear fed by two cables from the substation No. 1708. Instrument rating of electric meters is 0.5-2.0 There is no commercial accounting.
P-2 EC <sub>CS-2</sub>	Low	35/6kV step-down “Booster” substation with electric capacity 2x16 MVA supplies electricity to CS-2. Electricity at CS-2 is distributed through a 6 kV switchgear which is connected to the existing 35/6kV step-down “Booster” substation. The consumers of 0.4 kV electricity receive power supply from the four two-transformer internal substations 2KTPP-1600M/6/0.4 with oil transformers. Instrument rating of electric meters is 0.5-2.0 There is no commercial accounting.



P-3 EC <sub>OTTW-7</sub> P-4 EC <sub>PWDU c.285</sub> P-5 EC <sub>OTTW-8</sub> P-6 EC <sub>PWDU c.201</sub>	Low	OTTW-7: "Takat" compressors are powered from 35/6kV step-down substation No. 1707 via 6kV "Technologicheskaya" switchgear. PWDU of cluster 285: "Takat" compressors are powered from 35/6kV step-down substation No. 3785 via 6kV "BPS with PWDU" switchgear. OTTW-8 is powered from 35/6kV step-down substation No. 5712. PWDU of cluster 201 is powered from 35/6kV step-down substation No. 5701. Instrument rating of electric meters is 0.5-2.0 There is no commercial accounting.
P-7 EC <sub>GTI</sub>	Low	GTI is powered from 35/6kV step-down transformer No. 1708 (feeders 1708-07 and 1708-08) via the two 6/0.4 kV two-transformer substations 6/0.4 kV; the first substation feeds the main production installations; the second substation feeds auxiliary equipment. Instrument rating of electric meters is 0.5-2.0 There is no commercial accounting.
P-8 TDL	Low	Annual reports of "Inter-regional distribution grid company of Urals" <sup>38</sup> и OJSC "TiumenEnergо" <sup>39</sup> , posted in the Internet.
P-9 FC <sub>APG treated</sub>	Low	Consumption of treated APG by GTPP is metered by ultrasonic meter FLOWSIC 600 manufactured by «SICK MAIHAK GmbH». This meter is located in GTI of GRTD-4. Its run-time measurement accuracy is +/- 0.3 %.
P-10 y <sub>i</sub> APG treated	Low	Chemical composition of treated APG is measured by MicroSAM chromatograph manufactured by Siemens AG, located in GTI of GRTD-4. Its measurement error is +/- 0.2 %.
P-11 FC <sub>NG</sub>	Low	Consumption of natural gas by GTPP is metered by ultrasonic meter FLOWSIC 600 manufactured by «SICK MAIHAK GmbH». This meter is located in GTI of GRTD-4. Its run-time measurement accuracy is +/- 0.3 %.
B-1 FC <sub>APG, YBGPP</sub>	Low	The volume of APG supplied to YB GPP is metered by ultrasonic meter FLOWSIC 600 manufactured by «SICK MAIHAK GmbH». This meter is located in the high-pressure gas inlet of YB GPP.
B-2 y <sub>i</sub> APG	Low	Chemical composition of APG is measured by Chrystal 2000M chromatograph, installed in the chemical analytical laboratory of OTTW-7. Its measurement error is +/- 15 %.
B-3 EG <sub>GTPP</sub>	Low	A 110 kV 27-cell switchgear supplies electricity to the consumers through the block transformers TRDN-63000/110-UHL1. The eight 110 kV power transmission lines connect this switchgear with the substations: Rosliakovskaya substation – 4 lines; Monastyrskaya substation – 2 lines; and Zenkovo substation – 2 lines. Commercial meters are installed in the following cells of the substations: Rosliakovskaya substation 4 – cell 19; Monastyrskaya substation 1 – cell 6; Monastyrskaya substation 2 – cell 4; and Rosliakovskaya substation 3 – cell 17. These cells are equipped with multipurpose electronic meters Alpha A1802RAL-P4GB-DW-4. Their instrument rating is 0.2S/0.5.

Metrological service of Netfeyugansk branch of OJSC RN-Inform provides technical maintenance, repairs, calibration and testing services of the metering devises. Chief metrological engineer of OJSC RN-Energо approves the testing and calibration schedule.

<sup>38</sup> <http://www.mrsk-ural.ru/ru/460>

<sup>39</sup> <http://www.te.ru/>

**D.3. Please describe the operational and management structure that the project operator will apply in implementing the monitoring plan:**

The management structure of project monitoring shall be adapted to the existing system of data collection and accounting of RN-Uganskneftegas LLC. The following table specifies the responsible officials and their obligations:

No№	Company	Position and department	Responsibilities	Objectives
1.	RN-Uganskneftegas LLC	Chief engineer	Management of monitoring process	Approval of monitoring reports
2.	RN-Uganskneftegas LLC	Department of fuel and energy resources	Preparation of monthly reports on the consumption of APG by GTPP	Data processing, storage and quarterly reporting to CTF Consulting, LLC
3.	RN-Uganskneftegas LLC	Energy department	Preparation of monthly reports on electricity consumption by industrial facilities of Priobskoe oil field	Data processing, storage and quarterly reporting to CTF Consulting, LLC
4.	Khanty-Mansiisky Autonomous District Branch of RN-Energo	Gas Recovery and Transportation Department No. 4	Preparation of monthly reports on the consumption of treated APG by GTPP	Data processing, storage and quarterly reporting to CTF Consulting, LLC
5.	RN-Uganskneftegas LLC	Department of oil and gas treatment	Storage of monthly reports of APG supply to YB GPP in 2008	Data processing, storage and quarterly reporting to CTF Consulting, LLC
6.	Khanty-Mansiisky Autonomous District Branch of RN-Energo	GTPP	Preparation of reports on electricity supply to the consumers	Data storage
7.	RN-Uganskneftegas LLC	Department of oil treatment. Chemical analytical lab of OTTW-7	Preparation of data on chemical composition of APG supplied to YB GPP	Data processing, storage and quarterly reporting to CTF Consulting, LLC
8.	RN-Uganskneftegas LLC	Gas Recovery and Transportation Department No. 4	Preparation of data on chemical composition of treated APG	Data processing, storage and quarterly reporting to CTF Consulting, LLC



**Description of monitoring system**

The experts of “CTF Consulting”, LLC will calculate GHG emission reductions on quarterly basis. They will use the equations specified in Section D of this PDD, and the data reported by RN-Uganskneftegas LLC.

Estimated emission reductions shall be reported to the head office of OJSC “Oil Company “Rosneft”. The person responsible for the Project (Chief Engineer of RN-Uganskneftegas LLC.) will monitor data reporting process, including data verification, storage and systematization.

**D.4. Name of person(s)/entity(ies) establishing the monitoring plan:**

The developer of monitoring plan:

“CTF Consulting”, LLC

Moscow, Baltchug street 7, Business-center “Baltchug Plaza”, office 629;

Contact person: Konstantin Myachin, Carbon Project Manager

Ph: +7 495 984 59 51

Fax: +7 495 984 59 52

e-mail: [konstantin.myachin@carbontradefinance.com](mailto:konstantin.myachin@carbontradefinance.com)

“CTF Consulting”, LLC is not a project participant.

**SECTION E. Estimation of greenhouse gas emission reductions****E.1. Estimated project emissions:*****Project emissions in 2008 - 2010***

Project emissions during 2008-2010 have been calculated using the equations of Section D.1.1.2 and actual monthly and annual data reported by RN-Uganskneftegas LLC. Electricity consumption by CS-2 in 2010 equals to zero because this station was not yet in operation.

Process losses during transmission and distribution of grid electricity of UES Urals were calculated with Equation D.1.1.2.-2. The data were taken from the annual reports of OJSC Inter-regional distribution grid company of Urals (2008)<sup>40</sup> and OJSC TiumenEnergO (2009, with data for preliminary three years).<sup>41</sup> Actual process losses for the regional grids were:

- PermEnergO: 10.56%;
- SverdlovEnergO: 5.96%;
- ChelyabEnergO: 7.36 %;
- TiumenEnergO: 2.64%.

The mean electricity losses for UES Urals in 2008 (TDL) calculated as an average for these four largest energy systems was 6.63%.

The same figures for 2009 were taken from the annual reports<sup>42,43</sup>

- PermEnergO: 11.87%;
- SverdlovEnergO: 6.68%;
- ChelyabEnergO: 8.51 %;
- TiumenEnergO: 2.48%.

The mean electricity losses for UES Urals in 2009 (TDL) calculated as an average for these four largest energy systems was 7.385%. The same estimate was used as the proxy for year 2010, because statistics was not yet available.

***Project emissions in 2011-2012***

The projected net output of electricity generated by Priobskaya GTPP was used to calculate project emissions in 2011-2012:

2011 – 1 981 205 MWh

2012 – 2 283 908 MWh.

As soon as the expected time of commissioning of GTU#4,5,6 – August 2011 than based on actual average output of the electricity from first four GTUs (GTU 1,2,3 and 7) on the period November 2010 to March 2011 (period of stable load after probation period of GTU #7 commissioned in June 2010) the annualization was done and three new built GTUs were added with assumption of their electricity generation in September – December 2011. Hereby the value for 2011 was made. The value for 2012

---

<sup>40</sup> <http://www.mrsk-ural.ru/ru/460>

<sup>41</sup> <http://www.te.ru/>

<sup>42</sup> <http://www.mrsk-ural.ru/content/files/IR%202009%20AR/ru2009ARweb.pdf>

<sup>43</sup> <http://www.reports.te.ru/>

was taken based on Rosneft's plans (Reference on the output of electricity by Priobskaya GTPP, December 2010).

Project emissions from consumption of electricity for own needs of CS-1, the compressors of APG of low pressure at OTTW-7, PWDU of cluster 285, OTTW-8, PWDU of cluster 201 and GTI for year 2011 were calculated with equations D.1.1.2.-1 and D.1.1.2.-2, using actual electricity consumption data for the first quarter of 2011 in annualized terms, and for compressors of APG of low pressure at OTTW-8, PWDU of cluster 201 - for the half a year (expected time of commissioning – August 2011). Electricity consumption of CS-2 in 2012 was assumed to be equal to 38,000 MWh per year (according to the project design document “Compressor Station CS-2 of Priobskoe oil field, Vol.1. Book 4. Electricity supply, p.6”), and in 2011 – conservatively - a half of this value, which is 19,000 MWh (expected time of commissioning – August 2011). Electricity consumption for own needs of the compressors and GTI in 2012 was assumed to be the same as in 2011 with annualization (where it is needed).

#### Project emissions from operations of GTPP in 2011-2012

The consumption of treated APG by GTPP is calculated in the basis of unit fuel consumption data specified in the technical passports of the turbines.

$$FC_{APG\ treated} = 351 * EG_{GTPP} * 0,0293076 / NCV_{APG\ treated} \quad (E.1.-1)$$

Where:

$FC_{APG\ treated}$  – consumption of treated APG by GTPP, 1000 m<sup>3</sup>

351 – fuel consumption by GTPP turbines in grams of coal eq. per kWh

$EG_{GTPP\ 2011}$  – net output of electricity from Priobskaya GTPP, MWh (we assumed that GTPP uses treated APG as primary fuel between April and December of 2011 and all months in 2012)

0,0293076 – tons.coal equivalent to GJ conversion factor

$NCV_{APG\ treated}$  – calorific value of treated APG, MJ/m<sup>3</sup>

It was assumed that the losses during transmission and distribution of grid electricity in 2011-2012 will be the same as in 2009 (7.385%).

CO<sub>2</sub> emission factor for combustion of treated APG at GTPP in 2011-2012 ( $EF_{CO_2, APG\ treated, GTPP}$ ) is assumed to be the same as in April-May 2011 – 2.282 t CO<sub>2</sub>/1000 m<sup>3</sup>

Actual consumption of natural gas by GTPP in the first quarter of 2011 was applied. The plant started to use APG again in April of 2011, and it was assumed that the GTPP will not use natural gas ever since then.

Table E.1-1: Project CO<sub>2</sub> emissions in 2008-2012, tCO<sub>2eq</sub>/year

Parameter	2008	2009	2010	2011	2012
Project emissions of CO <sub>2</sub> from CS-1, CS-2, GTI, the compressor stations of APG of final separation stages at OTTW-7, PWDU of cluster 285, OTTW-8, PWDU of cluster 201	9 033	-	18 800	39 645	63 420
Project emissions of CO <sub>2</sub> from electricity consumption by GTI	-	-	618	4 707	5 016
Project emissions of CO <sub>2</sub> from combustion of APG by GTPP	-	-	133 177	953 467	1 372 285
Project emissions of CO <sub>2</sub> from combustion of NG by GTPP	-	6 123	458 228	224 105	0
<b>Total:</b>	<b>9 033</b>	<b>6 123</b>	<b>610 824</b>	<b>1 221 924</b>	<b>1 440 721</b>

**Project emissions in 2013-2020**

Are assumed to be the same as in 2012.

**E.2. Estimated leakage:**

Not applicable

**E.3. The sum of E.1. and E.2.:**

Table E.3-1: the sum of E.1. and E.2., t CO<sub>2</sub>/y

Parameter	2008	2009	2010	2011	2012	2013-2020
Project emissions of CO <sub>2</sub> from CS-1, CS-2, GTI, the compressor stations of APG of final separation stages at OTTW-7, PWDU of cluster 285, OTTW-8, PWDU of cluster 201	9 033	-	18 800	39 645	63 420	63 420
Project emissions of CO <sub>2</sub> from electricity consumption by GTI	-	-	618	4 707	5 016	5 016
Project emissions of CO <sub>2</sub> from combustion of APG by GTPP	-	-	133 177	953 467	1 372 285	1 372 285
Project emissions of CO <sub>2</sub> from combustion of NG by GTPP	-	6 123	458 228	224 105	0	0
<b>Total:</b>	<b>9 033</b>	<b>6 123</b>	<b>610 824</b>	<b>1 221 924</b>	<b>1 440 721</b>	<b>1 440 721</b>

**E.4. Estimated baseline emissions:****Baseline emissions in 2008 – 2010**

Baseline emissions for 2008 and 2010 were estimated using the equations specified in Section D.1.1.4 and actual monthly and annual data reported by RN-Uganskneftegas LLC.

**Baseline emissions in 2011 – 2012**

Baseline emissions in 2011-2012 were estimated on the basis of projected net output of electricity from Priobskaya GTPP. In baseline this amount of power would be covered by the grid power. (Table E.1.1.).

The volume of treated APG supplied to GTPP, which would otherwise have been flared, was calculated on the basis of unit fuel consumption by the turbines (similar to equation E.1.-1).

Emission factor for CO<sub>2</sub> released during flaring of treated APG (EF<sub>CO<sub>2</sub>, APG treated F</sub>) was assumed to be equal to the the value in April-May 2011: 2.236 t CO<sub>2</sub>/1000 m<sup>3</sup>

Emission factor for methane (converted to CO<sub>2</sub>-eq.) released during flaring of treated APG was assumed to be equal to the the value in April-May 2011: 0.227 t CO<sub>2</sub>/1000 m<sup>3</sup>.

Table E.4-1. Baseline CO<sub>2</sub> emissions in 2008-2012, tCO<sub>2eq</sub>/year

Parameter	2008	2009	2010	2011	2012
CO <sub>2</sub> emissions from APG flaring in the baseline	994 682	-	-	-	-



CO <sub>2</sub> emissions from consumption of grid electricity in the baseline	-	-	791 014	2 324 756	3 072 858
<b>Total:</b>	<b>994 682</b>		<b>791 014</b>	<b>2 324 756</b>	<b>3 072 858</b>

Table E.4-2. Baseline CO<sub>2</sub> emissions in 2013-2020, t CO<sub>2eq</sub>/year

2013	2014	2015	2016	2017	2018	2019	2020
<b>2 906 083</b>	<b>2 864 390</b>	<b>2 923 251</b>	<b>2 886 463</b>	<b>2 891 368</b>	<b>2 881 558</b>	<b>2 874 200</b>	<b>2 874 200</b>

**E.5. Difference between E.4. and E.3. representing the emission reductions of the project:**

Equation D.1.4.-1. was used to calculate project emission reductions.

Total emission reductions in 2008-2012 are estimated to be **3 900 810 tCO<sub>2</sub>-eq.**

Annual emission reductions in 2008-2012 are estimated to be **780 162 tCO<sub>2</sub>-eq.**

Total emission reductions in 2013-2020 are estimated to be **11 575 747 tCO<sub>2</sub>-eq.**

Annual emission reductions in 2013-2020 are estimated to be **1 446 968 tCO<sub>2</sub>-eq**

**E.6. Table providing values obtained when applying formulae above:**Table E.6-1. Project and baseline emissions; emission reductions in 2008-2012, ton CO<sub>2eq</sub>/year

Year	Estimated <u>project</u> emissions (tonnes of CO <sub>2</sub> equivalent)	Estimated <u>leakage</u> (tonnes of CO <sub>2</sub> equivalent)	Estimated <u>baseline</u> emissions (tonnes of CO <sub>2</sub> equivalent)	Estimated emission reductions (tonnes of CO <sub>2</sub> equivalent)
2008	9 033	0	994 682	985 649
2009	6 123	0	-	0
2010	610 824	0	791 014	180 190
2011	1 221 924	0	2 324 756	1 102 832
2012	1 440 721	0	3 072 858	1 632 138
Total (tonnes of CO <sub>2</sub> equivalent)	3 288 625	0	7 183 311	3 900 810

The first stage of GTPP was commissioned in December of 2009. Start-up works took one month; there was no commercial generation of electricity; no emission reduction units were generated during that month.

Table E.6-2. Project and baseline emissions; emission reductions in 2013-2020, ton CO<sub>2eq</sub>/year

Year	Estimated <u>project</u> emissions (tonnes of CO <sub>2</sub> )	Estimated <u>leakage</u> (tonnes of CO <sub>2</sub> equivalent)	Estimated <u>baseline</u> emissions (tonnes of CO <sub>2</sub> )	Estimated emission reductions (tonnes of CO <sub>2</sub> )
------	---	---	--	--



	equivalent)		equivalent)	equivalent)
2013	1 440 721	0	2 906 083	1 465 363
2014	1 440 721	0	2 864 390	1 423 669
2015	1 440 721	0	2 923 251	1 482 531
2016	1 440 721	0	2 886 463	1 445 742
2017	1 440 721	0	2 891 368	1 450 647
2018	1 440 721	0	2 881 558	1 440 837
2019	1 440 721	0	2 874 200	1 433 479
2020	1 440 721	0	2 874 200	1 433 479
Total (tonnes of CO <sub>2</sub> equivalent)	11 525 765	0	23 101 512	11 575 747

The extension of project crediting period after 2012 is subject to approval of the Russian Federation as a Host party of the JI project.

## SECTION F. Environmental impacts

### F.1. Documentation on the analysis of the environmental impacts of the project, including transboundary impacts, in accordance with procedures as determined by the host Party:

Article 32 of the Federal Law on Environmental Protection # 7-FZ provides that:

“Environmental impact assessment is conducted for any projects and activities, which may directly or indirectly influence the state of the environment, irrespective of ownership type of the subjects of economic and other activities.”

Project implementation will result in reduction of negative environmental impacts because of prevention of APG flaring.

The following sources of environmental impacts have been identified at GTPP, CS-1, CS-2 and GTI:

- Short-term environmental impacts due to construction works;
- Emissions into the atmosphere (air emissions) from operations main and auxiliary equipment;
- Discharge of waste water from industrial and household consumption of drinking and industrial water;
- Production of industrial and consumption waste as the result of industrial operations;
- Noise and vibrations as the result of industrial operations.

The main sources of air emissions include GTPP turbines and compressor drives of CS-1 and CS-2. Principal pollutants include nitrous dioxide, nitrous oxide, carbon oxide, and benz(a)pyrene. Estimated pollutant concentrations do not exceed the applicable environmental standards.

Industrial and household waste waters are treated at the local waste water treatment plant and are transported offsite after treatment.

GTPP waste is stored in temporary storage and, upon accumulation of sizeable amounts of waste, is removed offsite for further treatment.

Working turbines, exhaust pipes of the turbines and boilers are the principal sources of noise. Project includes technological options of noise abatement: installation of sound-proofing covers on the turbines, attenuation treatment of the outer walls, etc.



Transboundary effects have not been estimated because project implementation and environmental protection measures confine air pollution within the regional boundaries.

All applicable requirements of environmental law have been strictly observed during construction of GTPP, CS-1, CS-2 and GTI at Priobskoe oil field. Project implementation will:

- reduce air pollution;
- prevent pollution of surface and underground waters;
- prevent on-site pollution, provided that waste storage, disposal and utilization requirements are observed;
- keep noise pollution and vibrations within maximum permissible levels;
- not create any additional health risks and environmental risks in the region.

**F.2. If environmental impacts are considered significant by the project participants or the host Party, please provide conclusions and all references to supporting documentation of an environmental impact assessment undertaken in accordance with the procedures as required by the host Party:**

The city-building Code of the Russian Federation RF No.190-FZ provides in Article 49, Paragraphs 1,4,5:

“Technical design documentation for capital construction projects is subject to state expertise. Specially designated Federal executive authority, or another agency under its jurisdiction carries out state expertise of project documentation. State expertise of project documentation establishes if the project meets the requirements of technical regulations, sanitary, epidemiological, environmental norms, the requirements in the area of protection of cultural heritage, fire safety, industrial, nuclear and radiation safety. State expertise of project documentation also establishes if the project conforms with the results of engineering survey.”

In the light of abovementioned requirement, environmental impact assessment (EIA) was conducted individually for the following installations:

- GTPP constructed in the left-bank part of Priobskoe oil field. *The list of environmental protection measures*. (Prepared by: branch of Engineering Design Center of New Generation LLC., Ekaterinburg, 2008).
- APG utilization system at Priobskoe and Prirazlomnoe oil fields of OJSC Uganskneftegas. Compressor station at Priobskoe oil field. *Environmental impact assessment. Environmental protection*. (Prepared by: OJSC GiproTiumenNeftegas, Tiumen, 2003).
- Compressor station CS-2 at Priobskoe oil field. *Environmental impact assessment. Environmental protection*. (prepared: OJSC GiproTiumenNeftegas, Tiumen, 2008).
- GTI at Priobskoe oil field. *The list of environmental protection measures*. (prepared: OJSC RusGasProject, Autonomous regional office in Tiumen, 2008).

These documents passed the State expertise prior to project implementation. The following approvals have been obtained:

- Federal Expertise Authority “Glavgosexpertiza Russia”. Decision # 205-09/GGE-5979/02 of 13.04.2009 on Priobskaya GTPP project.
- State environmental expertise. Decision # 1383 of 01.06.2004 on the project “APG utilization system at Priobskoe and Prirazlomnoe oil fields of OJSC Uganskneftegas. Compressor station at



Priobskoe oil field.” This Decision was approved by the Order of State Department of Natural Resources of Khanty-Mansiisky Autonomous District # 2883-EE of 01.06.2004.

- Khanty-Mansiisky Autonomous District Branch of Federal Expertise Authority “Glavgosexpertiza Russia”. Decision # 068-09/HME-0695/02 of 21.02.2009 on the project “Compressor station (CS-2) at Priobskoe oil field”.
- Khanty-Mansiisky Autonomous District Branch of Federal Expertise Authority “Glavgosexpertiza Russia”. Decision # 207-09/XME-0892/02 of 29.05.2009 on the project “Gas treatment installation at Priobskoe oil field”.

## SECTION G. Stakeholders’ comments

### G.1. Information on stakeholders’ comments on the project, as appropriate:

APG utilization problem is quite important for this region and has received public attention. Project implementation has been discussed in mass media including the company website.<sup>44</sup> Regional government and the President of the Russian Federation have approved this project<sup>45,46</sup>.

OJSC Rosneft regularly posts annual “Sustainable development reports” on its website. The company has set up a public feedback page on its website to be used by the stakeholders for communicating comments and proposals to the company.<sup>47</sup> Once a year, the company organizes public hearings entitled “Social and environmental activity of OJSC “Oil Company “Rosneft” to present its annual corporate report on sustainable development to the public.

---

<sup>44</sup> [http://www.rosneft.ru/news/news\\_in\\_press/06072010.html](http://www.rosneft.ru/news/news_in_press/06072010.html)

<sup>45</sup> [http://www.stroyinform.ru/archive/index.php?ELEMENT\\_ID=21258&NUMBER\\_ID=819&SECTION\\_ID=800](http://www.stroyinform.ru/archive/index.php?ELEMENT_ID=21258&NUMBER_ID=819&SECTION_ID=800)

<sup>46</sup> <http://www.energyland.info/news-show-tek-neftegaz-42342>

<sup>47</sup> <http://www.rosneft.ru/Development/reports/>

Annex 1**CONTACT INFORMATION ON PROJECT PARTICIPANTS**

Organisation:	OJSC "Oil Company "Rosneft"
Street/P.O.Box:	Sofijskaya Naberezhnaya
Building:	26/1
City:	Moscow
State/Region:	
Postal code:	117997
Country:	Russia
Phone:	+7 (495) 777-44-22
Fax:	+7 (495) 777-44-44
E-mail:	postman@rosneft.ru
URL:	<a href="http://www.rosneft.ru">www.rosneft.ru</a>
Represented by:	Rostislav Latysh
Title:	Deputy director
Salutation:	Mr.
Last name:	Latysh
Middle name:	Rostislavovich
First name:	Rostislav
Department:	Department of asset management, economics and business planning
Phone (direct):	+7 (495) 225-97-52
Fax (direct):	+7 (495) 777-47-03
Mobile:	
Personal e-mail:	r_latysh@rosneft.ru

Organisation:	Carbon Trade & Finance SICAR S.A.
Street/P.O.Box:	rue Edward Steichen
Building:	25
City/ State/Region:	
Postal code:	L-2540
Country:	Luxembourg
Phone:	+35226945752
Fax:	+35226945754
E-mail:	Info@carbontradefinance.com
URL:	<a href="http://www.carbontradefinance.com/">http://www.carbontradefinance.com/</a>
Represented by:	
Title:	Executive Director
Salutation:	Mr.
Last name:	Ramming
Middle name:	
First name:	Ingo
Department:	-
Phone (direct):	+35226945752
Fax (direct):	+35226945754
Mobile:	-
Personal e-mail:	Ingo.ramming@carbontradefinance.com

Annex 2BASELINE INFORMATION**Calculation of CO<sub>2</sub> emission factor for associated petroleum gas flare combustion**

Calculation of CO<sub>2</sub> emission factor for APG combustion in the flare device is conducted according to equation 4.4.5 proposed in Subchapter 4.2, “Fugitive emissions in oil and gas systems” of 2006 IPCC Guidelines :

$$E_{\text{CO}_2, \text{ oil prod, flaring}} = \text{GOR} * Q_{\text{oil}} * (1 - \text{CE}) * X_{\text{Flared}} * M_{\text{CO}_2} * \{y_{\text{CO}_2} + (\text{Nc}_{\text{CH}_4} * y_{\text{CH}_4} + \text{Nc}_{\text{NMVOC}} * y_{\text{NMVOC}}) (1 - X_{\text{Soot}})\} * 42.3 * 10^{-6}$$

Where:

$E_{\text{CO}_2, \text{ oil prod, flaring}}$  – direct amount of CO<sub>2</sub> emitted due to flaring at oil production facilities, gg/year;

$\text{GOR}$  – average ratio gas-to-oil referenced at 15<sup>0</sup>C and 101.325kPa, m<sup>3</sup>/m<sup>3</sup>;

$Q_{\text{oil}}$  – total annual oil production (10<sup>3</sup>m<sup>3</sup>/year);

$\text{CE}$  – gas conservation efficiency factor;

$X_{\text{Flared}}$  – fraction of waste gas (APG) that is flared rather than vented ;

$M_{\text{CO}_2}$  – molecular weight of carbon dioxide (equal to 44);

$y_{\text{CO}_2}$  – Molar or volume fraction of APG that is composed of CO<sub>2</sub>;

$\text{Nc}_{\text{CH}_4}$  – number of moles of carbon per mole of methane (equal to 1);

$y_{\text{CH}_4}$  – Mol or volume fraction of APG that is composed of CH<sub>4</sub>;

$\text{Nc}_{\text{VOC}}$  – number of moles of carbon per mole of non-methanic volatile organic compounds

$y_{\text{NMVOC}}$  – molar or volume fraction of APG that is composed of non-methanic volatile organic compounds;

$X_{\text{Soot}}$  – fraction of the non-CO<sub>2</sub> carbon in the input waste gas stream that is converted to soot or particulate matter during flaring. In the absence of any applicable data this value may be assumed to be 0 as a conservative approximation;

$42.3 * 10^{-6}$  – is the number of kmol per m<sup>3</sup> of gas referenced at 101.325 kPa and 15<sup>0</sup>C (i.e.  $42.3 * 10^{-3}$ ) times a unit conversion factor of 10<sup>-3</sup> Gg/Mg which brings the results of each applicable equation to units of Gg/y.

To adopt above equation for the calculations of CO<sub>2</sub> emissions in the PDD, further simplifications were considered:

In the right part of the above equation the product  $\text{GOR} * Q_{\text{oil}}$  is the volume of resulting APG. Associated gas is not conserved that is why  $\text{CE}$  is equal to 0. Product of  $M_{\text{CO}_2}$  and  $42.3 * 10^{-6}$  is the density of CO<sub>2</sub> taken at 15<sup>0</sup>C. As the volumes of all burned gases are given at 20<sup>0</sup>C in further calculation, CO<sub>2</sub> density will be given at this temperature.  $X_{\text{Soot}}$  – in this case is incomplete combustion. Therefore above equation is converted into the following:



$$EF_{CO_2,F} = X_{APG,F} \cdot \rho_{CO_2} \cdot \{y_{CO_2} + (N_{C_{CH_4}} \cdot y_{CH_4} + N_{C_{C_2H_6}} \cdot y_{C_2H_6} + N_{C_{C_3H_8}} \cdot y_{C_3H_8} + N_{C_{C_4H_{10}}} \cdot y_{C_4H_{10}} + N_{C_{C_4H_{10}}} \cdot y_{C_4H_{10}} + N_{C_{C_5H_{12}}} \cdot y_{C_5H_{12}} + N_{C_{C_6H_{14}}} \cdot y_{C_6H_{14}} + N_{C_{C_7H_{16}}} \cdot y_{C_7H_{16}} + N_{C_{C_8H_{18}}} \cdot y_{C_8H_{18}} + N_{C_{H_2S}} \cdot y_{H_2S})(1 - X_{ub})\}$$

**Where:**

$X_{APG,F}$  - APG amount burned in flares but not vented;

$\rho_{CO_2}$  - CO<sub>2</sub> density at 20<sup>0</sup>C, kg/m<sup>3</sup>;

$X_{ub}$  - incomplete combustion coefficient;

$y_{CO_2}$  - volume fraction of APG that is composed of CO<sub>2</sub>;

$N_{C_{CH_4}}$  - number of moles of carbon per mole of methane;

$y_{CH_4}$  - volume fraction of APG that is composed of CH<sub>4</sub>;

$N_{C_{NMVOC}}$  - number of moles of carbon per mole of non-methane volatile organic compounds including ethane C<sub>2</sub>H<sub>6</sub>, butane C<sub>3</sub>H<sub>8</sub>, propane C<sub>4</sub>H<sub>10</sub>, pentane C<sub>5</sub>H<sub>12</sub>, hexane C<sub>6</sub>H<sub>14</sub>, heptanes C<sub>7</sub>H<sub>16</sub>, octane C<sub>8</sub>H<sub>18</sub>).



Annex 3

**MONITORING PLAN**

Section D specifies all key features of project monitoring plan.

Annex 4**List of abbreviations**

AIE	Accredited Independent Entity
APG	Associated petroleum gas
BCS	Buster compressor station
BFLH	Broad fraction of light hydrocarbons
BPS	Buster pump station
CDM	Clean development mechanism
CS	Compressor station
DPP	Discounted Payback Period
EF	Emission factor
ERU	Emission reduction unit
GRTD	Gas Recovery and Transportation Department
GTI	Gas treatment installation
GTPP	Gas turbine power plant
GTU	Gas turbine unit
HVL	High-voltage line
IPCC	Intergovernmental panel on climate change
IRR	Internal Rate of Return
JI	Joint implementation
LHMM	Light hydrocarbons multicomponent mixture
LoA	Letter of Approval
LLC	Limited Liability Company
NG	Natural gas
NOAA	National Oceans and Atmosphere Agency (United States)
NPV	Net Present Value
OS	Outdoor switchgear
OTTW	Oil treatment and transit workshop
PDD	Project design document
PWDU	Preliminary water discharge unit
RUB	Russian Ruble
UNFCCC	United Nations Framework Convention on Climate Change
UES	United electricity system
VAT	Value added tax
YB GPP	Yuzhno-Balyksky gas processing plant