



JOINT IMPLEMENTATION PROJECT DESIGN DOCUMENT FORM
Version 01 - in effect as of: 15 June 2006

CONTENTS

- A. General description of the project
- B. Baseline
- C. Duration of the project / crediting period
- D. Monitoring plan
- E. Estimation of greenhouse gas emission reductions
- F. Environmental impacts
- G. Stakeholders' comments

Annexes

- Annex 1: Contact information on project participants
- Annex 2: Baseline information
- Annex 3: Monitoring plan

**SECTION A. General description of the project****A.1. Title of the project:**

Joint Implementation project aimed at N₂O emissions reduction by installation of secondary catalyst inside ammonia oxidation reactors at 3 nitric acid production plants NA2, NA3 and NA4 of Azomures SA company, situated at Tirgu Mures, Romania.

Version 1.0, date of the PDD completion April 2008.

A.2. Description of the project:

Purpose of the project is the reduction of nitrous oxide emissions from the three nitric acid production plants NA2, NA3 and NA4 at the Azomures SA (“Azomures” or “the Company”). The company is situated in Tirgu Mures, Mures county, Romania.

N₂O formation is a result of unwanted chemical reaction that takes place during ammonia oxidation which is the first stage in the nitric acid production process. Some part of N₂O is destroyed already in the ammonia oxidation reactor, while the rest is carried out with the tail gases.

Azomures is planning to reduce N₂O emissions is by installing secondary N₂O reduction catalyst underneath the primary catalyst precious metal catching and catalytic gauzes package in the ammonium burner. This N₂O abatement technology will be applied at three nitric acid production plants NA2, NA3 and NA4. Secondary catalysts will be installed in all ammonia oxidation reactors of three nitric acid plants. According to guarantees provided by major secondary catalyst suppliers installation of the secondary catalysts will allow more than 70% reduction of the N₂O content in the tail gas.

Baseline scenario has been identified as continuation of recent situation and baseline measurements have been executed from March 2007 according to requirements of the CDM approved methodology AM0034.

Since there is in Romania no regulation controlling N₂O emission caps and the catalyst is not an essential part of the acid production process, the implementation of the Project is voluntary and functionally serves only environmental purposes. The sole economic motivation for the Project is the income from the sale of Emission Reductions. Hence the decision to install the catalyst depends on the participation in a Joint Implementation project.

N₂O is a very potential greenhouse gas - comparing to the CO₂ it has 310 higher greenhouse warming potential. Reduction of N₂O has a very high importance from the view of climate change mitigation measures. Given that Azomures is one of the major producers of nitrogen fertilizers in Romania, N₂O abatement at this plant will be very significant for the overall climate change mitigation measures undertaken in Romania.

A.3. Project participants:

| Party involved ((host) indicates a host Party) | Private and/or public entity(ies) project participants (*) (as applicable) | Party involved wishes to be considered as project participant (Yes/No) |
|---|---|---|
| Romania (Host) | Private entity Azomures SA (Project Owner) | No |
| | Private entity Vertis | No |



| | | |
|--|--|--|
| | Environmental Finance Zrt (JI Project Advisor) | |
|--|--|--|

A.4. Technical description of the project:**A.4.1. Location of the project:****A.4.1.1. Host Party(ies):**

Romania

A.4.1.2. Region/State/Province etc.:

Mures county

A.4.1.3. City/Town/Community etc.:

Tirgu Mures

A.4.1.4. Detail of physical location, including information allowing the unique identification of the project (maximum one page):

Address:
Azomures SA
Gh. Doja str., no. 300
540237 TIRGU MURES
ROMANIA



Source: <http://www.infoplease.com/atlas/country/romania.html>



Source: Google Earth

Geographical coordinates of the plant are 46° 31'22 N; 24° 30'46 E

**A.4.2. Technology(ies) to be employed, or measures, operations or actions to be implemented by the project:****Nitrous oxide formation**

The technology of acid production can be broken down into the following main steps:

1. ammonia oxidation (combustion)
2. absorption
3. tail gas purification.

The oxidation of ammonia and the absorption can occur at low (1-3 bar), medium (4-7 bar) or high (8-12 bar) pressure. Low pressure and high pressure support oxidation and absorption, respectively. From a technological point of view, the technology is optimal if combustion occurs at low pressure and absorption at high pressure. This so-called dual pressure technology includes an intermediate compression between the two stages. During the oxidation of ammonia, a 1:10 mixture of ammonia and air is driven through a primary catalyst in the ammonia oxidation reactor, where the following reactions take place:

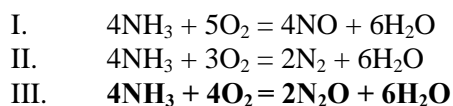

The reactions take place on a primary catalyst at a temperature of around 850°C in a way that prevents side reactions II and III from occurring as much as possible, because these reactions have a negative effect on the rate of NO generation. Depending on the quality and condition of the catalyst utilization and on the residence time of combustion gases until their exit from ammonia oxidation reactor partial natural decomposition of N₂O may happen to a certain degree in the presence of high temperature. The rest of the N₂O gas proceeds along the nitric acid production process, being partially decomposed if tail gas reheating takes place before the inlet into the gas turbine, and exhausted through the stack at the end.

Primary catalyst consists of several knitted or woven gauzes made of platinum/rhodium alloy to achieve desired NO generating chemical reaction and increase the life cycle of the catalyst and decrease its maintenance costs. During ammonia oxidation process catalyst loses some of its platinum and rhodium content which is recovered by 60%-80% into the platinum catchment system, installed under the catalyst. After a certain period of time called campaign catalyst undergoes substitution.

The water formed during the ammonia oxidation process is condensed in a cooler-condenser and transferred to the absorption tower. Nitric oxide (NO) generated in the reaction I is further oxidised to nitrogen dioxide (NO₂) by the oxygen content of air which is added to cooled combustion gases formed during the ammonia oxidation process:

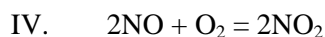

Nitrogen dioxide (NO₂) proceeds further into the absorption tower where the generation of nitric acid takes place due to the reaction with counter currently flowing water.



Higher pressure and lower temperature favour the reaction inside the absorber. Generated nitric acid is then bleached by the secondary air to purify it from dissolved nitrogen oxides. Not absorbed tail gases leave absorption tower to be heated further in the waste heat boilers (superheaters), after which they pass through an NO_x abatement system and through a tail gas expander (gas heat exchanger) in order to recover the energy. Finally partially purified tail gas leaves through the stack.

History of the plant

Description of the plant

There are 3 nitric acid plants in Azomures.

Nitric acid plant 2 (NA2) was technologically designed by the DIDIER. It was constructed and commissioned in 1966. NA2 plant has its own ammonia and air preparation and feeding system, 3 ammonia oxidation chambers, heat exchange system, turbine, absorption tower and stack with individual production schedules (production, shut-downs, primary catalyst gauze changes, operating conditions). NA2 uses dual pressure technology with oxidation pressure 4bar and absorption pressure 8bar. Nameplate capacity of the NA2 plant is 725 tHNO₃/day. Actual production capacity of nitric acid plant NA2 depends on number of operational hours per year and production load used. The time length of the primary catalyst campaign in the ammonia oxidation reactor is, based on length of 4 previous campaigns, in average 526 days with average HNO₃ production 239,967 tHNO₃ per campaign. There is Rhodia de-NO_x SCR facility installed.

At present the plant does not use any N₂O emissions reduction technology.

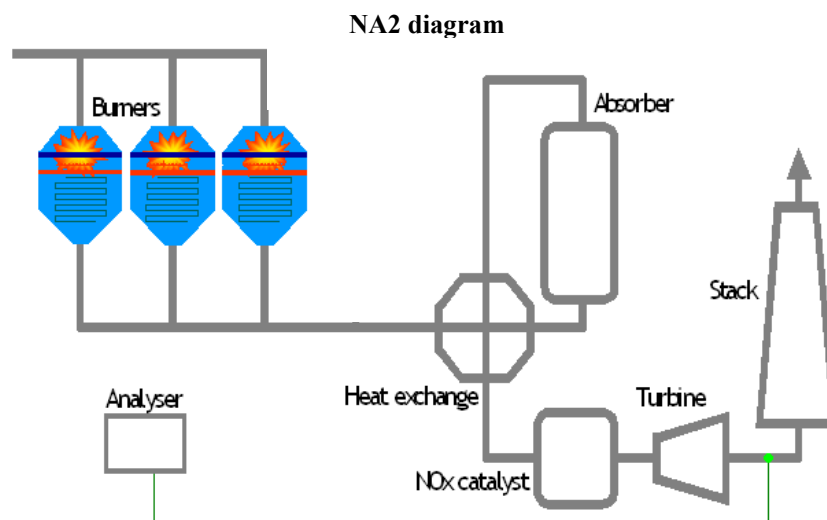

Nitric acid plant 3 (NA3) was technologically designed by the Grande Paroisse. It was constructed and commissioned in 1974. NA3 plant has its own ammonia and air preparation and feeding system, 4 ammonia oxidation chambers, heat exchange system, turbine, absorption tower and stack with individual production schedules (production, shut-downs, primary catalyst gauze changes, operating conditions). NA3 uses dual pressure technology with oxidation pressure 3.6bar and absorption pressure 8bar. Nameplate capacity of the NA3 plant is 725 tHNO₃/day. Actual production capacity of nitric acid plant NA3 depends on number of operational hours per year and production load used. The time length of the primary catalyst campaign in the ammonia oxidation reactor is, based on length of 4 previous campaigns, in average 533 days with average HNO₃ production 337,384 tHNO₃ per campaign. There is Rhodia de-NO_x SCR facility installed.

At present the plant does not use any N₂O emissions reduction technology.

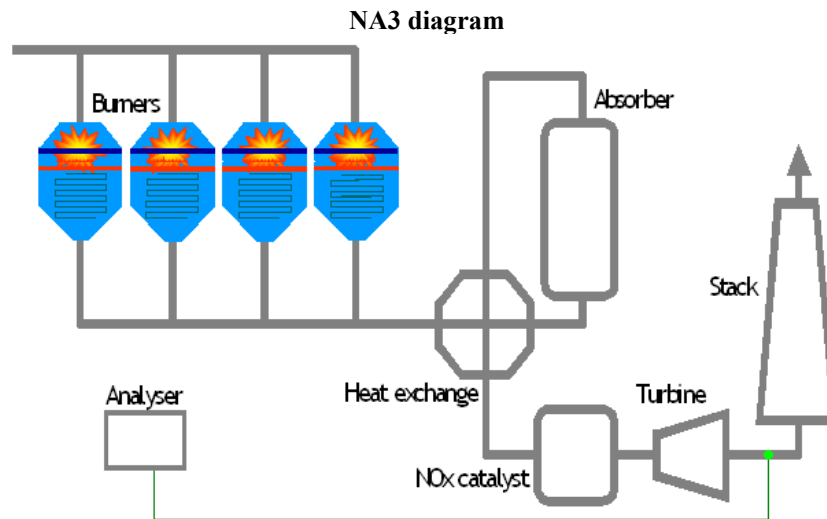

Nitric acid plant 4 (NA4) was technologically designed by the Grande paroisse. It was constructed and commissioned in 1978. NA4 plant has its own ammonia and air preparation and feeding system, 4 ammonia oxidation chambers, heat exchange system, turbine, absorption tower and stack with individual production schedules (production, shut-downs, primary catalyst gauze changes, operating conditions). NA4 uses dual pressure technology with oxidation pressure 4bar and absorption pressure 8bar. Nameplate capacity of the NA4 plant is 750 tHNO₃/day. Actual production capacity of nitric acid plant NA4 depends on number of operational hours per year and production load used. The time length of the primary catalyst campaign in the ammonia oxidation reactor is, based on length of 4 previous campaigns, in average 513 days with average HNO₃ production 275,776 tHNO₃ per campaign. There is Rhodia de-NO_x SCR facility installed.

At present the plant does not use any N₂O emissions reduction technology.

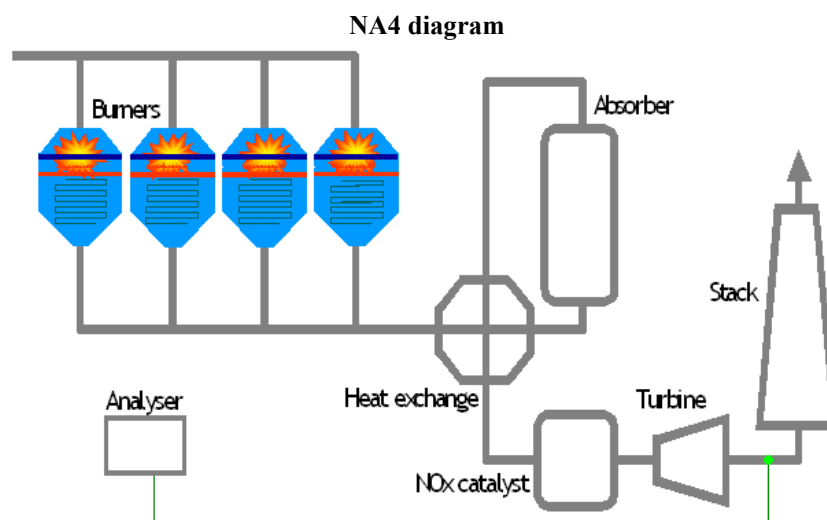

Nitrous oxide abatement technology used in the project



There are two types of technologies for the catalytic decomposition of N₂O, both of which are rather new, and there is only limited industrial experience with the use of these catalysts: the secondary catalyst which is installed in the main ammonia oxidation chamber beneath the main platinum gauzes for producing NO; and the tertiary catalyst which is contained in a separate vessel into which the tail gas from the oxidation chamber are conducted.

In the presence of the secondary catalyst at temperatures zone between 800°C and 950°C, the N₂O breaks down into N₂ and O₂ following the reaction:

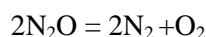

Neither of these gases are greenhouse gases. A secondary N₂O de-composing catalyst will be installed beneath the primary catalyst. Secondary catalyst will be placed in the appropriate support structure.

The secondary catalyst causes approximately from 70% up to 95% of the N₂O to be destroyed.

The technology will be provided by a major secondary catalyst manufacturer.

For information about the technology installed for measuring and recording the emissions of nitrous oxide from the plant, see the section D.1.2. below.

A.4.3. Brief explanation of how the anthropogenic emissions of greenhouse gases by sources are to be reduced by the proposed JI project, including why the emission reductions would not occur in the absence of the proposed project, taking into account national and/or sectoral policies and circumstances:

Brief description of additionality discussed in B.2.

Business as usual is not to install the nitrous oxide abatement system. There are three principal reasons for this. First, there is no legal obligation to install such a system. Romanian law does not require any abatement of nitrous oxide. Thus there is no requirement to abate nitrous oxide.

Second, there is no economic benefit to the installation of a nitrous oxide abatement system except for the revenue from the sale of Emission Reduction Units within the framework of this JI project.

Installation of N₂O abatement technology is not a common practice in Romania, as at least two such projects in Central and Eastern Europe are known not to have worked first time, leading to stoppage in production. It is only within the framework of the JI project that the installation of the N₂O abatement equipment has any economic rationale and risk justifying solution.

A.4.3.1. Estimated amount of emission reductions over the crediting period:

| Length of the crediting period Year | Years |
|--|--|
| | 5 |
| | Estimate of annual emission reductions in tonnes of CO ₂ equivalent |
| 2008 | 539,590 |
| 2009 | 1,341,086 |
| 2010 | 1,374,655 |
| 2011 | 1,374,655 |
| 2012 | 1,374,655 |



| | |
|--|-----------|
| Total estimated emission reductions over the crediting period (tonnes of CO ₂ equivalent) | 6,004,641 |
| Annual average of estimated emission reductions over the crediting period (tonnes of CO ₂ equivalent) | 1,200,928 |

A.5. Project approval by the Parties involved:

Azomures JI project received the Letter of Endorsement from Romanian Ministry of Environment in January 2008.

SECTION B. Baseline

B.1. Description and justification of the baseline chosen:

Summary description of the baseline

The baseline methodology is based on CDM methodology AM0034.

The baseline chosen is the level of nitrous oxide emissions of the plant in the absence of the project. It reasonably represents the anthropogenic emissions by sources that would occur in the absence of the project. Baseline covers GHG emissions from all sources within the project boundary. Baseline is established on the project-specific basis. Baseline emissions factor shall be established in a transparent manner based on measurements and data calculations described later in this document. Baseline takes into account all relevant national and sectoral policies and circumstances. Baseline chosen does not allow the project to earn emission reduction units (ERUs) for decreases in activity levels outside the project activity or due to force majeure. Baseline takes into account uncertainties and uses conservative assumptions.

Justification of the methodology

This baseline approach is used for the following reasons:

1. It is based on an approved CDM methodology and therefore incorporates a level of scientific rigour which has already been approved by the UNFCCC methodology panel
2. It meets the conditions of applicability of AM0034/Version 02 since:
 - a. The facility was established before 31st December 2005
 - b. The facility has no existing N₂O abatement technology, hence, no impact on the work of it could be done by the project activity
 - c. The project will not affect the plant's nitric acid production levels
 - d. There are no requirements in the host country to reduce N₂O emissions
 - e. There is no N₂O abatement technology installed at the plant
 - f. The project activity will not increase NO_x emissions
 - g. There is no non-selective catalyst installed for the reduction of NO_x
 - h. The project will not lead to any material change in other greenhouse gas emissions within the project boundary
 - i. Continuous monitoring of the N₂O concentration and tail gas flow has been installed for the duration of a campaign for the measurement of baseline emissions, and thereafter

In the Identification of the baseline scenario we list first barriers named in the AM0028 methodology and we specifically mark cases (n/a), when some of these barriers do not apply to the project.



Identification of the baseline scenario

For identification of the baseline scenario the procedure of the CDM methodology AM0028/Version 04.1 has been used, in accordance with the suggestion of the CDM methodology AM0034/Version 02.

Step 1a

Step 1a of a baseline scenario identification includes listing of all technically feasible alternatives to the given project. The principal theoretical alternatives to the project are:

- Continuing to operate the plant as is
- Switch to alternative production method not involving ammonia oxidation process
- Alternative use of N₂O such as:
 - Recycling of N₂O as a feedstock for the plant
 - The use of N₂O for external purposes
- Installation of Non-Selective Catalytic Reduction (NSCR) De-NO_x system
- Installation of N₂O abatement not as a JI project
- Installation of an N₂O destruction or abatement technology:
 - Tertiary measure for N₂O destruction
 - Primary or secondary measures for N₂O destruction or abatement

Step 1b

This step includes all possible technically feasible options to handle NO_x emissions. Non-Selective De-NO_x units cause also reduction of N₂O and thus it is necessary to elaborate also on this technical option. Possibilities regarding NO_x emissions are as following:

- Continuation of the current situation, whether either De-NO_x units is installed or not
- Installation of new Selective Catalytic Reduction De-NO_x unit
- Installation of a new Non-Selective Catalytic reduction (NCSR) De-NO_x unit
- Installation of a new tertiary measure that combines NO_x and N₂O emission reduction

Step 2

Eliminate baseline alternatives that do not comply with legal or regulatory requirements

There are no regulatory requirements in Romania regarding N₂O emissions. NO_x emissions are regulated by the Approval of Integrated Pollution Prevention and Control. Azomures has installed at all 3 nitric acid plants a Selective Catalytic Reduction De-NO_x units:

All alternatives could comply with relevant legal regulations.

Step 3

Eliminate baseline alternatives that face prohibitive barriers (barrier analysis)

Step 3a

On the basis of the alternatives that are technically feasible and in compliance with all legal and regulatory requirements establish a complete list of barriers that would prevent alternatives to occur in the absence of JI. Barriers include, among others:

- Investment barriers, *inter alia*:
 - Debt funding is not available for this type of innovative project activity
 - Debt funding is not available due to no project return without JI
 - No access to international capital markets due to perceived risks associated with domestic or foreign direct investment in the country where the project activity is to be implemented (n.a.)
- Technological barriers, *inter alia*:



- Technical and operational risks of alternatives
 - Technical efficiency of alternatives (e.g. N₂O destruction, abatement rate)
 - Skilled and/or properly trained labour to operate and maintain the technology is not available and no education/training institution in the host country provides the needed skill, leading to equipment disrepair and malfunctioning (n.a.)
 - Lack of infrastructure for implementation of the technology (n.a.)
- Barriers due to prevailing practice, *inter alia*:
- The project activity is the “first of its kind”: No project activity of this type is currently operational in the host country or region

Since Romania is the EU Member State with corresponding level of industrial development we have used for elimination of possible alternatives mainly technical and operational risks of alternatives and technical efficiency of alternatives criteria (i.e. there is no barrier in form of no access to international capital markets, lack of infrastructure or lack of skilled personnel as Azomures is capable of implementing and operating a de-N₂O project).

Nitric acid production in industrial facilities such as Azomures plant is not possible to be changed in a way not involving the ammonia oxidation process.

Alternative use of N₂O is neither technologically nor economically feasible. It is not possible to recycle N₂O in order to use it for the nitric acid production, neither it is technically and economically feasible to use N₂O for external purposes.

Installation of NSCR is also not feasible from technological and economic points of view due to high energy costs, high gas temperatures required, emissions of CO and hydrocarbons to the air. N₂O emission levels are also higher than with Selective Catalytic Reduction (SCR) and it is a very expensive abatement technology both in terms of investments and operation costs. The Azomures plant has installed selective catalyst reduction system which reduces NO_x emission level below the limits established by Azomures' IPPC permit.

Since reduction of N₂O represents significant investments for installation, burner modifications and following costs of operation of the De-N₂O system it is not economically feasible to implement a De-N₂O project without use of financing provided through JI.

Tertiary De-N₂O reduction is not economically feasible in the Azomures plant as it would require principal changes to complete design of nitric acid production lines and NO_x emissions abatement is handled by installation of Selective Catalytic reduction unit.

Recent level of the ammonia oxidation catalyst development does not allow to implement de-N₂O project using primary catalyst as the De-N₂O reduction component.

It is important to note that Azomures by implementation of the de-N₂O project contributes to environmentally friendly innovativeness of the chemical industry, nitric acid production specifically.

Recently there are no operational secondary catalyst de-N₂O projects in the region and there is no experience with operation of secondary catalyst inside UKL-7 type oxidation burners.

By March 2008 there have been published on the UNFCCC website (http://ji.unfccc.int/JI_Projects/Verification/PDD/index.html) in total 6 de-N₂O projects, which have proceeded into the PDD publication stage. Two projects are being implemented in Poland (Anwil, ZAT), two projects in Russian Federation (OJSC Cherepovetsky Azot, OJSC Kuibyshev Azot) and two are JI



projects implemented by Achema in its UKL-7 plants (projects described in this PDD) and in the GP plant. None of these projects has received determination report yet.

Step 3b

Based on the reasons listed in the Step 3a above we have eliminated in this step following alternatives:

- Switch to alternative production method not involving ammonia oxidation process
- Alternative use of N₂O such as:
 - Recycling of N₂O as a feedstock for the plant
 - The use of N₂O for external purposes
- Installation of Non-Selective Catalytic Reduction (NSCR) De-NO_x system
- Installation of N₂O abatement not as a JI project
- Installation of an N₂O destruction or abatement technology:
 - Tertiary measure for N₂O destruction
 - Primary measures for N₂O destruction or abatement

Only remaining alternative achieving N₂O emission reduction, other than continuation of Status Quo, is secondary catalytic reduction of N₂O in existing reaction chambers of ammonia oxidation reactors.

Step 4

Identify the most economically attractive baseline scenario alternative

Implementation of installation of the secondary De-N₂O catalyst, itself does not generate any financial profit. Since it is only alternative left after elimination of other alternatives in steps 2 and 3, it is not necessary to conduct further simple cost analysis, which would otherwise appropriate to this alternative.

Step 5

Re-assessment of Baseline Scenario in course of proposed project activity's lifetime

Sub-step 5a

Azomures nitric acid plant has installed a Selective Catalytic Reduction De-NO_x units in order to comply with existing NO_x regulations in Romania. SCR De-NO_x unit leads to higher N₂O formation and its intensification would lead to higher emission reductions. Thus change in the NO_x regulations would not necessitate re-assessment of the Baseline Scenario, because it would actually increase its level of required conservativeness.

Sub-step 5b

In case of introduction of either concentration or mass limits of N₂O emission the Baseline Scenario would be re-assessed according to new regulations.

Note on variation on AM0034 for application on this project

1. Multiple plants

The plant actually consists of 3 separate plants comprising four production units of burner (NA2 has 3 burners), one absorption tower, De-NO_x system, and tail gas turbine. The emissions from the tail gas turbines are led to stack bars individual for each plant and emitted to the air.

Because of this, baseline emissions are measured separately from each plant and a separate baseline factor is calculated for each plant. Similarly, project emissions are recorded for each plant. The number of emissions reductions of the project is the sum of emission reductions for each separate plant.

2. Overlapping of consecutive campaigns



AM0034 requires that the baseline factor should be established through measuring emissions during an entire campaign. The plant has three separate lines, and the timing of the campaigns of these lines is staggered.

N₂O emissions monitoring system has been installed on all three lines in March 2007.

Baseline measurements on line NA2 started in July 2007 at the beginning of a campaign and shall be completed in August 2008. Baseline measurements shall be carried during entire duration of one campaign.

Baseline measurements on line NA3 started in March 2007 at the beginning of a campaign and shall be completed in May 2008. Baseline measurements shall be carried during entire duration of one campaign.

Baseline measurements on line NA4 started in August 2007 during course of then campaign, which started in September 2006. Production of nitric acid from date of installation of N₂O monitoring (August 2007) until end of then campaign (January 2008) was 96.152 tHNO₃. Baseline measurements then continued from beginning of following campaign, which started in February 2008 and shall be completed in August 2008, when earliest possible date for installation of secondary catalysts on line NA4 shall occur. It is expected by that time nitric acid production shall reach level of 120,000 tHNO₃. In combination with emission data from previous campaign there will be available data from later stage of previous campaign and earlier stage of current campaign. By overlapping data from two consecutive campaigns with materially same operating conditions it will be possible to establish baseline factor and install secondary catalysts in August 2008.

| |
|--|
| B.2. Description of how the anthropogenic emissions of greenhouse gases by sources are reduced below those that would have occurred in the absence of the JI project: |
|--|

This section provides proofs of the project additionality, i.e. proofs demonstrating importance of the JI project implementation for greenhouse gas reduction that would not have been achieved in the business-as-usual scenario. “*Tool for the demonstration and assessment of additionality*” (version 03) is used as a reference for proving attractiveness of chosen JI project alternative in front of other possible alternatives.

Step 1

Identification of alternatives to the project activity consistent with current laws and regulations

As suggested by the CDM methodology AM0034 Step 1 has been omitted because B.1 section identifying and describing baseline scenario has already identified continuation of the Status Quo as the only realistic alternative to the chosen project scenario, which is also consistent with mandatory laws and regulations of Romania.

Step 2

Investment analysis

Investment analysis is the next step undertaken in order to prove the necessity of ERUs revenues for the project implementation that otherwise would not be financially attractive.

As described in section “Identification of the baseline scenario”, in the absence of the JI project, there is no installation of any equipment which would reduce N₂O emissions, and the business continues as usual. This means that there is no reduction of N₂O emissions and they would remain at recent level.

Step 2b

Simple Cost Analysis



In terms of simple cost, implementation of proposed JI project would mean significant cost for the project owner. JI project directed on installation of N₂O abatement system in Azomures plant will incur the costs of secondary catalyst installation in all eleven ammonia oxidation reactors of 3 plants. Besides catalyst design and transportation costs the plant will have to carry the costs of ammonia oxidation reactors' modification. The plant will have to pay secondary catalyst leasing fee plus the costs of catalyst replacement and maintenance. Equipment for monitoring baseline N₂O emissions and emissions of N₂O after the project implementation requires additional costs for its design, transportation, maintenance, servicing and certification in accordance with the CDM methodology AM0034 requirements.

Step 3

Barrier analysis

Step 3 is omitted because the "*Tool for the demonstration and assessment of additionality*" (version 03) allows the use of alternatively Step 2 or Step 3 for the proof of additionality.

Step 4

Common practice analysis

This step allows to double check for the previous proofs of the project additionality demonstrating that besides being the only plausible alternative from financial point of view the project also introduces innovative practice in the industry of the region regarding greenhouse gas abatement activity.

Introduction of N₂O abatement technology is not common practice for nitric acid industry mainly because there are no incentives for N₂O abatement due to the absence of regulation imposing N₂O emission limits. In case of Romania, in particular, high costs of project implementation and absence of N₂O emission limiting regulation make N₂O abatement activity to be not attractive for local nitric acid production industry. On the other hand N₂O abatement activity is known to be widespread practice among nitric acid plants implemented as CDM or JI projects, which proves this activity to be rather attractive in a framework of Kyoto Protocol project flexibility instruments.

Conclusion

Implementation of the N₂O abatement project in the JI framework is the only way to make the introduction of N₂O abatement technology financially feasible for the plant. Installation of the secondary N₂O abatement catalyst is state-of-art technology, hence, not widely spread among nitric acid production plants. Because of its modernity this technology is quite costly and it does not represent for the plant any financial benefit. The only advantage of N₂O abatement is reduction of this potential greenhouse gas in order to introduce climate change mitigation measures. Given that national/local regulations do not foresee N₂O emission limits the JI project implementation and the use of ERUs sale proceeds is the only possible solution for reducing N₂O emissions at the nitric acid plant of Azomures.

B.3. Description of how the definition of the project boundary is applied to the project:

Project boundary encompasses all anthropogenic emissions by sources of GHGs which are under the control of project participants, are reasonably attributable to the project and are significant. Project boundary and greenhouse gas sources relevant for the project implementation are individuated in accordance with the Approved Consolidated Methodology AM0034 “Catalytic reduction of N₂O inside ammonia burner of nitric acid plants”.

According to the methodology the project boundary shall cover the facility and equipment for the complete nitric acid production process. The following diagram identifies the borders where N₂O emission reduction project will take place in 3 nitric acid plants (one single diagram demonstrates project boundary for all 3 nitric acid plants taking into account only difference between them is number of burners in NA2 comparing to NA3 and NA4). The chart below shows major stages of the nitric acid production, points where gas analysers are installed in order to monitor baseline emissions of nitrous oxide, and placement of secondary catalysts applied for N₂O abatement. The process of nitric acid production and N₂O abatement is identical on two production lines. The inlet of ammonia into the ammonia oxidation reactors of both lines is the first point in the project boundary and the gas emission from the stacks is the last point in the nitric acid production process included into the project boundary.

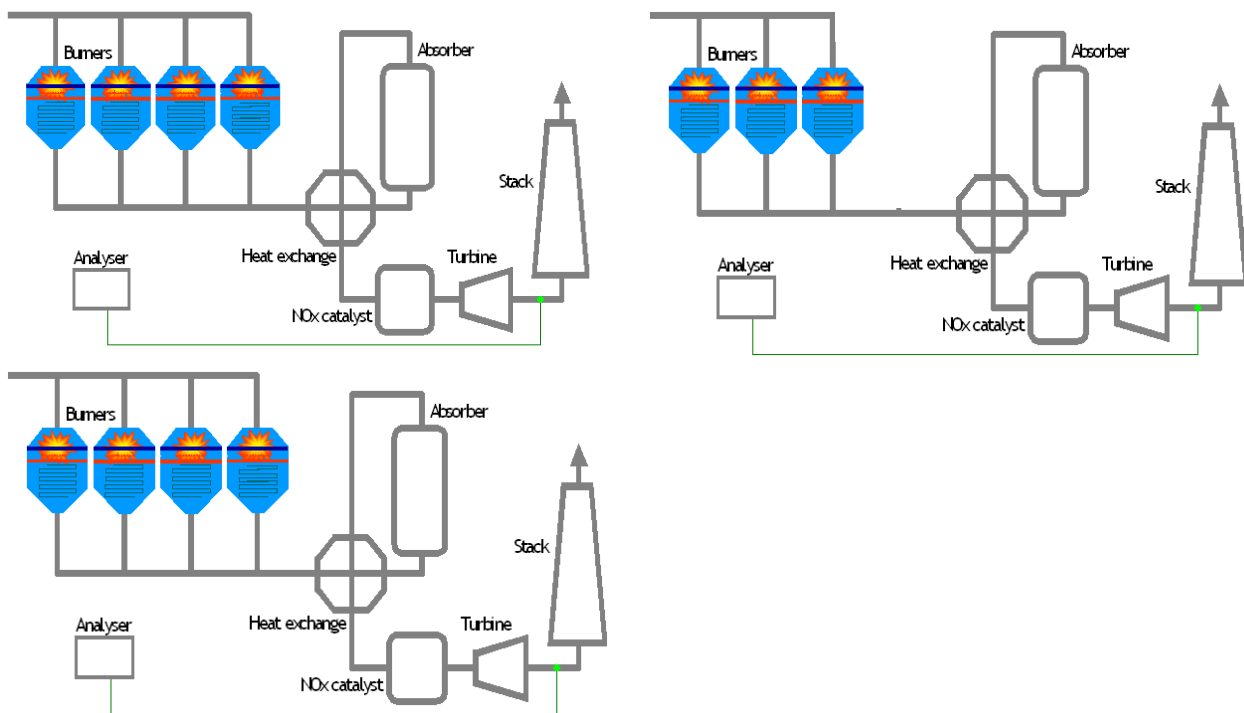

- Primary catalyst
- N₂O abatement cat.
- Monitoring point
- Sampling pipes



The only greenhouse gas to be considered in the implementation of the N₂O abatement project at the nitric acid plant is the N₂O.

| | Source | Gas | Inclusiveness | Justification /Explanation |
|------------------|--|------------------|---------------|---|
| Baseline | Nitric Acid Plant (Burner inlet to stack) | CO ₂ | Excluded | N ₂ O abatement project does not lead to any change in CO ₂ and CH ₄ emissions |
| | | CH ₄ | Excluded | |
| | | N ₂ O | Included | |
| Project activity | Nitric Acid Plant (Burner inlet to stack) | CO ₂ | Excluded | N ₂ O abatement project does not lead to any change in CO ₂ and CH ₄ emissions |
| | | CH ₄ | Excluded | |
| | | N ₂ O | Included | |
| | Leakage emissions from production, transport, operation and decommissioning of the secondary catalyst. | CO ₂ | Excluded | No leakage emissions are expected. |
| | | CH ₄ | Excluded | |
| | | N ₂ O | Excluded | |

B.4. Further baseline information, including the date of baseline setting and the name(s) of the person(s)/entity(ies) setting the baseline:

>>

Baseline will be set after completion of baseline measurements. Estimated date for baseline setting is May 2008 for NA3, August 2008 for NA2 and August 2008 or June 2009 for NA4.

| | |
|---------------------|--|
| Contact person | Laszlo Pasztor |
| Company | Vertis Environmental Finance |
| Project participant | No |
| Address | H-1123 Budapest, Alkotás utca 39/c, Hungary |
| Phone | +36 1 488 8423 |
| Fax | +36 1 488 8411 |
| Email | laszlo.pasztor@vertisfinance.com |
| Web page | www.vertisfinance.com |

Vertis Environmental Finance is not the Project participant.

SECTION C. Duration of the project / crediting period

C.1. Starting date of the project:

September 20, 2006

C.2. Expected operational lifetime of the project:

The project is expected to operate beyond 31st December 2012.

C.3. Length of the crediting period:

The period of claim on Emission Reduction Units (ERUs) is from 1 January 2008 till 31 December 2012.

**SECTION D. Monitoring plan****D.1. Description of monitoring plan chosen:**

In order to establish a definitive baseline, N₂O measuring instruments were installed in the lines in the plants NA2, NA3 and NA4. Continuous measurements were made. To ensure the integrity of the data from these measurements and the suitability of the data for inclusion in the Baseline Study within the Project Design Documentation, the measurements will be validated by an Accredited Independent Entity - respected and experienced validator in the field of Joint Implementation.

N₂O emissions monitoring system consists of the measurement devices part and data processing and storage part.

MONITORING SYSTEM DESCRIPTION NITRIC ACID 2 PLANT**A. Main air flow**

- the measuring point is located on the compressor air discharge pipe
- diaphragm type sensor with ring-like chambers
- operating conditions: p = 2.5 – 3 bars, t = 150°C
- pneumatic signal transmission between the sensor and the transducer through 2 impulse pipes, approx. 10 m long
- measuring device: Fischer Roesmount differential electronic transducer, having a measuring range between 0 – 45.24 mbar; output signal: analogue 4 – 20 mA
- signal transmission: electric wires, approx. 30 m long, analogue signal 4 – 20 mA
- signal conversion device: ISU 24M digital indicator; placed inside the control panel; converts the analogue signal into digital signal; recording period: 2 seconds.
- data recorded into the “data logger” are transmitted through an optic fiber network to a computer designated particularly for this type of monitoring. This computer is located in the Instrumentation Plant. Data are stored in a database on the computer’s hard disk. From this database data are afterwards processed in order to obtain all data necessary for the project. The entire database is periodically saved on graphic and magnetic support as an Excel file.

B. Secondary air flow

- the measuring point is located on the air compressor discharge pipe
- diaphragm type sensor with ring-like chambers



- operating conditions: $p = 2.5 - 3$ bars, $t = 150^{\circ}\text{C}$
- pneumatic signal transmission between the sensor and the transducer through 2 impulse pipes, approx. 15 m long
- measuring device: Fischer Roesmount differential electronic transducer, having a measuring range between 0 – 500 mm H₂O; output signal: analogue 4 – 20 mA
- signal transmission: electric wires, approx. 50 m long, analogue signal 4 – 20 mA
- signal conversion device: ISU 24M digital indicator; placed inside the control panel; converts the analogue signal into digital signal; recording period: 2 seconds.
- data recorded into the “data logger” are transmitted through an optic fiber network to a computer designated particularly for this type of monitoring. This computer is located in the Instrumentation Plant. Data are stored in a database on the computer’s hard disk. From this database data are afterwards processed in order to obtain all data necessary for the project. The entire database is periodically saved on graphic and magnetic support as an Excel file.

C. Reactor sieves temperature

- the measuring point is located on the oxidation reactor; sensor; PtRh-Pt thermocouple, operating conditions: $t = 800 - 1000^{\circ}\text{C}$
- electric signal transmission between the sensor and the transducer: PtRh-Pt correction cable, approx. 50 m long
- digital indicator measuring device; measuring range between 0 – 1000°C; analogue output signal 4 – 20 mA
- signal transmission: electric wires, approx. 6 m long, analogue signal 4 – 20 mA
- signal conversion device: ISU 24M digital indicator; placed inside the control panel; converts the analogue signal into digital signal; recording period: 2 seconds.
- data recorded into the “data logger” are transmitted through an optic fiber network to a computer designated particularly for this type of monitoring. This computer is located in the Instrumentation Plant. Data are stored in a database on the computer’s hard disk. From this database data are afterwards processed in order to obtain all data necessary for the project. The entire database is periodically saved on graphic and magnetic support as an Excel file.

D. Consumed liquid ammonia flow

- the measuring point is located on the ammonia evaporator inlet pipe; Coriolis type sensor; operating conditions: $p = 12$ bar, $t = 8 - 10^{\circ}\text{C}$
- electric signal transmission between the sensor and the transducer: 2-wire cable, approx. 90 m long
- measuring device: DZL363 flowmeter adapter produced by Endress&Hauser; measuring range between 0 – 20 t/h; analogue output signal 4 – 20 mA



- signal transmission: electric wires, approx. 10 m long, analogue signal 4 – 20 mA
- signal conversion device: ISU 24M digital indicator; placed inside the control panel; converts the analogue signal into digital signal; recording period: 2 seconds.
- data recorded into the “data logger” are transmitted through an optic fiber network to a computer designated particularly for this type of monitoring. This computer is located in the Instrumentation Plant. Data are stored in a database on the computer’s hard disk. From this database data are afterwards processed in order to obtain all data necessary for the project. The entire database is periodically saved on graphic and magnetic support as an Excel file.

E. Flow of produced nitric acid

- the measuring point is located on the column 4 outlet pipe towards the nitric acid storehouse; electromagnetic sensor; operating conditions: $p = 2.5 \text{ bar}$, $t = 40^\circ\text{C}$
- electric signal transmission between the sensor and the transducer: 2-wire cable, approx. 100 m long
- measuring device: DZL363 flowmeter adapter produced by Endress&Hauser; measuring range between 0 – 100 t/h; analogue output signal 4 – 20 mA
- signal transmission: electric wires, approx. 5 m long, analogue signal 4 – 20 mA
- signal conversion device: ISU 24M digital indicator; placed inside the control panel; converts the analogue signal into digital signal; recording period: 2 seconds.
- data recorded into the “data logger” are transmitted through an optic fiber network to a computer designated particularly for this type of monitoring. This computer is located in the Instrumentation Plant. Data are stored in a database on the computer’s hard disk. From this database data are afterwards processed in order to obtain all data necessary for the project. The entire database is periodically saved on graphic and magnetic support as an Excel file.

F. Temperature of produced nitric acid

- the measuring point is located on the column 4 outlet pipe towards the nitric acid storehouse; Coriolis type sensor; operating conditions: $p = 2.5 \text{ bar}$, $t = 40^\circ\text{C}$
- electric signal transmission between the sensor and the transducer: 2-wire cable, approx. 100 m long
- measuring device: DZL363 flowmeter adapter produced by Endress&Hauser; measuring range between $-50 - 200^\circ\text{C}$; analogue output signal 4 – 20 mA
- signal transmission: electric wires, approx. 5 m long, analogue signal 4 – 20 mA



- signal conversion device: ISU 24M digital indicator; placed inside the control panel; converts the analogue signal into digital signal; recording period: 2 seconds.
- data recorded into the “data logger” are transmitted through an optic fiber network to a computer designated particularly for this type of monitoring. This computer is located in the Instrumentation Plant. Data are stored in a database on the computer’s hard disk. From this database data are afterwards processed in order to obtain all data necessary for the project. The entire database is periodically saved on graphic and magnetic support as an Excel file.

G. Density of produced nitric acid

- the measuring point is located on the column 4 outlet pipe towards the nitric acid storehouse; Coriolis type sensor; operating conditions: $p = 2.5 \text{ bar}$, $t = 40^\circ\text{C}$
- electric signal transmission between the sensor and the transducer: 2-wire cable, approx. 100 m long
- measuring device: DZL363 flowmeter adapter produced by Endress&Hauser; measuring range between 1.2 – 1.4 kg/l; analogue output signal 4 – 20 mA
- signal transmission: electric wires, approx. 5 m long, analogue signal 4 – 20 mA
- signal conversion device: ISU 24M digital indicator; placed inside the control panel; converts the analogue signal into digital signal; recording period: 2 seconds.
- data recorded into the “data logger” are transmitted through an optic fiber network to a computer designated particularly for this type of monitoring. This computer is located in the Instrumentation Plant. Data are stored in a database on the computer’s hard disk. From this database data are afterwards processed in order to obtain all data necessary for the project. The entire database is periodically saved on graphic and magnetic support as an Excel file.

H. Tail gases flow, tail gases pressure, tail gases temperature

- the measuring point is located on the expansion turbine outlet pipe towards the discharge nozzle; Pytot type sensor with multiple holes; operating conditions: absolute $p = 2.5 \text{ bar}$, $t = 80^\circ\text{C}$
- pneumatic connection line (12 mm diameter and approx. 1 m long hoses) between the sensor and the electric switch box where the Dp cell is located; pneumatic connection line (6 mm diameter and approx. 2 m long hose) between the sensor and the electric switch box where the absolute pressure measuring cell is located



- measuring device: Dp differential transducer, produced by ABB, measuring range between 0 – 30 mbar; absolute pressure transducer produced by Endress&Hauser, measuring range between 0 – 0.3 bar; Pt100 thermal resistance with built-in adapter, measuring range between 0 - 200°C; analogue output signal 4 – 20 mA
- signal transmission: electric wires, approx. 5 m long, analogue signal 4 – 20 mA
- signal conversion device: ISU 24M digital indicator; placed inside the control panel; converts the analogue signal into digital signal; recording period: 2 seconds.
- data recorded into the “data logger” are transmitted through an optic fiber network to a computer designated particularly for this type of monitoring. This computer is located in the Instrumentation Plant. Data are stored in a database on the computer’s hard disk. From this database data are afterwards processed in order to obtain all data necessary for the project. The entire database is periodically saved on graphic and magnetic support as an Excel file.

I. Oxidation reactor pressure

- the measuring point is located on the air compressor discharge pipe; sensor type: capsule for electronic transducer; operating conditions: absolute $p = 3.5$ bar, $t = 200^{\circ}\text{C}$
- pneumatic connection line between the sensor and the transducer; pneumatic connection line of 8 mm diameter and approx. 10 m long
- measuring device: Foxboro transducer, measuring range between 0 – 5 bar; absolute pressure transducer produced by Endress&Hauser, measuring range between 0 – 0.3 bar; Pt100 thermal resistance with built-in adapter, measuring range between 0 - 200°C; analogue output signal 4 – 20 mA
- signal transmission: electric wires, approx. 50 m long, analogue signal 4 – 20 mA
- signal conversion device: ISU 24M digital indicator; placed inside the control panel; converts the analogue signal into digital signal; recording period: 2 seconds.
- data recorded into the “data logger” are transmitted through an optic fiber network to a computer designated particularly for this type of monitoring. This computer is located in the Instrumentation Plant. Data are stored in a database on the computer’s hard disk. From this database data are afterwards processed in order to obtain all data necessary for the project. The entire database is periodically saved on graphic and magnetic support as an Excel file.

J. N₂O concentration

- the impulse line is the same as the NO_x outlet line
- the circuit is the same as for measuring NO_x outlet concentration, including up to the pressure reducing valve outlet.



- the gas for the N₂O analyzer is taken from here through a water discharge cooler. The analyzer is produced by Environement S.A., France and is based on non-dispersive infrared absorption principle; it is placed in the same cabinet as the NO_x analyzer. The N₂O concentration measurement range is between 0 – 2000 ppm.
- the outlet analyzer signal is of 4 – 20 mA, proportional to the value of the concentration. This signal is transmitted through an electric cable at the plant's central control panel. The electric cable is approx. 100 m long.
- the device that converts the 4 – 20 mA signal in nitrogen oxides concentration is a ISU – MMC- 24C digital indicator produced by Infostar Pascani. The device has 16 inlet circuits of 4 – 20 mA. The readings are digitally displayed and are recorded every 2 seconds. Data recorded into the “data logger” are transmitted through an optic fiber network to a computer designated particularly for this type of monitoring. This computer is located in the Instrumentation Plant. Data are stored in a database on the computer's hard disk. From this database data are afterwards processed in order to obtain all data necessary for the project. The entire database is periodically saved on graphic and magnetic support as an Excel file.

MONITORING SYSTEM DESCRIPTION NITRIC ACID 3 PLANT

A. Main air flow

- the measuring point is located on the compressor air discharge pipe
- diaphragm type sensor with ring-like chambers
- operating conditions: p = 2.5 – 3 bars, t = 150°C
- pneumatic signal transmission between the sensor and the transducer through 2 impulse pipes, approx. 10 m long
- measuring device: Fischer Roesmount differential electronic transducer, having a measuring range between 0 – 45.24 mbar; output signal: analogue 4 – 20 mA
- signal transmission: electric wires, approx. 30 m long, analogue signal 4 – 20 mA
- signal conversion device: ISU 24M digital indicator; placed inside the control panel; converts the analogue signal into digital signal; recording period: 2 seconds.
- data recorded into the “data logger” are transmitted through an optic fiber network to a computer designated particularly for this type of monitoring. This computer is located in the Instrumentation Plant. Data are stored in a database on the computer's hard disk. From this database data are afterwards processed in order to obtain all data necessary for the project. The entire database is periodically saved on graphic and magnetic support as an Excel file.

B. Secondary air flow



- the measuring point is located on the air compressor discharge pipe
- diaphragm type sensor with ring-like chambers
- operating conditions: $p = 2.5 - 3$ bars, $t = 150^{\circ}\text{C}$
- pneumatic signal transmission between the sensor and the transducer through 2 impulse pipes, approx. 15 m long
- measuring device: Fischer Roesmount differential electronic transducer, having a measuring range between 0 – 500 mm H₂O; output signal: analogue 4 – 20 mA
- signal transmission: electric wires, approx. 50 m long, analogue signal 4 – 20 mA
- signal conversion device: ISU 24M digital indicator; placed inside the control panel; converts the analogue signal into digital signal; recording period: 2 seconds.
- data recorded into the “data logger” are transmitted through an optic fiber network to a computer designated particularly for this type of monitoring. This computer is located in the Instrumentation Plant. Data are stored in a database on the computer’s hard disk. From this database data are afterwards processed in order to obtain all data necessary for the project. The entire database is periodically saved on graphic and magnetic support as an Excel file.

C. Casing protection air flow

- the measuring point is located on the air duct to the reactors casing, ramifications from the compressor discharge pipe
- diaphragm type sensor with ring-like chambers
- operating conditions: $p = 2.5 - 3$ bars, $t = 150^{\circ}\text{C}$
- pneumatic signal transmission between the sensor and the transducer through 2 impulse pipes, approx. 10 m long
- measuring device: FEPA Birlad differential electronic transducer, having a measuring range between 0 – 1500 mm H₂O; output signal: analogue 4 – 20 mA
- signal transmission: electric wires, approx. 60 m long, analogue signal 4 – 20 mA
- signal conversion device: ISU 24M digital indicator; placed inside the control panel; converts the analogue signal into digital signal; recording period: 2 seconds.
- data recorded into the “data logger” are transmitted through an optic fiber network to a computer designated particularly for this type of monitoring. This computer is located in the Instrumentation Plant. Data are stored in a database on the computer’s hard disk. From this database data are afterwards processed in order to obtain all data necessary for the project. The entire database is periodically saved on graphic and magnetic support as an Excel file.

**D. Reactor sieves temperature**

- the measuring point is located on the oxidation reactor; sensor; PtRh-Pt thermocouple, operating conditions: $t = 800 - 1000^{\circ}\text{C}$
- electric signal transmission between the sensor and the transducer: PtRh-Pt correction cable, approx. 50 m long
- digital indicator measuring device; measuring range between $0 - 1000^{\circ}\text{C}$; analogue output signal $4 - 20 \text{ mA}$
- signal transmission: electric wires, approx. 6 m long, analogue signal $4 - 20 \text{ mA}$
- signal conversion device: ISU 24M digital indicator; placed inside the control panel; converts the analogue signal into digital signal; recording period: 2 seconds.
- data recorded into the “data logger” are transmitted through an optic fiber network to a computer designated particularly for this type of monitoring. This computer is located in the Instrumentation Plant. Data are stored in a database on the computer’s hard disk. From this database data are afterwards processed in order to obtain all data necessary for the project. The entire database is periodically saved on graphic and magnetic support as an Excel file.

E. Consumed liquid ammonia flow

- the measuring point is located on the ammonia evaporator inlet pipe; Coriolis type sensor; operating conditions: $p = 12 \text{ bar}$, $t = 8 - 10^{\circ}\text{C}$
- electric signal transmission between the sensor and the transducer: 2-wire cable, approx. 90 m long
- measuring device: DZL363 flowmeter adapter produced by Endress&Hauser; measuring range between $0 - 20 \text{ t/h}$; analogue output signal $4 - 20 \text{ mA}$
- signal transmission: electric wires, approx. 10 m long, analogue signal $4 - 20 \text{ mA}$
- signal conversion device: ISU 24M digital indicator; placed inside the control panel; converts the analogue signal into digital signal; recording period: 2 seconds.
- data recorded into the “data logger” are transmitted through an optic fiber network to a computer designated particularly for this type of monitoring. This computer is located in the Instrumentation Plant. Data are stored in a database on the computer’s hard disk. From this database data are afterwards processed in order to obtain all data necessary for the project. The entire database is periodically saved on graphic and magnetic support as an Excel file.

F. Flow of produced nitric acid

- the measuring point is located on the column 4 outlet pipe towards the nitric acid storehouse; electromagnetic sensor; operating conditions: $p = 2.5 \text{ bar}$, $t = 40^{\circ}\text{C}$
- electric signal transmission between the sensor and the transducer: 2-wire cable, approx. 100 m long



- measuring device: DZL363 flowmeter adapter produced by Endress&Hauser; measuring range between 0 – 100 t/h; analogue output signal 4 – 20 mA
- signal transmission: electric wires, approx. 5 m long, analogue signal 4 – 20 mA
- signal conversion device: ISU 24M digital indicator; placed inside the control panel; converts the analogue signal into digital signal; recording period: 2 seconds.
- data recorded into the “data logger” are transmitted through an optic fiber network to a computer designated particularly for this type of monitoring. This computer is located in the Instrumentation Plant. Data are stored in a database on the computer’s hard disk. From this database data are afterwards processed in order to obtain all data necessary for the project. The entire database is periodically saved on graphic and magnetic support as an Excel file.

G. Temperature of produced nitric acid

- the measuring point is located on the column 4 outlet pipe towards the nitric acid storehouse; Coriolis type sensor; operating conditions: $p = 2.5 \text{ bar}$, $t = 40^\circ\text{C}$
- electric signal transmission between the sensor and the transducer: 2-wire cable, approx. 100 m long
- measuring device: DZL363 flowmeter adapter produced by Endress&Hauser; measuring range between $-50 - 200^\circ\text{C}$; analogue output signal 4 – 20 mA
- signal transmission: electric wires, approx. 5 m long, analogue signal 4 – 20 mA
- signal conversion device: ISU 24M digital indicator; placed inside the control panel; converts the analogue signal into digital signal; recording period: 2 seconds.
- data recorded into the “data logger” are transmitted through an optic fiber network to a computer designated particularly for this type of monitoring. This computer is located in the Instrumentation Plant. Data are stored in a database on the computer’s hard disk. From this database data are afterwards processed in order to obtain all data necessary for the project. The entire database is periodically saved on graphic and magnetic support as an Excel file.

H. Density of produced nitric acid

- the measuring point is located on the column 4 outlet pipe towards the nitric acid storehouse; Coriolis type sensor; operating conditions: $p = 2.5 \text{ bar}$, $t = 40^\circ\text{C}$
- electric signal transmission between the sensor and the transducer: 2-wire cable, approx. 100 m long



- measuring device: DZL363 flowmeter adapter produced by Endress&Hauser; measuring range between 1.2 – 1.4 kg/l; analogue output signal 4 – 20 mA
- signal transmission: electric wires, approx. 5 m long, analogue signal 4 – 20 mA
- signal conversion device: ISU 24M digital indicator; placed inside the control panel; converts the analogue signal into digital signal; recording period: 2 seconds.
- data recorded into the “data logger” are transmitted through an optic fiber network to a computer designated particularly for this type of monitoring. This computer is located in the Instrumentation Plant. Data are stored in a database on the computer’s hard disk. From this database data are afterwards processed in order to obtain all data necessary for the project. The entire database is periodically saved on graphic and magnetic support as an Excel file.

I. Tail gases flow, tail gases pressure, tail gases temperature

- the measuring point is located on the expansion turbine outlet pipe towards the discharge nozzle; Pytot type sensor with multiple holes; operating conditions: absolute $p = 2.5$ bar, $t = 80^{\circ}\text{C}$
- pneumatic connection line (12 mm diameter and approx. 1 m long hoses) between the sensor and the electric switch box where the Dp cell is located; pneumatic connection line (6 mm diameter and approx. 2 m long hose) between the sensor and the electric switch box where the absolute pressure measuring cell is located
- measuring device: Dp differential transducer, produced by ABB, measuring range between 0 – 30 mbar; absolute pressure transducer produced by Endress&Hauser, measuring range between 0 – 0.3 bar; Pt100 thermal resistance with built-in adapter, measuring range between 0 - 200°C ; analogue output signal 4 – 20 mA
- signal transmission: electric wires, approx. 5 m long, analogue signal 4 – 20 mA
- signal conversion device: ISU 24M digital indicator; placed inside the control panel; converts the analogue signal into digital signal; recording period: 2 seconds.
- data recorded into the “data logger” are transmitted through an optic fiber network to a computer designated particularly for this type of monitoring. This computer is located in the Instrumentation Plant. Data are stored in a database on the computer’s hard disk. From this database data are afterwards processed in order to obtain all data necessary for the project. The entire database is periodically saved on graphic and magnetic support as an Excel file.

J. Oxidation reactor pressure



- the measuring point is located on the air compressor discharge pipe; sensor type: capsule for electronic transducer; operating conditions: absolute $p = 3.5$ bar, $t = 200^{\circ}\text{C}$
- pneumatic connection line between the sensor and the transducer; pneumatic connection line of 8 mm diameter and approx. 10 m long
- measuring device: Foxboro transducer, measuring range between 0 – 5 bar; absolute pressure transducer produced by Endress&Hauser, measuring range between 0 – 0.3 bar; Pt100 thermal resistance with built-in adapter, measuring range between 0 - 200°C ; analogue output signal 4 – 20 mA
- signal transmission: electric wires, approx. 50 m long, analogue signal 4 – 20 mA
- signal conversion device: ISU 24M digital indicator; placed inside the control panel; converts the analogue signal into digital signal; recording period: 2 seconds.
- data recorded into the “data logger” are transmitted through an optic fiber network to a computer designated particularly for this type of monitoring. This computer is located in the Instrumentation Plant. Data are stored in a database on the computer’s hard disk. From this database data are afterwards processed in order to obtain all data necessary for the project. The entire database is periodically saved on graphic and magnetic support as an Excel file.

K. N_2O concentration

- the impulse line is the same as the NO_x outlet line
- the circuit is the same as for measuring NO_x outlet concentration, including up to the pressure reducing valve outlet.
- the gas for the N_2O analyzer is taken from here through a water discharge cooler. The analyzer is produced by Environement S.A., France and is based on non-dispersive infrared absorption principle; it is placed in the same cabinet as the NO_x analyzer. The N_2O concentration measurement range is between 0 – 2000 ppm.
- the outlet analyzer signal is of 4 – 20 mA, proportional to the value of the concentration. This signal is transmitted through an electric cable at the plant’s central control panel. The electric cable is approx. 100 m long.
- the device that converts the 4 – 20 mA signal in nitrogen oxides concentration is a ISU – MMC- 24C digital indicator produced by Infostar Pascani. The device has 16 inlet circuits of 4 – 20 mA. The readings are digitally displayed and are recorded every 2 seconds. Data recorded into the “data logger” are transmitted through an optic fiber network to a computer designated particularly for this type of monitoring. This computer is located in the Instrumentation Plant. Data are stored in a database on the computer’s hard disk. From this database data are afterwards processed in order to obtain all data necessary for the project. The entire database is periodically saved on graphic and magnetic support as an Excel file.



MONITORING SYSTEM DESCRIPTION NITRIC ACID 4 PLANT

A. Main air flow

- the measuring point is located on the compressor air discharge pipe
- diaphragm type sensor with ring-like chambers
- operating conditions: $p = 2.5 - 3$ bars, $t = 150^{\circ}\text{C}$
- pneumatic signal transmission between the sensor and the transducer through 2 impulse pipes, approx. 10 m long
- measuring device: Fischer Roesmount differential electronic transducer, having a measuring range between 0 – 45.24 mbar; output signal: analogue 4 – 20 mA
- signal transmission: electric wires, approx. 30 m long, analogue signal 4 – 20 mA
- signal conversion device: ISU 24M digital indicator; placed inside the control panel; converts the analogue signal into digital signal; recording period: 2 seconds.
- data recorded into the “data logger” are transmitted through an optic fiber network to a computer designated particularly for this type of monitoring. This computer is located in the Instrumentation Plant. Data are stored in a database on the computer’s hard disk. From this database data are afterwards processed in order to obtain all data necessary for the project. The entire database is periodically saved on graphic and magnetic support as an Excel file.

B. Secondary air flow

- the measuring point is located on the air compressor discharge pipe
- diaphragm type sensor with ring-like chambers
- operating conditions: $p = 2.5 - 3$ bars, $t = 150^{\circ}\text{C}$
- pneumatic signal transmission between the sensor and the transducer through 2 impulse pipes, approx. 15 m long
- measuring device: Fischer Roesmount differential electronic transducer, having a measuring range between 0 – 500 mm H₂O; output signal: analogue 4 – 20 mA
- signal transmission: electric wires, approx. 50 m long, analogue signal 4 – 20 mA
- signal conversion device: ISU 24M digital indicator; placed inside the control panel; converts the analogue signal into digital signal; recording period: 2 seconds.
- data recorded into the “data logger” are transmitted through an optic fiber network to a computer designated particularly for this type of monitoring. This computer is located in the Instrumentation Plant. Data are stored in a database on the computer’s hard disk. From this



database data are afterwards processed in order to obtain all data necessary for the project. The entire database is periodically saved on graphic and magnetic support as an Excel file.

C. Reactor sieves temperature

- the measuring point is located on the oxidation reactor; sensor; PtRh-Pt thermocouple, operating conditions: $t = 800 - 1000^{\circ}\text{C}$
- electric signal transmission between the sensor and the transducer: PtRh-Pt correction cable, approx. 50 m long
- digital indicator measuring device; measuring range between $0 - 1000^{\circ}\text{C}$; analogue output signal $4 - 20 \text{ mA}$
- signal transmission: electric wires, approx. 6 m long, analogue signal $4 - 20 \text{ mA}$
- signal conversion device: ISU 24M digital indicator; placed inside the control panel; converts the analogue signal into digital signal; recording period: 2 seconds.
- data recorded into the “data logger” are transmitted through an optic fiber network to a computer designated particularly for this type of monitoring. This computer is located in the Instrumentation Plant. Data are stored in a database on the computer’s hard disk. From this database data are afterwards processed in order to obtain all data necessary for the project. The entire database is periodically saved on graphic and magnetic support as an Excel file.

D. Consumed liquid ammonia flow

- the measuring point is located on the ammonia evaporator inlet pipe; Coriolis type sensor; operating conditions: $p = 12 \text{ bar}$, $t = 8 - 10^{\circ}\text{C}$
- electric signal transmission between the sensor and the transducer: 2-wire cable, approx. 90 m long
- measuring device: DZL363 flowmeter adapter produced by Endress&Hauser; measuring range between $0 - 20 \text{ t/h}$; analogue output signal $4 - 20 \text{ mA}$
- signal transmission: electric wires, approx. 10 m long, analogue signal $4 - 20 \text{ mA}$
- signal conversion device: ISU 24M digital indicator; placed inside the control panel; converts the analogue signal into digital signal; recording period: 2 seconds.
- data recorded into the “data logger” are transmitted through an optic fiber network to a computer designated particularly for this type of monitoring. This computer is located in the Instrumentation Plant. Data are stored in a database on the computer’s hard disk. From this database data are afterwards processed in order to obtain all data necessary for the project. The entire database is periodically saved on graphic and magnetic support as an Excel file.

E. Flow of produced nitric acid



- the measuring point is located on the column 4 outlet pipe towards the nitric acid storehouse; electromagnetic sensor; operating conditions: $p = 2.5 \text{ bar}$, $t = 40^\circ\text{C}$
- electric signal transmission between the sensor and the transducer: 2-wire cable, approx. 100 m long
- measuring device: DZL363 flowmeter adapter produced by Endress&Hauser; measuring range between 0 – 100 t/h; analogue output signal 4 – 20 mA
- signal transmission: electric wires, approx. 5 m long, analogue signal 4 – 20 mA
- signal conversion device: ISU 24M digital indicator; placed inside the control panel; converts the analogue signal into digital signal; recording period: 2 seconds.
- data recorded into the “data logger” are transmitted through an optic fiber network to a computer designated particularly for this type of monitoring. This computer is located in the Instrumentation Plant. Data are stored in a database on the computer’s hard disk. From this database data are afterwards processed in order to obtain all data necessary for the project. The entire database is periodically saved on graphic and magnetic support as an Excel file.

F. Temperature of produced nitric acid

- the measuring point is located on the column 4 outlet pipe towards the nitric acid storehouse; Coriolis type sensor; operating conditions: $p = 2.5 \text{ bar}$, $t = 40^\circ\text{C}$
- electric signal transmission between the sensor and the transducer: 2-wire cable, approx. 100 m long
- measuring device: DZL363 flowmeter adapter produced by Endress&Hauser; measuring range between $-50 - 200^\circ\text{C}$; analogue output signal 4 – 20 mA
- signal transmission: electric wires, approx. 5 m long, analogue signal 4 – 20 mA
- signal conversion device: ISU 24M digital indicator; placed inside the control panel; converts the analogue signal into digital signal; recording period: 2 seconds.
- data recorded into the “data logger” are transmitted through an optic fiber network to a computer designated particularly for this type of monitoring. This computer is located in the Instrumentation Plant. Data are stored in a database on the computer’s hard disk. From this database data are afterwards processed in order to obtain all data necessary for the project. The entire database is periodically saved on graphic and magnetic support as an Excel file.

G. Density of produced nitric acid



- the measuring point is located on the column 4 outlet pipe towards the nitric acid storehouse; Coriolis type sensor; operating conditions: $p = 2.5 \text{ bar}$, $t = 40^\circ\text{C}$
- electric signal transmission between the sensor and the transducer: 2-wire cable, approx. 100 m long
- measuring device: DZL363 flowmeter adapter produced by Endress&Hauser; measuring range between 1.2 – 1.4 kg/l; analogue output signal 4 – 20 mA
- signal transmission: electric wires, approx. 5 m long, analogue signal 4 – 20 mA
- signal conversion device: ISU 24M digital indicator; placed inside the control panel; converts the analogue signal into digital signal; recording period: 2 seconds.
- data recorded into the “data logger” are transmitted through an optic fiber network to a computer designated particularly for this type of monitoring. This computer is located in the Instrumentation Plant. Data are stored in a database on the computer’s hard disk. From this database data are afterwards processed in order to obtain all data necessary for the project. The entire database is periodically saved on graphic and magnetic support as an Excel file.

H. Tail gases flow, tail gases pressure, tail gases temperature

- the measuring point is located on the expansion turbine outlet pipe towards the discharge nozzle; Pytot type sensor with multiple holes; operating conditions: absolute $p = 2.5 \text{ bar}$, $t = 80^\circ\text{C}$
- pneumatic connection line (12 mm diameter and approx. 1 m long hoses) between the sensor and the electric switch box where the Dp cell is located; pneumatic connection line (6 mm diameter and approx. 2 m long hose) between the sensor and the electric switch box where the absolute pressure measuring cell is located
- measuring device: Dp differential transducer, produced by ABB, measuring range between 0 – 30 mbar; absolute pressure transducer produced by Endress&Hauser, measuring range between 0 – 0.3 bar; Pt100 thermal resistance with built-in adapter, measuring range between 0 - 200°C; analogue output signal 4 – 20 mA
- signal transmission: electric wires, approx. 5 m long, analogue signal 4 – 20 mA
- signal conversion device: ISU 24M digital indicator; placed inside the control panel; converts the analogue signal into digital signal; recording period: 2 seconds.
- data recorded into the “data logger” are transmitted through an optic fiber network to a computer designated particularly for this type of monitoring. This computer is located in the Instrumentation Plant. Data are stored in a database on the computer’s hard disk. From this database data are afterwards processed in order to obtain all data necessary for the project. The entire database is periodically saved on graphic and magnetic support as an Excel file.



I. Oxidation reactor pressure

- the measuring point is located on the air compressor discharge pipe; sensor type: capsule for electronic transducer; operating conditions: absolute $p = 3.5$ bar, $t = 200^{\circ}\text{C}$
- pneumatic connection line between the sensor and the transducer; pneumatic connection line of 8 mm diameter and approx. 10 m long
- measuring device: Foxboro transducer, measuring range between 0 – 5 bar; absolute pressure transducer produced by Endress&Hauser, measuring range between 0 – 0.3 bar; Pt100 thermal resistance with built-in adapter, measuring range between 0 - 200°C ; analogue output signal 4 – 20 mA
- signal transmission: electric wires, approx. 50 m long, analogue signal 4 – 20 mA
- signal conversion device: ISU 24M digital indicator; placed inside the control panel; converts the analogue signal into digital signal; recording period: 2 seconds.
- data recorded into the “data logger” are transmitted through an optic fiber network to a computer designated particularly for this type of monitoring. This computer is located in the Instrumentation Plant. Data are stored in a database on the computer’s hard disk. From this database data are afterwards processed in order to obtain all data necessary for the project. The entire database is periodically saved on graphic and magnetic support as an Excel file.

J. N₂O concentration

- the impulse line is the same as the NO_x outlet line
- the circuit is the same as for measuring NO_x outlet concentration, including up to the pressure reducing valve outlet.
- the gas for the N₂O analyzer is taken from here through a water discharge cooler. The analyzer is produced by Environement S.A., France and is based on non-dispersive infrared absorption principle; it is placed in the same cabinet as the NO_x analyzer. The N₂O concentration measurement range is between 0 – 2000 ppm.
- the outlet analyzer signal is of 4 – 20 mA, proportional to the value of the concentration. This signal is transmitted through an electric cable at the plant’s central control panel. The electric cable is approx. 100 m long.
- the device that converts the 4 – 20 mA signal in nitrogen oxides concentration is a ISU – MMC- 24C digital indicator produced by Infostar Pascani. The device has 16 inlet circuits of 4 – 20 mA. The readings are digitally displayed and are recorded every 2 seconds. Data recorded into the “data logger” are transmitted through an optic fiber network to a computer designated particularly for this type of monitoring. This computer is located in the Instrumentation Plant. Data are stored in a database on the computer’s hard disk. From this database data are



afterwards processed in order to obtain all data necessary for the project. The entire database is periodically saved on graphic and magnetic support as an Excel file.

D.1.1. Option 1 – Monitoring of the emissions in the project scenario and the baseline scenario:

| D.1.1.1. Data to be collected in order to monitor emissions from the project, and how these data will be archived: | | | | | | | | |
|--|---|--|--|---|-------------------------------------|------------------------------------|--|---------|
| ID number (Please use numbers to ease cross-referencing to D.2.) | Data variable | Source of data | Data unit | Measured (m), calculated (c), estimated (e) | Recording frequency | Proportion of data to be monitored | How will the data be archived? (electronic/ paper) | Comment |
| P.1 | NC _{SG} _{2,3,4} N ₂ O concentration in the stack gas for particular plant | N ₂ O analyser MIR9000 | mgN ₂ O/m ³ (converted from ppmV) | m | Every 2 seconds | 100% | Electronic and paper for at least 2 years | |
| P.2 | VSG _{2,3,4} Volume flow rate of the stack gas for particular plant | Gas volume flow meter ABB | m ³ /h | m | Every 2 seconds | 100% | Electronic and paper for at least 2 years | |
| P.3 | PE _{n, 2,3,4} N ₂ O emissions of n th project campaign for particular | Calculation from measured data | tN ₂ O | c | After every project campaign | 100% | Electronic and paper for at least 2 years | |
| P.4 | OH _{2,3,4} Operating hours for particular line | Monitoring system | Hours | m | Daily, compiled for entire campaign | 100% | Paper for entire crediting period | |



| | | | | | | | | |
|------|--|--|-------------------------------------|---|-------------------------------------|------|---|---|
| | (l=A, B) | | | | | | | |
| P.5 | NAP _{2,3,4} Nitric acid production (100% concentrate) for particular line (l=A, B) | Monitoring system | tHNO ₃ | m | Daily, compiled for entire campaign | 100% | Electronic and paper for at least 2 years | |
| P.6 | TSG _{2,3,4} Temperature of stack gas for particular line (l=A, B) | Thermocouple sensor | °C | m | Every 2 seconds | 100% | Electronic and paper for at least 2 years | |
| P.7 | PSG _{2,3,4} Pressure of stack gas for particular line (l=A, B) | Foxboro transducer | | m | Every 2 seconds | 100% | Electronic and paper for at least 2 years | |
| P.8 | EF _{n, 2,3,4} Emission factor calculated for n th campaign for particular line (l=A, B) | Calculated from measured data | tN ₂ O/tHNO ₃ | c | After end of each campaign | | | |
| P.9 | EF _{mn,a, 2,3,4} Moving average emissions factor for particular line (l=A, B) | Calculated from campaign emissions factors | tN ₂ O/tHNO ₃ | c | After end of each campaign | | | For the first campaign EF and EF _x will be equal |
| P.12 | CL _{n, 2,3,4} | Calculated from | tHNO ₃ | c | After end of | 100% | Electronic and | |



| | | | | | | | | |
|------|--|--|-------------------------------------|---|--|--|----------------------------|--|
| | Campaign length for particular line (l=A, B) | nitric acid production data | | | each campaign | | paper for at least 2 years | |
| P.13 | EF _{p, 2,3,4} Emissions factor used to determine emissions reductions for particular line (l=A, B) | Determined from campaign emissions factors | tN ₂ O/tHNO ₃ | c | After end of each campaign | | | Determined from campaign emissions factors |
| P.14 | EF _{min, 2,3,4} Minimum emissions factor after 10 campaigns for particular line (l=A, B) | Determined from campaign emissions factors | tN ₂ O/tHNO ₃ | c | After end of 10 th campaign | | | Determined from campaign emissions factors |

D.1.1.2. Description of formulae used to estimate project emissions (for each gas, source etc.; emissions in units of CO₂ equivalent):

Over the duration of the project activity, N₂O concentration and gas volume flow in the stack of the nitric acid plant as well as the temperature and pressure of ammonia gas flow and ammonia-to-air ratio on all 3 nitric acid plants have been measured continuously.

Estimation of campaign-specific project emissions

The monitoring system was installed using the guidance document EN 14181 and provides separate readings for N₂O concentration and gas flow volume for every hour of operation. Error readings (e.g. downtime or malfunction) and extreme values are automatically eliminated from the output data series by the monitoring system. Same statistical evaluation that was applied to the baseline data series will be applied to the project data series:

- a) Calculate the sample mean (x)
- b) Calculate the sample standard deviation (s)



- c) Calculate the 95% confidence interval (equal to 1.96 times the standard deviation)
- d) Eliminate all data that lie outside the 95% confidence interval
- e) Calculate the new sample mean from the remaining values

$$PE_n = VSG * NCSG * 10^{-9} * OH \text{ (tN}_2\text{O)}$$

where::

| Variable | Definition |
|-----------------|---|
| VSG | Mean stack gas volume flow rate for the project campaign (m ³ /h) |
| NCSG | Mean concentration of N ₂ O in the stack gas for the project campaign (mgN ₂ O/m ³) |
| PE _n | Total N ₂ O emissions of the n th project campaign (tN ₂ O) |
| OH | Is the number of hours of operation in the specific monitoring period (h) |

Derivation of a moving average emission factor

In order to take into account possible long-term emissions trends over the duration of the project activity and to take a conservative approach a moving average emission factor will be estimated as follows:

Step 1: campaign specific emissions factor for each campaign during the project's crediting period will be estimated by dividing the total mass of N₂O emissions during that campaign by the total production of 100% concentrated nitric acid during that same campaign.

For example, for campaign n the campaign specific emission factor would be:

$$EF_n = PE_n / NAP_n \text{ (tN}_2\text{O/tHNO}_3\text{)}$$

Step 2: moving average emissions factor to be calculated at the end of a campaign n will be estimated as follows:

$$EF_{ma,n} = (EF_1 + EF_2 + \dots + EF_n) / n \text{ (tN}_2\text{O/tHNO}_3\text{)}$$

This process will be repeated for each campaign such that a moving average, EF_{ma,n}, will be established over time, becoming more representative and precise with each additional campaign.



To calculate the total emission reductions achieved in a campaign in formula below, the higher of the two values $EF_{ma,n}$ and EF_n shall be applied as the emission factor relevant for the particular campaign to be used to calculate emissions reduction s (EF_p). Thus:

If $EF_{ma,n} > EF_n$ then $EF_p = EF_{ma,n}$

If $EF_{ma,n} < EF_n$ then $EF_p = EF_n$

Where:

| Variable | Definition |
|-------------|--|
| EF_n | Emission factor calculated for a specific project campaign ($tN_2O/tHNO_3$) |
| $EF_{ma,n}$ | Moving average (ma) emission factor of after n^{th} campaigns, including the current campaign ($tN_2O/tHNO_3$) |
| n | Number of campaigns to date |
| EF_p | Emissions factor that will be applied to calculate the emissions reductions from this specific campaign (i.e. the higher of EF_x and EF_n) ($tN_2O/tHNO_3$) |

Minimum project emission factor

A campaign-specific emissions factor will be used to cap any potential long-term trend towards decreasing N_2O emissions that may result from a potential built up of platinum deposits. After the first ten campaigns of the crediting period of the project, the lowest EF_n observed during those campaigns will be adopted as a minimum (EF_{min}). If any of the later project campaigns results in a EF_n that is lower than EF_{min} , the calculation of the emission reductions for that particular campaign will use EF_{min} and not EF_n .

Where:

| Variable | Definition |
|------------|--|
| EF_{min} | Is equal to the lowest EF_n observed during the first 10 campaigns of the project crediting period ($N_2O/tHNO_3$) |

Project Campaign Length

a. Longer Project Campaign

If the length of each individual project campaign CL_n is longer than or equal to the average historic campaign length CL_{normal} , then all N_2O values measured during the baseline campaign can be used for the calculation of EF .

b. Shorter Project Campaign



In practice this means that, if the assumption that platinum deposits do have a reducing effect on N₂O emissions is correct, then an increasing adoption of EF_{min} instead of EF_n should be experienced as the project progresses through its crediting period.

If $CL_n < CL_{normal}$, EF_{BL} will be recalculated by eliminating those N₂O values that were obtained during the production of tonnes of nitric acid beyond the CL_n (i.e. the last tonnes produced) from the calculation of EF_n.

Leakage

No leakage calculation is required.

| D.1.1.3. Relevant data necessary for determining the <u>baseline</u> of anthropogenic emissions of greenhouse gases by sources within the project boundary, and how such data will be collected and archived: | | | | | | | | |
|--|---|--|--|---|---------------------|------------------------------------|--|---------|
| ID number (Please use numbers to ease cross-referencing to D.2.) | Data variable | Source of data | Data unit | Measured (m), calculated (c), estimated (e) | Recording frequency | Proportion of data to be monitored | How will the data be archived? (electronic/ paper) | Comment |
| B.1 | NCSG _{BC, 2,3,4} N ₂ O concentration in the stack gas for particular plant | N ₂ O analyser MIR9000 | mgN ₂ O/m ³ (converted from ppmV) | m | Every 2 seconds | 100% | Electronic and paper for the entire crediting period | |
| B.2 | VSG _{BC, 2,3,4} Volume flow rate of the stack gas for particular plant | Gas volume flow meter ABB | m ³ /h | m | Every 2 seconds | 100% | Electronic and paper for the entire crediting period | |



| | | | | | | | | |
|-----|---|--------------------------------|-------------------------------------|---|---------------------------------------|------|--|--|
| B.3 | BE _{BC, 2,3,4} Total N ₂ O for baseline campaign for particular plant | Calculation from measured data | tN ₂ O | c | At least once after baseline campaign | 100% | Electronic and paper for the entire crediting period | |
| B.4 | OH _{BC, 2,3,4} Operating hours for particular plant | Monitoring system | Hours | m | Daily, compiled for entire campaign | 100% | Electronic and paper for the entire crediting period | |
| B.5 | NAP _{BC, 2,3,4} Nitric acid (100% concentrated) over baseline campaign for particular plant | Monitoring system | tHNO ₃ | m | Daily, compiled for entire campaign | 100% | Electronic and paper for the entire crediting period | |
| B.6 | TSG _{2,3,4} Temperature of stack gas for particular plant | Thermocouple sensor | °C | m | Every 2 seconds | 100% | Electronic and paper for the entire crediting period | |
| B.7 | PSG _{2,3,4} Pressure of stack gas for particular plant | Foxboro transducer | hPa | m | Every 2 seconds | 100% | Electronic and paper for the entire crediting period | |
| B.8 | EF _{BL, 2,3,4} Emission factor for baseline period for particular plant | Calculated from measured data | tN ₂ O/tHNO ₃ | c | At the end of the baseline campaign | | Electronic and paper for the entire crediting period | |



| | | | | | | | | |
|------|--|---|----------------------|----|--|------|--|--|
| B.9 | UNC _{2,3,4} Overall measurement uncertainty of the monitoring system | Calculation of the combined uncertainty of the applied monitoring equipment | % | c | Once after monitoring system is commissioned | | Electronic and paper for the duration of the project | |
| B.10 | AFR _{2,3,4} Ammonia gas flow rate to the AOR for particular plant | Monitored | kgNH ₃ /h | m | Continuously | 100% | Electronic and paper for at least 2 years | |
| B.11 | AFR _{max, 2,3,4} Maximum ammonia flow rate for particular plant | Plant records | kgNH ₃ /h | m | Once | 100% | Electronic and paper for at least 2 years | |
| B.12 | AIFR _{2,3,4} Ammonia to Air ratio for particular plant | Monitored | % | mc | Every hour | 100% | Electronic and paper for at least 2 years | |
| B.13 | CL _{BL, 2,3,4} Campaign length of baseline campaign for particular plant | Calculated from nitric acid production data | tHNO ₃ | c | After end of each campaign | 100% | Electronic and paper for at least 2 years | |
| B.14 | CL _{normal, 2,3,4} Normal campaign length for particular plant | Calculated from nitric acid production data | tHNO ₃ | cm | Prior to end of baseline campaign | | | |



| | | | | | | | | |
|------|--|------------|----|-----|------------|------|---|--|
| B.15 | AIFR _{max, 2,3,4} Maximum ammonia to air ratio for particular plant | Calculated | % | mcm | Once | 100% | Electronic and paper for at least 2 years | |
| B.16 | OT _{h, 2,3,4} Oxidation temperature for each hour for particular plant | Monitored | °C | m | Every hour | 100% | Electronic and paper for at least 2 years | |
| B.17 | OT _{normal, 2,3,4} Normal operating temperature for particular plant | Monitored | °C | m | Once | 100% | Electronic and paper for at least 2 years | |
| B.18 | OP _{h, 2,3,4} Oxidation pressure for each hour for particular plant | Monitored | Pa | m | Every hour | 100% | Electronic and paper for at least 2 years | |
| B.19 | OP _{normal, 2,3,4} Normal operating pressure for particular plant | Monitored | Pa | m | Once | 100% | Electronic and paper for at least 2 years | |



| | | | | | | | | |
|------|---|-----------|--|---|---------------|------|------------------------------|--|
| B.20 | GS _{normal, 2,3,4} Normal gauze supplier for the operation condition campaigns for particular plant | Monitored | | m | | 100% | For project crediting period | |
| B.21 | GS _{BL, 2,3,4} Gauze supplier for baseline campaign for particular plant | Monitored | | m | Once | 100% | For project crediting period | |
| B.22 | GS _{project, 2,3,4} Gauze supplier for the project campaigns for particular plant | Monitored | | m | Each campaign | 100% | For project crediting period | |
| B.23 | GC _{normal, 2,3,4} Gauze composition during the operation campaign for particular plant | Monitored | | m | Each campaign | 100% | For project crediting period | |
| B.24 | GC _{BL, 2,3,4} Gauze composition during baseline campaign for particular plant | Monitored | | m | Once | 100% | For project crediting period | |



| | | | | | | | | |
|------|---|-----------|--|---|---------------|------|------------------------------|--|
| B.25 | GC _{project, 2,3,4} Gauze composition during baseline campaign for particular plant | Monitored | | m | Each campaign | 100% | For project crediting period | |
| B.26 | EF _{reg} Emissions level set by incoming policies or regulations | | | | | | | |

D.1.1.4. Description of formulae used to estimate baseline emissions (for each gas, source etc.; emissions in units of CO₂ equivalent):

The baseline for both Azomures nitric acid production lines NA2, NA3 and NA4 shall be established separately through continuous monitoring of both N₂O concentration and gas flow volume in the stacks.

The schematic of the procedure is as follows:

1. Determination of the permitted operating conditions of the nitric acid plant to avoid overestimation of baseline emissions:

In order to avoid the possibility that the operating conditions of the nitric acid production plant are modified in such a way that increases N₂O generation during the baseline campaign, the normal ranges for operating conditions have been determined for the following parameters:

- (i) oxidation temperature;
- (ii) oxidation pressure;
- (iii) ammonia gas flow rate;
- (iv) air input flow rates. 68.



| | | NA2 | | NA3 | | NA4 | |
|-----------------------|-------------------|---------|---------|---------|---------|---------|---------|
| | | minimum | maximum | minimum | maximum | minimum | maximum |
| Oxidation temperature | °C | 800 | 880 | 800 | 860 | 800 | 860 |
| Oxidation pressure | bar G | 2.5 | 4.0 | 0.0 | 2.6 | 1.8 | 3.0 |
| Ammonia gas flow rate | m ³ /h | 7,800 | 12,000 | 8,000 | 12,500 | 8,000 | 13,800 |
| Air input rate | m ³ /h | 68,000 | 106,000 | 60,000 | 116,000 | 70,000 | 121,000 |

Because prior to implementation of JI project there were no requirements and no need from the plant operation point of view to store data on operating conditions, the “permitted range” for oxidation temperature and pressure has been determined, in accordance with the AM0034 methodology, using the range stipulated in the operating manual for the nitric acid production process.

ii. Ammonia gas flow rates and ammonia to air ratio input into the ammonia oxidation reactor (AOR):

Parameters monitored are the following:

| | |
|---------------------|--|
| AFR | Ammonia gas flow rate to four AORs in one line (tNH ₃ /h) |
| AFR _{max} | Maximum ammonia gas flow rate to four AORs in one line (tNH ₃ /h) |
| AIFR | Ammonia to air ratio (%) |
| AIFR _{max} | Maximum ammonia to air ratio (%) |

The upper limits for ammonia flow and ammonia to air ratio has been determined using calculation of maximum permitted ammonia gas flow rates and ammonia to air ratio as specified for typical catalyst loadings.

Permitted ranges for pressure, temperature, ammonia flow rate and ammonia to air ratio determined are within the Operating Manual for nitric acid production process.

2. Determination of baseline emission factor: measurement procedure for N₂O concentration and gas volume flow

N₂O concentration and gas volume flow are monitored on all 3 Azomures nitric acid plants NA2, NA3 and NA4 throughout the baseline campaign. The monitoring system installed complies with requirements of the European Norm 14181 (2004).

Monitoring system provides separate readings for N₂O concentration and gas flow volume for every hour of operation as an average of the measured values for the previous 60 minutes. Error readings (e.g. downtime or malfunction) and extreme values are automatically eliminated from the output data series by the monitoring system.



Measurement results can be distorted before and after periods of downtime or malfunction of the monitoring system and can lead to mavericks. To eliminate such extremes and to ensure a conservative approach, the following statistical evaluation is applied to the complete data series of N₂O concentration as well as to the data series for gas volume flow. The statistical procedure is applied to data obtained after eliminating data measured for periods where the plant operated outside the permitted ranges:

- a) Calculate the sample mean (\bar{x})
- b) Calculate the sample standard deviation (s)
- c) Calculate the 95% confidence interval (equal to 1.96 times the standard deviation)
- d) Eliminate all data that lie outside the 95% confidence interval
- e) Calculate the new sample mean from the remaining values (volume of stack gas (VSG) and N₂O concentration of stack gas (NCSG))

The average mass of N₂O emissions per hour is estimated as product of the NCSG and VSG. The N₂O emissions per campaign are estimates product of N₂O emission per hour and the total number of complete hours of operation of the campaign using the following equation:

$$BE_{BC} = VSG_{BC} * NCSG_{BC} * 10^{-9} * OH_{BC} \text{ (tN}_2\text{O)}$$

The plant specific baseline emissions factor representing the average N₂O emissions per tonne of nitric acid over one full campaign is derived by dividing the total mass of N₂O emissions by the total output of 100% concentrated nitric acid for that period. The overall uncertainty of the monitoring system shall also be determined and the measurement error will be expressed as a percentage (*UNC*). The N₂O emission factor per tonne of nitric acid produced in the baseline period (EF_{BL}) shall then be reduced by the estimated percentage error as follows:

$$EF_{BL} = (BE_{BC} / NAP_{BC}) (1 - UNC/100) \text{ (tN}_2\text{O/tHNO}_3\text{)}$$

where:

| Variable | Definition |
|-------------|---|
| EF_{BL} | Baseline N ₂ O emissions factor (tN ₂ O/tHNO ₃) |
| BE_{BC} | Total N ₂ O emissions during the baseline campaign (tN ₂ O) |
| $NCSG_{BC}$ | Mean concentration of N ₂ O in the stack gas during the baseline campaign (mgN ₂ O/m ³) |
| OH_{BC} | Operating hours of the baseline campaign (h) |
| VSG_{BC} | Mean gas volume flow rate at the stack in the baseline measurement period (m ³ /h) |
| NAP_{BC} | Nitric acid production during the baseline campaign (tHNO ₃) |



UNC Overall uncertainty of the monitoring system (%), calculated as the combined uncertainty of the applied monitoring equipment.

Since there are not in Romania any national or regional regulations for N₂O emissions, the resulting EF_{BL} is used as the baseline emission factor.

Under certain circumstances, the operating conditions during the measurement period used to determine baseline N₂O emission factor may be outside the permitted range or limit corresponding to normal operating conditions. For instance, temperature, pressure, ammonia flow rate or ammonia to air ratio may be outside the permitted condition. Any N₂O baseline data that have been measured during hours where the operating conditions are outside the permitted range are eliminated from the calculation of the baseline emissions factor.

In order to further ensure that operating conditions during the baseline campaign are representative of normal operating conditions, statistical tests will be performed to compare the average values of the permitted operating conditions with the average values obtained during the baseline measurement period.

Impact of regulations:

Should N₂O emissions regulations that apply to nitric acid plants be introduced in Romania (host country), such regulations will be compared to the calculated baseline factor for the project (EF_{BL}), regardless of whether the regulatory level is expressed as:

- An absolute cap on the total volume of N₂O emissions for a set period;
- A relative limit on N₂O emissions expressed as a quantity per unit of output; or
- A threshold value for specific N₂O mass flow in the stack;

In this case, a corresponding plant-specific emissions factor cap (max. allowed tN₂O/tHNO₃) will be derived from the regulatory level. If the regulatory limit would be lower than the baseline factor determined for the project, the regulatory limit would serve as the new baseline factor, that is:

if EF_{BL} > EF_{reg}, then the baseline N₂O emission factor shall be EF_{reg} for all calculations.

where:

| Variable | Definition |
|-------------------|---|
| EF _{BL} | Baseline emissions factor (tN ₂ O/tHNO ₃) |
| EF _{reg} | Emissions level set by newly introduced policies or regulations (tN ₂ O/tHNO ₃). |

Such EF_{reg} would be determined according to the nature of the regulation (e.g. in terms of absolute emission, by-product rate, concentration in stack gas), as described in the approved methodology AM0028.

**The composition of the ammonia oxidation catalyst:**

Azomures uses various types of oxidation catalysts. Composition of oxidation catalysts depends on latest technical knowledge of oxidation catalyst manufacturers as well as actual price of precious metals. Composition of all 11 oxidation catalysts installed during the baseline measurements were in line with compositions used in 5 previous campaigns. Same shall apply also to composition of oxidation catalysts to be used in subsequent project campaigns.

Parameters monitored for composition of the catalyst are as follows:

| | |
|-------------------|---|
| $G_{S_{normal}}$ | Gauze supplier for the operation condition campaigns |
| $G_{S_{BL}}$ | Gauze supplier for baseline campaign |
| $G_{S_{project}}$ | Gauze supplier for the project campaign |
| G_{normal} | Gauze composition for the operation condition campaigns |
| $G_{C_{BL}}$ | Gauze composition for baseline campaign |
| $G_{C_{project}}$ | Gauze composition for the project campaign |

Campaign Length

In order to take into account the variations in campaign length and its influence on N_2O emission levels, the historic campaign lengths and the baseline campaign length have been determined and compared to the project campaign length. Campaign length is defined as the total number of metric tonnes of nitric acid at 100% concentration produced with one set of gauzes.

Historic Campaign Length

The average historic campaign length (CL_{normal}) defined as the average campaign length for the historic campaigns used to define operating condition (the previous four campaigns), has been used as a cap on the length of the baseline campaign.

Baseline Campaign Length (CL_{BL})

If $CL_{BL} \leq CL_{normal}$

all N_2O values measured during the baseline campaign can be used for the calculation of EF_{BL} (subject to the elimination of data that was monitored during times where the plant was operating outside of the “permitted range”).

If $CL_{BL} > CL_{normal}$

N_2O values that were measured beyond the length of CL_{normal} during the production of the quantity of nitric acid (i.e. the final tonnes produced) are to be eliminated from the calculation of EF_{BL} .

**D. 1.2. Option 2 – Direct monitoring of emission reductions from the project (values should be consistent with those in section E.):**

This option was not used

D.1.2.1. Data to be collected in order to monitor emission reductions from the project, and how these data will be archived:

| ID number (Please use numbers to ease cross-referencing to D.2.) | Data variable | Source of data | Data unit | Measured (m), calculated (c), estimated (e) | Recording frequency | Proportion of data to be monitored | How will the data be archived? (electronic/ paper) | Comment |
|---|---------------|----------------|-----------|---|------------------------|--|--|---------|
| | | | | | | | | |
| | | | | | | | | |

D.1.2.2. Description of formulae used to calculate emission reductions from the project (for each gas, source etc.; emissions/emission reductions in units of CO₂ equivalent):

Not applicable

D.1.3. Treatment of leakage in the monitoring plan:

Due to nature of the project there is no leakage calculation required by the AM0034.

D.1.3.1. If applicable, please describe the data and information that will be collected in order to monitor leakage effects of the project:

| ID number (Please use numbers to ease cross-referencing to D.2.) | Data variable | Source of data | Data unit | Measured (m), calculated (c), estimated (e) | Recording frequency | Proportion of data to be monitored | How will the data be archived? (electronic/ paper) | Comment |
|---|---------------|----------------|-----------|---|------------------------|--|--|---------|
| | | | | | | | | |
| | | | | | | | | |

**D.1.3.2. Description of formulae used to estimate leakage (for each gas, source etc.; emissions in units of CO₂ equivalent):**

Not applicable

D.1.4. Description of formulae used to estimate emission reductions for the project (for each gas, source etc.; emissions/emission reductions in units of CO₂ equivalent):

The emission reductions for the project activity over a specific campaign are determined by deducting the campaign-specific emission factor from the baseline emission factor and multiplying the result by the production output of 100% concentrated nitric acid over the campaign period and the GWP of N₂O:

$$ER = (EF_{BL} - EF_P) * NAP * GWP_{N_2O} \text{ (tCO}_2\text{e)}$$

Where:

Variable DefinitionER Emission reductions of the project for the specific campaign (tCO₂e)NAP Nitric acid production for the project campaign (tHNO₃). The maximum value of NAP shall not exceed the design capacity.EF_{BL} Baseline emissions factor (tN₂O/tHNO₃)EF_P Emissions factor used to calculate the emissions from this particular campaign (i.e. the higher of EF_{ma,n} and EF_n)

By nameplate (design) implies the total yearly capacity (considering 365 days of operation per year) as per the documentation of the plant technology provider (such as the Operation Manual). If the plant has been modified to increase production, and such de-bottleneck or expansion projects were completed before December 2005, then the new capacity is considered nameplate, provided proper documentation of the projects is available (such as, but not limited to: properly dated engineering plans or blueprints, engineering, materials and/or equipment expenses, or third party construction services, etc.).

D.1.5. Where applicable, in accordance with procedures as required by the host Party, information on the collection and archiving of information on the environmental impacts of the project:

Since N₂O is not a pollutant regulated by national legislation, it does not have any negative impact on an environment in vicinity of its point of emitting and it does not have any significant and attributable impact on population living in the plant's vicinity, it is not required to carry out the environmental impact study.

D.2. Quality control (QC) and quality assurance (QA) procedures undertaken for data monitored:

| Data (Indicate table and ID number) | Uncertainty level of data (high/medium/low) | Explain QA/QC procedures planned for these data, or why such procedures are not necessary. |
|--|--|--|
| | | |



| | | |
|---|-----|--|
| P.1, B.1 NCSG _{BC, 2,3,4} N ₂ O concentration in the stack gas for particular plant | Low | N ₂ O analyser MIR9000 QAL1 suitability calculations carried, QAL2 test carried, QAL3 procedures carried out at the plant |
| P.2, B.2 VSG _{BC, 2,3,4} Volume flow rate of the stack gas for particular plant | Low | Gas volume flow meter ABB QAL1 certified, QAL2 test carried |
| P.6, B.6 TSG _{2,3,4} Temperature of stack gas for particular plant | Low | Regular calibration and control according to existing measurement requirements |
| P.7, B.7 PSG _{2,3,4} Pressure of stack gas for particular plant | Low | Regular calibration and control according to existing measurement requirements |
| B.9 UNC _{2,3,4} Overall measurement uncertainty of the monitoring system | Low | Regular calibration and control according to existing measurement requirements |
| B.10 AIFR _{2,3,4} Ammonia gas flow rate to the AOR for particular plant | Low | Regular calibration and control according to existing measurement requirements |



| | | |
|--|-----|--|
| B.16 $OT_{h,2,3,4}$ Oxidation temperature for each hour for particular plant | Low | Regular calibration and control according to existing measurement requirements |
| B.18 $OP_{h,2,3,4}$ Oxidation pressure for each hour for particular plant | Low | Regular calibration and control according to existing measurement requirements |

D.3. Please describe the operational and management structure that the project operator will apply in implementing the monitoring plan:

Monitoring plan shall be implemented in accordance with plant operation manual, national requirements for emission measurements, specific requirements of the EN14181 norm and requirements of this JI project using methodology AM0034.

D.4. Name of person(s)/entity(ies) establishing the monitoring plan:

Mr. Laszlo Pasztor

**SECTION E. Estimation of greenhouse gas emission reductions****E.1. Estimated project emissions:**281,699 tCO₂e/year**E.2. Estimated leakage:**

No leakage

E.3. The sum of E.1. and E.2.:281,699 tCO₂e/year**E.4. Estimated baseline emissions:**1,482,627 tCO₂e/year**E.5. Difference between E.4. and E.3. representing the emission reductions of the project:**1,200,928 tCO₂e/year**E.6. Table providing values obtained when applying formulae above:**

| Year | Estimated project emissions in tCO ₂ e/year | Estimated leakage in tCO ₂ e/year | Estimated baseline emissions in tCO ₂ e/year | Estimated emission reductions in tCO ₂ e/year |
|----------------------------------|--|--|---|--|
| 2008 | 126,571 | 0 | 666,161 | 539,590 |
| 2009 | 314,576 | 0 | 1,655,662 | 1,341,086 |
| 2010 | 322,450 | 0 | 1,697,105 | 1,374,655 |
| 2011 | 322,450 | 0 | 1,697,105 | 1,374,655 |
| 2012 | 322,450 | 0 | 1,697,105 | 1,374,655 |
| Total in tCO₂e | 1,408,496 | 0 | 7,413,137 | 6,004,641 |

SECTION F. Environmental impacts**F.1. Documentation on the analysis of the environmental impacts of the project, including transboundary impacts, in accordance with procedures as determined by the host Party:**

Since N₂O is not a pollutant regulated by national legislation, it does not have any negative impact on an environment in vicinity of its point of emitting and it does not have any significant and attributable impact on population living in the plant's vicinity, it is not required to carry out the environmental impact study.

F.2. If environmental impacts are considered significant by the project participants or the host Party, please provide conclusions and all references to supporting documentation of an



environmental impact assessment undertaken in accordance with the procedures as required by the host Party:

This type of project does not require to carry the EIA study.

SECTION G. Stakeholders' comments

G.1. Information on stakeholders' comments on the project, as appropriate:

This type of project does not require to carry the EIA study, neither requires public stakeholders involvement.

Annex 1**CONTACT INFORMATION ON PROJECT PARTICIPANTS***Project owner*

| | |
|------------------|--|
| Organisation: | AZOMURES SA |
| Street/P.O.Box: | Gh. Doja street |
| Building: | 300 |
| City: | Tirgu Mures |
| State/Region: | Mures county |
| Postal code: | 540 237 |
| Country: | Romania |
| Phone: | +40 265 25 37 00 |
| Fax: | +40 265 25 26 27 |
| E-mail: | office@azomures.com |
| URL: | http://www.azomures.com |
| Represented by: | Ioan Soleriu |
| Title: | Technical Executive Manager |
| Salutation: | Mr |
| Last name: | Soleriu |
| Middle name: | - |
| First name: | Ioan |
| Department: | Fertilizer Complex |
| Phone (direct): | +40 265 25 27 14 |
| Fax (direct): | +40 265 25 26 27 |
| Mobile: | +40 744 645 739 |
| Personal e-mail: | dir_teh@azomures.com |

*JI project advisor*

| | |
|------------------|--|
| Organisation: | Vertis Environmental Finance Zrt |
| Street/P.O.Box: | Alkotás utca |
| Building: | 39c |
| City: | Budapest |
| State/Region: | Pest megye |
| Postal code: | 1123 |
| Country: | Hungary |
| Phone: | +36 1 488 8410 |
| Fax: | +36 1 488 8411 |
| E-mail: | info@vertisfinance.com |
| URL: | www.vertisfinance.com |
| Represented by: | Laszlo Pasztor |
| Title: | Director |
| Salutation: | Mr |
| Last name: | Pasztor |
| Middle name: | - |
| First name: | Laszlo |
| Department: | - |
| Phone (direct): | +36 1 488 8423 |
| Fax (direct): | +36 1 488 8411 |
| Mobile: | +36 20 973 5439 |
| Personal e-mail: | laszlo.pasztor@vertisfinance.com |

Annex 2**BASELINE INFORMATION**

Baseline information will be inserted after completion of baseline measurements in May 2008 (NA3) and in August 2008(NA2 and NA4). Emission estimates contained in the PDD document have been based on following assumptions:

| Main assumptions | Acid 2 | Acid 3 | Acid 4 | TOTAL |
|---------------------------|---------------|---------------|---------------|----------------------|
| Plate Capacity | 725 | 725 | 750 | 2,200 t/Day |
| Average Production | 7,680 | 7,680 | 7,680 | 23,040 t/Day |
| Annual Production | 232,000 | 232,000 | 240,000 | 704,000 t/year |
| N2O Concentration | 1,013 | 1,500 | 1,091 | 1,200 ppmv |
| N2O Emission | 6.56 | 9.72 | 7.07 | 7.78 kg/t |
| Annual N2O Emission | 1,522,557 | 2,254,719 | 1,697,256 | 5,474,532 kg/year |
| Annual N2O Emission | 471,993 | 698,963 | 526,149 | 1,697,105 tCO2e/year |
| Emission Reduction Factor | 81% | 81% | 81% | |



Annex 3

MONITORING PLAN

In order to establish a definitive baseline, N₂O measuring instruments were installed in the lines in the plants NA2, NA3 and NA4. Continuous measurements were made throughout the duration of one production campaign in all 3 plants. To ensure the integrity of the data from these measurements and the suitability of the data for inclusion in the Baseline Study within the Project Design Documentation, the measurements will be validated by an Accredited Independent Entity - respected and experienced validator in the field of Joint Implementation.

N₂O emissions monitoring system consists of the measurement devices part and data processing and storage part.

MONITORING SYSTEM DESCRIPTION NITRIC ACID 2 PLANT

K. Main air flow

- the measuring point is located on the compressor air discharge pipe
- diaphragm type sensor with ring-like chambers
- operating conditions: p = 2.5 – 3 bars, t = 150°C
- pneumatic signal transmission between the sensor and the transducer through 2 impulse pipes, approx. 10 m long
- measuring device: Fischer Roesmount differential electronic transducer, having a measuring range between 0 – 45.24 mbar; output signal: analogue 4 – 20 mA
- signal transmission: electric wires, approx. 30 m long, analogue signal 4 – 20 mA
- signal conversion device: ISU 24M digital indicator; placed inside the control panel; converts the analogue signal into digital signal; recording period: 2 seconds.
- data recorded into the “data logger” are transmitted through an optic fiber network to a computer designated particularly for this type of monitoring. This computer is located in the Instrumentation Plant. Data are stored in a database on the computer’s hard disk. From this database data are afterwards processed in order to obtain all data necessary for the project. The entire database is periodically saved on graphic and magnetic support as an Excel file.

L. Secondary air flow

- the measuring point is located on the air compressor discharge pipe
- diaphragm type sensor with ring-like chambers
- operating conditions: p = 2.5 – 3 bars, t = 150°C
- pneumatic signal transmission between the sensor and the transducer through 2 impulse pipes, approx. 15 m long
- measuring device: Fischer Roesmount differential electronic transducer, having a measuring range between 0 – 500 mm H₂O; output signal: analogue 4 – 20 mA
- signal transmission: electric wires, approx. 50 m long, analogue signal 4 – 20 mA
- signal conversion device: ISU 24M digital indicator; placed inside the control panel; converts the analogue signal into digital signal; recording period: 2 seconds.
- data recorded into the “data logger” are transmitted through an optic fiber network to a computer designated particularly for this type of monitoring. This computer is located in



the Instrumentation Plant. Data are stored in a database on the computer's hard disk. From this database data are afterwards processed in order to obtain all data necessary for the project. The entire database is periodically saved on graphic and magnetic support as an Excel file.

M. Reactor sieves temperature

- the measuring point is located on the oxidation reactor; sensor; PtRh-Pt thermocouple, operating conditions: $t = 800 - 1000^{\circ}\text{C}$
- electric signal transmission between the sensor and the transducer: PtRh-Pt correction cable, approx. 50 m long
- digital indicator measuring device; measuring range between $0 - 1000^{\circ}\text{C}$; analogue output signal $4 - 20 \text{ mA}$
- signal transmission: electric wires, approx. 6 m long, analogue signal $4 - 20 \text{ mA}$
- signal conversion device: ISU 24M digital indicator; placed inside the control panel; converts the analogue signal into digital signal; recording period: 2 seconds.
- data recorded into the "data logger" are transmitted through an optic fiber network to a computer designated particularly for this type of monitoring. This computer is located in the Instrumentation Plant. Data are stored in a database on the computer's hard disk. From this database data are afterwards processed in order to obtain all data necessary for the project. The entire database is periodically saved on graphic and magnetic support as an Excel file.

N. Consumed liquid ammonia flow

- the measuring point is located on the ammonia evaporator inlet pipe; Coriolis type sensor; operating conditions: $p = 12 \text{ bar}$, $t = 8 - 10^{\circ}\text{C}$
- electric signal transmission between the sensor and the transducer: 2-wire cable, approx. 90 m long
- measuring device: DZL363 flowmeter adapter produced by Endress&Hauser; measuring range between $0 - 20 \text{ t/h}$; analogue output signal $4 - 20 \text{ mA}$
- signal transmission: electric wires, approx. 10 m long, analogue signal $4 - 20 \text{ mA}$
- signal conversion device: ISU 24M digital indicator; placed inside the control panel; converts the analogue signal into digital signal; recording period: 2 seconds.
- data recorded into the "data logger" are transmitted through an optic fiber network to a computer designated particularly for this type of monitoring. This computer is located in the Instrumentation Plant. Data are stored in a database on the computer's hard disk. From this database data are afterwards processed in order to obtain all data necessary for the project. The entire database is periodically saved on graphic and magnetic support as an Excel file.

O. Flow of produced nitric acid

- the measuring point is located on the column 4 outlet pipe towards the nitric acid storehouse; electromagnetic sensor; operating conditions: $p = 2.5 \text{ bar}$, $t = 40^{\circ}\text{C}$
- electric signal transmission between the sensor and the transducer: 2-wire cable, approx. 100 m long
- measuring device: DZL363 flowmeter adapter produced by Endress&Hauser; measuring range between $0 - 100 \text{ t/h}$; analogue output signal $4 - 20 \text{ mA}$
- signal transmission: electric wires, approx. 5 m long, analogue signal $4 - 20 \text{ mA}$



- signal conversion device: ISU 24M digital indicator; placed inside the control panel; converts the analogue signal into digital signal; recording period: 2 seconds.
- data recorded into the “data logger” are transmitted through an optic fiber network to a computer designated particularly for this type of monitoring. This computer is located in the Instrumentation Plant. Data are stored in a database on the computer’s hard disk. From this database data are afterwards processed in order to obtain all data necessary for the project. The entire database is periodically saved on graphic and magnetic support as an Excel file.

P. Temperature of produced nitric acid

- the measuring point is located on the column 4 outlet pipe towards the nitric acid storehouse; Coriolis type sensor; operating conditions: $p = 2.5$ bar, $t = 40^{\circ}\text{C}$
- electric signal transmission between the sensor and the transducer: 2-wire cable, approx. 100 m long
- measuring device: DZL363 flowmeter adapter produced by Endress&Hauser; measuring range between $-50 - 200^{\circ}\text{C}$; analogue output signal 4 – 20 mA
- signal transmission: electric wires, approx. 5 m long, analogue signal 4 – 20 mA
- signal conversion device: ISU 24M digital indicator; placed inside the control panel; converts the analogue signal into digital signal; recording period: 2 seconds.
- data recorded into the “data logger” are transmitted through an optic fiber network to a computer designated particularly for this type of monitoring. This computer is located in the Instrumentation Plant. Data are stored in a database on the computer’s hard disk. From this database data are afterwards processed in order to obtain all data necessary for the project. The entire database is periodically saved on graphic and magnetic support as an Excel file.

Q. Density of produced nitric acid

- the measuring point is located on the column 4 outlet pipe towards the nitric acid storehouse; Coriolis type sensor; operating conditions: $p = 2.5$ bar, $t = 40^{\circ}\text{C}$
- electric signal transmission between the sensor and the transducer: 2-wire cable, approx. 100 m long
- measuring device: DZL363 flowmeter adapter produced by Endress&Hauser; measuring range between 1.2 – 1.4 kg/l; analogue output signal 4 – 20 mA
- signal transmission: electric wires, approx. 5 m long, analogue signal 4 – 20 mA
- signal conversion device: ISU 24M digital indicator; placed inside the control panel; converts the analogue signal into digital signal; recording period: 2 seconds.
- data recorded into the “data logger” are transmitted through an optic fiber network to a computer designated particularly for this type of monitoring. This computer is located in the Instrumentation Plant. Data are stored in a database on the computer’s hard disk. From this database data are afterwards processed in order to obtain all data necessary for the project. The entire database is periodically saved on graphic and magnetic support as an Excel file.

R. Tail gases flow, tail gases pressure, tail gases temperature

- the measuring point is located on the expansion turbine outlet pipe towards the discharge nozzle; Pytot type sensor with multiple holes; operating conditions: absolute $p = 2.5$ bar, $t = 80^{\circ}\text{C}$



- pneumatic connection line (12 mm diameter and approx. 1 m long hoses) between the sensor and the electric switch box where the Dp cell is located; pneumatic connection line (6 mm diameter and approx. 2 m long hose) between the sensor and the electric switch box where the absolute pressure measuring cell is located
- measuring device: Dp differential transducer, produced by ABB, measuring range between 0 – 30 mbar; absolute pressure transducer produced by Endress&Hauser, measuring range between 0 – 0.3 bar; Pt100 thermal resistance with built-in adapter, measuring range between 0 - 200°C; analogue output signal 4 – 20 mA
- signal transmission: electric wires, approx. 5 m long, analogue signal 4 – 20 mA
- signal conversion device: ISU 24M digital indicator; placed inside the control panel; converts the analogue signal into digital signal; recording period: 2 seconds.
- data recorded into the “data logger” are transmitted through an optic fiber network to a computer designated particularly for this type of monitoring. This computer is located in the Instrumentation Plant. Data are stored in a database on the computer’s hard disk. From this database data are afterwards processed in order to obtain all data necessary for the project. The entire database is periodically saved on graphic and magnetic support as an Excel file.

S. Oxidation reactor pressure

- the measuring point is located on the air compressor discharge pipe; sensor type: capsule for electronic transducer; operating conditions: absolute $p = 3.5$ bar, $t = 200^{\circ}\text{C}$
- pneumatic connection line between the sensor and the transducer; pneumatic connection line of 8 mm diameter and approx. 10 m long
- measuring device: Foxboro transducer, measuring range between 0 – 5 bar; absolute pressure transducer produced by Endress&Hauser, measuring range between 0 – 0.3 bar; Pt100 thermal resistance with built-in adapter, measuring range between 0 - 200°C; analogue output signal 4 – 20 mA
- signal transmission: electric wires, approx. 50 m long, analogue signal 4 – 20 mA
- signal conversion device: ISU 24M digital indicator; placed inside the control panel; converts the analogue signal into digital signal; recording period: 2 seconds.
- data recorded into the “data logger” are transmitted through an optic fiber network to a computer designated particularly for this type of monitoring. This computer is located in the Instrumentation Plant. Data are stored in a database on the computer’s hard disk. From this database data are afterwards processed in order to obtain all data necessary for the project. The entire database is periodically saved on graphic and magnetic support as an Excel file.

T. N₂O concentration

- the impulse line is the same as the NO_x outlet line
- the circuit is the same as for measuring NO_x outlet concentration, including up to the pressure reducing valve outlet.
- the gas for the N₂O analyzer is taken from here through a water discharge cooler. The analyzer is produced by Environement S.A., France and is based on non-dispersive infrared absorption principle; it is placed in the same cabinet as the NO_x analyzer. The N₂O concentration measurement range is between 0 – 2000 ppm.
- the outlet analyzer signal is of 4 – 20 mA, proportional to the value of the concentration. This signal is transmitted through an electric cable at the plant’s central control panel. The electric cable is approx. 100 m long.



- the device that converts the 4 – 20 mA signal in nitrogen oxides concentration is a ISU – MMC- 24C digital indicator produced by Infostar Pascani. The device has 16 inlet circuits of 4 – 20 mA. The readings are digitally displayed and are recorded every 2 seconds. Data recorded into the “data logger” are transmitted through an optic fiber network to a computer designated particularly for this type of monitoring. This computer is located in the Instrumentation Plant. Data are stored in a database on the computer’s hard disk. From this database data are afterwards processed in order to obtain all data necessary for the project. The entire database is periodically saved on graphic and magnetic support as an Excel file.

MONITORING SYSTEM DESCRIPTION NITRIC ACID 3 PLANT

L. Main air flow

- the measuring point is located on the compressor air discharge pipe
- diaphragm type sensor with ring-like chambers
- operating conditions: $p = 2.5 - 3$ bars, $t = 150^{\circ}\text{C}$
- pneumatic signal transmission between the sensor and the transducer through 2 impulse pipes, approx. 10 m long
- measuring device: Fischer Roesmount differential electronic transducer, having a measuring range between 0 – 45.24 mbar; output signal: analogue 4 – 20 mA
- signal transmission: electric wires, approx. 30 m long, analogue signal 4 – 20 mA
- signal conversion device: ISU 24M digital indicator; placed inside the control panel; converts the analogue signal into digital signal; recording period: 2 seconds.
- data recorded into the “data logger” are transmitted through an optic fiber network to a computer designated particularly for this type of monitoring. This computer is located in the Instrumentation Plant. Data are stored in a database on the computer’s hard disk. From this database data are afterwards processed in order to obtain all data necessary for the project. The entire database is periodically saved on graphic and magnetic support as an Excel file.

M. Secondary air flow

- the measuring point is located on the air compressor discharge pipe
- diaphragm type sensor with ring-like chambers
- operating conditions: $p = 2.5 - 3$ bars, $t = 150^{\circ}\text{C}$
- pneumatic signal transmission between the sensor and the transducer through 2 impulse pipes, approx. 15 m long
- measuring device: Fischer Roesmount differential electronic transducer, having a measuring range between 0 – 500 mm H₂O; output signal: analogue 4 – 20 mA
- signal transmission: electric wires, approx. 50 m long, analogue signal 4 – 20 mA
- signal conversion device: ISU 24M digital indicator; placed inside the control panel; converts the analogue signal into digital signal; recording period: 2 seconds.
- data recorded into the “data logger” are transmitted through an optic fiber network to a computer designated particularly for this type of monitoring. This computer is located in the Instrumentation Plant. Data are stored in a database on the computer’s hard disk. From this database data are afterwards processed in order to obtain all data necessary for the project. The entire database is periodically saved on graphic and magnetic support as an Excel file.

**N. Casing protection air flow**

- the measuring point is located on the air duct to the reactors casing, ramifications from the compressor discharge pipe
- diaphragm type sensor with ring-like chambers
- operating conditions: $p = 2.5 - 3$ bars, $t = 150^{\circ}\text{C}$
- pneumatic signal transmission between the sensor and the transducer through 2 impulse pipes, approx. 10 m long
- measuring device: FEPA Birlad differential electronic transducer, having a measuring range between 0 – 1500 mm H₂O; output signal: analogue 4 – 20 mA
- signal transmission: electric wires, approx. 60 m long, analogue signal 4 – 20 mA
- signal conversion device: ISU 24M digital indicator; placed inside the control panel; converts the analogue signal into digital signal; recording period: 2 seconds.
- data recorded into the “data logger” are transmitted through an optic fiber network to a computer designated particularly for this type of monitoring. This computer is located in the Instrumentation Plant. Data are stored in a database on the computer’s hard disk. From this database data are afterwards processed in order to obtain all data necessary for the project. The entire database is periodically saved on graphic and magnetic support as an Excel file.

O. Reactor sieves temperature

- the measuring point is located on the oxidation reactor; sensor; PtRh-Pt thermocouple, operating conditions: $t = 800 - 1000^{\circ}\text{C}$
- electric signal transmission between the sensor and the transducer: PtRh-Pt correction cable, approx. 50 m long
- digital indicator measuring device; measuring range between 0 – 1000 $^{\circ}\text{C}$; analogue output signal 4 – 20 mA
- signal transmission: electric wires, approx. 6 m long, analogue signal 4 – 20 mA
- signal conversion device: ISU 24M digital indicator; placed inside the control panel; converts the analogue signal into digital signal; recording period: 2 seconds.
- data recorded into the “data logger” are transmitted through an optic fiber network to a computer designated particularly for this type of monitoring. This computer is located in the Instrumentation Plant. Data are stored in a database on the computer’s hard disk. From this database data are afterwards processed in order to obtain all data necessary for the project. The entire database is periodically saved on graphic and magnetic support as an Excel file.

P. Consumed liquid ammonia flow

- the measuring point is located on the ammonia evaporator inlet pipe; Coriolis type sensor; operating conditions: $p = 12$ bar, $t = 8 - 10^{\circ}\text{C}$
- electric signal transmission between the sensor and the transducer: 2-wire cable, approx. 90 m long
- measuring device: DZL363 flowmeter adapter produced by Endress&Hauser; measuring range between 0 – 20 t/h; analogue output signal 4 – 20 mA
- signal transmission: electric wires, approx. 10 m long, analogue signal 4 – 20 mA
- signal conversion device: ISU 24M digital indicator; placed inside the control panel; converts the analogue signal into digital signal; recording period: 2 seconds.



- data recorded into the “data logger” are transmitted through an optic fiber network to a computer designated particularly for this type of monitoring. This computer is located in the Instrumentation Plant. Data are stored in a database on the computer’s hard disk. From this database data are afterwards processed in order to obtain all data necessary for the project. The entire database is periodically saved on graphic and magnetic support as an Excel file.

Q. Flow of produced nitric acid

- the measuring point is located on the column 4 outlet pipe towards the nitric acid storehouse; electromagnetic sensor; operating conditions: $p = 2.5 \text{ bar}$, $t = 40^\circ\text{C}$
- electric signal transmission between the sensor and the transducer: 2-wire cable, approx. 100 m long
- measuring device: DZL363 flowmeter adapter produced by Endress&Hauser; measuring range between 0 – 100 t/h; analogue output signal 4 – 20 mA
- signal transmission: electric wires, approx. 5 m long, analogue signal 4 – 20 mA
- signal conversion device: ISU 24M digital indicator; placed inside the control panel; converts the analogue signal into digital signal; recording period: 2 seconds.
- data recorded into the “data logger” are transmitted through an optic fiber network to a computer designated particularly for this type of monitoring. This computer is located in the Instrumentation Plant. Data are stored in a database on the computer’s hard disk. From this database data are afterwards processed in order to obtain all data necessary for the project. The entire database is periodically saved on graphic and magnetic support as an Excel file.

R. Temperature of produced nitric acid

- the measuring point is located on the column 4 outlet pipe towards the nitric acid storehouse; Coriolis type sensor; operating conditions: $p = 2.5 \text{ bar}$, $t = 40^\circ\text{C}$
- electric signal transmission between the sensor and the transducer: 2-wire cable, approx. 100 m long
- measuring device: DZL363 flowmeter adapter produced by Endress&Hauser; measuring range between $-50 - 200^\circ\text{C}$; analogue output signal 4 – 20 mA
- signal transmission: electric wires, approx. 5 m long, analogue signal 4 – 20 mA
- signal conversion device: ISU 24M digital indicator; placed inside the control panel; converts the analogue signal into digital signal; recording period: 2 seconds.
- data recorded into the “data logger” are transmitted through an optic fiber network to a computer designated particularly for this type of monitoring. This computer is located in the Instrumentation Plant. Data are stored in a database on the computer’s hard disk. From this database data are afterwards processed in order to obtain all data necessary for the project. The entire database is periodically saved on graphic and magnetic support as an Excel file.

S. Density of produced nitric acid

- the measuring point is located on the column 4 outlet pipe towards the nitric acid storehouse; Coriolis type sensor; operating conditions: $p = 2.5 \text{ bar}$, $t = 40^\circ\text{C}$
- electric signal transmission between the sensor and the transducer: 2-wire cable, approx. 100 m long



- measuring device: DZL363 flowmeter adapter produced by Endress&Hauser; measuring range between 1.2 – 1.4 kg/l; analogue output signal 4 – 20 mA
- signal transmission: electric wires, approx. 5 m long, analogue signal 4 – 20 mA
- signal conversion device: ISU 24M digital indicator; placed inside the control panel; converts the analogue signal into digital signal; recording period: 2 seconds.
- data recorded into the “data logger” are transmitted through an optic fiber network to a computer designated particularly for this type of monitoring. This computer is located in the Instrumentation Plant. Data are stored in a database on the computer’s hard disk. From this database data are afterwards processed in order to obtain all data necessary for the project. The entire database is periodically saved on graphic and magnetic support as an Excel file.

T. Tail gases flow, tail gases pressure, tail gases temperature

- the measuring point is located on the expansion turbine outlet pipe towards the discharge nozzle; Pytot type sensor with multiple holes; operating conditions: absolute $p = 2.5$ bar, $t = 80^{\circ}\text{C}$
- pneumatic connection line (12 mm diameter and approx. 1 m long hoses) between the sensor and the electric switch box where the Dp cell is located; pneumatic connection line (6 mm diameter and approx. 2 m long hose) between the sensor and the electric switch box where the absolute pressure measuring cell is located
- measuring device: Dp differential transducer, produced by ABB, measuring range between 0 – 30 mbar; absolute pressure transducer produced by Endress&Hauser, measuring range between 0 – 0.3 bar; Pt100 thermal resistance with built-in adapter, measuring range between 0 - 200°C ; analogue output signal 4 – 20 mA
- signal transmission: electric wires, approx. 5 m long, analogue signal 4 – 20 mA
- signal conversion device: ISU 24M digital indicator; placed inside the control panel; converts the analogue signal into digital signal; recording period: 2 seconds.
- data recorded into the “data logger” are transmitted through an optic fiber network to a computer designated particularly for this type of monitoring. This computer is located in the Instrumentation Plant. Data are stored in a database on the computer’s hard disk. From this database data are afterwards processed in order to obtain all data necessary for the project. The entire database is periodically saved on graphic and magnetic support as an Excel file.

U. Oxidation reactor pressure

- the measuring point is located on the air compressor discharge pipe; sensor type: capsule for electronic transducer; operating conditions: absolute $p = 3.5$ bar, $t = 200^{\circ}\text{C}$
- pneumatic connection line between the sensor and the transducer; pneumatic connection line of 8 mm diameter and approx. 10 m long
- measuring device: Foxboro transducer, measuring range between 0 – 5 bar; absolute pressure transducer produced by Endress&Hauser, measuring range between 0 – 0.3 bar; Pt100 thermal resistance with built-in adapter, measuring range between 0 - 200°C ; analogue output signal 4 – 20 mA
- signal transmission: electric wires, approx. 50 m long, analogue signal 4 – 20 mA
- signal conversion device: ISU 24M digital indicator; placed inside the control panel; converts the analogue signal into digital signal; recording period: 2 seconds.



- data recorded into the “data logger” are transmitted through an optic fiber network to a computer designated particularly for this type of monitoring. This computer is located in the Instrumentation Plant. Data are stored in a database on the computer’s hard disk. From this database data are afterwards processed in order to obtain all data necessary for the project. The entire database is periodically saved on graphic and magnetic support as an Excel file.

V. N₂O concentration

- the impulse line is the same as the NO_x outlet line
- the circuit is the same as for measuring NO_x outlet concentration, including up to the pressure reducing valve outlet.
- the gas for the N₂O analyzer is taken from here through a water discharge cooler. The analyzer is produced by Environement S.A., France and is based on non-dispersive infrared absorption principle; it is placed in the same cabinet as the NO_x analyzer. The N₂O concentration measurement range is between 0 – 2000 ppm.
- the outlet analyzer signal is of 4 – 20 mA, proportional to the value of the concentration. This signal is transmitted through an electric cable at the plant’s central control panel. The electric cable is approx. 100 m long.
- the device that converts the 4 – 20 mA signal in nitrogen oxides concentration is a ISU – MMC- 24C digital indicator produced by Infostar Pascani. The device has 16 inlet circuits of 4 – 20 mA. The readings are digitally displayed and are recorded every 2 seconds. Data recorded into the “data logger” are transmitted through an optic fiber network to a computer designated particularly for this type of monitoring. This computer is located in the Instrumentation Plant. Data are stored in a database on the computer’s hard disk. From this database data are afterwards processed in order to obtain all data necessary for the project. The entire database is periodically saved on graphic and magnetic support as an Excel file.

MONITORING SYSTEM DESCRIPTION NITRIC ACID 4 PLANT

K. Main air flow

- the measuring point is located on the compressor air discharge pipe
- diaphragm type sensor with ring-like chambers
- operating conditions: p = 2.5 – 3 bars, t = 150°C
- pneumatic signal transmission between the sensor and the transducer through 2 impulse pipes, approx. 10 m long
- measuring device: Fischer Roesmount differential electronic transducer, having a measuring range between 0 – 45.24 mbar; output signal: analogue 4 – 20 mA
- signal transmission: electric wires, approx. 30 m long, analogue signal 4 – 20 mA
- signal conversion device: ISU 24M digital indicator; placed inside the control panel; converts the analogue signal into digital signal; recording period: 2 seconds.
- data recorded into the “data logger” are transmitted through an optic fiber network to a computer designated particularly for this type of monitoring. This computer is located in the Instrumentation Plant. Data are stored in a database on the computer’s hard disk. From this database data are afterwards processed in order to obtain all data necessary for

the project. The entire database is periodically saved on graphic and magnetic support as an Excel file.

L. Secondary air flow

- the measuring point is located on the air compressor discharge pipe
- diaphragm type sensor with ring-like chambers
- operating conditions: $p = 2.5 - 3$ bars, $t = 150^{\circ}\text{C}$
- pneumatic signal transmission between the sensor and the transducer through 2 impulse pipes, approx. 15 m long
- measuring device: Fischer Roesmount differential electronic transducer, having a measuring range between 0 – 500 mm H₂O; output signal: analogue 4 – 20 mA
- signal transmission: electric wires, approx. 50 m long, analogue signal 4 – 20 mA
- signal conversion device: ISU 24M digital indicator; placed inside the control panel; converts the analogue signal into digital signal; recording period: 2 seconds.
- data recorded into the “data logger” are transmitted through an optic fiber network to a computer designated particularly for this type of monitoring. This computer is located in the Instrumentation Plant. Data are stored in a database on the computer’s hard disk. From this database data are afterwards processed in order to obtain all data necessary for the project. The entire database is periodically saved on graphic and magnetic support as an Excel file.

M. Reactor sieves temperature

- the measuring point is located on the oxidation reactor; sensor; PtRh-Pt thermocouple, operating conditions: $t = 800 - 1000^{\circ}\text{C}$
- electric signal transmission between the sensor and the transducer: PtRh-Pt correction cable, approx. 50 m long
- digital indicator measuring device; measuring range between 0 – 1000°C; analogue output signal 4 – 20 mA
- signal transmission: electric wires, approx. 6 m long, analogue signal 4 – 20 mA
- signal conversion device: ISU 24M digital indicator; placed inside the control panel; converts the analogue signal into digital signal; recording period: 2 seconds.
- data recorded into the “data logger” are transmitted through an optic fiber network to a computer designated particularly for this type of monitoring. This computer is located in the Instrumentation Plant. Data are stored in a database on the computer’s hard disk. From this database data are afterwards processed in order to obtain all data necessary for the project. The entire database is periodically saved on graphic and magnetic support as an Excel file.

N. Consumed liquid ammonia flow

- the measuring point is located on the ammonia evaporator inlet pipe; Coriolis type sensor; operating conditions: $p = 12$ bar, $t = 8 - 10^{\circ}\text{C}$
- electric signal transmission between the sensor and the transducer: 2-wire cable, approx. 90 m long
- measuring device: DZL363 flowmeter adapter produced by Endress&Hauser; measuring range between 0 – 20 t/h; analogue output signal 4 – 20 mA
- signal transmission: electric wires, approx. 10 m long, analogue signal 4 – 20 mA



- signal conversion device: ISU 24M digital indicator; placed inside the control panel; converts the analogue signal into digital signal; recording period: 2 seconds.
- data recorded into the “data logger” are transmitted through an optic fiber network to a computer designated particularly for this type of monitoring. This computer is located in the Instrumentation Plant. Data are stored in a database on the computer’s hard disk. From this database data are afterwards processed in order to obtain all data necessary for the project. The entire database is periodically saved on graphic and magnetic support as an Excel file.

O. Flow of produced nitric acid

- the measuring point is located on the column 4 outlet pipe towards the nitric acid storehouse; electromagnetic sensor; operating conditions: $p = 2.5 \text{ bar}$, $t = 40^\circ\text{C}$
- electric signal transmission between the sensor and the transducer: 2-wire cable, approx. 100 m long
- measuring device: DZL363 flowmeter adapter produced by Endress&Hauser; measuring range between 0 – 100 t/h; analogue output signal 4 – 20 mA
- signal transmission: electric wires, approx. 5 m long, analogue signal 4 – 20 mA
- signal conversion device: ISU 24M digital indicator; placed inside the control panel; converts the analogue signal into digital signal; recording period: 2 seconds.
- data recorded into the “data logger” are transmitted through an optic fiber network to a computer designated particularly for this type of monitoring. This computer is located in the Instrumentation Plant. Data are stored in a database on the computer’s hard disk. From this database data are afterwards processed in order to obtain all data necessary for the project. The entire database is periodically saved on graphic and magnetic support as an Excel file.

P. Temperature of produced nitric acid

- the measuring point is located on the column 4 outlet pipe towards the nitric acid storehouse; Coriolis type sensor; operating conditions: $p = 2.5 \text{ bar}$, $t = 40^\circ\text{C}$
- electric signal transmission between the sensor and the transducer: 2-wire cable, approx. 100 m long
- measuring device: DZL363 flowmeter adapter produced by Endress&Hauser; measuring range between $-50 - 200^\circ\text{C}$; analogue output signal 4 – 20 mA
- signal transmission: electric wires, approx. 5 m long, analogue signal 4 – 20 mA
- signal conversion device: ISU 24M digital indicator; placed inside the control panel; converts the analogue signal into digital signal; recording period: 2 seconds.
- data recorded into the “data logger” are transmitted through an optic fiber network to a computer designated particularly for this type of monitoring. This computer is located in the Instrumentation Plant. Data are stored in a database on the computer’s hard disk. From this database data are afterwards processed in order to obtain all data necessary for the project. The entire database is periodically saved on graphic and magnetic support as an Excel file.

Q. Density of produced nitric acid

- the measuring point is located on the column 4 outlet pipe towards the nitric acid storehouse; Coriolis type sensor; operating conditions: $p = 2.5 \text{ bar}$, $t = 40^\circ\text{C}$



- electric signal transmission between the sensor and the transducer: 2-wire cable, approx. 100 m long
- measuring device: DZL363 flowmeter adapter produced by Endress&Hauser; measuring range between 1.2 – 1.4 kg/l; analogue output signal 4 – 20 mA
- signal transmission: electric wires, approx. 5 m long, analogue signal 4 – 20 mA
- signal conversion device: ISU 24M digital indicator; placed inside the control panel; converts the analogue signal into digital signal; recording period: 2 seconds.
- data recorded into the “data logger” are transmitted through an optic fiber network to a computer designated particularly for this type of monitoring. This computer is located in the Instrumentation Plant. Data are stored in a database on the computer’s hard disk. From this database data are afterwards processed in order to obtain all data necessary for the project. The entire database is periodically saved on graphic and magnetic support as an Excel file.

R. Tail gases flow, tail gases pressure, tail gases temperature

- the measuring point is located on the expansion turbine outlet pipe towards the discharge nozzle; Pytot type sensor with multiple holes; operating conditions: absolute $p = 2.5$ bar, $t = 80^{\circ}\text{C}$
- pneumatic connection line (12 mm diameter and approx. 1 m long hoses) between the sensor and the electric switch box where the Dp cell is located; pneumatic connection line (6 mm diameter and approx. 2 m long hose) between the sensor and the electric switch box where the absolute pressure measuring cell is located
- measuring device: Dp differential transducer, produced by ABB, measuring range between 0 – 30 mbar; absolute pressure transducer produced by Endress&Hauser, measuring range between 0 – 0.3 bar; Pt100 thermal resistance with built-in adapter, measuring range between 0 - 200°C ; analogue output signal 4 – 20 mA
- signal transmission: electric wires, approx. 5 m long, analogue signal 4 – 20 mA
- signal conversion device: ISU 24M digital indicator; placed inside the control panel; converts the analogue signal into digital signal; recording period: 2 seconds.
- data recorded into the “data logger” are transmitted through an optic fiber network to a computer designated particularly for this type of monitoring. This computer is located in the Instrumentation Plant. Data are stored in a database on the computer’s hard disk. From this database data are afterwards processed in order to obtain all data necessary for the project. The entire database is periodically saved on graphic and magnetic support as an Excel file.

S. Oxidation reactor pressure

- the measuring point is located on the air compressor discharge pipe; sensor type: capsule for electronic transducer; operating conditions: absolute $p = 3.5$ bar, $t = 200^{\circ}\text{C}$
- pneumatic connection line between the sensor and the transducer; pneumatic connection line of 8 mm diameter and approx. 10 m long
- measuring device: Foxboro transducer, measuring range between 0 – 5 bar; absolute pressure transducer produced by Endress&Hauser, measuring range between 0 – 0.3 bar; Pt100 thermal resistance with built-in adapter, measuring range between 0 - 200°C ; analogue output signal 4 – 20 mA
- signal transmission: electric wires, approx. 50 m long, analogue signal 4 – 20 mA



- signal conversion device: ISU 24M digital indicator; placed inside the control panel; converts the analogue signal into digital signal; recording period: 2 seconds.
- data recorded into the “data logger” are transmitted through an optic fiber network to a computer designated particularly for this type of monitoring. This computer is located in the Instrumentation Plant. Data are stored in a database on the computer’s hard disk. From this database data are afterwards processed in order to obtain all data necessary for the project. The entire database is periodically saved on graphic and magnetic support as an Excel file.

T. N₂O concentration

- the impulse line is the same as the NO_x outlet line
- the circuit is the same as for measuring NO_x outlet concentration, including up to the pressure reducing valve outlet.
- the gas for the N₂O analyzer is taken from here through a water discharge cooler. The analyzer is produced by Environement S.A., France and is based on non-dispersive infrared absorption principle; it is placed in the same cabinet as the NO_x analyzer. The N₂O concentration measurement range is between 0 – 2000 ppm.
- the outlet analyzer signal is of 4 – 20 mA, proportional to the value of the concentration. This signal is transmitted through an electric cable at the plant’s central control panel. The electric cable is approx. 100 m long.
- the device that converts the 4 – 20 mA signal in nitrogen oxides concentration is a ISU – MMC- 24C digital indicator produced by Infostar Pascani. The device has 16 inlet circuits of 4 – 20 mA. The readings are digitally displayed and are recorded every 2 seconds. Data recorded into the “data logger” are transmitted through an optic fiber network to a computer designated particularly for this type of monitoring. This computer is located in the Instrumentation Plant. Data are stored in a database on the computer’s hard disk. From this database data are afterwards processed in order to obtain all data necessary for the project. The entire database is periodically saved on graphic and magnetic support as an Excel file.