

JI MONITORING REPORT FORM

Monitoring Report #6 "Utilization of Coal Mine Methane at the Coal Mine named after A.F. Zasyadko" page 1

JI MONITORING REPORT ANNUAL REPORT

**Version 2.2
4 December 2009**

CONTENTS

- A. General project activity and monitoring information
- B. Key monitoring activities
- C. Quality assurance and quality control measures
- D. Calculation of GHG emission reductions

JI MONITORING REPORT FORM

Monitoring Report #6 "Utilization of Coal Mine Methane at the Coal Mine named after A.F. Zasyadko" page 2

SECTION A. General Project activity information

A.1 Title of the project activity:

"Utilization of Coal Mine Methane at the Coal Mine named after A.F. Zasyadko".

A.2. Registration number at JISC:

UA2000004

A.3. Short description of the project activity:

According to data of the mine the following amount of methane was utilized during nine months year 2009:

For electricity (and heat) m ³ (fuel gas)	27 366 838
For electricity (and heat) m ³ (ignition gas)	1 106 628
For AGFCP m ³	1 329 458
Total	29 802 978

Table 1: Amount of methane utilized during monitoring period.

The project is aimed to prevent emission of methane into atmosphere at Lease Enterprise Zasyadko Coal Mine, further referred to as Zasyadko or simply Mine. CMM extracted and recovered during mine works and as a result of ventilation of Mine, obtained from surface wells drilled into the gob at Zasyadko Coal Mine, is utilized for:

- Power production;
- Replacement of heat that is now generated by coal and gas boilers;
- Production of gas for motor vehicle fuelling.

Mine has four industrial sites: Vostochnaya, Yakovlevskaya, Centralnaya and Grigoryevskaya. During this monitoring period, one CHP at Vostochnaya site was in operation. The power generated at CHP was supplied in Mine's main, for Mine's local consumption. Heat generated by Vostochnaya CHP was feed for consumption at Vostochnaya site. Double-block automatic gas filling station at Vostochnaya site supply car fleet of Mine and other vehicles from neighbouring districts with fuel.

In the future, commissioning of the second CHP at Yakovlevskaya site is intended, and heat supply grid as well. This will make Mine able to feed excess power to general consumption grid, supply heat to Vostochnaya, Yakovlevskaya, and Centralnaya sites, and municipal heat supply grid. Besides, gas fuelling stations will be installed at Yakovlevskaya site.

A.4. Monitoring period:

- Monitoring period starting date: 01/01/2009;
- Monitoring period closing date: 30/09/2009.¹

A.5. Methodology applied to the project activity (incl. version number):

A.5.1. Baseline methodology: The approved consolidated methodology ACM0008/Version 03 "Consolidated baseline methodology for coal bed methane and coal mine methane capture and use for power (electrical or motive) and heat and/or destruction by flaring") has been used to identify the baseline scenario of this JI project. This methodology also refers to the "Tool for calculation of emission factor for electricity systems", the latest version of the "Tool for the demonstration and assessment of additionality" and the latest version of the "Tool to determine project emissions from flaring gases containing methane".

A.5.2. Monitoring methodology: The approved consolidated methodology ACM0008/Version 03 "Consolidated baseline methodology for coal bed methane and coal mine methane capture and use for power (electrical or motive) and heat and/or destruction by flaring") has been used to identify the baseline scenario of this JI project.

¹ Both days were included Monitoring period includes time from 00-00 01/01/09 up to 24-00 30/09/09.

JI MONITORING REPORT FORM

Monitoring Report #6 “Utilization of Coal Mine Methane at the Coal Mine named after A.F. Zasyadko” page 3

A.6. Status of implementation including time table for major project parts:

Activity	Date
Commissioning of blocks (No.1, No.2) at gas filling compressor stations at Vostochnaya site	March 2004
Commissioning of new block No.3 at gas filling compressor station at Vostochnaya site	March 2005
Commissioning of the 1 st CHP modules at Vostochnaya site	January 2006
Commissioning of the 12 th CHP modules at Vostochnaya site	April 2006
Shut-down of boilers at Vostochnaya site	September 2006
Construction of vacuum pump station N 4 at Grigoryevskaya shaft with six vacuum pumps VVN-150 and build up 3 pipe lines	March 2007
Heat feeding from CHP units to, and shutdown of the boilers at Grigoryevskaya site	December 2011
Heat feeding from CHP units to, and shutdown of the boilers at Yakovlevskaya site	October 2010
Commissioning of the 1 st CHP unit at Yakovlevskaya site	December 2010
Commissioning of 6 CHP units at Yakovlevskaya site	December 2011
Heat supply to district heat supply system	December 2012

Table 2: Status of implementation (according to PDD version 4.4)

A.7. Intended deviations or revisions to the registered PDD:

There are no deviations from final version of PDD approved by JISC. A delay in the implementation schedule was noted as compared with implementation schedule from PDD as shown above. In view of this, within the monitoring period, following project parts were not introduced:

- Power: Yakovlevskaya CHP is not in operation at this moment. At this CHP, power generation is not running; as a result, GEN_{CHP} includes only net power generated by Vostochnaya CHP;
- Heat: during this monitoring period, infrastructure for heat supply of four sites of Mine and municipal heat supply grid are absent, save heat supply from Vostochnaya CHP to Vostochnaya site. In view of this, at this monitoring period, monitoring of following variable data was not performed: $HEAT_{deliv, DH, y}$; $HEAT_{deliv, yak, y}$; $HEAT_{deliv, centr, y}$. General amount of heat supplied is equal to amount of heat supplied from Vostochnaya CHP ($HEAT_{deliv, vost, y}$);
- Coal Mine Methane (CMM), utilized at CHP: As Yakovlevskaya CHP was not in operation during this monitoring period, CMM was not utilized at this CHP. Therefore, $MM_{CHP, y}$ included only CMM, utilized by Vostochnaya CHP;
- Coal Mine Methane (CMM) utilized at AGFCP. From five planned fuel stations (one- at Vostochnaya site, one- at Centralnaya site, and two- on Yakovlevskaya site), during this monitoring period, two block gas filling stations at Vostochnaya site and one- at Centralnaya site have been operated. Therefore for $MM_{GAS, y}$ monitoring, only gas supply to these gas fueling stations was used.

A.8. Intended deviations or revisions to the registered monitoring plan (Decision 17/CP.7, Annex H, paragraph 57 to be considered):

There are no deviations in the monitoring plan compared to the final monitoring plan dd. 27 March 2008 as described in the PDD version 4.4. Below –mentioned metering devices have been substituted, and additions have been made to provide safety of parameters monitored. Calibration of all these devices has been performed (see below). Parameters as well as formulas have not been changed.

From January 1 2008, following metering devices have been added/ substituted:

First and second line metering devices have been substituted, as metering system at CHP units was renewed and improved. Additionally, new metering device blocks to meter high concentration methane have been installed:

JI MONITORING REPORT FORM

Monitoring Report #6 "Utilization of Coal Mine Methane at the Coal Mine named after A.F. Zasyadko" page 4

- Universal 1 Metering system for ignition gas at CHP unit instead of Gn6 with their sensors;
- Universal 2 Metering system for fuel gas at AGFCP, additionally to gas fuelling stations equipment;
- BKTМ Metering system for fuel gas in machine rooms, instead of Keuter device, ADM Electronic at gas treatment facility.

See more detailed description of layout and work of metering equipment in Section B.

A.9. Changes since last verification:

During 01/01/2009-30/09/2009, no changes occurred since last verification

A.10. Person(s) responsible for the preparation and submission of the monitoring report:

Lease enterprise "Coal Mine named after A.F. Zasyadko"

- Boris Bokiу, Deputy General Director
- Yevgeniy Berezovskiy, CHP Chief;
- Valeriy Cherednikov, Monitoring Engineer, Gas Treatment Lead Engineer;

Carbon Emission Partnership LLC.

- Sergiy Apostolaka, Director.

SECTION B. Key monitoring activities according to the monitoring plan for the monitoring period stated in A.4.

The control and monitoring system can be divided into an electrical part, a heat part and a gas part.

Electrical measurements

There are no changes since last monitoring period.

Heat measurements

There are no changes since last monitoring period.

B.1. Monitoring equipment types

There are no changes since last monitoring period.

1. Electricity meters "Elster-Metronika"
2. Heat meter SA-94/2 M
3. Gas Analyzer ABB A02040 (for fuel and ignition methane)
4. DBT equipment. (for fuel and ignition methane)
5. DRGM flow meters (for fuel methane) as a part of BKTМ metering systems.
6. Metering system "Universal"

B.1.2. Table providing information on metering equipment used (incl. manufacturer, type, serial number, date of installation, Date of calibration, information to specific uncertainty, need for changes and replacements):

The control and monitoring system can be divided into an electrical part, a heat part, and a gas part.

Electrical measurements

JI MONITORING REPORT FORM

Monitoring Report #6 “Utilization of Coal Mine Methane at the Coal Mine named after A.F. Zasyadko” page 5

Since the last monitoring period, at 110 kV substation, on 04.03.09 current transformers 1000/5 have been substituted by 150/5 (see below diagram before and after that, with electrical meters indicated). Also on 25.03.09, because of this change, commercial electricity meters had to be substituted. Electricity meter EA-02RAL-P3C-3 have been substituted for electricity meters EA-02RAL-P2C-4W.

Following parameters shall be measured for emission reduction monitoring²:

- GEN_{CHP} — net electricity generated by CHP under project(MWh);
- EL_{cons} — net electricity consumed by Mine (MWh)³.

According to monitoring plan, initially excess or lack of net electricity amount was checked as generated by CHP in comparison to net electricity consumed by Mine. Actually, parameters measured are:

- $GEN_{CHP} = 95\ 656.884$ MWh;
- $EL_{cons} = 137\ 865.158$ MWh.

As net electricity amount generated by CHP under project is less than net electricity consumed by Mine, for emission reduction monitoring (see also page 40 of PDD), only amount of electricity generated by CHP is required. Net electricity generated by CHP is measured with two meters in power grid of Mine:

$$GEN_{CHP} (MWh) = E1 + E2 \tag{1.}$$

To perform cross-checking, electricity generated by CHP is summed up by way of addition of total electricity amount generated by each separate CHP unit excluding secondary electricity consumption by CHP itself. This calculation is performed under following formula.

$$GEN_{CHP} = \left(\sum_5^{16} E_{mod} - \sum_3^4 E_{aux} \right) = (E5 + E6 + E7 + E8 + E9 + E10 + E11 + E12 + E14 + E15 + E16) - (E3 + E4) \tag{2.}$$

Respective description of meters see in the table provided below. Because for check of electricity at high voltage, it is impossible to use data directly from meters, current and voltage transformers are used. In the first table, converted data for calculation of actual data are shown.

² Section D contains respective formulae from Monitoring Plan of PDD.

³ Net electricity consumption of Mine is demonstrated in the report of Chief Energy Engineer of the Mine according to data of thirteen commercial meters located at other 110 kV substations.

JI MONITORING REPORT FORM

Monitoring Report #6 “Utilization of Coal Mine Methane at the Coal Mine named after A.F. Zasyadko” page 6

Electricity Meters

Number	Metering instrument	Work parameter kWh, kVar	Manufacturer	Type	Serial Number	Accuracy	Date of installation	Data 01.01.2009	Data 30.09.2009	Difference	Date of calibration	Date of next calibr.	Remarks
E1	Electricity meter at CHP system (6 kV) Wireway	Net electricity generated by CHP system. P,Q	“Elster-Metronika” Russia	Electronic	01116374	0.2 S	N/A	5327.0361	6468,9487	1141,9126	14.05.2005	2-nd Quarter 2011	Double side. Cubicle No.A21
E2	Electricity meter at CHP system (6 kV) Wireway	Additional electricity generated by CHP system. P,Q	“Elster-Metronika” Russia	Electronic	01116376	0.2 S	N/A	5432.8103	6821,5027	1388,6924	14.05.2005	2-nd quarter 2011	Double side. Cubicle No.B22
E17 ⁴	Commercial electricity meter 110 kV	Consumption of electricity from or supply Ukrainian grid with	“Elster-Metronika” Russia	Electronic	№ 1116378 (till 25.03.09) 01194835 (after 25.03.09)	0.2 S	N/A	See table below (page 10)			N/A Belongs to supply company	N/A	Substation 110kV T1
E18 ⁴	Commercial electricity meter 110 kV	Consumption of electricity from or supply Ukrainian grid with	“Elster-Metronika” Russia	Electronic	№ 1116380 (till 25.03.09) 01194834 (after 25.03.09)	0.2 S	N/A	See table below (page 10)			N/A Belongs to supply company	N/A	Sub-station 110kV T1

⁴ In view of substitution at substation on 04.03.09 of current transformers 1000/5 for 150/5, electrical power calculation rate has been changed; electrical meters have been also substituted, thus, for E17 and E18 are included in additional table, under consideration of changes.

JI MONITORING REPORT FORM

Monitoring Report #6 “Utilization of Coal Mine Methane at the Coal Mine named after A.F. Zasyadko” page 7

Num ber	Metering instrument	Work parameter kWh, kVar	Manufacturer	Type	Serial Number	Accu- racy	Date of instal- lation	Data 01.01.2009	Data 30.09.2009	Diffe- rence	Date of calibratio n	Date of next calibr.	Remarks
E3	Electricity meter at CHP system (6 kV) Auxiliary transformer	Electricity consumed by CHP system, P, Q	“Elster- Metronika” Russia	Electr- onic	№01103251	0.2 S	N/A	2804.6062	3459,6690	655,0628	03.09.2004	03.09.2010	Cubicle No.1
E4	Electricity meter at CHP system (6 kV) Auxiliary transformer	Electricity consumed by CHP system, P, Q	“Elster- Metronika” Russia	Electr- onic	№01103208	0.2 S	N/A	2115.038	3576,4570	598,6007	03.09.2004	03.09.2010	Cubicle No.2
E5	Electricity meters at individual CHP modules (6 kV) No.1	Gross electricity generated by CHP system P,Q	“Elster- Metronika” Russia	Electr- onic	№01117846	0.2 S	N/A	3325.768	7279,1460	1924,6488	16.06.2005	16.06.2011	Double side. Cubicle No.5
E6	Electricity meters at individual CHP modules (6 kV) No.3	Gross electricity generated by CHP system P,Q	“Elster- Metronika” Russia	Electr- onic	№01117849	0.2 S	N/A	6366.4029	8197,4910	1831.0881	16.06.2005	16.06.2011	Double side. Cubicle No.7
E7	Electricity meters at individual CHP modules (6 kV) No.5	Gross electricity generated by CHP system P,Q	“Elster- Metronika” Russia	Electr- onic	№01117851	0.2 S	N/A	7009.7556	8758,3080	1748,5524	16.06.2005	16.06.2011	Double side. Cubicle No.9
E8	Electricity meters at individual CHP modules (6 kV) No.7	Gross electricity generated by CHP system P,Q	“Elster- Metronika” Russia	Electr- onic	№01117852	0.2 S	N/A	7076.2119	8286,1090	1209,8971	16.06.2005	16.06.2011	Double side. Cubicle No.11
E9	Electricity meters at individual CHP modules (6 kV) No.9	Gross electricity generated by CHP system P,Q	“Elster- Metronika” Russia	Electr- onic	№01117855	0.2 S	N/A	7586.0212	9582,9110	1996,8898	16.06.2005	16.06.2011	Double side. Cubicle No.13
E10	Electricity meters at individual CHP modules (6 kV) No.11	Gross electricity generated by CHP system P,Q	“Elster- Metronika” Russia	Electr- onic	№01117856	0.2 S	N/A	7062.2035	9139,1590	2076,9555	16.06.2005	16.06.2011	Double side. Cubicle No.15

JI MONITORING REPORT FORM

Monitoring Report #6 “Utilization of Coal Mine Methane at the Coal Mine named after A.F. Zasyadko” page 8

Number	Metering instrument	Work parameter kWh, kVar	Manufacturer	Type	Serial Number	Accuracy	Date of installation	Data 01.01.2009	Data 30.09.2009	Difference	Date of calibration.	Date of next calibr.	Remarks
E11	Electricity meters at individual CHP modules (6 kV) No.2	Gross electricity generated by CHP system P,Q	“Elster-Metronika” Russia	Electr-onic	№01117848	0.2 S	N/A	7612,8447	9854.3730	2241.5283	16.06.2005	16.06.2011	Double side. Cubicle No.6
E12	Electricity meters at individual CHP modules (6 kV) No.4	Gross electricity generated by CHP system P,Q	“Elster-Metronika” Russia	Electr-onic	№01122645	0.2 S	N/A	4865,2848	4987.9100	122.6251	10.08.2005	10.08.2011	Double side. Cubicle No.8
E13	Electricity meters at individual CHP modules (6 kV) No.6	Gross electricity generated by CHP system P,Q	“Elster-Metronika” Russia	Electr-onic	№01122650	0.2 S	N/A	6507,4503	8475.1990	1967.7487	10.08.2005	10.08.2011	Double side. Cubicle No.10
E14	Electricity meters at individual CHP modules (6 kV) No.8	Gross electricity generated by CHP system P,Q	“Elster-Metronika” Russia	Electr-onic	№01117845	0.2 S	N/A	8179,9092	10390.0020	2210.0928	16.06.2005	16.06.2011	Double side. Cubicle No.12
E15	Electricity meters at individual CHP modules (6 kV) No.10	Gross electricity generated by CHP system P,Q	“Elster-Metronika” Russia	Electr-onic	№01132765	0.2 S	N/A	7574,2747	9796.8460	2222.5713	09.02.2006	09.02.2012	Double side. Cubicle No.14
E16	Electricity meters at individual CHP modules (6 kV) No.12	Gross electricity generated by CHP system P,Q	“Elster-Metronika” Russia	Electr-onic	№01132766	0.2 S	N/A	6101,1777	6238.0600	136.8823	09.02.2006	09.02.2012	Double side. Cubicle No.16

Calibration interval for electricity meters is six years.

JI MONITORING REPORT FORM

Monitoring Report #6 "Utilization of Coal Mine Methane at the Coal Mine named after A.F. Zasyadko" page 9

Number	Data 01.01.2009	Data 04.03.2009	Difference	Re-calculation ratio	Electricity amount	Data 04.03.2009	Data 25.03.2009	Difference	Re-calculation ratio	Electricity amount	Data 25.03.2009	Data 30.09.2009	Difference	Electricity amount	Σ Electricity amount
E17	303.7310	307.1820	3.451	220000	759 220	307.182	308.183	1.001	33000	33 033	0.0	98,126	98,126	3 238 158	4 030 411
E18	308.5050	308.9020	0.397	220000	87 340	308.902	316.097	7.195	33000	237 435	0.0	57,760	57,760	1 906 080	2 230 855

As it is impossible to use meters data directly to check electricity generated we have to take in account special coefficients which is appears from multiplying of coefficients transformation for current and voltage transformers connected to each meter. Their data are presented in table below.

In view of high voltage and currents, it is impossible to obtain direct data from electricity meters on generation and consumption of electricity without current and voltage transformers, for accounting of equipment operation. The calculation method is following: example for meter No.№ 01116374: Current $-3000/5= 600$ A; voltage- $6300/100=63$ V (gross factor $-600 \times 63 =37800$ VA). Data on meter -1141.9126. Electricity to be accounted with this meter makes up: $1141.9126 \times 600 \times 63=43\ 164\ 296,3$ VA =43 164 296.3 kW

JI MONITORING REPORT FORM

Monitoring Report #6 "Utilization of Coal Mine Methane at the Coal Mine named after A.F. Zasyadko" page 10

Number	Metering instrument	Work parameter kWh, kVar	Type	Serial Number	Current transformer	Voltage transformer	Coefficient for calculations	Electricity Amount
E1	Electricity meter at CHP system (6 kV) Wireway	Net electricity generated by CHP system. P,Q	Electronic	01116374	3000/5	6300/100	37800	43 164 296,3
E2	Electricity meter at CHP system (6 kV) Wireway	Net electricity generated by CHP system. P,Q	Electronic	01116376	3000/5	6300/100	37800	52 492 572,7
E3	Electricity meter at CHP system (6 kV) Auxiliary transformer	Electricity consumed by CHP system, P, Q	Electronic	01103251	200/5	6300/100	2520	1 650 758,3
E4	Electricity meter at CHP system (6 kV) Auxiliary transformer	Electricity consumed by CHP system, P, Q	Electronic	01103208	200/5	6300/100	2520	1 508 473,8
E5	Electricity meters at individual CHP modules (6 kV) No.1	Gross electricity generated by CHP system P,Q	Electronic	01117846	400/5	6300/100	5040	9 700 230,0
E6	Electricity meters at individual CHP modules (6 kV) No.3	Gross electricity generated by CHP system P,Q	Electronic	01117849	400/5	6300/100	5040	9 228 684,0
E7	Electricity meters at individual CHP modules (6 kV) No.5	Gross electricity generated by CHP system P,Q	Electronic	01117851	400/5	6300/100	5040	8 812 704,1
E8	Electricity meters at individual CHP modules (6 kV) No.7	Gross electricity generated by CHP system P,Q	Electronic	01117852	400/5	6300/100	5040	6 097 881,4
E9	Electricity meters at individual CHP modules (6 kV) No.9	Gross electricity generated by CHP system P,Q	Electronic	01117855	400/5	6300/100	5040	10 064 324,6
E10	Electricity meters at individual CHP modules (6 kV) No.11	Gross electricity generated by CHP system P,Q	Electronic	01117856	400/5	6300/100	5040	10 467 855,7
E11	Electricity meters at individual CHP modules (6 kV) No.2	Gross electricity generated by CHP system P,Q	Electronic	1117848	400/5	6300/100	5040	11 297 302,6
E12	Electricity meters at individual CHP modules (6 kV) No.4	Gross electricity generated by CHP system P,Q	Electronic	01122645	400/5	6300/100	5040	618 030,5

JI MONITORING REPORT FORM

Monitoring Report #6 "Utilization of Coal Mine Methane at the Coal Mine named after A.F. Zasyadko" page 11

Number	Metering instrument	Work parameter kWh, kVar	Type	Serial Number	Current transformer	Voltage transformer	Coefficient for calculations	Electricity Amount
E13	Electricity meters at individual CHP modules (6 kV) No.6	Gross electricity generated by CHP system P,Q	Electronic	01122650	400/5	6300/100	5040	9 917 453,4
E14	Electricity meters at individual CHP modules (6 kV) No.8	Gross electricity generated by CHP system P,Q	Electronic	01117845	400/5	6300/100	5040	11 138 867,7
E15	Electricity meters at individual CHP modules (6 kV) No.10	Gross electricity generated by CHP system P,Q	Electronic	01132765	400/5	6300/100	5040	11 201 759,4
E16	Electricity meters at individual CHP modules (6 kV) No.12	Gross electricity generated by CHP system P,Q	Electronic	01132766	400/5	6300/100	5040	689 886,8
E17	Commercial electricity meter 110 kV	Consumption of electricity from or supply Ukrainian grid with	See table above (page 10)					
E18	Commercial electricity meter 110 kV	Consumption of electricity from or supply Ukrainian grid with	See table above (page 10)					

JI MONITORING REPORT FORM

Monitoring Report #6 “Utilization of Coal Mine Methane at the Coal Mine named after A.F. Zasyadko” page 12

Electricity Metering Scheme for Vostochnaya CHP Facility

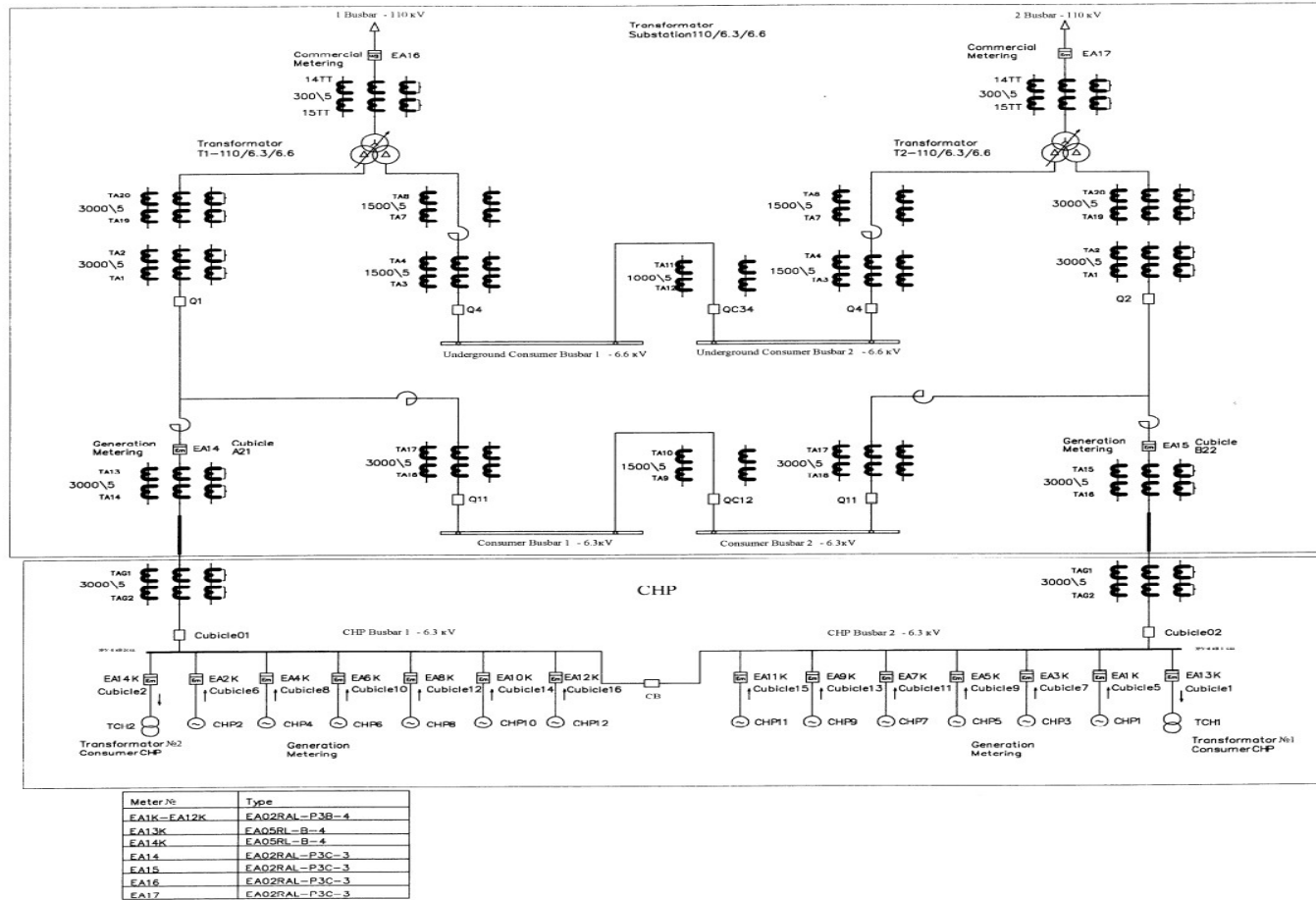

Figure 1: Electricity Metering Scheme for Vostochnaya CHP Facility before changes put on 04.03.2009

JI MONITORING REPORT FORM

Monitoring Report #6 “Utilization of Coal Mine Methane at the Coal Mine named after A.F. Zasyadko” page 13

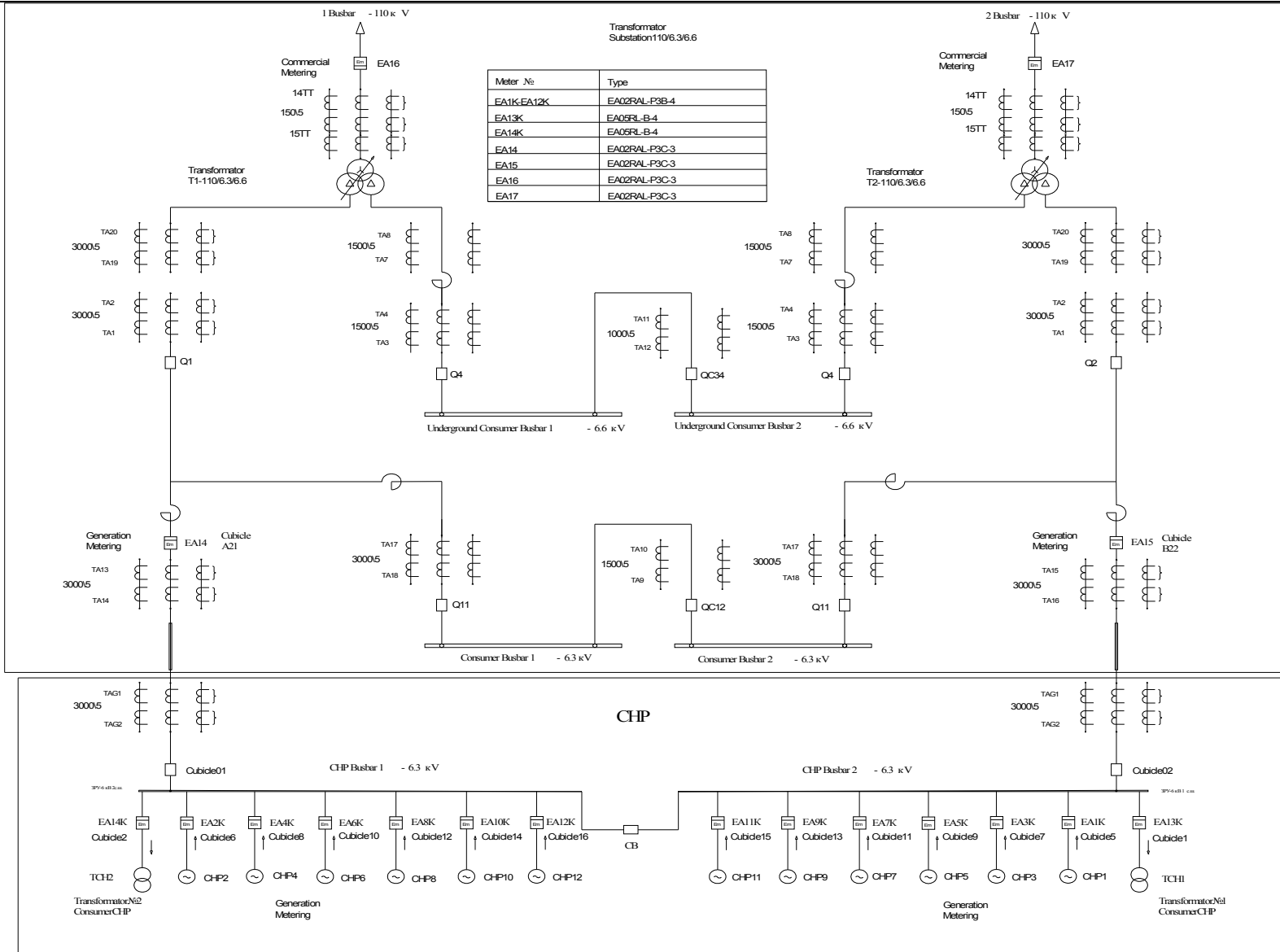

Figure 2: Electricity Metering Scheme for Vostochnaya CHP Facility after changes put on 04.03.2009

JI MONITORING REPORT FORM

Monitoring Report #6 "Utilization of Coal Mine Methane at the Coal Mine named after A.F. Zasyadko" page 14

Heat Meter

Heat measurements

For this monitoring period, only heat is considered that was directly fed by Vostochnaya CHP, as described in paragraph A.7. Therefore, for this monitoring period, only one variable is measured that expresses heat amount fed by CHP system to heat supply pipelines, and is equal to heat amount consumed by Vostochnaya site.

Metering instrument	Work parameter GCal	Manufacturer	Type	Serial number	accuracy	Date of installation	Data 01.01.2009 Gcal	Data 30.09.2009 Gcal	Difference	Date of calibration	Date of next calibr.	Remarks
Heat meter SA 94/2M ⁵	Amount of heat delivered to site system	ASWEGA	Mechatronic	22903	Heat- 4 Flow-2	N/A	69815.39	95238,83	25 423,44	04.06.07 04.06.09	04.06.1 1	T,V,Q (Total)

Calibration interval for heat meters is two years

⁵For meter SA 94/2M DN=300mm; Q=1000m³/h

JI MONITORING REPORT FORM

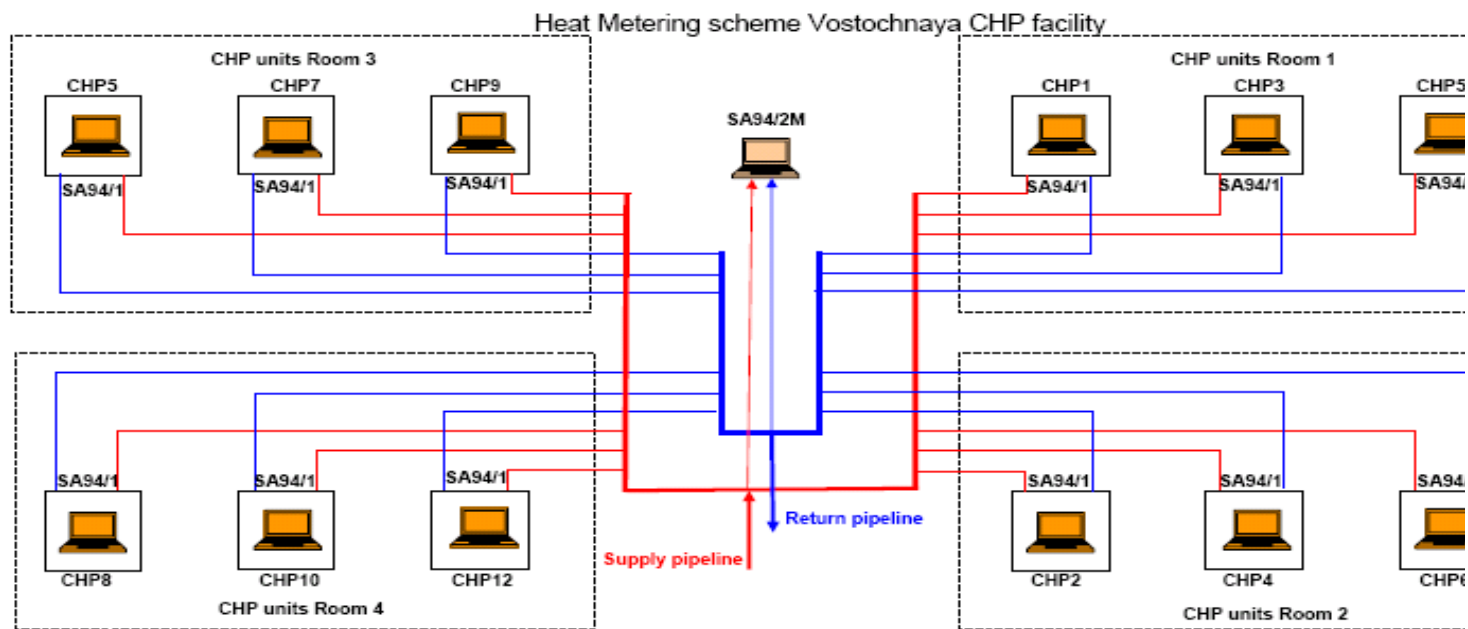

Figure3: Heat Metering Scheme for Vostochnaya CHP Facility

JI MONITORING REPORT FORM

Monitoring Report #6 “Utilization of Coal Mine Methane at the Coal Mine named after A.F. Zasyadko” page 16

CMM Meters

Measurement of CMM consumption

According to monitoring plan, two variables are measured:

MM_{CHP}- measured amount of methane fed to CHP units (tCH₄);

MM_{GAS}- measured amount of methane fuelled in vehicles at new automotive gas filling stations (tCH₄).

Variable MM_{CHP} has two components: fuel gas consumption and ignition gas consumption. To determine the amount of pure consumed CH₄ (in tonnes) the amount of pure CH₄ (in m³) has to be measured under normal conditions⁶.

The amount of pure CH₄ (in m³) can be measured (or more correctly: calculated) based on four parameters:

- Concentration (%) of CH₄ in the gas mixture
- Flow (m³) of gas mixture
- Temperature (C) of gas mixture
- Pressure (bar) of gas mixture

In the scheme below the different meters and sensors are indicated that are installed at the Vostochnaya site. We can classify the different meters/sensors:

- Scheme of location of main primary meters/sensors that supply the data for determining the emission reductions as provided in section D of the Monitoring Report;
- General scheme of location of meters/sensors (with addition of secondary meters/ sensors) used for cross-checking the data of the primary meters, as well as meters/sensors used to operated and control the installation.

The secondary meters/sensors are not of interest for monitoring purposes and are not mentioned further. In the table below the primary and secondary meters/sensors are indicated with their number which listed in the scheme.

	Primary meters/sensors	Secondary meters/sensors
Fuel gas		
Concentration (%)	ABB AO 2040 (A1)	K1-K6
Flow (V)	G1-G12	Gn1-Gn6
Temperature (T)	T6-T17	Gn5 sensor
Pressure (P)	P11-P22	P6(Gn5's sensor)
Unit for methane keeping (m3)	BKT.M ⁷ metering system	DBT equipment
Ignition gas		
Concentration (%)	ABB AO 2040 (A2)	ABB AO 2040 (A2)
Flow (V)	G13	
Temperature (T)	T2	
Pressure (P)	P10	
Unit for methane keeping (m3)	"Universal" ⁸ metering system	Pressure sensors on pipeline
AGFCP gas		
Concentration (%)	ABB AO 2040 (A2)	ABB AO 2040 (A2)
Flow (V)	G14	Calculations according to pressure difference
Temperature (T)	T1	
Pressure (P)	P5	Manometers at AGFCS
Unit for methane keeping (m3)	"Universal" ⁸ metering system	Calculations

Table 3: Primary and secondary (cross-checking) metering of CMM

⁶ Normal conditions=273K and 760 mm Hg.

⁷ BKT.M is designed for conversion of input data of gas parameters and calculation on the base thereof of amount and volumetric gas flow brought to standard conditions, in the composition of DRG.M meter.

⁸ Universal is designed for conversion of input data of gas parameters and calculation on the base thereof of amount and volumetric gas flow brought to standard conditions.

MM_{CHP} – is an amount of fuel gas consumption at each CHP unit, including one ignition gas metering device, represented as following:

JI MONITORING REPORT FORM

Monitoring Report #6 "Utilization of Coal Mine Methane at the Coal Mine named after A.F. Zasyadko" page 17

$$MM_{\text{CHP}} = \left(\sum_1^{12} VM_n \cdot xC_1 + V_1 \cdot xC_2 \right) \cdot 0,7167 \cdot 0,93, \quad (3.)$$

where:

VM_n — fuel gas consumption by separated CHP unit, brought to standard ⁹ conditions (m³);

$C_{1,2}$ —CH₄ concentration sensors (%);

V_1 — amount of methane fed as ignition gas (m³);

0.7167 — methane density in normal conditions (kg/m³);

0.93- - standard conditions to normal conditions conversion ratio

Fed MM_{GAS} to be measured as following:

$$MM_{\text{GAS}} = V_2 \cdot C_2 \cdot 0,7167 \cdot 0,93, \quad (4.)$$

where:

V_2 — amount of methane fed as fuel for vehicles, in standard conditions (m³);

C_2 —CH₄ concentration sensor (%);

0.7167-methane density in normal conditions (kg/m³);

0.93- standard conditions to normal conditions conversion ratio

Sensors represented in tables, shown after general description of methane consumption process.

Crosschecking

Amount of methane used as fuel gas for CHP units undergoes crosschecking. This operation is performed by way of measurement of total amount of gas consumption (m³), that is defined by flow meter который Gn5 (Keuter), which has structure as block of velocity, pressure and temperature sensors that measure amount of gas consumed by CHP units and data on methane concentration in point A1 with gas analyzer AO 2040 (ABB). Amount of methane to be calculated on the base of these data, but it is not used for database formation; it is used only for technological purposes and for crosschecking and control of CHP operation systems. This procedure is carried out on regular basis. Summary results of the internal cross checkings from 2009 year are presented in the table 3.1.

Table 3.1. Summary results of internal cross checking, January - September 2009

Month	Q Fuel Gas Consumption, m3/month Gn5	F Fuel Gas, Net Consumption, m3/month Gn5 * CH4/100	Q Fuel Gas, Net Consumption, m3/month ∑ BKT.M1-BKT.M4	Relative Difference in Readings Gn5*CH4/100 and ∑ BKT.M1- BKT.M4, %
January	10 697 456,24	3 121 274,45	3 133 396,13	-0,39
February	9 364 479,91	2 592 534,48	2 595 065,21	-0,10
March	10 704 587,06	2 989 549,68	3 014 877,66	-0,84
April	10 162 802,18	2 797 403,14	2 793 942,46	0,12
May	8 871 925,28	2 480 872,98	2 558 086,38	-3,02
June	7 219 945,01	2 143 125,74	2 129 622,54	0,63
July	11 472 211,25	3 291 685,19	3 288 665,48	0,09
August	16 366 850,72	4 781 487,42	4 785 898,88	-0,09
September	11 105 224,52	3 068 852,38	3 067 283,50	0,05
Total	95 965 482,17	27 266 785,47	27 366 838,24	-0,37

⁹ Standard conditions=293K and 760 mm Hg.

Table 3.2. Detailed results of the internal cross checking from September 2009 year

September 2009

JI MONITORING REPORT FORM

Monitoring Report #6 "Utilization of Coal Mine Methane at the Coal Mine named after A.F. Zasyadko" page 18

Day	Q Fuel Gas Consumption, m3/day	F Fuel Gas, Net Consumption, m3/day	Q Fuel Gas, Net Consumption, m3/day	Relative Difference in Readings Gn5*CH4/100 and %
	<i>Gn5</i>	<i>Gn5 * CH4/100</i>	$\sum BKT.M1-BKT.M4$	$\sum BKT.M1- BKT.M4$
01.09.2009	463 860,47	129 742,33	129 309,56	0,33
02.09.2009	411 716,39	112 136,54	111 490,45	0,58
03.09.2009	369 796,03	103 301,60	102 715,72	0,57
04.09.2009	435 266,16	118 243,18	117 836,67	0,34
05.09.2009	424 511,86	117 341,47	116 780,53	0,48
06.09.2009	405 249,89	109 926,25	109 380,59	0,50
07.09.2009	330 153,77	92 736,33	92 051,51	0,74
08.09.2009	313 265,09	84 899,78	85 238,98	-0,40
09.09.2009	321 562,80	86 748,19	86 173,22	0,67
10.09.2009	332 365,27	89 783,78	89 909,06	-0,14
11.09.2009	368 876,18	100 322,22	100 286,09	0,04
12.09.2009	391 248,49	111 973,94	112 547,14	-0,51
13.09.2009	410 509,92	116 320,43	116 497,08	-0,15
14.09.2009	351 811,90	95 088,49	94 875,73	0,22
15.09.2009	343 645,38	93 654,86	93 799,66	-0,15
16.09.2009	361 512,87	99 243,67	99 665,96	-0,42
17.09.2009	370 952,79	101 944,92	102 095,07	-0,15
18.09.2009	394 684,59	110 805,56	110 959,04	-0,14
19.09.2009	398 006,81	113 055,95	113 564,71	-0,45
20.09.2009	365 575,41	105 215,28	105 696,31	-0,46
21.09.2009	358 697,81	97 843,66	97 881,39	-0,04
22.09.2009	325045,64	88724,66	89 377,63	-0,73
23.09.2009	308270,48	85056,62	85 452,65	-0,46
24.09.2009	362931,21	99535,29	98 788,47	0,76
25.09.2009	361 454,46	99 951,09	99 458,25	0,50
26.09.2009	372 529,38	102 768,68	102 335,86	0,42
27.09.2009	349 036,01	98 509,03	98 944,79	-0,44
28.09.2009	337 380,70	92 422,54	92 664,62	-0,26
29.09.2009	351 377,34	97 573,48	97 842,09	-0,27
30.09.2009	413 929,41	113 982,57	113 664,67	0,28
Total	11 105 224,52	3 068 852,38	3 067 283,50	0,05

JI MONITORING REPORT FORM

Monitoring Report #6 “Utilization of Coal Mine Methane at the Coal Mine named after A.F. Zasyadko” page 19

Scheme of location of main meters /sensors at Vostochnaya CHP in 2009

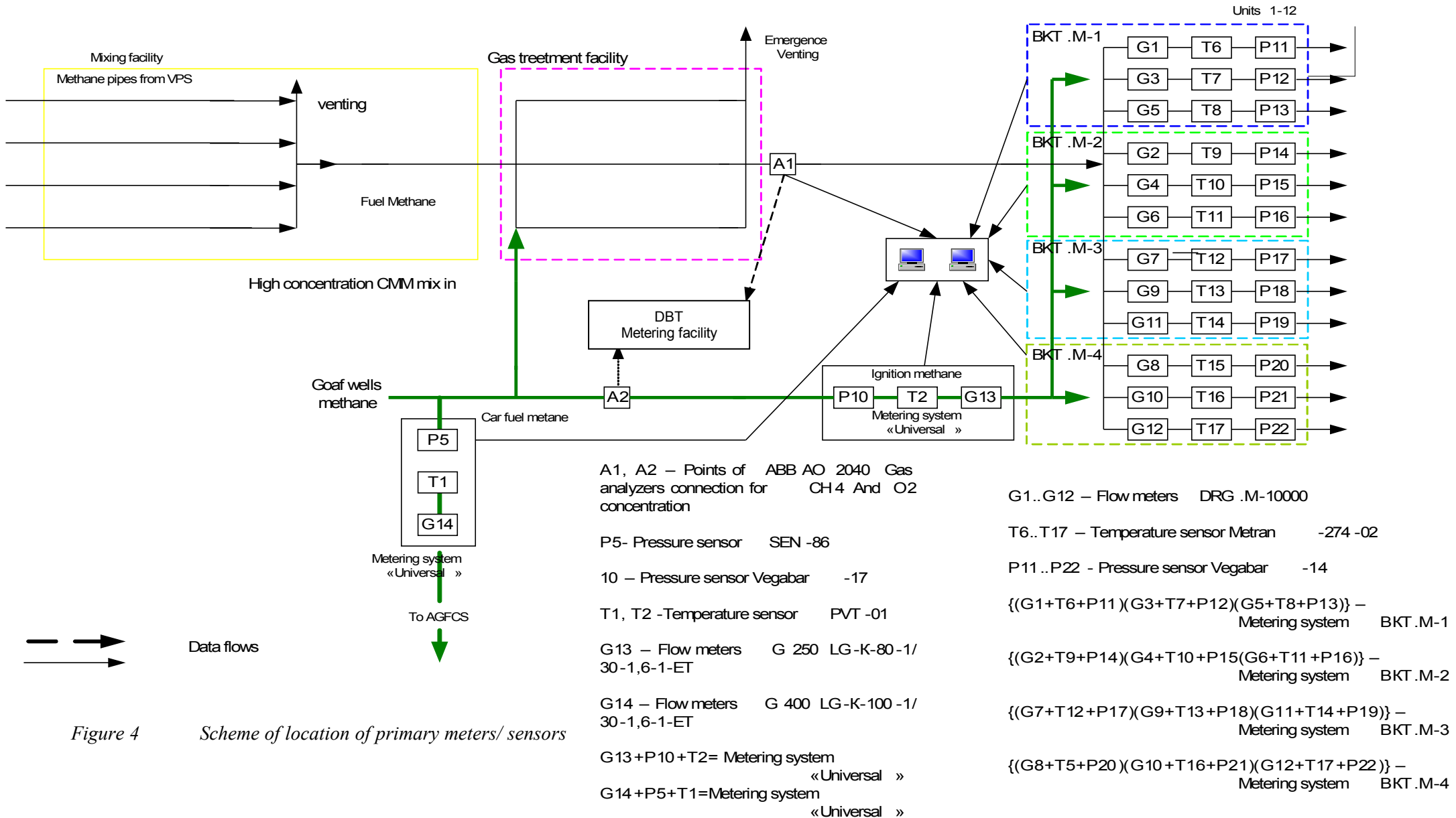

Figure 4 Scheme of location of primary meters/ sensors

JI MONITORING REPORT FORM

Monitoring Report #6 “Utilization of Coal Mine Methane at the Coal Mine named after A.F. Zasyadko” page 20

General scheme of location of meters /sensors at Vostochnaya CHP in 2009

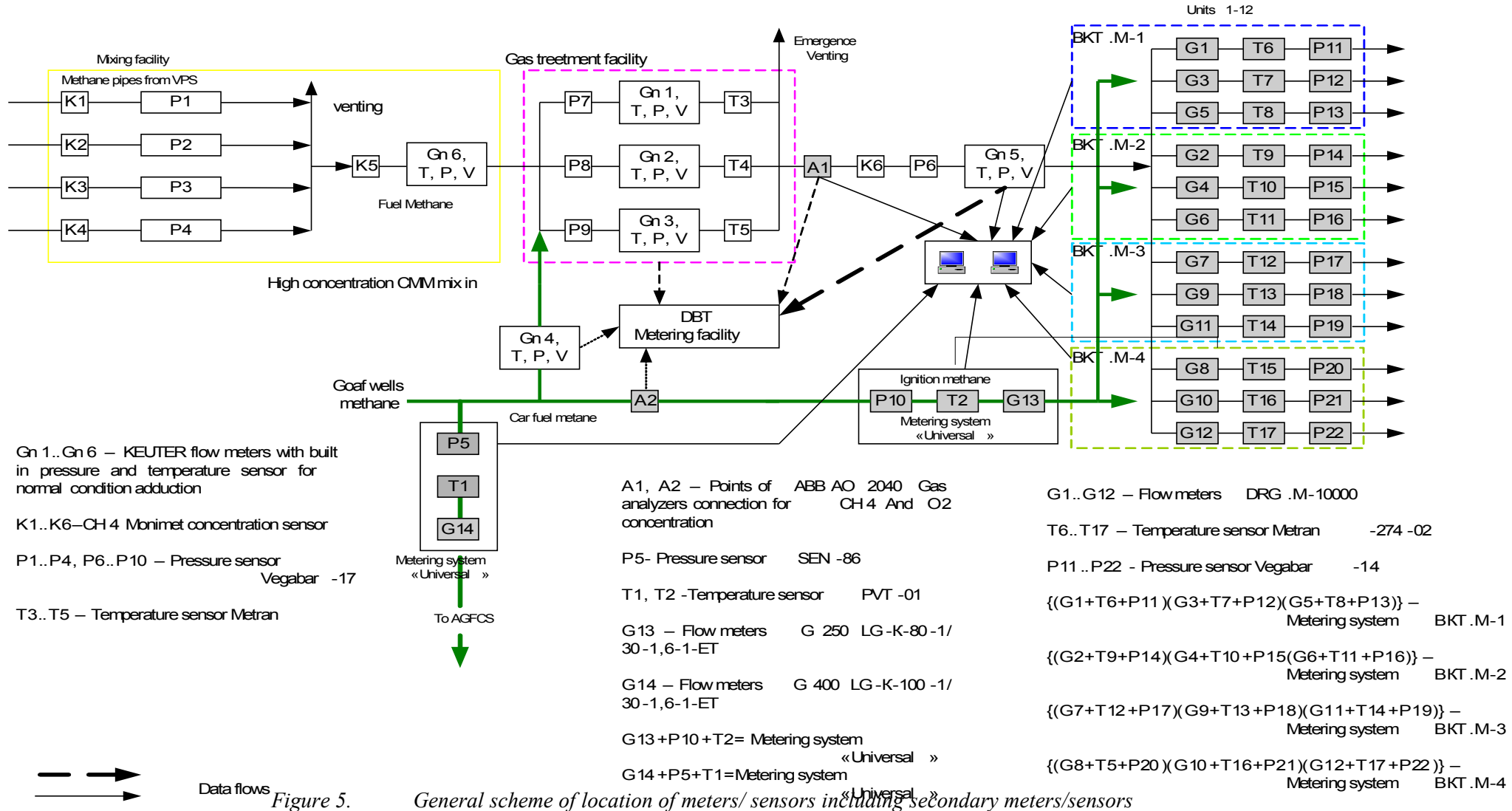

Figure 5. General scheme of location of meters/ sensors including secondary meters/sensors

JI MONITORING REPORT FORM

Monitoring Report #6 "Utilization of Coal Mine Methane at the Coal Mine named after A.F. Zasyadko" page 21

The general flow of CMM and the metering can be described as follows.¹⁰

Coal mine gas of degassing and gas-suction is supplied through four lines from two Vacuum Pump Station (VPS) to gas mixing section of the CHP gas treatment facility. The concentration and pressure of methane are different in each pipe-line. These parameters are measured by K1...K4 (Monimet) concentration sensors and P1...P4 (Vegabar) pressure sensors. Measurements data of these sensors are not used in gas metering and have technological meaning; these data are channelled to automatic control system of the dispatch and used only for controlling purposes in order to obtain at the output homogeneous fuel methane with necessary concentration.

Concentration of methane that is fed to the gas treatment facility is measured by the sensor K5 (Monimet); temperature, pressure and flow are measured by flow meters Gn6 (Keuter), a unit of velocity, pressure, and temperature sensors. Surface well methane is mixed with fuel gas, if increase of its concentration is required. Admix (flow), temperature, and pressure of surface well methane is measured by flow meter Gn4 (Keuter) a unit of velocity, pressure, and temperature sensors.. The concentration of admix methane from surface wells is measured by gas analyser AO 2040 (ABB) in A2 point (concentration of methane in admix and ignition gas are equal as these are included in common system of surface degasification- surface well gas methane). Having all this data the automatic control system of the dispatch can calculate amount of methane in the gas mixture.

At the gas treatment section of facility, methane is distributed between three lines where it is dried, cooled, cleaned and warmed. Acting flow measurements is provided by Gn1 - Gn3 (Keuter) flow meters together with velocity, pressure and temperature sensors. They transmit information to calculation equipment developed by DBT which is installed in separate premise. This unit calculates the values of actual consumption for normal conditions and channelled them to automatic control system of the dispatch computer system for operation and saving in database. For checking and reserve, pressure sensors P7 – P9 (Vegabar) and temperature sensors T3 – T5 (Metran) have been installed in pipe-lines.

At the outflow of gas treatment section the processing discharge valve is installed which levels out e pressure swings at abrupt changes of CHP operation regime. Pressure at the outflow of the section is controlled by processing sensor P6 (Vegabar).

With the purpose of fuel gas concentration definition, gas testing is made at the outflow of gas treatment section of facility in point A1 which is fed to gas analyzer AO 2040 (ABB) mounted at gas metering unit. Concentration measured is checked for the compliance with sensor K6 (Monimet). Flow meter Gn5 (Keuter) as a unit with velocity, pressure and temperature sensors, measures the gas amount used by CHP units. The methane amount is calculated based on the data of methane concentration but is not used for database establishment and metering, it is used only for technological purposes.

Further, fuel gas is supplied to the units of CHPs engine rooms. The flow meters G1- G12, type DPG.M-10000. temperature sensors T6 - T17 (Metran 274-02), and pressure sensors P11 - P22 (Vegabar -14) are mounted on the line of each 12 units. Their data are transmitted to micro- processing control system BKT.M designed for transformation of input information about gas parameters and for calculation of the base thereof of amount and volumetric amount of gas flow brought to standard conditions to calculate fuel gas amount which is used by each unit, and total amount in each engine room. Fuel gas amount is calculated based on the data of methane concentration in it. Fuel gas amount calculation is performed on the base of data received from control units for gas record BKT.M1-BKT.M4, and concentration of methane therein as received from gas analyzer AO 2040 (ABB) in point A1. Total amount of fuel gas is calculated by way of addition of figures of all gas record units BKT.M, and serves as a figure of CHP gas methane utilized. This information is entered into database and logs.

¹⁰ From 2008, DBT equipment is used as equipment for operation and control of stations, as well as for crosschecking. Main meters are installed at each CHP unit, and they transmit data to metering systems of the gas record units BKT.M. Gas record units BKT.M transmit data to computer. Each gas record units BKT.M covers 3 CHP units. These systems are operated with fuel gas. Ignition gas for all CHP units is metered with a new metering system Universal. All this data are stored in place, and are transmitted to CHP computer system.

Ignition gas is supplied to CHP units from gas pipes of surface degasification wells. Total ignition gas consumption is metered by system Universal designed for transformation of input information about gas parameters and for calculation of the base thereof of amount and volumetric amount of gas flow brought to standard conditions, which included gas metering device G13 (G 250 LG-K-80-1/30-1,6-1-Ex), temperature sensor T2 (PVT-01-1), and pressure sensor P10 (Vegabar-17). Gas concentration is metered by gas analyzer AO 2040 (ABB) with gas test in the point A2.

JI MONITORING REPORT FORM

Monitoring Report #6 “Utilization of Coal Mine Methane at the Coal Mine named after A.F. Zasyadko” page 22

Based on data received from metering system Universal, ignition gas automatic control system is kept, which gas is supplied to CHP units and recorded in database and log.

Gas that is supplied for motor vehicles filling, is also supplied from gas pipes of surface degasification wells. Total motor vehicle filling gas consumption G14 is metered by system Universal designed for transformation of input information about gas parameters and for calculation of the base thereof of amount and volumetric amount of gas flow brought to standard conditions, which included gas metering device G14 (G 400 LG-K-100-1/30-1,6-1-Ex), temperature sensor T2 (PVT-01-1), and pressure sensor P5 (CEN-8601). As the gas for vehicle fuelling and ignition gas fed to CHP units are of one system of surface degasification, gas concentration control is performed by gas analyzer AO 2040 (ABB) with gas test in the point A2. Based on data thereof, amount of methane fed to AGFCP for motor vehicle filling, is recorded in database and log.

Methane volume which is supplied with fuel gas and methane of ignition gas gives total amount of methane supplied to CHPs.

Methane volume which is supplied with fuel gas and methane of ignition gas, methane for automobiles filling give total amount of methane consumed by Vostochnaya site of Zasyad’ko coal mine.



Figure 6: flow gas meter DRG.M-10000¹¹, temperature sensor Metran 274-02 and pressure sensor Vegabar-14 of metering system for gas record BKT.M at fuel gas pipeline of CHP unit.

¹¹ DRG.M – 10000 — gas flow meter designed for transformation of volumetric flow of gas (at operational pressure) into numeric and impulsive signal.

JI MONITORING REPORT FORM

Monitoring Report #6 "Utilization of Coal Mine Methane at the Coal Mine named after A.F. Zasyadko" page 23

In the table below the description of the meters/sensors of metering systems for gas record that are part of monitoring report drawing, are given:

CHP gas metering equipment

Item No.	Metering instrument design	Work parameter	Manufacturer	Type	Serial number	Uncertainty level of data	Date of installation	Date of calibration	Date of next calibr.	Remarks
C1	Concentration of fuel gas	%	ABB	AO2040 Electronic	3.244705.5	±1%	2005	10.07.08 09.07.09	09.07.10	A1 connection
C2	Concentration of ignition gas	%	ABB	AO2040 Electronic	3.244704.5	±1%	2005	11.07.08 10.07.09	10.07.10	A2 connection

Calibration interval for gas analyzers is one year.

Ignition gas record system Universal meters/sensors

Item No.	Gas to be measured	Metering instrument design	Work parameter	Manufacturer	Type	Serial number	Uncertainty level of data	Date of installation	Date of calibration	Date of next calibr.	Remarks
V1	Ignition	Ignition gas amount measurement	m ³	NVP"GREMPIS" ltd	G 250 LGK-80-1/30-1,6-1-EX	9771	±2%	4 quarter 2007	23.03.07 10.03.09	10.03.11	G13 connection
		Ignition gas temperature measurement	°C	NVP"GREMPIS" ltd	PVT-01-1	6480	±0.5%	4 quarter 2007	23.07.08 10.03.09	10.03.11	T2 connection
		Ignition gas pressure measurement	bar	"VEGA" Germany	Vegabar-17	12307278	±0.5%	4 quarter 2007	23.07.08 10.03.09	10.03.10	P10 connection

Calibration interval for pressure sensor is one year.

Calibration interval for temperature sensor and gas meter is once in two years.

JI MONITORING REPORT FORM

Monitoring Report #6 "Utilization of Coal Mine Methane at the Coal Mine named after A.F. Zasyadko" page 24

Motor vehicle filling gas metering system Universal meters/ sensors

Item No.	Gas to be measured	Metering instrument design	Work parameter	Manufacturer	Type	Serial number	Uncertainty level of data	Date of installation	Date of calibration	Date of next calibr.	Remarks
V2	Gas for motor vehicle filling	Gas for motor vehicle filling amount measurement	M3	NVP"GREMPIS" ltd	G 400 LG-K-100-1/30-1,6-1-Ex	9786	±2%	4 quarter 2007	16.07.07 15.07.09	15.07.11	Connection G14
		Gas for motor vehicle filling temperature measurement	°C	NVP"GREMPIS" ltd	PVT-01-1	211	±0.5%	4 quarter 2007	28.07.08 28.07.09	28.07.11	Connection T1
		Gas for motor vehicle filling pressure measurement	bar	"COBOLD" Germany	SEN-86	45	±0.5%	4 quarter 2007	28.07.08 28.07.09	28.07.10	Connection P5

Calibration interval for pressure sensor is one year.

Calibration interval for temperature sensor and gas meter is once in two years.

Gas volume and volumetric consumption computing block

JI MONITORING REPORT FORM

Monitoring Report #6 “Utilization of Coal Mine Methane at the Coal Mine named after A.F. Zasyadko” page 25

JI MONITORING REPORT FORM

Monitoring Report #6 “Utilization of Coal Mine Methane at the Coal Mine named after A.F. Zasyadko” page 26

JI MONITORING REPORT FORM

Monitoring Report #6 "Utilization of Coal Mine Methane at the Coal Mine named after A.F. Zasyadko" page 27

Item No.	Metering system	Work parameter: m ³ /h	manufacturer	Type	Serial number	Uncertainty level of data and accuracy	Date of installation	Data as of 01.01.2009 m ³	Data as of 30.09.2009 m ³	Difference	Date of calibration	Date of next calibration	Remarks
V ₁	Universal	Ignition gas amount	NVP"GREMPIS" ltd	Universal -2	6023	±0.2 %	4 quarter 2007	2 038 654.1	3 228 583,3	1 189 929.2	23.07.08 10.03.09	10.03.11	Main metering block
V ₂	Universal	Motor vehicle fuelling gas amount	NVP"GREMPIS" ltd	Universal -2	327	±0.2 %	4 quarter 2007	3 529 833	4 959 363	1 429 530	28.07.08 15.07.09	15.07.11	Main metering block

Calibration interval-once in two years.

Gas volume and volumetric consumption computing blocks BKT.M -1 — BKT.M-4

Item No.	Metering system	Work parameter: m ³	Manufacturer	Serial number	Uncertainty level of data and accuracy	Date of installation	Unit No.	Data as of 01.01.2009 m ³	Data as of 30.09.2009 m ³	Difference	Date of calibration	Date of next calibration	Remarks		
V ₃	BKT.M-1	Fuel gas amount	Sibnefteavtomatika, Russia	245	• Pressure channels, not exceeding ±0.3 %;	N/A	M1	13 472 130	19 927 862	6 455 732	21.08.07	21.08.10	Main metering block		
							M3	13 226 072	18 488 410	5 262 338					
							M5	13 746 306	18 522 774	4 776 468					
V ₄	BKT.M-2	Fuel gas amount	Sibnefteavtomatika, Russia	Till 31.03.09 094		N/A	M2	In view of BKT.M substitution (on 31.03.09) see data on this recording block in the table below				13.11.07 05.05.09	05.05.12	Main metering block	
				After 31.03.09 095			M4					10.05.07 20.01.09	20.01.12		
							M6								
V ₅	BKT.M-3	Fuel gas amount	Sibnefteavtomatika, Russia	100		• Pressure channels, not exceeding ±0.3 %;	N/A	M7	7 638 879	10 806 784	3 167 905	18.03.08	18.03.11	Main metering block	
								M9	9 685 886	15 874 493	6 188 607				
								M11	8 808 041	15 079 168	6 271 127				
V ₆	BKT.M-4	Fuel gas amount	Sibnefteavtomatika, Russia Sibnefteavtomatika, Russia	099			• Pressure channels, not exceeding ±0.3 %;	N/A	M8	502 033,3	8 101 821	7 599 787,7	05.08.08	05.08.11	Main metering block
									M10	393 066,7	8 328 794	7 935 727,3			
									M12	0.0	142,2742	142,2742			

JI MONITORING REPORT FORM

Monitoring Report #6 “Utilization of Coal Mine Methane at the Coal Mine named after A.F. Zasyadko” page 29

--	--	--	--	--	--	--	--	--	--	--	--	--	--	--	--

•, not exceeding ±0.1 %.

Gas volume and volumetric consumption computing blocks BKT.M-2 (before and after substitution on 31.03.09)

Item No.	Metering system	Serial number	Unit No.	Data as of 01.01.2009, m ³	Change of running m ³ Data as of 31.03.2009	Difference	Serial number	Unit No.	m ³ Data as of 31.03.2009	m ³ Data as of 30.09.2009	Difference	Σ gas consumption
V ₄	BKT.M-2	094	M2	14 554 379	18 691 097	4 136 718	095	M2	0.0	7 562 053	7 562 053	11 698 771
			M4	2 923 449	2 923 449	0.0		M4	0.0	6 644 658	6 644 658	6 644 658
			M6	11 930 812	15 635 790	3 704 978		M6	0.0	6 833 283	6 833 283	10 538 261

JI MONITORING REPORT FORM

Monitoring Report #6 “Utilization of Coal Mine Methane at the Coal Mine named after A.F. Zasyadko” page 30

Meters/ sensors of fuel gas metering system BKT.M – 1

JI MONITORING REPORT FORM

Monitoring Report #6 “Utilization of Coal Mine Methane at the Coal Mine named after A.F. Zasyadko” page 31

Item No.	Gas to be metered	Symbol on scheme	Metering device designation	Work parameter	Manufacturer	Type	Serial number	Allowed uncertainty	Date of installation	Date of calibration	Date of next calibration	Remarks
M1	Fuel	G1	Fuel gas amount measurement	m3	Sibnefteavtomatika, Russia	DRG.M-10000. Electronic	102	±1.0%	N/A	16.07.08 19.08.09	19.08.11	Fuel gas metering system BKT.M- 1
		T6	Fuel gas temperature measurement	°C	Metran Industrial Group, Russia	Metran -274-02	510745	±0,5%	N/A	22.07.08 22.07.09	22.07.10	
		P11	Fuel gas pressure measurement	bar	"VEGA" Germany	Vegabar 14	14536534	±0,5%	N/A	04.06.08 04.06.09	04.06.10	
M3	Fuel	G3	Fuel gas amount measurement	m3	Sibnefteavtomatika, Russia	DRG.M-10000. Electronic	109	±1.0%	N/A	18.07.08 19.08.09	19.08.11	
		T7	Fuel gas temperature measurement	°C	Metran Industrial Group, Russia	Metran -274-02	510753	±0,5%	N/A	04.07.08 03.07.09	03.07.10	
		P12	Fuel gas pressure measurement	bar	"VEGA" Germany	Vegabar 14	14536342	±0,5%	N/A	04.06.08 04.06.09	04.06.10	
M5	Fuel	G5	Fuel gas amount measurement	m3	Sibnefteavtomatika, Russia	DRG.M-10000. Electronic	103	±1.0%	N/A	17.07.08 19.08.09	19.08.11	
		T8	Fuel gas temperature measurement	°C	Metran Industrial Group, Russia	Metran -274-02	509669	±0,5%	N/A	22.07.08 22.07.09	22.07.10	
		P13	Fuel gas pressure measurement	bar	"VEGA" Germany	Vegabar 14	14447569	±0,5%	N/A	04.06.08 04.06.09	04.06.10	

Calibration interval of pressure and temperature sensor is one year.

Calibration interval of gas consumption sensors is once in two years.

(by calibration of DRG.M - 10000 at Ivano-Frankovskstandartmetrologia State-Owned Enterprise, calibration interval has been changed from 3 to 2 years)..

Meters/ sensors of fuel gas metering system BKT.M – 2

JI MONITORING REPORT FORM

Monitoring Report #6 “Utilization of Coal Mine Methane at the Coal Mine named after A.F. Zasyadko” page 32

Item No.	Gas to be metered	Symbol on scheme	Metering device designation	Work parameter	Manufacturer	Type	Serial number	Allowed uncertainty	Date of installation	Date of calibration	Date of next calibration	Remarks
M2	Fuel	G2	Fuel gas amount measurement	m ³	Sibnefteavtomatika, Russia	DRG.M-10000. Electronic	108	± 1.0%	N/A	15.07.08 15.06.09	15.06.11	Fuel gas metering system BKT.M - 2
		T9	Fuel gas temperature measurement	°C	Metran Industrial Group, Russia	Metran -274-02	510735	± 0.5%	N/A	21.07.08 21.07.09	21.07.10	
		P14	Fuel gas pressure measurement	bar	"VEGA" Germany	Vegabar 14	14568471	± 0.5%	N/A	02.06.08 02.06.09	02.06.10	
M4	Fuel	G4	Fuel gas amount measurement	m ³	Sibnefteavtomatika, Russia	DRG.M-10000. Electronic	104	± 1.0%	N/A	15.07.08 15.06.09	15.06.11	
		T10	Fuel gas temperature measurement	°C	Metran Industrial Group, Russia	Metran -274-02	509670	± 0.5%	N/A	21.07.08 21.07.09	21.07.10	
		P15	Fuel gas pressure measurement	bar	"VEGA" Germany	Vegabar 14	14536186	± 0.5%	N/A	02.06.08 02.06.09	02.06.10	
M6	Fuel	G6	Fuel gas amount measurement	m ³	Sibnefteavtomatika, Russia	DRG.M-10000. Electronic	097	± 1.0%	N/A	16.07.08 15.06.09	15.06.11	
		T11	Fuel gas temperature measurement	°C	Metran Industrial Group, Russia	Metran -274-02	510733	± 0.5%	N/A	21.07.08 21.07.09	21.07.10	
		P16	Fuel gas pressure measurement	bar	"VEGA" Germany	Vegabar 14	14536368	± 0.5%	N/A	02.06.08 02.06.09	02.06.10	

Calibration interval of pressure and temperature sensor is one year.
Calibration interval of gas consumption sensors is once in two years.

Meters/ sensors of fuel gas metering system BKT.M – 3

JI MONITORING REPORT FORM

Monitoring Report #6 “Utilization of Coal Mine Methane at the Coal Mine named after A.F. Zasyadko” page 33

Item No.	Gas to be metered	Symbol on scheme	Metering device designation	Work parameter	Manufacturer	Type	Serial number	Allowed uncertainty	Date of installation	Date of calibration	Date of next calibration	Remarks
M7	Fuel	G7	Fuel gas amount measurement	m ³	Sibnefteavtomatika, Russia	DRG.M-10000. Electronic	098	± 1.0%	N/A	16.07.08 17.07.09	17.07.11	Fuel gas metering system BKT.M - 3
		T12	Fuel gas temperature measurement	°C	Metran Industrial Group, Russia	Metran -274-02	510744	± 0,5%	N/A	21.07.08 21.07.09	21.07.10	
		P17	Fuel gas pressure measurement	bar	"VEGA" Germany	Vegabar 14	14568573	± 0,5%	N/A	03.06.08 03.06.09	03.06.10	
M9	Fuel	G9	Fuel gas amount measurement	m ³	Sibnefteavtomatika, Russia	DRG.M-10000. Electronic	099	± 1.0%	N/A	17.07.08 17.07.09	17.07.11	
		T13	Fuel gas temperature measurement	°C	Metran Industrial Group, Russia	Metran -274-02	510742	± 0,5%	N/A	21.07.08 21.07.09	21.07.10	
		P18	Fuel gas pressure measurement	bar	"VEGA" Germany	Vegabar 14	14536304	± 0,5%	N/A	03.06.08 03.06.09	03.06.10	
M11	Fuel	G11	Fuel gas amount measurement	m ³	Sibnefteavtomatika, Russia	DRG.M-10000. Electronic	101	± 1.0%	N/A	17.07.08 17.07.09	17.07.11	
		T14	Fuel gas temperature measurement	°C	Metran Industrial Group, Russia	Metran -274-02	510738	± 0,5%	N/A	21.07.08 21.07.09	21.07.10	
		P19	Fuel gas pressure measurement	bar	"VEGA" Germany	Vegabar 14	14568610	± 0,5%	N/A	03.06.08 03.06.09	03.06.10	

Calibration interval of pressure and temperature sensor is one year.
 Calibration interval of gas consumption sensors is once in two years.
 Meters/ sensors of fuel gas metering system BKT.M – 4

JI MONITORING REPORT FORM

Monitoring Report #6 “Utilization of Coal Mine Methane at the Coal Mine named after A.F. Zasyadko” page 34

Item No.	Gas to be metered	Symbol on scheme	Metering device designation	Work parameter	Manufacturer	Type	Serial number	Allowed uncertainty	Date of installation	Date of calibration	Date of next calibration	Remarks
M8	Fuel	G8	Fuel gas amount measurement	m ³	Sibnefteavtomatika, Russia	DRG.M-10000. Electronic	105	± 1.0%	N/A	17.07.08 01.07.09	01.07.11	Fuel gas metering system BKT.M - 4
		T15	Fuel gas temperature measurement	°C	Metran Industrial Group, Russia	Metran -274-02	510754	± 0,5%	N/A	24.07.08 24.07.09	24.07.10	
		P120	Fuel gas pressure measurement	bar	"VEGA" Germany	Vegabar 14	14568589	± 0,5%	N/A	05.06.08 05.06.09	05.06.10	
M10	Fuel	G10	Fuel gas amount measurement	m ³	Sibnefteavtomatika, Russia	DRG.M-10000. Electronic	096	± 1.0%	N/A	18.07.08 01.07.09	01.07.11	
		T16	Fuel gas temperature measurement	°C	Metran Industrial Group, Russia	Metran -274-02	510755	± 0,5%	N/A	24.07.08 24.07.09	24.07.10	
		P21	Fuel gas pressure measurement	bar	"VEGA" Germany	Vegabar 14	14536306	± 0,5%	N/A	05.06.08 05.06.09	05.06.10	
M12	Fuel	G12	Fuel gas amount measurement	m ³	Sibnefteavtomatika, Russia	DRG.M-10000. Electronic	100	± 1.0%	N/A	15.07.08 01.07.09	01.07.11	
		T17	Fuel gas temperature measurement	°C	Metran Industrial Group, Russia	Metran -274-02	510747	± 0,5%	N/A	24.07.08 24.07.09	24.07.10	
		P22	Fuel gas pressure measurement	bar	"VEGA" Germany	Vegabar 14	14568606	± 0,5%	N/A	05.06.08 05.06.09	05.06.10	

Calibration interval of pressure and temperature sensor is one year.
Calibration interval of gas consumption sensors is once in two years.

JI MONITORING REPORT FORM

Monitoring Report #6 “Utilization of Coal Mine Methane at the Coal Mine named after A.F. Zasyadko” page 31

The monitoring system for the emission reductions achieved in the course of the project implementation has been integrated in the Zasyadko Coal Mine existing controlling and reporting system. That allows for obtaining reliable and easy verifiable data related to the project performance, ensuring thus the quality and efficiency of the monitoring system.

All source information on performance parameters and calculations have been obtained directly on site and after that reported to the Coal Mine dispatching office. The work parameters of CMM flows as well as heat and power generated will be crosschecked to provide quality and reliability of monitored data. To ensure reliable and non-stop performance of cogeneration plant the inputs of natural gas from the natural gas pipeline are envisaged.

CMM consumption of gas filling stations

Each gas filling station keeps records in the register. Calculations of methane fuelled are executed according to data pressure difference of manometers. Concentration of methane is measured monthly with ABB AO 2040 at CHP and surface well gas analysis. Besides, the concentration of methane is measured locally with an interferometer. Temperature and pressure meters are installed too. The volume of methane is measured by “Universal-2” metering system.

B.1.3. Calibration procedures

For Electricity Meters:

QA/QC (Quality Assurance/ Quality Control) procedures	Body responsible for calibration and certification
Calibration interval of such meters is six years. Calibration procedures for meters are implemented in compliance with calibration methodology developed for “Elster-Metronika” meters, Russia. Manufacturer's warranty-36 months	Manufacturer “Elster-Metronika” LLC, Russia

For Heat Meters

QA/QC (Quality Assurance/ Quality Control) procedures	Body responsible for calibration and certification
Calibration interval of such meters is two years. Calibration procedures for meters are implemented in compliance with calibration methodology developed for ASWEGA meters, Russia. Manufacturer's warranty-18 months	Donetsk Centre for Standardization and Metrology

For CMM meters:

QA/QC (Quality Assurance/ Quality Control) procedures	Body responsible for calibration and certification
Keuter ADM1 Electronic. Calibration interval of such meters is 1 year ¹² .	Donetsk Centre for Standardization and Metrology
Gas Analyzer ABB A02040. Calibration interval of such meters is 1 year ¹² .	Donetsk Centre for Standardization and Metrology

B.1.4. Involvement of Third Parties:

- Donetsk Centre for Standardization and Metrology¹³.
- Ivano-Frankovsk for Standardization and Metrology

B.2. Data collection (accumulated data for the whole monitoring period):

For the operational and management structure of the project see PDD, Figure 5 : *Monitoring and quality control system for Vostochnaya and Yakovlevskaya sites*

¹² As there is no state regulation for such kind of equipment there was a decision of Ukrainian Centre for Standardization and Metrology for one year calibration period.

¹³ All metering equipment shall be calibrated subject to provisions and methods as defined by regulations of this centre.

JI MONITORING REPORT FORM

Monitoring Report #6 “Utilization of Coal Mine Methane at the Coal Mine named after A.F. Zasyadko” page 32

B.2.1. List of fixed default values:

ID number	Data variable	Source of data	Data unit	Comment
P6 CEF _{CH4}	Carbon emission factor for combusted methane	2006 IPCC Guidelines for National Greenhouse Gas Inventories. Volume 2: Energy Chapter 4: Fugitive Emissions	tCO ₂ e/tCH ₄	Set at 2.75 tCO ₂ e /tCH ₄ See also table CMM meters
P12 Eff _{CHP}	Efficiency of methane destruction/oxidation in CHP	2006 IPCC Guidelines for National Greenhouse Gas Inventories. Volume 2: Energy Chapter 4: Fugitive Emissions	%	Set at 99.5%
P14 Eff _{GAS}	Overall efficiency of methane destruction/oxidation at the vehicles	2006 IPCC Guidelines for National Greenhouse Gas Inventories. Volume 2: Energy Chapter 4: Fugitive Emissions	%	Set at 98.5%
P15 GWP _{CH4}	Global warming potential of methane	2006 IPCC Guidelines for National Greenhouse Gas Inventories. Volume 2: Energy Chapter 4: Fugitive Emissions	tCO ₂ e/tCH ₄	Set at 21

Table 4: Project variables

ID number	Data variable	Source of data	Data unit	Comment
B13 EF _{grid,generated,y}	Emissions factor of electricity of replaced grid electricity production by the project activity in year	See annex 2	tCO ₂ /MWh	See annex 2 PDD See also table “Electrical Meters”
B14 EF _{grid,reduced,y}	Emissions factor of electricity of replaced on-site electricity consumption by the project activity	See annex 2	tCO ₂ /MWh	See annex 2 PDD See also table “Electrical Meters”
B20 EF _{heat,vost}	Emissions factor for heat at Vostochnaya site in the baseline scenario	Boiler efficiency	tCO ₂ /GJ	See annex 2 PDD See also table “Heat Meters”
B22 EF _{heat,yak}	Emissions factor for heat at Yakovlevskaya site in the baseline scenario	Boiler efficiency	tCO ₂ /GJ	See annex 2 PDD See also table “Heat Meters”
B24 EF _{heat,centr}	Emissions factor for heat at Centralnaya site in the baseline scenario	Boiler efficiency	tCO ₂ /GJ	See annex 2 PDD. See also table “Heat Meters”
B25 VFUEL _y	Vehicle fuel provided by the project activity	Fuel Meters	GJ	This value will be calculated based MM _{GAS} of the project scenario multiplied with LHV of methane
B26 EF _v	Emissions factor for vehicle operation replaced by the project activity	2006 IPCC Guidelines for National Greenhouse Gas Inventories. Volume 2: Energy Chapter 4: Fugitive Emissions	tCO ₂ /GJ	See annex 2 PDD

Table 5: Baseline Variables

B.2.2. List of variables:

Project emissions variables to be measured:

JI MONITORING REPORT FORM

Monitoring Report #6 "Utilization of Coal Mine Methane at the Coal Mine named after A.F. Zasyadko" page 33

- MM_{CHP} - Methane measured sent to power plant (tCH4)
- MM_{GAS} - Methane measured supplied to gas grid for vehicle use (tCH4)

Baseline emissions variables to be measured:

- GEN_{CHP} - Net electricity generated by the project activity by the CHP plants
- $El_{Consumed}$ Net electricity consumed by the mine on-site
- $HEAT_{cons, vost, y}$ Heat consumed at Vostochnaya site delivered by the project year y

B2.3. Data concerning GHG emissions by sources of the project activity (referring to paragraph 53(a)):

Year	MM_{GAS} (tCH4)
9 months 2009	953

Table 6: Data to be collected in the project scenario

Year	MM_{CHP} (tCH4)
9 months 2009	20 407

Table 7: Data to be collected in the project scenario

For Methane analysis data refer please to Annex 1 document.

B.2.4. Data concerning GHG emissions by sources of the baseline (referring to paragraph 53(b)):

Year	GEN_{CHP} (MWh)	El_{Cons} (MWh)	$HEAT_{cons, vost, y}$ (GJ)
9 months 2009	95 656.844	137 865.158	106 441.016

Table 8: Data collected in the baseline scenario

Methane analysis data- see Annex 1.

B.2.5. Data concerning leakage (referring to paragraph 53(c)):

Not Applicable.

B.2.6. Data concerning environmental impacts (referring to paragraph 53(d)):

Not Applicable.

B.3. Data processing and archiving (incl. software used):

All data will be archived electronic and paper. (See CO₂ calculation)

B.4. Special event log:

During this monitoring period, no special events occurred.

SECTION C. Quality assurance and quality control measures:

C.1. Documented procedures and management plan:

C.1.1. Roles and responsibilities:

The general project management is implemented by the Deputy General Director of the Zasyadko Coal Mine through supervising and coordinating activities of his subordinates, such as deputy director on surface degasification, chief power engineer, chief heating engineer, and heads of safety engineering departments. On-site day-to-day management is implemented by the manager of cogeneration station who directs two shift operators responsible for cogeneration modules and gas treatment plant performance. An on-duty electrician works at the plant. During the daytime a group of mechanics who are responsible for preventive measures and maintenance of all technological equipment, metering instruments as well as of automation tools and telemechanics are present on-site. On-line information transmitted directly to the head of the shift into the Coal Mine Central Dispatching Office. The cogeneration plant is in 24 hours operation. Three shifts by eight hours have been introduced.

At the main objects the responsibilities are as follows:

- VPS operator controls data before VPS and after VPS (at the gas treatment plant) including CMM and natural gas flow parameters;
- Two cogeneration plant operators control data at the inlets of cogeneration modules (at the gas treatment plant), work process parameters, and heat and power output. Substation operator controls data on electric power amounts dispatched to and supplied from the grid as well as in-house electricity consumption.

All the information will be channelled to the workstation of the Coal Mine central dispatching office and on-line monitored by the head of the shift that will be responsible for calculation of the CO₂ equivalent emission reductions. Such calculations are made on a monthly basis. The general supervision of the monitoring system is executed by Zasyadko Coal Mine administration under the existing control and reporting system.

C.1.2. Trainings:

C.2. Involvement of Third Parties:

The Donetsk Centre for Standardization and Metrology and Ivano-Frankovsk Centre for Standardization and Metrology are Third Parties involved.

C.3. Internal audits and control measures:

Introduction of a modern computerized control system allows for efficient on-line monitoring and reviewing work process performance at the Zasyadko Central Dispatching office every fifteen minutes. (Especially for fuel and ignition gas consumption, their parameters and electricity and heat generated data can be obtained every 10 seconds if requested). Any considerable deviation of monitored data from given work parameters will be promptly noticed and source of such deviation will be easily identified. In turn this enables the head of shift to efficiently coordinate adjustment actions of his shift subordinates including on-duty technical staff that will improve work process and eliminate such deviations. This system improved operational process and eliminated lacks in control of CHP gas consumption.

C.4. Troubleshooting procedures¹⁴:

See C .1.2

In case of a break down of CMM supply system (either of whole system or separate feeding pipe) methane-air mixture will be urgently released into the atmosphere through the emergency gas vent stack. The shut-off valves will automatically close CMM supply pipes, natural gas will be fed into gas treatment plant and consequently into the inlets of engines and into pre-chambers. As the main gas record blocks (Figure 4) are after the venting stack, only combusted CMM will be accounted for.

¹⁴ At CHP, the equipment of the same type is installed, for substitution of main equipment for short period in case of breakdown or calibration- electricity and heat meters, CMM metering equipment, pressure, temperature sensors, etc. These devices, being connected to or installed, are able to transfer all data to monitoring and control computer system. Equipment is also calibrated in certain period by Centre for Standardization and Metrology, and Ivano-Frankovsk Centre for Standardization and Metrology.

SECTION D. Calculation of GHG emission reductions

D.1. Project emissions

The project emissions of the project are given by the following equation. The emissions for the use to capture and use methane PE_{ME} have not been taken as the energy use for the vacuum pumps are outside the project boundary (see section B.3 of PDD) and the annual electricity consumption of the gas filling station results in emission below 2,000 tCO₂e.

$$PE_y = PE_{MD} + PE_{UM}, \quad (5.)$$

where :

-Project emission in year y (tCO₂e);

PE_y -

Project emissions from methane destroyed (tCO₂e);

PE_{MD} -

PE_{UM} - Project emissions from un-combusted methane (tCO₂e)

The project emissions from methane destroyed

The project emissions from methane destroyed are given by the equation below. Methane will be destroyed in CHPs and as the CHP produces both electricity and heat at one source, MD_{ELEC} and MD_{HEAT} are combined into MD_{CHP} . No flaring takes place so $MD_{FL} = 0$.

$$PE_{MD} = (MD_{CHP} + MD_{GAS}) \times (CEF_{CH_4} + r \times CEF_{NMHC}), \quad (6.)$$

at $r = PC_{NMHC} / PC_{CH_4}$

where

Project emissions from CMM destroyed (tCO₂e);

PE_{MD} -

Methane destroyed in the CHPs (tCH₄);

MD_{CHP} -

MD_{GAS} -

Methane destroyed by the vehicles supplied by the new gas filling stations (tCH₄);

CEF_{CH_4} -

Carbon emission factor for combusted methane (2.75 tCO₂e/tCH₄).

¹⁵ CEF_{NMHC} - Carbon emission factor for combusted non-methane hydrocarbons (the concentration varies, and, therefore, to be obtained through periodical analysis of captured methane) (tCO₂eq/tNMHC)

r – relative proportion of NMHC compared with methane;

PC_{CH_4} - concentration (in mass) of methane in extracted gas (%);

PC_{NMHC} - concentration (in mass) of NMHC in extracted gas (%);

The relative proportion of NMHC was monitored, and their concentration is less than 1%. Therefore, NMHC were excluded from calculation. So:

$$PE_{MD} = (MD_{CHP} + MD_{GAS}) \times CEF_{CH_4}, \quad (7.)$$

Emissions of CHPs

The emissions of CHPs are given by following equations:

$$MD_{CHP} = MM_{CHP} \times Eff_{CHP}, \quad (8.)$$

where :

MD_{CHP} - Methane destroyed at heat and power generation (tCH₄);

MM_{CHP} - Measured methane sent to CHP (tCH₄);

Eff_{CHP} - Efficiency of methane destruction/ oxidation at CHP (taken as 99.5% or IPCC);

¹⁵ At the moment non methane hydrocarbons are not included in calculation because of concentration less than 1%. Their concentration is checked quarterly with laboratory analyses. In case of concentration more than 1% it will be considered in calculations.

JI MONITORING REPORT FORM

Monitoring Report #6 "Utilization of Coal Mine Methane at the Coal Mine named after A.F. Zasyadko" page 36

D.2. Emissions of gas utilization

Some methane will be supplied to the gas filling stations that will supply the vehicles. The emissions as a result are given by the following equations.

$$MD_{GAS} = MM_{GAS} \times Eff_{GAS}, \quad (9.)$$

where :

- MD_{GAS} - Methane destroyed by the vehicles supplied by the gas filling stations (tCH4)
- MM_{GAS} - Methane measured supplied to vehicles supplied by the gas filling stations (tCH4)
- Eff_{GAS} - Overall efficiency of methane destruction/ oxidation through gas grid to various combustion end uses, combining fugitive emissions from the gas grid and combustion efficiency at end user (taken as 98.5% or IPCC)

Emissions from un-combusted methane.

$$PE_{UM} = GWP_{CH4} \times (MM_{CHP} \times (1 - Eff_{CHP}) + MM_{GAS} \times (1 - Eff_{GAS})), \quad (10.)$$

where :

- PE_{UM} - Project emissions from un-combusted methane (tCO2e);
- GWP_{CH4} - Global warming potential of methane (21 tCO2e/tCH4);
- MM_{CHP} - Methane measured sent to use at CHP (tCH4);
- Eff_{CHP} - Efficiency of methane destruction in CHP (taken as 99.5% or IPCC);
- MM_{GAS} - Methane measured sent to use for gas filling (tCH4);
- Eff_{GAS} - Efficiency of methane destruction in vehicle usage (taken as 98.5% or IPCC);

D.3.1. Project emissions:

Project emissions
Total 1st half 2009

D.3.2. Baseline emissions:

The baseline emissions are given by following equation. There is no destruction of methane in baseline scenario at the mine, so $BEMD_{y} = 0$.

$$BE_{y} = BE_{MR,y} + BE_{Use,y}, \quad (11.)$$

where :

- BE_{y} - Baseline emissions in year y (tCO2e);
- $BE_{MR,y}$ - Baseline emissions from release of methane into the atmosphere that are avoided by the project activity in year y (tCO2e);
- $BE_{Use,y}$ - Baseline emissions from the production of power, heat replaced by the project activity in year y (tCO2e).

Baseline emissions of methane avoided by the project activity.

As there is neither CBM (coal bed methane) nor CMM (coal mine methane) at the mine, the emissions equal the amount of post-mining CMM captured in the project activity that is sent to CHP and the gas filling stations.

$$BE_{MR,y} = GWP_{CH4} \times (CMM_{PJ,CHP,y} + CMM_{PJ,GAS,y}), \quad (12.)$$

where :

- $CMM_{PJ,CHP,y}$ - Post-mining CMM captured, sent to and destroyed in the CHP in the project activity in year y (tCH4);
- $CMM_{PJ,GAS,y}$ - Pre-mining CMM captured, supplied to the net gas filling stations and destroyed by the vehicles in the project activity in year y (tCH4);
- GWP_{CH4} - Global warming potential for methane (=21 tCO2e/tCH4).

Baseline emissions of replacement of electricity, heat and vehicle fuel by the project activity

JI MONITORING REPORT FORM

Monitoring Report #6 "Utilization of Coal Mine Methane at the Coal Mine named after A.F. Zasyadko" page 37

As there is only post-mining CMM involved the baseline emissions are given in the following equation:

$$B_{Use,y} = B E_{Use_{el},y} + B E_{Use_{heat},y} + B E_{Use_{gas},y}, \quad (13.)$$

where :

$B_{Use,y}$ - Potential total baseline emissions from the production of power, heat, and vehicle fuels

replaced by the project activity in year y (tC O₂);

$B E_{Use_{el},y}$ - Total baseline emissions from the production of power, replaced by the project activity in year y (tC O₂);

$B E_{Use_{heat},y}$ - Total baseline emissions from the production of heat, replaced by the project activity in year y (tC O₂);

$B E_{Use_{gas}}$ - Total baseline emissions of vehicle fuels, replaced by the project activity in year y (tCO₂e);

Baseline emissions of replacement of electricity (power)

Baseline emissions of replacement of electricity by the project activity are given by two equations. When the amount of electricity generated in a year by the project activity is less than the total amount of electricity consumed by mine, the baseline emissions are as follows:

$$B E_{Use_{el},y} = GEN_{CHP,y} \times EF_{grid, reduced,y}, \quad (14.)$$

When the amount of electricity generated in year by the project activity is more than total amount of electricity consumed by mine (i.e. electricity will be supplied to the grid), the baseline emissions are as follows:

$$B E_{Use_{el},y} = (GEN_{CHP,y} - EL_{cons,y}) \times EF_{grid, produced,y} + EL_{cons,y} \times EF_{grid, reduced,y}, \quad (15.)$$

where :

$B E_{Use_{el},y}$ - Total baseline emissions from the production of power, replaced by the project activity in year y (tCO₂);

$GEN_{CHP,y}$ - Net electricity generated by the project activity of the CHP plants (MWh);

$EF_{grid, produced,y}$ - Emission factor of electricity of replaced grid electricity production by the project activity in year y (tCO₂/ MWh)

$EL_{cons,y}$ - Net electricity consumed by mine on-site in year y (MWh);

$EF_{grid, reduced,y}$ - Emissions factor for electricity of replaced on-site electricity consumption by the project activity (tCO₂/MWh)

Please note that for this monitoring period the net electricity generated is less than net electricity consumed (see section B.1.2). As a consequence formula 14 was used, and formula 15 was discarded. However, in August 2009, net amount of electricity generated by CHP exceeded net amount of electricity consumed by mine; as a result, formula 15 has been used.

Baseline emissions of replacement of heat

Heat produced by CHP supplies Vostochnaya site. Baseline emissions are given by following equation.

$$B E_{Use_{Heat},y} = HEAT_{cons,vost,y} \times EF_{Heat,vost} \quad (16.)$$

where :

$HEAT_{cons,vost,y}$ - Heat consumed at Vostochnaya site, supplied by the project activity in year y (GJ);

$EF_{Heat,vost}$ - Emission factor for heat at Vostochnaya site in the baseline scenario (tCO₂/GJ).

JI MONITORING REPORT FORM

Monitoring Report #6 “Utilization of Coal Mine Methane at the Coal Mine named after A.F. Zasyadko” page 38

Baseline emissions of replacement of vehicle fuels

The baseline emissions of the replacement of vehicle fuels by the project activity are given by the following equation.

$$BE_{Use.Gas} = VFUEL_y \times EF_v \quad (17.)$$

where :

$VFUEL_y$ - Vehicle (GJ);

EF_v - Emission factor for vehicle operation replaced by the project activity (tCO₂/GJ).

Emission factor for vehicle fuels

Emission factor for vehicle fuels is given by following equation.

$$EF_v = \frac{EF_{cos\lambda}}{Eff_v} \times \frac{44}{12} \times \frac{1TJ}{1000GJ} \quad (18.)$$

where :

EF_v - Emission factor for vehicle fuels replaced by the project activity (tCO₂/GJ).

$EF_{cos\lambda}$ - Emission factors for CO₂ for fuels used for vehicle operation replaced by the project activity (tCO₂/GJ).

Eff_v - Efficiency of vehicle motors (%);

44/12 – Carbon to Carbon Dioxide conversion factor;

1/1000 – TJ to GJ conversion factor.

D.3.1. Project emissions:

Year	[tCO ₂ e/year]	
Total: 9 months 2009	[tCO ₂ e]	60 862

Table 9: project emissions

D.3.3. Leakages:

Not Applicable

D.3.4. Emission reduction summary in monitoring period:

Year	[tCO ₂ e/year]	
Total: 1 st half 2009	[tCO ₂ e]	544 394

Table 10: Baseline emissions

Year	[tCO ₂ e/year]	
Total: 9 months 2009	[tCO ₂ e]	483 532

Table 11: Emission reductions

JI MONITORING REPORT FORM

Monitoring Report #6 "Utilization of Coal Mine Methane at the Coal Mine named after A.F. Zasyadko" page 39

ANNEX 1

Gas sample analysis – 1st quarter 2009

APPROVED
P.S.Pashkovskiy
First Director Deputy, Science
Activity, Dr. Sc. < signature >
Seal
The 17th of February, 2009

Percentage of matters in samples of gas taken on 06.02.09
at Lease Enterprise Mine named after A.F.Zasyadko

Main components	Sampling point	
	Vacuum Pump Station-4	
	First Group	Second Group
	Concentration, %	Concentration, %
Methane CH ₄	14,3	35,9
Ethan C ₂ H ₆	0,08	0,3
Propane C ₃ H ₈	0,002	0,07
Butane C ₄ H ₁₀	0,002	0,001
Pentane C ₅ H ₁₂	N/A	N/A
Hexane C ₆ H ₁₄	N/A	N/A
Carbon Oxide CO	0,0005	0,0009
Hydrogen H ₂	N/A	0,05
Carbon Dioxide CO ₂	0,06	0,05
Nitrogen N ₂	68,2	51,5
Oxygen O ₂	14,2	11,7
Argon Ar	0,83	0,58
Micro-Components	mg/Nm³	
Ammonia NH ₃	0,003	0,005
Chlorine Cl ₂	N/A	N/A
Fluorine F ₂	N/A	N/A
hydrogen sulphide H ₂ S	0,006	N/A
Sulfide dioxide SO ₂	N/A	N/A
Dust, mg/m ³	<1	2
Moisture, mg/m ³	1320	2410

Analysis person in charge signed B.I.Koshovskiy

JI MONITORING REPORT FORM

Monitoring Report #6 "Utilization of Coal Mine Methane at the Coal Mine named after A.F. Zasyadko" page 40

APPROVED
 P.S.Pashkovskiy
 First Director Deputy, Science
 Activity, Dr. Sc. < signature >
 Seal
 The 17th of February, 2009

Percentage of matters in fuel gas and ignition gas samples taken on 06.02.09
 at Lease Enterprise Mine named after A.F.Zasyadko

Main components	Fuel Gas, Concentration, %	Ignition Gas, Concentration, %
Methane CH ₄	29,7	97,2
Ethan C ₂ H ₆	0,15	0,7
Propane C ₃ H ₈	0,05	0,05
Butane C ₄ H ₁₀	0,004	0,001
Pentane C ₅ H ₁₂	0,001	0,007
Hexane C ₆ H ₁₄	0,0004	0,0006
Carbon Oxide CO	0,0003	0,004
Hydrogen H ₂	0,06	0,03
Carbon Dioxide CO ₂	0,05	N/A
Nitrogen N ₂	53,5	1,2
Oxygen O ₂	14,6	0,3
Argon Ar	0,56	N/A
Micro-Components	mg/Nm³	
Ammonia NH ₃	N/A	N/A
Chlorine Cl ₂	N/A	N/A
Fluorine F ₂	N/A	N/A
hydrogen sulphide H ₂ S	0,03	N/A
Sulfide dioxide SO ₂	N/A	N/A
Dust, mg/m ³	<1	2
Moisture, mg/m ³	2120	1640

* recalculated per dry gas

Analysis person in charge signed B.I.Koshovskiy

JI MONITORING REPORT FORM

Monitoring Report #6 "Utilization of Coal Mine Methane at the Coal Mine named after A.F. Zasyadko" page 41

Gas sample analysis – 2nd quarter 2009

APPROVED
P.S.Pashkovskiy
First Director Deputy, Science
Activity, Dr. Sc. < signature >
Seal
The 1st of June, 2009

Percentage of matters in samples of gas taken on 22.05.09
at Lease Enterprise Mine named after A.F.Zasyadko

Main components	Sampling point	
	Vacuum Pump Station-4	
	First Group	Second Group
	Concentration, %	Concentration, %
Methane CH ₄	13,9	35,6
Ethan C ₂ H ₆	0,05	0,2
Propane C ₃ H ₈	0,0019	0,02
Butane C ₄ H ₁₀	0,002	0,001
Pentane C ₅ H ₁₂	N/A	N/A
Hexane C ₆ H ₁₄	N/A	N/A
Carbon Oxide CO	N/A	0,0006
Hydrogen H ₂	N/A	0,03
Carbon Dioxide CO ₂	0,08	0,06
Nitrogen N ₂	68,5	51,7
Oxygen O ₂	14,6	11,9
Argon Ar	0,82	0,55
Micro-Components	mg/Nm³	
Ammonia NH ₃	0,002	N/A
Chlorine Cl ₂	N/A	N/A
Fluorine F ₂	N/A	N/A
hydrogen sulphide H ₂ S	0,004	N/A
Sulfide dioxide SO ₂	N/A	N/A
Dust, mg/m ³	<1	<1
Moisture, mg/m ³	1580	2620

Analysis person in charge signed B.I.Koshovskiy

JI MONITORING REPORT FORM

Monitoring Report #6 "Utilization of Coal Mine Methane at the Coal Mine named after A.F. Zasyadko" page 42

APPROVED
 P.S.Pashkovskiy
 First Director Deputy, Science
 Activity, Dr. Sc. < signature >
 Seal
 The 1st of June, 2009

Percentage of matters in fuel gas and ignition gas samples taken on 22.05.09
 at Lease Enterprise Mine named after A.F.Zasyadko

Main components	Fuel Gas, Concentration, %	Ignition Gas, Concentration, %
Methane CH ₄	29,2	96,5
Ethan C ₂ H ₆	0,11	0,6
Propane C ₃ H ₈	0,06	0,07
Butane C ₄ H ₁₀	0,005	0,001
Pentane C ₅ H ₁₂	0,001	0,005
Hexane C ₆ H ₁₄	0,0006	0,0005
Carbon Oxide CO	0,0002	0,006
Hydrogen H ₂	0,08	0,02
Carbon Dioxide CO ₂	0,04	N/A
Nitrogen N ₂	53,8	1,6
Oxygen O ₂	14,9	0,4
Argon Ar	0,54	N/A
Micro-Components	mg/Nm³	
Ammonia NH ₃	N/A	N/A
Chlorine Cl ₂	N/A	N/A
Fluorine F ₂	N/A	N/A
hydrogen sulphide H ₂ S	0,05	N/A
Sulfide dioxide SO ₂	N/A	N/A
Dust, mg/m ³	<1	2
Moisture, mg/m ³	1890	1530

* recalculated per dry gas

Analysis person in charge signed B.I.Koshovskiy

JI MONITORING REPORT FORM

Monitoring Report #6 "Utilization of Coal Mine Methane at the Coal Mine named after A.F. Zasyadko" page 43

Gas sample analysis – 3d quarter 2009

APPROVED
 P.S.Pashkovskiy
 First Director Deputy, Science
 Activity, Dr. Sc. < signature >
 Seal
 The September 18, 2009

Percentage of matters in samples of gas taken on 23.08.09
 at Lease Enterprise Mine named after A.F.Zasyadko

Main Components	Sampling Point		
	Vacuum Pump Station-1		Vacuum Pump Station -2
	First group	Second group	Second group
	Concentration, %		Concentration, %
Methane CH ₄	15,3	15,3	32,8
Ethan C ₂ H ₆	0,07	0,07	0,3
Propane C ₃ H ₈	0,0015	0,0015	0,04
Butane C ₄ H ₁₀	0,004	0,004	0,002
Pentane C ₅ H ₁₂	N/A	N/A	N/A
Hexane C ₆ H ₁₄	N/A	N/A	N/A
Carbon Oxide CO	N/A	N/A	0,0006
Hydrogen H ₂	N/A	N/A	0,04
Carbon Dioxide CO ₂	0,09	0,09	0,04
Nitrogen N ₂	66,9	66,9	53,2
Oxygen O ₂	13,7	13,7	12,8
Argon Ar	0,79	0,79	0,49
Micro-Components	mg/Nm³		
Ammonia NH ₃	0,001	0,001	N/A
Chlorine Cl ₂	N/A	N/A	N/A
Fluorine F ₂	N/A	N/A	N/A
hydrogen sulphide H ₂ S	0,006	0,006	N/A
Sulfide dioxide SO ₂	N/A	N/A	N/A
Dust, mg/m ³	<1	<1	<1
Moisture, mg/m ³	1930	1930	2760

Vacuum Pump Station -4 — first and second group are combined in one common degasification line

* recalculated per dry gas

Analysis person in charge signed B.I.Koshovskiy

JI MONITORING REPORT FORM

Monitoring Report #6 "Utilization of Coal Mine Methane at the Coal Mine named after A.F. Zasyadko" page 44

APPROVED
 P.S.Pashkovskiy
 First Director Deputy, Science
 Activity, Dr. Sc. <signature>
 Seal
 The September 18, 2009

Percentage of matters in fuel gas and ignition gas samples taken on 23.08.09
 at Lease Enterprise Mine named after A.F.Zasyadko

<u>Main Components</u>	Fuel Gas, Concentration, %	Ignition Gas, Concentration, %
Methane CH ₄	33,2	97,2
Ethan C ₂ H ₆	0,18	0,7
Propane C ₃ H ₈	0,04	0,05
Butane C ₄ H ₁₀	0,004	0,004
Pentane C ₅ H ₁₂	0,003	0,008
Hexane C ₆ H ₁₄	0,0003	0,0003
Carbon Oxide CO	0,0006	0,002
Hydrogen H ₂	0,06	0,05
Carbon Dioxide CO ₂	0,08	N/A
Nitrogen N ₂	51,9	1,1
Oxygen O ₂	12,7	0,28
Argon Ar	0,39	N/A
Micro-Components	mg/Nm³	
Ammonia NH ₃	N/A	N/A
Chlorine Cl ₂	N/A	N/A
Fluorine F ₂	N/A	N/A
hydrogen sulphide H ₂ S	0,04	N/A
Sulfide dioxide SO ₂	N/A	N/A
Dust, mg/m ³	<1	2
Moisture, mg/m ³	2350	1930

* recalculated per dry gas

Analysis person in charge signed B.I.Koshovskiy