

**JI MONITORING REPORT**

**FOR REPORTING PERIOD 01.02.2010 – 31.07.2010**

**Version 2.0**  
**9<sup>th</sup> of September 2010**

**CONTENTS**

- A. General project activity and monitoring information
- B. Key monitoring activities
- C. Quality assurance and quality control measures
- D. Calculation of GHG emission reductions

**SECTION A. General Project activity information**

**A.1 Title of the project activity:**

“Utilization of Coal Mine Methane at the Coal Mine named after A.F. Zasyadko”.

**A.2. Registration number at JISC:**

UA2000004

**A.3. Short description of the project activity:**

According to data of the mine, during six months (01.02.2010 — 31.07.2010) the following amount of methane has been utilized:

For electricity (and heat) m <sup>3</sup> ( fuel gas)	26 416 814
For electricity (and heat) m <sup>3</sup> ( ignition gas)	1 108 380
For AGFCP m <sup>3</sup>	925 449
Total	28 450 643

*Table 1: Amount of methane utilized during monitoring period.*

The project is aimed to prevent emission of methane into atmosphere at Lease Enterprise Zasyadko Coal Mine, further referred to as Zasyadko or simply Mine. CMM extracted and recovered during mine works and because of ventilation of Mine, obtained from surface wells drilled into the gob at Zasyadko Coal Mine, is utilized for:

- Power production;
- Replacement of heat that is now generated by coal and gas boilers;
- Production of gas for motor vehicle fuelling.

Mine has four industrial sites: Vostochnaya, Yakovlevskaya, Centralnaya and Grigoryevskaya. During this monitoring period, one CHP at Vostochnaya site was in operation. The power generated at CHP was supplied in Mine's main, for Mine's local consumption. Heat generated by Vostochnaya CHP was feed for consumption at Vostochnaya site. Double-block automatic gas filling station at Vostochnaya site supply car fleet of Mine and other vehicles from neighbouring districts with fuel.

In the future, commissioning of the second CHP at Yakovlevskaya site is intended, and heat supply grid as well. This will make Mine able to feed excess power to general consumption grid, supply heat to Vostochnaya, Yakovlevskaya, and Centralnaya sites, and municipal heat supply grid. Besides, gas fuelling stations will be installed at Yakovlevskaya site.

**A.4. Monitoring period:**

- Monitoring period starting date: 01/02/2010;
- Monitoring period closing date: 31/07/2010<sup>1</sup>.

**A.5. Methodology applied to the project activity (incl. version number):**

**A.5.1. Baseline methodology:**

The approved consolidated methodology ACM0008/Version 03 “*Consolidated baseline methodology for coal bed methane and coal mine methane capture and use for power (electrical or motive) and heat and/or destruction by flaring*”) has been used to identify the baseline scenario of this JI project. This methodology also refers to the “Tool for calculation of emission factor for electricity systems”, the latest version of the “Tool for the demonstration and assessment of additionality” and the latest version of the “Tool to determine project emissions from flaring gases containing methane”.

<sup>1</sup> Both days were included. Monitoring period includes time from 00-00 01/02/10 up to 24-00 31/07/10.

**A.5.2. Monitoring methodology:**

The approved consolidated methodology ACM0008/Version 03 “*Consolidated baseline methodology for coal bed methane and coal mine methane capture and use for power (electrical or motive) and heat and/or destruction by flaring*”) has been used to identify the baseline scenario of this JI project.

**A.6. Status of implementation including timetable for major project parts:**

Activity	Date
Commissioning of blocks (No.1, No.2) at gas filling compressor stations at Vostochnaya site	March 2004
Commissioning of new block No.3 at gas filling compressor station at Vostochnaya site	March 2005
Commissioning of the 1 <sup>st</sup> CHP modules at Vostochnaya site	January 2006
Commissioning of the 12 <sup>th</sup> CHP modules at Vostochnaya site	April 2006
Shut-down of boilers at Vostochnaya site	September 2006
Construction of vacuum pump station N 4 at Grigoryevskaya shaft with six vacuum pumps VVN-150 and build up 3 pipe lines	March 2007
Heat feeding from CHP units to, and shutdown of the boilers at Grigoryevskaya site	December 2011
Heat feeding from CHP units to, and shutdown of the boilers at Yakovlevskaya site	October 2010
Commissioning of the 1 <sup>st</sup> CHP unit at Yakovlevskaya site	December 2010
Commissioning of 6 CHP units at Yakovlevskaya site	December 2011
Heat supply to district heat supply system	December 2012

*Table 2: Status of implementation (according to PDD version 4.4)*

**A.7. Intended deviations or revisions to the registered PDD:**

There are no deviations from final version of PDD approved by JISC. A delay in the implementation schedule was noted as compared with implementation schedule from PDD as shown above. In view of this, within the monitoring period, following project parts were not introduced:

- Power: Yakovlevskaya CHP is not in operation at this moment. At this CHP, power generation is not running; as a result,  $GEN_{CHP}$  includes only net power generated by Vostochnaya CHP;
- Heat: during this monitoring period, infrastructure for heat supply of four sites of Mine and municipal heat supply grid are absent, save heat supply from Vostochnaya CHP to Vostochnaya site. In view of this, at this monitoring period, monitoring of following variable data was not performed:  $HEAT_{deliv, DH, y}$ ;  $HEAT_{deliv, yak, y}$ ;  $HEAT_{deliv, centr, y}$ . General amount of heat supplied is equal to amount of heat supplied from Vostochnaya CHP ( $HEAT_{deliv, vost, y}$ );
- Coal Mine Methane(CMM), utilized at CHP: As Yakovlevskaya CHP was not in operation during this monitoring period, CMM was not utilized at this CHP. Therefore,  $MM_{CHP, y}$  included only CMM, utilized by Vostochnaya CHP;
- Coal Mine Methane(CMM) utilized at AGFCP. From five planned fuel stations (one- at Vostochnaya site, one- at Centralnaya site, and two- on Yakovlevskaya site), during this monitoring period, block gas filling station at Vostochnaya site has been operating. Therefore for  $MM_{GAS, y}$  monitoring, only gas supply to these gas fueling station was used.

**A.8. Intended deviations or revisions to the registered monitoring plan (Decision 17/CP.7, Annex H, paragraph 57 to be considered):**

There are no deviations in the monitoring plan compared to the final monitoring plan dd. 27 March 2008 as described in the PDD version 4.4. Below –mentioned metering devices have been substituted, and additions have been made to provide safety of parameters monitored. Calibration of all these devices has been performed (see below). Parameters as well as formulas have not been changed.

## JI MONITORING REPORT

---

**Monitoring Report #8** "Utilization of Coal Mine Methane at the Coal Mine named after A.F. Zasyadko" page 4

From January 1, 2008, primary and secondary metering devices/ meters have been added/ substituted, because CHP unit measuring system was updated and improved. In addition, new metering device blocks for high concentration flow metering measurement have been installed:

- Universal 1 Metering system for ignition gas at CHP unit instead of Gn6 with their sensors;
- Universal 2 Metering system for fuel gas at AGFCP, additionally to gas fuelling stations equipment;
- BKTМ Metering system for fuel gas in machine rooms, instead of Keuter device, ADM Electronic at gas treatment facility.

See more detailed description of layout and work of metering equipment in Section B.

### **A.9. Changes since last verification:**

During 01/02/2010-31/07/2010, no changes occurred since last verification.

### **A.10. Person(s) responsible for the preparation and submission of the monitoring report:**

Lease enterprise "Coal Mine named after A.F. Zasyadko

- Boris Bokiу, Deputy General Director
- Yevgeniy Berezovskiy, CHP Chief;
- Valeriy Cherednikov, Monitoring Engineer, Gas Treatment Lead Engineer;

LLC "Carbon Emissions Partnership Technic".

- Svitlana Lyubarets, Director.

**SECTION B. Key monitoring activities according to the monitoring plan for the monitoring period stated in A.4.**

The control and monitoring system can be divided into an electrical part, a heat part and a gas part.

**Electrical measurements**

There are no changes since last monitoring period.

**Heat measurements**

There are no changes since last monitoring period.

**B.1. Monitoring equipment types**

There are no changes since last monitoring period.

1. Electricity meters “Elster-Metronika”;
2. Heat meter SA-94/2 M;
3. Gas Analyzer ABB A02040 (for fuel and ignition methane);
4. DBT equipment. (for fuel and ignition methane);
5. DRGM flow meters (for fuel methane) as a part of BKTМ metering systems;
6. Metering system “Universal”.

**B.1.2. Table providing information on metering equipment used (incl. manufacturer, type, serial number, date of installation, Date of calibration, information to specific uncertainty, need for changes and replacements):**

The control and monitoring system can be divided into an electrical part, a heat part, and a gas part.

**Electrical measurements**

Following parameters shall be measured for emission reduction monitoring<sup>2</sup>:

- $GEN_{CHP}$  — net electricity generated by CHP under project(MWh);
- $El_{cons}$  — net electricity consumed by Mine (MWh)<sup>3</sup>.

According to monitoring plan, initially excess or lack of net electricity amount was checked as generated by CHP in comparison to net electricity consumed by Mine. Actually, parameters measured are:

- $GEN_{CHP} = 91\,927,209$  MWh;
- $EL_{cons} = 104\,129,241$  MWh.

As net electricity amount generated by CHP under project is less than net electricity consumed by Mine, for emission reduction monitoring (see also page 40 of PDD), only amount of electricity generated by CHP is required. Net electricity generated by CHP is measured with two meters in power grid of Mine:

$$GEN_{CHP}(MWh) = E1 + E2 \tag{1.}$$

To perform cross-checking, electricity generated by CHP is summed up by way of addition of total electricity amount generated by each separate CHP unit excluding secondary electricity consumption by CHP itself. This calculation is performed under following formula.

$$GEN_{CHP} = \left( \sum_5^{16} E_{mod} - \sum_3^4 E_{aux} \right) = (E5 + E6 + E7 + E8 + E9 + E10 + E11 + E12 + E14 + E15 + E16) - (E3 + E4) \tag{2.}$$

Respective description of meters see in the table provided below. Because for check of electricity at high voltage, it is impossible to use data directly from meters, current and voltage transformers are used. In the first table, converted data for calculation of actual data are shown.

<sup>2</sup> Section D contains respective formulae from Monitoring Plan of PDD.

<sup>3</sup> Net electricity consumption of Mine is demonstrated in the report of Chief Energy Engineer of the Mine according to data of thirteen commercial meters located at other 110 kV substations at Mine named after A.F.Zasyadko. Meters E17, E18 are included in thirteen commercial meters and are located at Vostochnaya substation 110 kV.

## JI MONITORING REPORT

Accounting of electricity generated by CHP is fixed by automated electricity commercial recording system (AECRS) which included twelve EuroALPHA non-commercial E-meters (E5 — E16), which record generation of each genset, as well as two EuroALPHA onon-commercial E-meters (E3 — E4), that record CHP consumption.

Each genset cell is provided with universal microprocessor protection and control devices (REF), which allow, among other functions, performance of technical recording of electricity amount. Data from REF are hourly fixed in the database. Upon expiry of the day, hourly generation per each genset is fixed.

CHP Chief Dispatcher performs daily comparison of readings of AECRS and REF.

Summary crosschecking results from 01.02.2010 until 31.07.2010 are shown in the table.

<b>01.02.2010 - 31.07.2010</b>			
<b>Months</b>	<b>Active power generation AECRS</b>	<b>Active power generation REF</b>	<b>Relative difference in AECRS-REF readings</b>
	<b>kWh</b>	<b>kWh</b>	<b>%</b>
<b>Febuary 2010</b>	13 288 413	13 273 674	0,11
<b>March 2010</b>	16 419 396	16 402 799	0,10
<b>April 2010</b>	16 655 910	16 635 869	0,12
<b>May 2010</b>	16 026 950	16 012 820	0,09
<b>June 2010</b>	17 077 698	17 067 085	0,06
<b>July 2010</b>	15 861 803	15 853 488	0,05
<b>Total</b>	<b>107 461 892</b>	<b>107 366 112</b>	<b>0,09</b>

Table 3. AECRS - REF Summary Crosschecking Results

## JI MONITORING REPORT

### Electricity Meters

Number	Metering instrument	Work parameter kWh, kVar	Manufacturer	Type	Serial Number	Accuracy <sup>4</sup>	Date of installation	Date 01.02.2010	Date 31.07.2010	Difference	Date of calibration	Date of next calibr.	Remarks
E1	Electricity meter at CHP system (6 kV) Wireway	Net electricity generated by CHP system. P,Q	“Elster-Metronika” Russia	Electronic	№ 01116374	0.2S <sup>5</sup>	N/A	7033,8674	8268,5466	1234,6792	14.05.2005	14.05.2011	Double side. Cubicle No.A21
E2	Electricity meter at CHP system (6 kV) Wireway	Net electricity generated by CHP system. P,Q	“Elster-Metronika” Russia	Electronic	№ 01116376	0.2S	N/A	7419,9454	8617,2029	1197,2575	14.05.2005	14.05.2011	Double side. Cubicle No.B22
E17	Commercial electricity meter 110 kV	Consumption of electricity from or supply Ukrainian grid with	“Elster-Metronika” Russia	Electronic	№ 01194835	0.2S	N/A	182,1430	191,6990	9,5560	N/A Belongs to supply company	N/A	Substation 110kV T1
E18	Commercial electricity meter 110 kV	Consumption of electricity from or supply Ukrainian grid with	“Elster-Metronika” Russia	Electronic	№ 01194834	0.2S	N/A	120,9750	139,9940	19,0190	N/A Belongs to supply company	N/A	Substation 110kV T2

<sup>4</sup> Accuracy level is a generalized parameter of measurement devices that is defined with limits of allowable main and extra uncertainties, as well as with range of other properties that influence accuracy of measurements performed with them. Accuracy levels are regulated by norms for certain types of measurement devices with use of metrological parameters and methods of their normalization.

<sup>5</sup> Accuracy levels 0.2S and 0.5S; letter S means that meter accuracy is normalized commencing from lower limit not in 5% of Ином (nominal limit) (as the case is for meters with no letter, e.g. levels 0,2 and 0,5), but from 1% of Ином, according to GOST 30206-94.

## JI MONITORING REPORT

Monitoring Report #8 “Utilization of Coal Mine Methane at the Coal Mine named after A.F. Zasyadko” page 8

Number	Metering instrument	Work parameter kWh, kVar	Manufacturer	Type	Serial Number	Accuracy	Date of installation	Date 01.02.2010	Date 31.07.2010	Difference	Date of calibration	Date of next calibr.	Remarks
E3	Electricity meter at CHP system (6 kV) Auxiliary transformer	Electricity consumed by CHP system, P, Q	“Elster-Metronika” Russia	Electronic	№ 01103251	0.5S	N/A	3752,4880	4345,4587	592,9707	03.09.2004 14.04.2010	14.04.2016	Cubicle No.1
E4	Electricity meter at CHP system (6 kV) Auxiliary transformer	Electricity consumed by CHP system, P, Q	“Elster-Metronika” Russia	Electronic	№ 01103208	0.5S	N/A	3822,1797	4407,7161	585,5364	03.09.2004 14.04.2010	14.04.2016	Cubicle No.2
E5	Electricity meters at individual CHP modules (6 kV) No.1	Gross electricity generated by CHP system P,Q	“Elster-Metronika” Russia	Electronic	№ 01117846	0.2S	N/A	8129,5781	9796,4711	1666,8930	16.06.2005 14.04.2010	14.04.2016	Double side. Cubicle No.5
E6	Electricity meters at individual CHP modules (6 kV) No.3	Gross electricity generated by CHP system P,Q	“Elster-Metronika” Russia	Electronic	№ 01117849	0.2S	N/A	9098,6994	10721,1073	1622,4079	16.06.2005 12.04.2010	12.04.2016	Double side. Cubicle No.7
E7	Electricity meters at individual CHP modules (6 kV) No.5	Gross electricity generated by CHP system P,Q	“Elster-Metronika” Russia	Electronic	№ 01117851	0.2S	N/A	9527,5425	10905,0278	1377,4853	16.06.2005 07.04.2010	07.04.2016	Double side. Cubicle No.9
E8	Electricity meters at individual CHP modules (6 kV) No.7	Gross electricity generated by CHP system P,Q	“Elster-Metronika” Russia	Electronic	№ 01117852	0.2S	N/A	8841,6374	10391,1110	1549,4736	16.06.2005 13.04.2010	13.04.2016	Double side. Cubicle No.11
E9	Electricity meters at individual CHP modules (6 kV) No.9	Gross electricity generated by CHP system P,Q	“Elster-Metronika” Russia	Electronic	№ 01117855	0.2S	N/A	10310,7592	11922,6261	1611,8669	16.06.2005 13.04.2010	13.04.2016	Double side. Cubicle No.13
E10	Electricity meters at individual CHP modules (6 kV) No.11	Gross electricity generated by CHP system P,Q	“Elster-Metronika” Russia	Electronic	№ 01117856	0.2S	N/A	9995,2307	11484,2372	1489,0065	16.06.2005 07.04.2010	07.04.2016	Double side. Cubicle No.15



## JI MONITORING REPORT

Monitoring Report #8 "Utilization of Coal Mine Methane at the Coal Mine named after A.F. Zasyadko" page 9

Number	Metering instrument	Work parameter kWh, kVar	Manufacturer	Type	Serial Number	Accuracy	Date of installation	Date 01.02.2010	Date 31.07.2010	Difference	Date of calibration	Date of next calibr.	Remarks
E11	Electricity meters at individual CHP modules (6 kV) No.2	Electricity consumed by CHP system, P, Q	"Elster-Metronika" Russia	Electronic	№ 01117848	0.2S	N/A	10576,8271	12161,7203	1584,8932	16.06.2005 12.04.2010	12.04.2016	Cubicle No.6
E12	Electricity meters at individual CHP modules (6 kV) No.4	Electricity consumed by CHP system, P, Q	"Elster-Metronika" Russia	Electronic	№ 01122645	0.2S	N/A	5768,3828	7133,9699	1365,5871	10.08.2005 12.04.2010	12.04.2016	Cubicle No.8
E13	Electricity meters at individual CHP modules (6 kV) No.6	Gross electricity generated by CHP system P,Q	"Elster-Metronika" Russia	Electronic	№ 01122650	0.2S	N/A	9159,4363	10960,8803	1801,4440	10.08.2005 14.04.2010	14.04.2016	Double side. Cubicle No.10
E14	Electricity meters at individual CHP modules (6 kV) No.8	Gross electricity generated by CHP system P,Q	"Elster-Metronika" Russia	Electronic	№ 01117845	0.2S	N/A	11296,2496	13013,0723	1716,8227	16.06.2005 07.04.2010	07.04.2016	Double side. Cubicle No.12
E15	Electricity meters at individual CHP modules (6 kV) No.10	Gross electricity generated by CHP system P,Q	"Elster-Metronika" Russia	Electronic	№ 01132765	0.2S	N/A	10381,2932	11879,0399	1497,7467	09.02.2006 13.04.2010	13.04.2016	Double side. Cubicle No.14
E16	Electricity meters at individual CHP modules (6 kV) No.12	Gross electricity generated by CHP system P,Q	"Elster-Metronika" Russia	Electronic	№ 01132766	0.2S	N/A	6931,0261	8562,1111	1631,0850	09.02.2006 14.04.2010	14.04.2016	Double side. Cubicle No.16

Calibration interval for electricity meters is six years.

As it is impossible to use meters data directly to check electricity generated we have to take in account special coefficients which is appears from multiplying of coefficients transformation for current and voltage transformers connected to each meter. Their data are presented in table below.

In view of high voltage and currents, it is impossible to obtain direct data from electricity meters on generation and consumption of electricity without current and voltage transformers, for accounting of equipment operation. The calculation method is following: example for meter No. 01116374: Current  $-3000/5= 600$  A; voltage-  $6300/100=63$  V (gross factor  $-600 \times 63 =37800$  VA). *Date on meter -1234,6792. Electricity to be accounted with this meter makes up:  $1234,6792 \times 600 \times 63=46\ 670\ 873,8$  VA = 46 670 873,8 kW*

## JI MONITORING REPORT

Number	Metering instrument	Work parameter kWh, kVar	Type	Serial Number	Current transformer	Voltage transformer	Coefficient for calculations	Electricity Amount
E1	Electricity meter at CHP system (6 kV) Wireway	Net electricity generated by CHP system, P,Q	Electronic	№ 01116374	3000/5	6300/100	37800	46 670 873,8
E2	Electricity meter at CHP system (6 kV) Wireway	Net electricity generated by CHP system, P,Q	Electronic	№ 01116376	3000/5	6300/100	37800	45 256 333,5
E3	Electricity meter at CHP system (6 kV) Auxiliary transformer	Electricity consumed by CHP system, P, Q	Electronic	№ 01103251	200/5	6300/100	2520	1 494 286,2
E4	Electricity meter at CHP system (6 kV) Auxiliary transformer	Electricity consumed by CHP system, P, Q	Electronic	№ 01103208	200/5	6300/100	2520	1 475 551,7
E5	Electricity meters at individual CHP modules (6 kV) No.1	Gross electricity generated by CHP system, P,Q	Electronic	№ 01117846	400/5	6300/100	5040	8 401 140,7
E6	Electricity meters at individual CHP modules (6 kV) No.3	Gross electricity generated by CHP system P,Q	Electronic	№ 01117849	400/5	6300/100	5040	8 176 935,8
E7	Electricity meters at individual CHP modules (6 kV) No.5	Gross electricity generated by CHP system P,Q	Electronic	№ 01117851	400/5	6300/100	5040	6 942 525,9
E8	Electricity meters at individual CHP modules (6 kV) No.7	Gross electricity generated by CHP system P,Q	Electronic	№ 01117852	400/5	6300/100	5040	7 809 346,9
E9	Electricity meters at individual CHP modules (6 kV) No.9	Gross electricity generated by CHP system P,Q	Electronic	№ 01117855	400/5	6300/100	5040	8 123 809,2
E10	Electricity meters at individual CHP modules (6 kV) No.11	Gross electricity generated by CHP system P,Q	Electronic	№ 01117856	400/5	6300/100	5040	7 504 592,8
E11	Electricity meters at individual CHP modules (6 kV) No.2	Gross electricity generated by CHP system P,Q	Electronic	№ 1117848	400/5	6300/100	5040	7 987 861,7
E12	Electricity meters at individual CHP modules (6 kV) No.4	Gross electricity generated by CHP system P,Q	Electronic	№ 01122645	400/5	6300/100	5040	6 882 559,0

## JI MONITORING REPORT

Number	Metering instrument	Work parameter kWh, kVar	Type	Serial Number	Current transformer	Voltage transformer	Coefficient for calculations	Electricity Amount
E13	Electricity meters at individual CHP modules (6 kV) No.6	Net electricity generated by CHP system, P,Q	Electronic	№ 01122650	400/5	6300/100	5040	9 079 277,8
E14	Electricity meters at individual CHP modules (6 kV) No.8	Net electricity generated by CHP system, P,Q	Electronic	№ 01117845	400/5	6300/100	5040	8 652 786,4
E15	Electricity meters at individual CHP modules (6 kV) No.10	Net electricity generated by CHP system, P,Q	Electronic	№ 01132765	400/5	6300/100	5040	7 548 643,4
E16	Electricity meters at individual CHP modules (6 kV) No.12	Net electricity generated by CHP system, P,Q	Electronic	№ 01132766	400/5	6300/100	5040	8 220 668,4
E17	Commercial electricity meter 110 kV	Consumption of electricity from or supply Ukrainian grid with	Electronic	№ 01194835	150/5	110000/100	33000	315 348,0
E18	Commercial electricity meter 110 kV	Consumption of electricity from or supply Ukrainian grid with	Electronic	№ 01194834	150/5	110000/100	33000	627 627,0

Electricity Metering Scheme for Vostochnaya CHP Facility

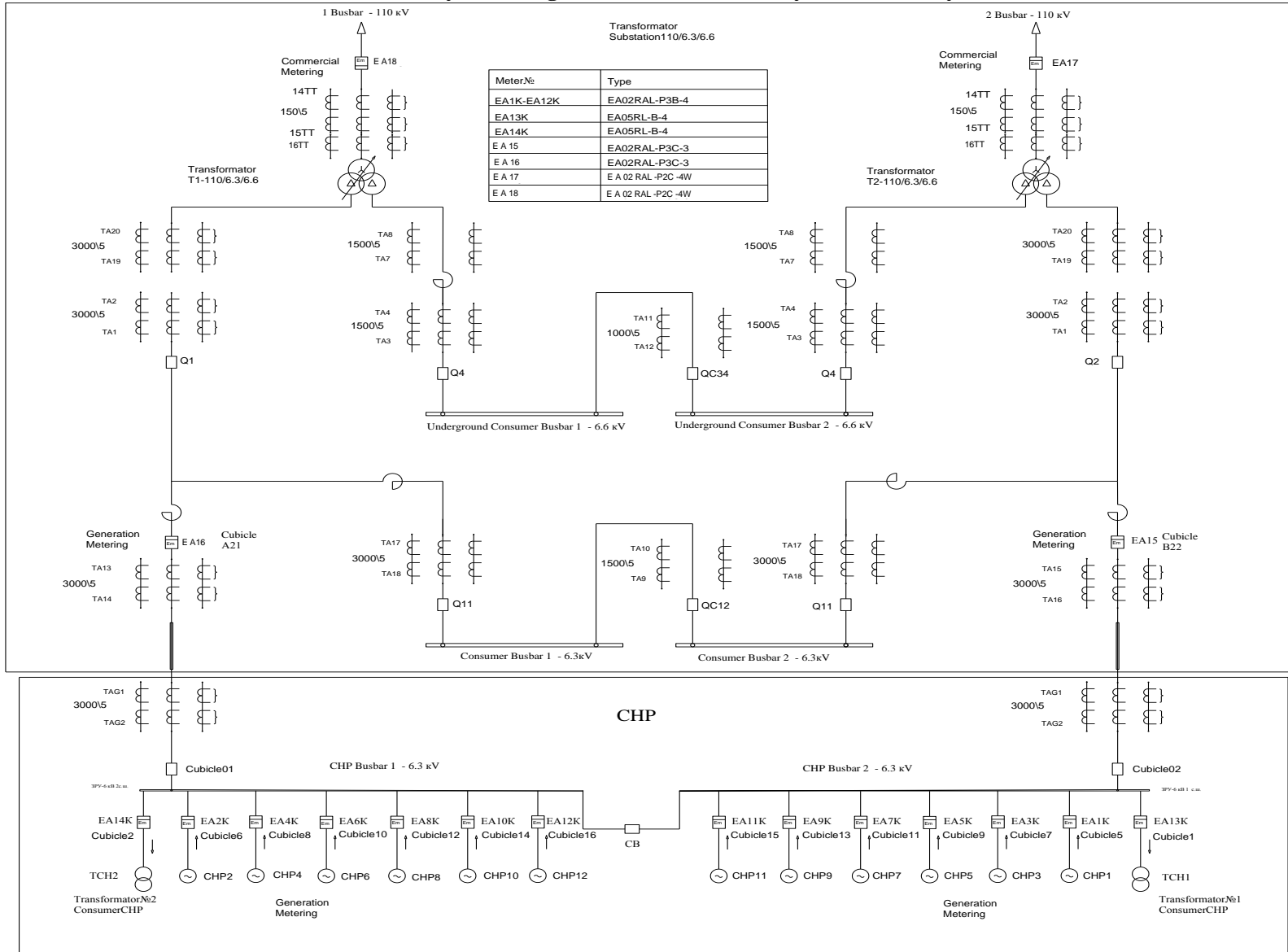

Figure 1: Electricity Metering Scheme for Vostochnaya CHP

## JI MONITORING REPORT

### Heat Meter Heat measurements

For this monitoring period, only heat is considered that was directly fed by Vostochnaya CHP, as described in paragraph A.7. Therefore, for this monitoring period, only one variable is measured that expresses heat amount fed by CHP system to heat supply pipelines, and is equal to heat amount consumed by Vostochnaya site.

Metering instrument	Work parameter Gcal	Manufacturer	Type	Serial number	accuracy	Date of installation	Date 01.02.2010 Gcal	Date 31.07.2010 Gcal	Difference	Date of calibration	Date of next calibr.	Remarks
Heat meter SA 94/2M <sup>6</sup>	Amount of heat delivered to site system	ASWEGA	Mechatronic	22903	Heat- 4 Flow-2	N/A	110 890,89	134 119,81	23 228,92	04.06.09	04.06.11	T,V,Q (Total )

Calibration interval for heat meters is two years

<sup>6</sup> For meter SA 94/2M DN=300mm; Q=1000m<sup>3</sup>/h

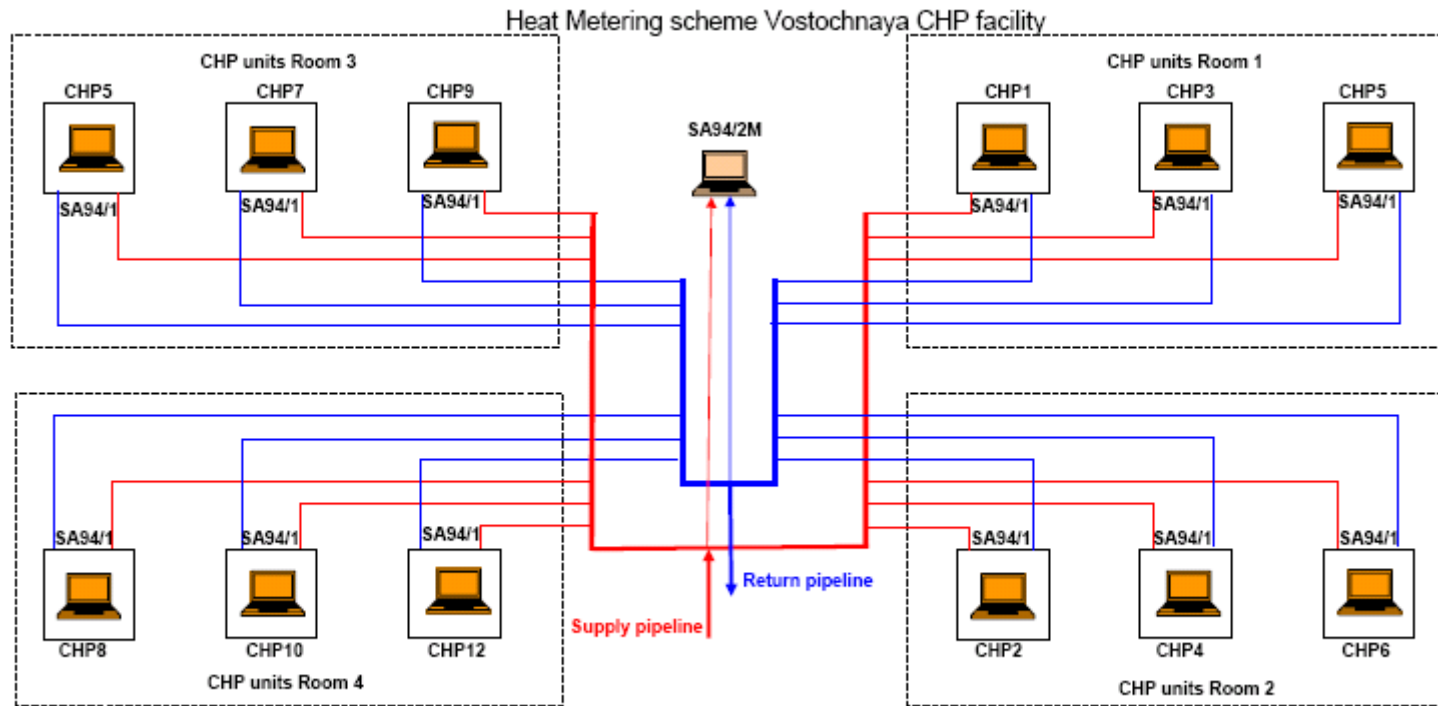

Figure 2: Heat Metering Scheme for Vostochnaya CHP Facility

CMM Meters

**Measurement of CMM consumption**

According to monitoring plan, two variables are measured:

- MM<sub>CHP</sub>- measured amount of methane fed to CHP units (tCH<sub>4</sub>);
- MM<sub>GAS</sub>- measured amount of methane fuelled in vehicles at new automotive gas filling stations (tCH<sub>4</sub>).

Variable MM<sub>CHP</sub> has two components: fuel gas consumption and ignition gas consumption. To determine the amount of pure consumed CH<sub>4</sub> (in tonnes) the amount of pure CH<sub>4</sub> (in m<sup>3</sup>) has to be measured under normal conditions<sup>7</sup>. The amount of pure CH<sub>4</sub> (in m<sup>3</sup>) can be measured (or more correctly: calculated) based on four parameters:

- Concentration (%) of CH<sub>4</sub> in the gas mixture
- Flow (m<sup>3</sup>) of gas mixture
- Temperature (°C) of gas mixture
- Pressure (bar) of gas mixture

In the scheme below the different meters and sensors are indicated that are installed at the Vostochnaya site. We can classify the different meters/sensors:

- Scheme of location of main primary meters/sensors that supply the data for determining the emission reductions as provided in section D of the Monitoring Report;
- General scheme of location of meters/sensors (with addition of secondary meters/ sensors) used for cross-checking the data of the primary meters, as well as meters/sensors used to operated and control the installation.

The secondary meters/sensors are not of interest for monitoring purposes and are not mentioned further. In the table below the primary and secondary meters/sensors are indicated with their number which listed in the scheme.

	Primary meters/sensors	Secondary meters/sensors
<b>Fuel gas</b>		
Concentration (%)	ABB AO 2040 (A1)	K1-K6
Flow (V)	G1-G12	Gn1-Gn6
Temperature (T)	T6-T17	Gn5 sensor
Pressure (P)	P11-P22	P6(Gn5's sensor)
Unit for methane keeping (m3)	BKT.M <sup>8</sup> metering system	DBT equipment
<b>Ignition gas</b>		
Concentration (%)	ABB AO 2040 (A2)	ABB AO 2040 (A2)
Flow (V)	G13	
Temperature (T)	T2	
Pressure (P)	P10	
Unit for methane keeping (m3)	"Universal" <sup>9</sup> metering system	Pressure sensors on pipeline
<b>AGFCP gas</b>		
Concentration (%)	ABB AO 2040 (A2)	ABB AO 2040 (A2)
Flow (V)	G14	Calculations according to pressure difference
Temperature (T)	T1	
Pressure (P)	P5	Manometers at AGFCS
Unit for methane keeping (m3)	"Universal" <sup>9</sup> metering system	Calculations

Table 4: Primary and secondary (cross-checking) metering of CMM

<sup>7</sup> Normal conditions=273K and 760 mm Hg.

<sup>8</sup> BKT.M is designed for conversion of input data of gas parameters and calculation on the base thereof of amount and volumetric gas flow brought to standard conditions, in the composition of DRG.M meter.

<sup>9</sup> Universal is designed for conversion of input data of gas parameters and calculation on the base thereof of amount and volumetric gas flow brought to standard conditions.

$MM_{CHP}$  – is an amount of fuel gas consumption at each CHP unit, including one ignition gas metering device, represented as following:

$$MM_{CHP} = \left( \sum_1^{12} VM_n \cdot C_1 + V_1 \cdot C_2 \right) \cdot 0,7167 \cdot 0,93, \quad (3.)$$

where:

- $VM_n$  — fuel gas consumption by separated CHP unit, brought to standard<sup>10</sup> conditions (m<sup>3</sup>);
- $C_{1,2}$  — CH<sub>4</sub> concentration sensors (%);
- $V_1$  — amount of methane fed as ignition gas (m<sup>3</sup>);
- 0,7167 — methane density in normal conditions (kg/m<sup>3</sup>);
- 0,93 — standard conditions to normal conditions conversion ratio

Fed  $MM_{GAS}$  to be measured as following:

$$MM_{GAS} = V_2 \cdot C_2 \cdot 0,7167 \cdot 0,93, \quad (4.)$$

where:

- $V_2$  — amount of methane fed as fuel for vehicles, in standard conditions (m<sup>3</sup>);
- $C_2$  — CH<sub>4</sub> concentration sensor (%);
- 0,7167 — methane density in normal conditions (kg/m<sup>3</sup>);
- 0,93 — standard conditions to normal conditions conversion ratio.

Sensors represented in tables, shown after general description of methane consumption process.

### Crosschecking

Amount of methane used as fuel gas for CHP units undergoes crosschecking. This operation is performed by way of measurement of total amount of gas consumption (m<sup>3</sup>), that is defined by flow meter Gn5 (for data about flow meter see table below), which has structure as block of velocity, pressure and temperature sensors that measure amount of gas consumed by CHP units and data on methane concentration in point A1 with gas analyzer AO 2040 (ABB). Amount of methane to be calculated on the base of these data, but it is not used for database formation; it is used only for technological purposes and for crosschecking and control of CHP operation systems. This procedure is carried out on regular basis. Summary results of the internal cross checkings from 01.02.2010 until 31.07.2010 are presented in the table below

01.02.2010 — 31.07.2010				
month	Q Fuel Gas Consumption, m <sup>3</sup> /month	F Fuel Gas, Net Consumption, m <sup>3</sup> /month	Q Fuel Gas, Net Consumption, m <sup>3</sup> /month	Relative Difference in Readings Gn5*CH4/100 and $\sum$ BKT.M1- BKT.M4, %
	<b>Gn5</b>	<b>Gn5 * CH4/100</b>	<b><math>\sum</math> BKT.M1-BKT.M4</b>	
February 2010	11 260 009,99	3 628 295,68	3 629 111,88	- 0,02
March 2010	13 765 284,91	4 423 372,14	4 424 415,26	- 0,02
April 2010	14 840 254,03	4 591 923,70	4 592 901,10	- 0,02
May 2010	14 493 210,92	4 612 776,19	4 612 582,47	0,00
June 2010	15 356 915,33	4 770 852,54	4 769 064,93	0,04
July 2010	15 021 359,02	4 388 909,10	4 388 738,59	0,00
<b>Total</b>	<b>84 737 034,20</b>	<b>26 416 129,35</b>	<b>26 416 814,23</b>	<b>0,00</b>

Table 5. Summary results of cross checking

Measurement System	Manufacturer	Type	Serial Number	Allowable uncertainty	Calibration Date	Next Calibration Date
ADM	Keuter	Electronic	167	heat – 0,25% pressure – 0,5%	02.07.09 02.07.10	02.07.11

Table 6. Flow meter Gn5

<sup>10</sup> Standard conditions=293K and 760 mm Hg.



Scheme of location of main meters /sensors at Vostochnaya CHP in 2010

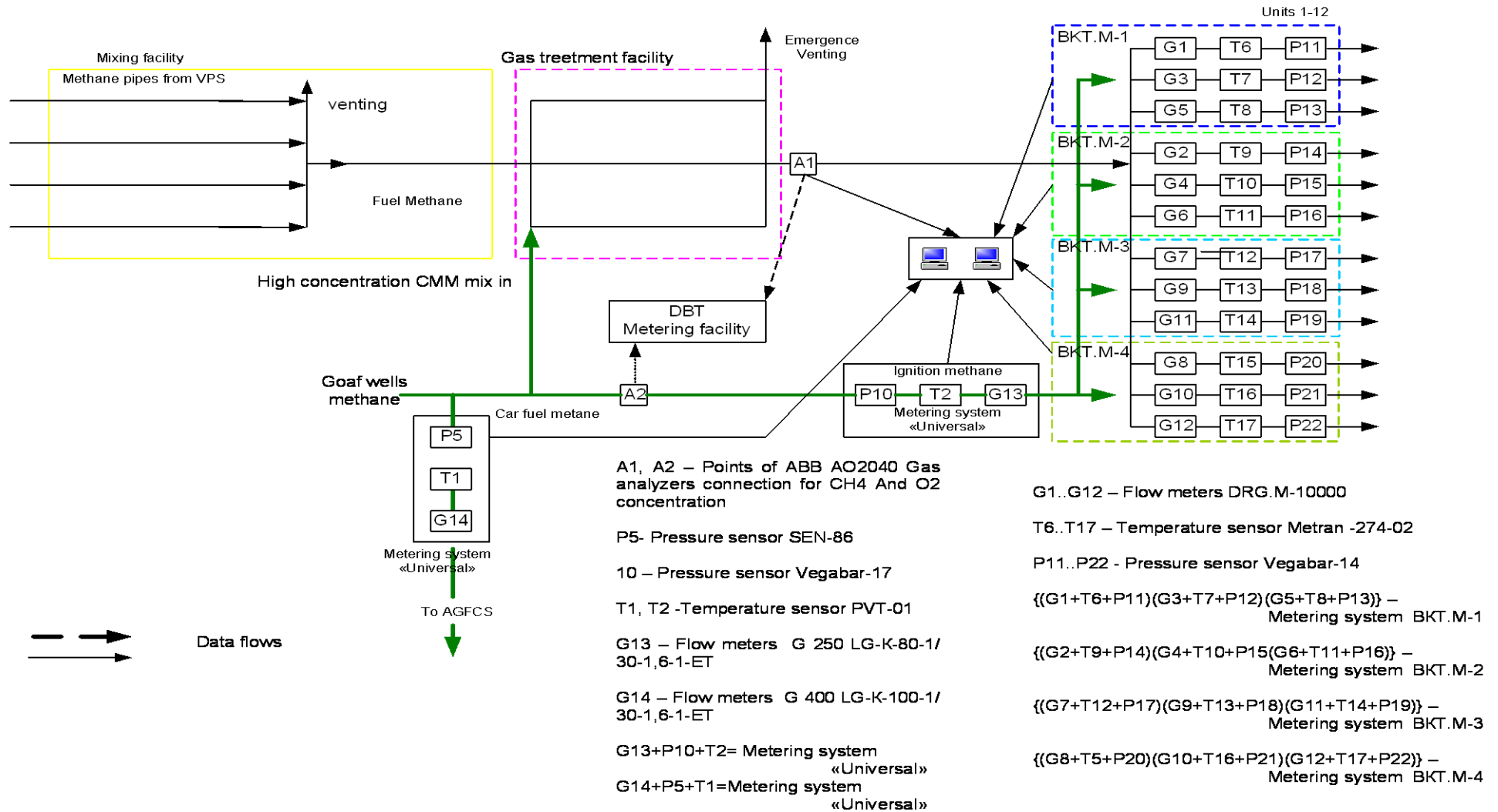

Figure 3 Scheme of location of primary meters/ sensors

General scheme of location of meters /sensors at Vostochnaya CHP in 2010

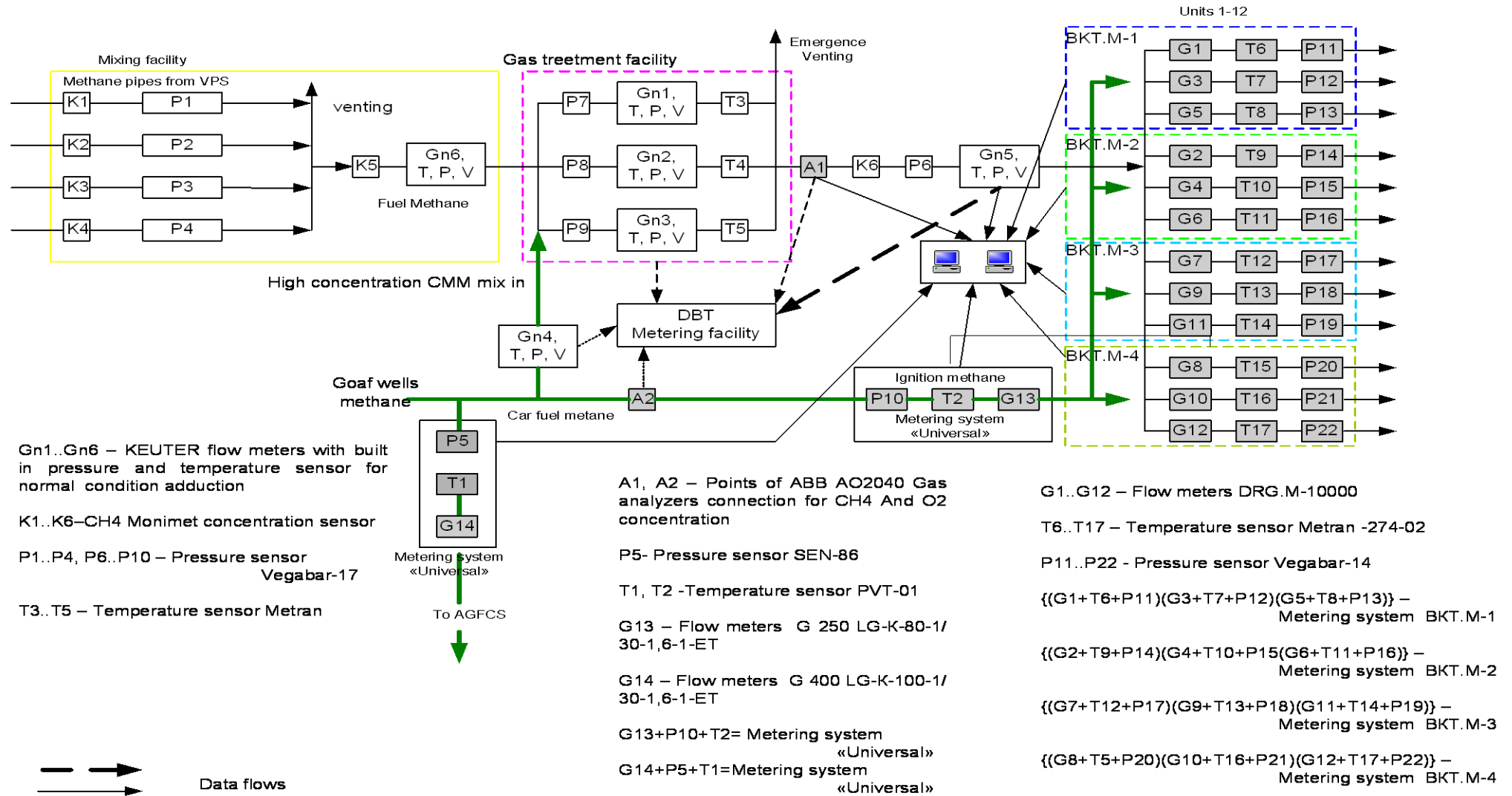

Figure 4. General scheme of location of meters/ sensors including secondary meters/sensors

The general flow of CMM and the metering can be described as follows.<sup>11</sup>

Coal mine gas of degassing and gas-suction is supplied through four lines from two Vacuum Pump Station (VPS) to gas mixing section of the CHP gas treatment facility. The concentration and pressure of methane are different in each pipe-line. These parameters are measured by K1...K4 (Monimet) concentration sensors and P1...P4 (Vegabar) pressure sensors. Measurements data of these sensors are not used in gas metering and have technological meaning; these data are channelled to automatic control system of the dispatch and used only for controlling purposes in order to obtain at the output homogeneous fuel methane with necessary concentration.

Concentration of methane that is fed to the gas treatment facility is measured by the sensor K5 (Monimet); temperature, pressure and flow are measured by flow meters Gn6 (Keuter), a unit of velocity, pressure, and temperature sensors. Surface well methane is mixed with fuel gas, if increase of its concentration is required. Admix (flow), temperature, and pressure of surface well methane is measured by flow meter Gn4 (Keuter) a unit of velocity, pressure, and temperature sensors. The concentration of admix methane from surface wells is measured by gas analyser AO 2040 (ABB) in A2 point (concentration of methane in admix and ignition gas are equal as these are included in common system of surface degasification- surface well gas methane). Having all this data the automatic control system of the dispatch can calculate amount of methane in the gas mixture.

At the gas treatment section of facility, methane is distributed between three lines where it is dried, cooled, cleaned and warmed. Acting flow measurements is provided by Gn1 - Gn3 (Keuter) flow meters together with velocity, pressure and temperature sensors. They transmit information to calculation equipment developed by DBT which is installed in separate premise. This unit calculates the values of actual consumption for normal conditions and channelled them to automatic control system of the dispatch computer system for operation and saving in database. For checking and reserve, pressure sensors P7 – P9 (Vegabar) and temperature sensors T3 – T5 (Metran) have been installed in pipe-lines.

At the outflow of gas treatment section the processing discharge valve is installed which levels out e pressure swings at abrupt changes of CHP operation regime. Pressure at the outflow of the section is controlled by processing sensor P6 (Vegabar).

With the purpose of fuel gas concentration definition, gas testing is made at the outflow of gas treatment section of facility in point A1 which is fed to gas analyzer AO 2040 (ABB) mounted at gas metering unit. Concentration measured is checked for the compliance with sensor K6 (Monimet). Flow meter Gn5 (Keuter) as a unit with velocity, pressure and temperature sensors, measures the gas amount used by CHP units. The methane amount is calculated based on the data of methane concentration but is not used for database establishment and metering, it is used only for technological purposes.

Further, fuel gas is supplied to the units of CHPs engine rooms. The flow meters G1- G12, type DPG.M-10000. temperature sensors T6 - T17 (Metran 274-02), and pressure sensors P11 - P22 (Vegabar -14) are mounted on the line of each 12 units. Their data are transmitted to micro- processing control system BKT.M designed for transformation of input information about gas parameters and for calculation of the base thereof of amount and volumetric amount of gas flow brought to standard conditions to calculate fuel gas amount which is used by each unit, and total amount in each engine room. Fuel gas amount is calculated based on the data of methane concentration in it. Fuel gas amount calculation is performed on the base of data received from control units for gas record BKT.M1-BKT.M4, and concentration of methane therein as received from gas analyzer AO 2040 (ABB) in point A1. Total amount of fuel gas is calculated by way of addition of figures of all gas record units BKT.M, and serves as a figure of CHP gas methane utilized. This information is entered into database and logs.

Ignition gas is supplied to CHP units from gas pipes of surface degasification wells. Total ignition gas consumption is metered by system Universal designed for transformation of input information about gas parameters and for calculation of the base thereof of amount and volumetric amount of gas flow brought to standard conditions, which included gas metering device G13 (G 250 LG-K-80-1/30-1,6-1-Ex), temperature sensor T2 (PVT-01-1), and pressure sensor P10 (Vegabar-17). Gas concentration is metered by gas analyzer AO 2040 (ABB) with gas test in the point A2. Based on data received from metering system Universal, ignition gas automatic control system is kept, which gas is supplied to CHP units and recorded in database and log.

<sup>11</sup> From 2008, DBT equipment is used as equipment for operation and control of stations, as well as for crosschecking. Main meters are installed at each CHP unit, and they transmit data to metering systems of the gas record units BKT.M. Gas record units BKT.M transmit data to computer. Each gas record unit BKT.M covers 3 CHP units. These systems are operated with fuel gas. Ignition gas for all CHP units is metered with a new metering system Universal. All this data are stored in place, and are transmitted to CHP computer system.

Gas that is supplied for motor vehicles filling is also supplied from gas pipes of surface degasification wells. Total motor vehicle filling gas consumption G14 is metered by system Universal designed for transformation of input information about gas parameters and for calculation of the base thereof of amount and volumetric amount of gas flow brought to standard conditions, which included gas metering device G14 (G 400 LG-K-100-1/30-1,6-1-Ex), temperature sensor T2 (PVT-01-1), and pressure sensor P5 (CEN-8601). As the gas for vehicle fuelling and ignition gas fed to CHP units are of one system of surface degasification, gas concentration control is performed by gas analyzer AO 2040 (ABB) with gas test in the point A2. Based on data thereof, amount of methane fed to AGFCP for motor vehicle filling, is recorded in database and log.

Methane volume which is supplied with fuel gas and methane of ignition gas gives total amount of methane supplied to CHPs.

Methane volume which is supplied with fuel gas and methane of ignition gas, methane for automobiles filling give total amount of methane consumed by Vostochnaya site of Zasyad’ko coal mine.



*Figure 5: Gas flow meter DRG.M-10000<sup>12</sup> temperature sensor Metran 274-02 and pressure sensor Vegabar-14 of metering system for gas record BKT.M at fuel gas pipeline of CHP unit.*

<sup>12</sup> DRG.M – 10000 — gas flow meter designed for transformation of volumetric flow of gas (at operational pressure) into numeric and impulsive signal.

## JI MONITORING REPORT

**Monitoring Report #8** "Utilization of Coal Mine Methane at the Coal Mine named after A.F. Zasyadko" page 21

In the table below the description of the meters/sensors of metering systems for gas record that are part of monitoring report drawing, are given:

### CHP gas metering equipment

Item No.	Metering instrument design	Work parameter	Manufacturer	Type	Serial number	Uncertainty level of data	Date of installation	Date of calibration	Date of next calibr.	Remarks
C1	Concentration of fuel gas	%	ABB	AO2040 Electronic	3.244705.5	±1%	2005	09.07.09 09.07.10	09.07.11	Connection A1
C2	Concentration of ignition gas	%	ABB	AO2040 Electronic	3.244704.5	±1%	2005	10.07.09 09.07.10	09.07.11	Connection A2

Calibration interval for gas analyzers is one year.

### Ignition gas record system Universal meters/sensors

Item No.	Gas to be measured	Metering instrument design	Work parameter	Manufacturer	Type	Serial number	Uncertainty level of data	Date of installation	Date of calibration	Date of next calibr.	Remarks
V1	Ignition	Ignition gas amount measurement	m <sup>3</sup>	NVP "GREMPIS" ltd	G 250 LGK-80-1/30-1,6-1-Ex	9771	±1% 60 to 400 m <sup>3</sup> /h	4 quarter 2007	10.03.09	10.03.11	Connection G13
		Ignition gas temperature measurement	°C	NVP "GREMPIS" ltd	PVT-01-1	6480	±0.5%	4 quarter 2007	10.03.09	10.03.11	Connection T2
		Ignition gas pressure measurement	bar	"VEGA" Germany	Vegabar-17	12307278	±0.5%	4 quarter 2007	10.03.09 09.03.10	09.03.11	Connection P10

Calibration interval for pressure sensor is one year.

Calibration interval for temperature sensor and gas meter is once in two years.

## JI MONITORING REPORT

Monitoring Report #8 “Utilization of Coal Mine Methane at the Coal Mine named after A.F. Zasyadko” page 22

*Motor vehicle filling gas metering system Universal meters/ sensors*

Item No.	Gas to be measured	Metering instrument design	Work parameter	Manufacturer	Type	Serial number	Uncertainty level of data	Date of installation	Date of calibration	Date of next calibr.	Remarks
V2	Gas for motor vehicle filling	gas for motor vehicle filling amount measurement	m <sup>3</sup>	NVP "GREMPIS" ltd	G 400 LGK-100-1/30-1,6-1-Ex	9786	±1% 97,5 to 650 m <sup>3</sup> /h	4 quarter 2007	15.07.09	15.07.11	Connection G14
		Gas for motor vehicle filling temperature measurement	°C	NVP"GREMPIS" " ltd	PVT-01-1	211	±0.5%	4 quarter 2007	28.07.09 28.07.10	28.07.12	Connection T1
		Gas for motor vehicle filling pressure measurement	bar	"COBOLD" Germany	SEN-86	45	±0.5%	4 quarter 2007	28.07.09 28.07.10	28.07.11	Connection P5

Calibration interval for pressure sensor is one year.

Calibration interval for temperature sensor and gas meter is once in two years.

## JI MONITORING REPORT

Monitoring Report #8 "Utilization of Coal Mine Methane at the Coal Mine named after A.F. Zasyadko" page 23

### Gas volume and volumetric consumption computing block

Item No.	Metering system	Work parameter: m <sup>3</sup> /h	manufacturer	Type	Serial number	Uncertainty level of data and accuracy	Date of installation	Data as of 01.02.2010 m <sup>3</sup>	Data as of 31.07.2010 m <sup>3</sup>	Difference	Date of calibration	Date of next calibration	Remarks
V <sub>1</sub>	Universal	Ignition gas amount	NVP"GREMPIS" ltd	Universal -2	6023	±0.2 %	4 quarter 2007	3 785 557,5	4 977 366,6	1 191 809,1	10.03.09	10.03.11	Main metering block
V <sub>2</sub>	Universal	Motor vehicle fuelling gas amount	NVP"GREMPIS" ltd	Universal -2	327	±0.2 %	4 quarter 2007	5 617 218	6 612 329	995 111	15.07.09 28.07.10	28.07.12	Main metering block

Calibration interval-once in two years.

### Gas volume and volumetric consumption computing blocks BKT.M -1 — BKT.M-4

Item No.	Metering system	Work parameter: m <sup>3</sup>	Manufacturer	Serial number	Uncertainty level of data and accuracy	Date of installation	Unit No.	Data as of 01.02.2010 m <sup>3</sup>	Data as of 31.07.2010 m <sup>3</sup>	Difference	Date of calibration	Date of next calibration	Remarks
V <sub>3</sub>	BKT.M-1	Fuel gas amount	Sibnefteavtomatika, Russia	245	• Pressure channels, not exceeding ±0.3 %; • Temperature channels, not exceeding ±0.5 %; • Consumption channels, not exceeding ±0.1 %; • Gas consumption definition status brought to standard conditions, not exceeding ±0.35 %; • Gas amount definition status brought to standard conditions, not exceeding ±0.35 %; • Change of running time, not exceeding ±0.1 %.	N/A	M1	27 919 390	35 886 688	7 967 298	21.08.07	21.08.10	Main metering block
							M3	27 511 388	35 313 772	7 802 384			
							M5	26 938 344	33 620 472	6 682 128			
V <sub>4</sub>	BKT.M-2	Fuel gas amount	Sibnefteavtomatika, Russia	095		N/A	M2	11 325 665	18 918 378	7 592 713	20.01.09	20.01.12	Main metering block
							M4	4 766 843	11 322 030	6 555 187			
							M6	10 404 930	19 148 778	8 743 848			
V <sub>5</sub>	BKT.M-3	Fuel gas amount	Sibnefteavtomatika, Russia	100		N/A	M7	17 001 216	24 420 716	7 419 500	18.03.08	18.03.11	Main metering block
							M9	24 120 722	31 952 380	7 831 658			
							M11	24 048 170	31 185 198	7 137 028			
V <sub>6</sub>	BKT.M-4	Fuel gas amount	Sibnefteavtomatika, Russia	099		N/A	M8	16 810 326	25 084 004	8 273 678	05.08.08	05.08.11	Main metering block
							M10	15 330 485	22 582 598	7 252 113			
							M12	4 339 246	12 220 796	7 881 550			

Calibration interval-once in three years.

## JI MONITORING REPORT

Monitoring Report #8 “Utilization of Coal Mine Methane at the Coal Mine named after A.F. Zasyadko” page 24

### Meters/ sensors of fuel gas metering system BKT.M – 1

Item No.	Gas to be metered	Symbol on scheme	Metering device designation	Work parameter	Manufacturer	Type	Serial number	Allowed uncertainty	Date of installation	Date of calibration	Date of next calibration	Remarks		
M1	Fuel	G1	Fuel gas amount measurement	m <sup>3</sup>	Sibnefteavtomatika, Russia	DRG.M-10000 Electronic	102	±1.0%	N/A	19.08.09	19.08.11	Fuel gas metering system BKT.M- 1		
		T6	Fuel gas temperature measurement	°C	Metran Industrial Group, Russia	Metran -274-02	510745	±0,5%	N/A	22.07.09 22.07.10	22.07.11			
		P11	Fuel gas pressure measurement	bar	"VEGA" Germany	Vegabar 14	14536534	±0,5%	N/A	04.06.09 04.06.10	04.06.11			
M3	Fuel	G3	Fuel gas amount measurement	m <sup>3</sup>	Sibnefteavtomatika, Russia	DRG.M-10000 Electronic	109	±1.0%	N/A	19.08.09	19.08.11		Fuel gas metering system BKT.M- 1	
		T7	Fuel gas temperature measurement	°C	Metran Industrial Group, Russia	Metran -274-02	510753	±0,5%	N/A	03.07.09 02.07.10	02.07.11			
		P12	Fuel gas pressure measurement	bar	"VEGA" Germany	Vegabar 14	14536342	±0,5%	N/A	04.06.09 04.06.10	04.06.11			
M5	Fuel	G5	Fuel gas amount measurement	m <sup>3</sup>	Sibnefteavtomatika, Russia	DRG.M-10000 Electronic	103	±1.0%	N/A	19.08.09	19.08.11			Fuel gas metering system BKT.M- 1
		T8	Fuel gas temperature measurement	°C	Metran Industrial Group, Russia	Metran -274-02	509669	±0,5%	N/A	22.07.09 22.07.10	22.07.11			
		P13	Fuel gas pressure measurement	bar	"VEGA" Germany	Vegabar 14	14447569	±0,5%	N/A	04.06.09 04.06.10	04.06.11			

Calibration interval of pressure and temperature sensor is one year.

Calibration interval of gas consumption sensors is once in two years.

(by calibration of DRG.M - 10000 at Ivano-Frankovskstandartmetrologia State-Owned Enterprise, calibration interval has been changed from 3 to 2 years ).



## JI MONITORING REPORT

Monitoring Report #8 “Utilization of Coal Mine Methane at the Coal Mine named after A.F. Zasyadko” page 25

### Meters/ sensors of fuel gas metering system BKT.M – 2

Item No.	Gas to be metered	Symbol on scheme	Metering device designation	Work parameter	Manufacturer	Type	Serial number	Allowed uncertainty	Date of installation	Date of calibration	Date of next calibration	Remarks
M2	Fuel	G2	Fuel gas amount measurement	m <sup>3</sup>	Sibnefteavtomatika, Russia	DRG.M-10000 Electronic	108	± 1.0%	N/A	15.06.09	15.06.11	Fuel gas metering system BKT.M - 2
		T9	Fuel gas temperature measurement	°C	Metran Industrial Group, Russia	Metran -274-02	510735	± 0.5%	N/A	21.07.09 21.07.10	21.07.11	
		P14	Fuel gas pressure measurement	bar	"VEGA" Germany	Vegabar 14	14568471	± 0.5%	N/A	02.06.09 02.06.10	02.06.11	
M4	Fuel	G4	Fuel gas amount measurement	m <sup>3</sup>	Sibnefteavtomatika, Russia	DRG.M-10000 Electronic	104	± 1.0%	N/A	15.06.09	15.06.11	
		T10	Fuel gas temperature measurement	°C	Metran Industrial Group, Russia	Metran -274-02	509670	± 0.5%	N/A	21.07.09 21.07.10	21.07.11	
		P15	Fuel gas pressure measurement	bar	"VEGA" Germany	Vegabar 14	14536186	± 0.5%	N/A	02.06.09 02.06.10	02.06.11	
M6	Fuel	G6	Fuel gas amount measurement	m <sup>3</sup>	Sibnefteavtomatika, Russia	DRG.M-10000 Electronic	097	± 1.0%	N/A	15.06.09	15.06.11	
		T11	Fuel gas temperature measurement	°C	Metran Industrial Group, Russia	Metran -274-02	510733	± 0.5%	N/A	21.07.09 21.07.10	21.07.11	
		P16	Fuel gas pressure measurement	bar	"VEGA" Germany	Vegabar 14	14536368	± 0.5%	N/A	02.06.09 02.06.10	02.06.11	

Calibration interval of pressure and temperature sensor is one year.  
 Calibration interval of gas consumption sensors is once in two years.

## JI MONITORING REPORT

Monitoring Report #8 “Utilization of Coal Mine Methane at the Coal Mine named after A.F. Zasyadko” page 26

*Meters/ sensors of fuel gas metering system BKT.M – 3*

Item No.	Gas to be metered	Symbol on scheme	Metering device designation	Work parameter	Manufacturer	Type	Serial number	Allowed uncertainty	Date of installation	Date of calibration	Date of next calibration	Remarks
<b>M7</b>	Fuel	G7	Fuel gas amount measurement	m <sup>3</sup>	Sibnefteavtomatika, Russia	DRG.M-10000 Electronic	098	± 1.0%	N/A	17.07.09	17.07.11	Fuel gas metering system BKT.M - 3
		T12	Fuel gas temperature measurement	°C	Metran Industrial Group, Russia	Metran -274-02	510744	± 0,5%	N/A	21.07.09 21.07.10	21.07.11	
		P17	Fuel gas pressure measurement	bar	"VEGA" Germany	Vegabar 14	14568573	± 0,5%	N/A	03.06.09 03.06.10	03.06.11	
<b>M9</b>	Fuel	G9	Fuel gas amount measurement	m <sup>3</sup>	Sibnefteavtomatika, Russia	DRG.M-10000 Electronic	099	± 1.0%	N/A	17.07.09	17.07.11	
		T13	Fuel gas temperature measurement	°C	Metran Industrial Group, Russia	Metran -274-02	510742	± 0,5%	N/A	21.07.09 21.07.10	21.07.11	
		P18	Fuel gas pressure measurement	bar	"VEGA" Germany	Vegabar 14	14536304	± 0,5%	N/A	03.06.09 03.06.10	03.06.11	
<b>M11</b>	Fuel	G11	Fuel gas amount measurement	m <sup>3</sup>	Sibnefteavtomatika, Russia	DRG.M-10000 Electronic	101	± 1.0%	N/A	17.07.09	17.07.11	
		T14	Fuel gas temperature measurement	°C	Metran Industrial Group, Russia	Metran -274-02	510738	± 0,5%	N/A	21.07.09 21.07.10	21.07.11	
		P19	Fuel gas pressure measurement	bar	"VEGA" Germany	Vegabar 14	14568610	± 0,5%	N/A	03.06.09 03.06.10	03.06.11	

Calibration interval of pressure and temperature sensor is one year.  
Calibration interval of gas consumption sensors is once in two years.

## JI MONITORING REPORT

Monitoring Report #8 “Utilization of Coal Mine Methane at the Coal Mine named after A.F. Zasyadko” page 27

### Meters/ sensors of fuel gas metering system BKT.M – 4

Item No.	Gas to be metered	Symbol on scheme	Metering device designation	Work parameter	Manufacturer	Type	Serial number	Allowed uncertainty	Date of installation	Date of calibration	Date of next calibration	Remarks		
M8	Fuel	G8	Fuel gas amount measurement	m <sup>3</sup>	Sibnefteavtomatika, Russia	DRG.M-10000 Electronic	105	± 1.0%	N/A	01.07.09	01.07.11	Fuel gas metering system BKT.M - 4		
		T15	Fuel gas temperature measurement	°C	Metran Industrial Group, Russia	Metran -274-02	510754	± 0,5%	N/A	24.07.09 23.07.10	23.07.11			
		P120	Fuel gas pressure measurement	bar	"VEGA" Germany	Vegabar 14	14568589	± 0,5%	N/A	05.06.09 04.06.10	04.06.11			
M10	Fuel	G10	Fuel gas amount measurement	m <sup>3</sup>	Sibnefteavtomatika, Russia	DRG.M-10000 Electronic	096	± 1.0%	N/A	01.07.09	01.07.11		Fuel gas metering system BKT.M - 4	
		T16	Fuel gas temperature measurement	°C	Metran Industrial Group, Russia	Metran -274-02	510755	± 0,5%	N/A	24.07.09 23.07.10	23.07.11			
		P21	Fuel gas pressure measurement	bar	"VEGA" Germany	Vegabar 14	14536306	± 0,5%	N/A	05.06.09 04.06.10	04.06.11			
M12	Fuel	G12	Fuel gas amount measurement	m <sup>3</sup>	Sibnefteavtomatika, Russia	DRG.M-10000 Electronic	100	± 1.0%	N/A	01.07.09	01.07.11			Fuel gas metering system BKT.M - 4
		T17	Fuel gas temperature measurement	°C	Metran Industrial Group, Russia	Metran -274-02	510747	± 0,5%	N/A	24.07.09 23.07.10	23.07.11			
		P22	Fuel gas pressure measurement	bar	"VEGA" Germany	Vegabar 14	14568606	± 0,5%	N/A	05.06.09 04.06.10	04.06.11			

Calibration interval of pressure and temperature sensor is one year.  
 Calibration interval of gas consumption sensors is once in two years.

The monitoring system for the emission reductions achieved in the course of the project implementation has been integrated in the Zasyadko Coal Mine existing controlling and reporting system. That allows for obtaining reliable and easy verifiable data related to the project performance, ensuring thus the quality and efficiency of the monitoring system.

All source information on performance parameters and calculations have been obtained directly on site and after that reported to the Coal Mine dispatching office. The work parameters of CMM flows as well as heat and power generated will be crosschecked to provide quality and reliability of monitored data. To ensure reliable and non-stop performance of cogeneration plant the inputs of natural gas from the natural gas pipeline are envisaged.

**CMM consumption of gas filling stations**

Each gas filling station keeps records in the register. Calculations of methane fuelled are executed according to data pressure difference of manometers. Concentration of methane is measured monthly with ABB AO 2040 at CHP and surface well gas analysis. Besides, the concentration of methane is measured locally with an interferometer. Temperature and pressure meters are installed too. The volume of methane is measured by “Universal-2” metering system.

**B.1.3. Calibration procedures**

For Electricity Meters:

QA/QC (Quality Assurance/ Quality Control) procedures	Body responsible for calibration and certification
Calibration interval of such meters is six years. Calibration procedures for meters are implemented in compliance with calibration methodology developed for “Elster-Metronika” meters, Russia. Manufacturer’s warranty-36 months	Manufacturer “Elster-Metronika” LLC, Russia

For Heat Meters

QA/QC (Quality Assurance/ Quality Control) procedures	Body responsible for calibration and certification
Calibration interval of such meters is two years. Calibration procedures for meters are implemented in compliance with calibration methodology developed for ASWEGA meters, Russia. Manufacturer’s warranty-18 months	Donetsk Centre for Standardization and Metrology

For CMM meters:

QA/QC (Quality Assurance/ Quality Control) procedures	Body responsible for calibration and certification
Keuter ADM1 Electronic. Calibration interval of such meters is 1 year <sup>13</sup>	Donetsk Centre for Standardization and Metrology
Gas Analyzer ABB A02040. Calibration interval of such meters is 1 year <sup>13</sup> .	Donetsk Centre for Standardization and Metrology

**B.1.4. Involvement of Third Parties:**

- Donetsk Centre for Standardization and Metrology<sup>14</sup>
- Ivano-Frankovsk for Standardization and Metrology

**B.2. Date collection (accumulated data for the whole monitoring period):**

For the operational and management structure of the project see PDD, Figure 9: *Monitoring and quality control system for Vostochnaya and Yakovlevskaya sites*

<sup>13</sup> As there is no state regulation for such kind of equipment there was a decision of Ukrainian Centre for Standardization and Metrology for one year calibration period.

<sup>14</sup> All metering equipment shall be calibrated subject to provisions and methods as defined by regulations of this centre.

**B.2.1. List of fixed default values:**

ID number	Date variable	Source of data	Date unit	Comment
P6 CEFC <sub>CH4</sub>	Carbon emission factor for combusted methane	2006 IPCC Guidelines for National Greenhouse Gas Inventories. Volume 2: Energy Chapter 4: Fugitive Emissions	tCO <sub>2</sub> e/tCH <sub>4</sub>	Set at 2.75 tCO <sub>2</sub> e /tCH <sub>4</sub> See also table CMM meters
P12 Eff <sub>CHP</sub>	Efficiency of methane destruction/oxidation in CHP	2006 IPCC Guidelines for National Greenhouse Gas Inventories. Volume 2: Energy Chapter 4: Fugitive Emissions	%	Set at 99.5%
P14 Eff <sub>GAS</sub>	Overall efficiency of methane destruction/oxidation at the vehicles	2006 IPCC Guidelines for National Greenhouse Gas Inventories. Volume 2: Energy Chapter 4: Fugitive Emissions	%	Set at 98.5%
P15 GWP <sub>CH4</sub>	Global warming potential of methane	2006 IPCC Guidelines for National Greenhouse Gas Inventories. Volume 2: Energy Chapter 4: Fugitive Emissions	tCO <sub>2</sub> e/tCH <sub>4</sub>	Set at 21

Table 7: Project Default Values

ID number	Date variable	Source of data	Date unit	Comment
B13 F <sub>grid,generated,y</sub>	Emissions factor of electricity of replaced grid electricity production by the project activity in year	See Annex 2 PDD	tCO <sub>2</sub> /MWh	Set at 0,807
B14 EF <sub>grid,reduced,y</sub>	Emissions factor of electricity of replaced on-site electricity consumption by the project activity	See Annex 2 PDD	tCO <sub>2</sub> /MWh	Set at 0,896
B20 EF <sub>heat,vost</sub>	Emissions factor for heat at Vostochnaya site in the baseline scenario	See Annex 2 PDD	tCO <sub>2</sub> /GJ	Boiler efficiency 90% Set at 0,063
B22 EF <sub>heat,yak</sub>	Emissions factor for heat at Yakovlevskaya site in the baseline scenario	See Annex 2 PDD	tCO <sub>2</sub> /GJ	Boiler efficiency 90% Set at 0,063
B24 EF <sub>heat,centr</sub>	Emissions factor for heat at Centralnaya site in the baseline scenario	See Annex 2 PDD	tCO <sub>2</sub> /GJ	Boiler efficiency 90% Set at 0,143
B25 VFUEL <sub>y</sub>	Vehicle fuel provided by the project activity	Fuel Meters	GJ	This value will be calculated based MM <sub>GAS</sub> of the project scenario multiplied with LHV of methane
B26 EF <sub>v</sub>	Emissions factor for vehicle operation replaced by the project activity	2006 IPCC	tCO <sub>2</sub> /GJ	See annex 2 PDD Set at 0,072

Table 8: Baseline Default Values

**B.2.2. List of variables:**

Project emissions variables to be measured:

- *MM<sub>CHP</sub>* — Methane measured sent to power plant (tCH<sub>4</sub>);
- *MM<sub>GAS</sub>* — Methane measured supplied to gas grid for vehicle use (tCH<sub>4</sub>).

Baseline emissions variables to be measured:

- *GEN<sub>CHP</sub>* — Net electricity generated by the project activity by the CHP plants;
- *EL<sub>consumed</sub>* — Net electricity consumed by the mine on-site;
- *HEAT<sub>consumed, vost, y</sub>* — Heat consumed at Vostochnaya site delivered by the project year y

**B.2.3. Date concerning GHG emissions by sources of the project activity (referring to paragraph 53(a)):**

Year	MM <sub>GAS</sub> (tCH <sub>4</sub> )
01.02.2010 – 31.07.2010	663

*Table 9: Data to be collected in the project scenario*

Year	MM <sub>CHP</sub> (tCH <sub>4</sub> )
01.02.2010 – 31.07.2010	19 727

*Table 10: Data to be collected in the project scenario*

For Methane analysis data refer please to Annex 1 document.

**B.2.4. Date concerning GHG emissions by sources of the baseline (referring to paragraph 53(b)):**

Year	GEN <sub>CHP</sub> (MWh)	El <sub>Cons</sub> (MWh)	HEAT <sub>cons, vost, v</sub> (GJ)
01.02.2010 – 31.07.2010	91 927,209	104 129,241	97 225

*Table 11: Data collected in the baseline scenario*

**B.2.5. Date concerning leakage (referring to paragraph 53(c)):**

Not Applicable.

**B.2.6. Date concerning environmental impacts (referring to paragraph 53(d)):**

All activity under the project is performed subject to Ukrainian current environmental law. At construction of CHP and AGFCP, Environmental Impact Assessment has been performed. Pursuant to Atmospheric Air Protection Law of Ukraine, as approved by Ukrainian Board of Ministers on March 13, 2002 # 302 and Order of Ukrainian Ministry of Environmental Protection dd. 09.03.2006 # 108. Mine obtains allowances for emission of contaminating substances. Pollutant emissions inventory conducted with the assistance of third-party certified company that provides screening and analysis of samples contaminants pollutant substance with own attorney equipment.

Reporting an monitoring of emissions is performed constantly; all statistical reports are prepared and submitted pursuant to Guide to Filling In the State Statistical Control Statements for Atmospheric Air N # - TP (air) (annual) and # 2- TP (air) (quarterly) Atmospheric Air Protection Report issued by Derzhkomstat (State Committee of Statistics) # 674 dd. 30.12.2004.

The impact of the project to the condition of waters is insignificant due tot use of water for domestic needs only. At CHP, Grid Water Consumption Metering Device Reading Log is kept; data therefrom are used for preparation of statistical reports. Environmental Impact monitoring for water condition is performed and all statistic report statements are submitted pursuant to the current law of Ukraine.

During project implementation, measures are established that relate to domestic activity only (service and repair of equipment), and household activity. Monitoring of waste is performed, and statistical report statements are submitted: # N 1-VT "Waste and Package and Tare Accounting pursuant to the current law of Ukraine.

**B.3. Date processing and archiving (incl. software used):**

All dispatchers are responsible for data management. Besidesm dispatchers prepare standard daily, weekly, monthly, and annual reports. All appropriate data are collected daily, and archived both in electronic and paer form (see calculation CO<sub>2</sub>) All data will be saved in electronic data carriers and in paper form at least two years after implementation of this project will be completed.

Commissioning of modern computer control system will provide efficient online monitoring and performance efficiency analysis. Data from all controlling equipment are automatically transferred to database with the aid f appropriate software. Immediate notification abut any significant of the data being monitored from the operation parameter is performed including determination of the source of such deviation. This makes dispatcher abe to perform efficient management with making corrections by his subordinates in the shift including technical staff on-duty, and eliminate such deviations.

## JI MONITORING REPORT

---

**Monitoring Report #8** “Utilization of Coal Mine Methane at the Coal Mine named after A.F. Zasyadko” page 31

Information from database is transferred monthly (first days of the month) to hard data carriers and is stored at two servers. Daily logs for fuel gas consumption are kept for each unit G 1-G12, ignition gas G13 and gas consumed from surface degasification- AGFCP G14.

Person in charge for data saving appointed: Valeriy Cherednikov; list of persons having access to data storage facilities is formed. Archive of the documents which are kept in paper form, is stored out of AGFCP. Passwords for servers are monthly changed; for each server, persons in charge are appointed, and list of the persons having access is formed.

For record - keeping of GHG emission reduction, own software has been developed by CHP Automatic Control System and Processing Service which provides record -keeping for fuel gas and heat.

Following software has been purchased either:

-Checker 8 (integrated software developed and written by the manufacturer; to be supplied with the Universal control unit) – ignition gas and AGFCP gas record -keeping;

- Alfa- Center measuring and computing complex integrated into ASKUE (common mine automatic system of power commercial record -keeping) - power record -keeping;

-DIA.NE.XT (software delivered with CHP units)– control, regulation, indication, setting, and saving of data for CHP unit.

### **B.4. Special event log:**

During this monitoring period, no special events occurred.

**SECTION C. Quality assurance and quality control measures:**

**C.1. Documented procedures and management plan:**

**C.1.1. Roles and responsibilities:**

The general project management is implemented by the Deputy General Director of the Zasyadko Coal Mine through supervising and coordinating activities of his subordinates, such as deputy director on surface degasification, chief power engineer, chief heating engineer, and heads of safety engineering departments. On-site day-to-day management is implemented by the manager of cogeneration station who directs two shift operators responsible for cogeneration modules and gas treatment plant performance. An on-duty electrician works at the plant. During the daytime a group of mechanics who are responsible for preventive measures and maintenance of all technological equipment, metering instruments as well as of automation tools and telemechanics are present on-site. On-line information transmitted directly to the head of the shift into the Coal Mine Central Dispatching Office. The cogeneration plant is in 24 hours operation. Three shifts by eight hours have been introduced.

At the main objects the responsibilities are as follows:

- VPS operator controls data before VPS and after VPS (at the gas treatment plant) including CMM and natural gas flow parameters;
- Two CHP dispatchers control data on CHP unit inputs (gas treatment plant), operational process parameters, and heat and power output; they perform daily keeping of logs for consumption of fuel, ignition, and surface degasification well gas consumed by AGFCP.
- Two cogeneration plant operators control data at the inlets of cogeneration modules (at the gas treatment plant), work process parameters, and heat and power output. Substation operator controls data on electric power amounts dispatched to and supplied from the grid as well as in-house electricity consumption.

All information is transferred to CHP dispatching office, and is controlled in online mode by shift foreman. Based on information provided by dispatching office, monitoring engineer prepares monthly and annual reports about monitoring of power, gas, heat and emissions, and provides them to CHP Technical Director and Lease Enterprise Mine named after A.F. Zasyadko General Director Deputy. General supervision over monitoring system is carried out by management of Zasyadko Coal Mine according to control and reporting system in place.

Monitoring Dataflow Chart is shown below.

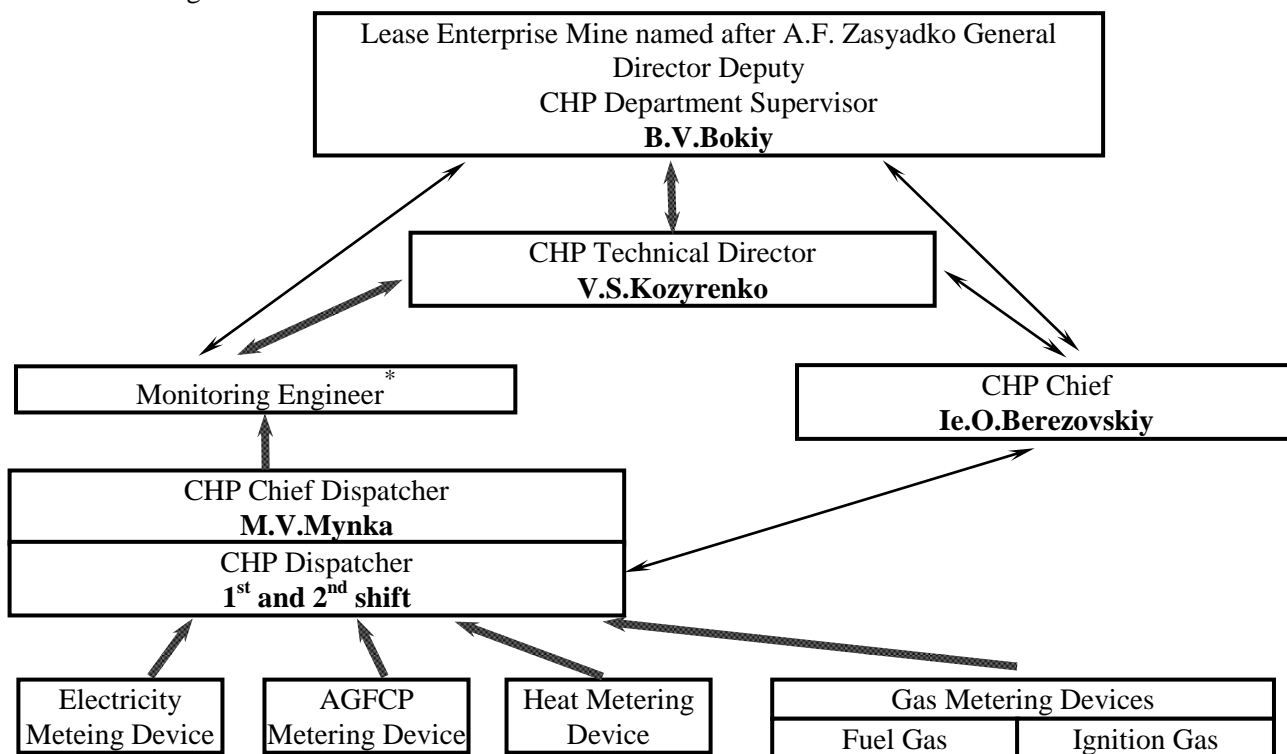

\* For 2010, this duty is performed by **V.V. Cherednikov**, Gas Treatment Lead Engineer.

Figure 6: Monitoring Dataflow Chart



**C.1.2. Trainings:**

GE Jenbacher (Austria) has delivered CHP main equipment being CHP units. As specified in the contract, training of staff that operates these units was performed in Austria. GE Jenbacher technicians have performed extra training during installation and commissioning works. Employees in charge for monitoring control have also passed training during installation of the said system.

Extra training is performed during equipment operation. CHP and VPS staff training program, as well as emergency training, are submitted as separate document represented as EMISSION MONITORING MANUAL FOR Mine named after A.F.Zasyadko (Manual 2), which also includes structural diagram of technical maintenance provision and state calibration of meters of automated metering system.

CHP Chief Dispatcher is responsible for training program development. Training programs required approval of Lease Enterprise Mine named after A.F.Zasyadko Director General.

Safety measure training is performed once every three months; all employees pass an exam in safety measures once a year. CHP staff and visitors are provided with individual protection devices for protection from harmful factors of activity.

**C.2. Involvement of Third Parties:**

The Donetsk Centre for Standardization and Metrology and Ivano-Frankovsk Centre for Standardization and Metrology are Third Parties involved.

**C.3. Internal audits and control measures:**

Introduction of a modern computerized control system allows for efficient on-line monitoring and reviewing work process performance at the Zasyadko Central Dispatching office every fifteen minutes. (Especially for fuel and ignition gas consumption, their parameters and electricity and heat generated data can be obtained every 10 seconds if requested). Any considerable deviation of monitored data from given work parameters will be promptly noticed and source of such deviation will be easily identified. In turn this enables the head of shift to efficiently coordinate adjustment actions of his shift subordinates including on-duty technical staff that will improve work process and eliminate such deviations. This system improved operational process and eliminated lacks in control of CHP gas consumption.

**C.4. Troubleshooting procedures<sup>15</sup>**

See C .1.2

In case of a break down of CMM supply system (either of whole system or separate feeding pipe) methane-air mixture will be urgently released into the atmosphere through the emergency gas vent stack. The shut-off valves will automatically close CMM supply pipes, natural gas will be fed into gas treatment plant and consequently into the inlets of engines and into pre-chambers. As the main gas record blocks (figure 3) are after the venting stack, only combusted CMM will be accounted for.

---

<sup>15</sup> At CHP, the equipment of the same type is installed, for substitution of main equipment for short period in case of breakdown or calibration- electricity and heat meters, CMM metering equipment, pressure, temperature sensors, etc. These devices, being connected to or installed, are able to transfer all data to monitoring and control computer system. Equipment is also calibrated in certain period by Centre for Standardization and Metrology, and Ivano-Frankovsk Centre for Standardization and Metrology.

**SECTION D. Calculation of GHG emission reductions**

**D.1. Project emissions**

The project emissions of the project are given by the following equation. The emissions for the use to capture and use methane  $PE_{ME}$  have not been taken as the energy use for the vacuum pumps are outside the project boundary (see section B.3 of PDD) and the annual electricity consumption of the gas filling station results in emission below 2,000 tCO<sub>2</sub>e.

$$PE_y = PE_{MD} + PE_{UM}, \quad (5.)$$

where:

- $PE_y$  - project emission in year y (tCO<sub>2</sub>e)
- $PE_{MD}$  - project emissions from methane destroyed (tCO<sub>2</sub>e);
- $PE_{UM}$  - project emissions from un-combusted methane (tCO<sub>2</sub>e)

**The project emissions from methane destroyed**

The project emissions from methane destroyed are given by the equation below. Methane will be destroyed in CHPs and as the CHP produces both electricity and heat at one source,  $MD_{ELEC}$  and  $MD_{HEAT}$  are combined into  $MD_{CHP}$ . No flaring takes place so  $MD_{FL} = 0$ .

$$PE_{MD} = (MD_{CHP} + MD_{GAS}) \times (CEF_{CH4} + r \times CEF_{NMHC}), \quad (6.)$$

At  $r = PC_{NMHC} / PC_{CH4}$

where:

- $PE_{MD}$  - project emissions from CMM destroyed (tCO<sub>2</sub>e);
- $MD_{CHP}$  - methane destroyed in the CHPs (tCH<sub>4</sub>);
- $MD_{GAS}$  - methane destroyed by the vehicles supplied by the new gas filling stations (tCH<sub>4</sub>);
- $CEF_{CH4}$  - carbon emission factor for combusted methane (2.75 tCO<sub>2</sub>e/tCH<sub>4</sub>).
- $CEF_{NMHC}$  - carbon emission factor for combusted non-methane hydrocarbons (the concentration varies, and, therefore, to be obtained through periodical analysis of captured methane) (tCO<sub>2</sub>e/tNMHC)<sup>16</sup>;
- $r$  - relative proportion of NMHC compared with methane;
- $PC_{CH4}$  - concentration (in mass) of methane in extracted gas (%);
- $PC_{NMHC}$  - concentration (in mass) of NMHC in extracted gas (%).

The relative proportion of NMHC was monitored, and their concentration is less than 1%. Therefore, NMHC were excluded from calculation. So:

$$PE_{MD} = (MD_{CHP} + MD_{GAS}) \times CEF_{CH4}, \quad (7.)$$

**Emissions of CHPs**

The emissions of CHPs are given by following equations:

$$MD_{CHP} = MM_{CHP} \times Eff_{CHP}, \quad (8.)$$

where :

- $MD_{CHP}$  - methane destroyed at heat and power generation (tCH<sub>4</sub>);
- $MM_{CHP}$  - measured methane sent to CHP (tCH<sub>4</sub>);
- $Eff_{CHP}$  - efficiency of methane destruction/ oxidation at CHP (taken as 99.5% of IPCC).

<sup>16</sup> At the moment non-methane hydrocarbons are not included in calculation because of concentration less than 1%. Their concentration is checked quarterly with laboratory analyses. In case of concentration more than 1% it will be considered in calculations.

**D.2. Emissions of gas utilization**

Some methane will be supplied to the gas filling stations that will supply the vehicles. The emissions as a result are given by the following equations.

$$MD_{GAS} = MM_{GAS} \times Eff_{GAS}, \quad (9.)$$

where:

- $MD_{GAS}$  - methane destroyed by the vehicles supplied by the gas filling stations (tCH<sub>4</sub>);
- $MM_{GAS}$  - methane measured supplied to vehicles supplied by the gas filling stations (tCH<sub>4</sub>);
- $Eff_{GAS}$  - overall efficiency of methane destruction/ oxidation through gas grid to various combustion end uses, combining fugitive emissions from the gas grid and combustion efficiency at end user (taken as 98.5% or IPCC).

**Emissions from un-combusted methane.**

$$PE_{UM} = GWP_{CH_4} \times (MM_{CHP} \times (1 - Eff_{CHP}) + MM_{GAS} \times (1 - Eff_{GAS})), \quad (10.)$$

where:

- $PE_{UM}$  - project emissions from un-combusted methane (tCO<sub>2</sub>e);
- $GWP_{CH_4}$  - global warming potential of methane (21 tCO<sub>2</sub>e/tCH<sub>4</sub>);
- $MM_{CHP}$  - methane measured sent to use at CHP (tCH<sub>4</sub>);
- $Eff_{CHP}$  - efficiency of methane destruction in CHP (taken as 99.5% or IPCC);
- $MM_{GAS}$  - methane measured sent to use for gas filling (tCH<sub>4</sub>);
- $Eff_{GAS}$  - efficiency of methane destruction in vehicle usage (taken as 98.5% or IPCC).

**D.3.1. Project emissions:**

Year	[tCO <sub>2</sub> e/year]	
Total: 01.02.2010 – 31.07.2010	[tCO <sub>2</sub> e]	58 056

Table 12: project emissions

**D.3.2. Baseline emissions:**

The baseline emissions are given by following equation. There is no destruction of methane in baseline scenario at the mine,  $BE_{MD,y} = 0$

$$BE_y = BE_{MR,y} + BE_{Use,y}, \quad (11.)$$

where:

- $BE_y$  - baseline emissions in year y (tCO<sub>2</sub>e);
- $BE_{MR,y}$  - baseline emissions from release of methane into the atmosphere that are avoided by the project activity in year y (tCO<sub>2</sub>e);
- $BE_{Use,y}$  - baseline emissions from the production of power, heat replaced by the project activity in year y (tCO<sub>2</sub>e).

**Baseline emissions of methane avoided by the project activity.**

As there is neither CBM (coal bed methane) nor CMM (coal mine methane) at the mine, the emissions equal the amount of post-mining CMM captured in the project activity that is sent to CHP and the gas filling stations.

$$BE_{MR,y} = GWP_{CH_4} \times (CMM_{PJ,CHP,y} + CMM_{PJ,GAS,y}), \quad (12.)$$

where :

- $CMM_{PJ,CHP,y}$  - post-mining CMM captured, sent to and destroyed in the CHP in the project activity in year y (tCH<sub>4</sub>);

- $CMM_{PJ,GAS,y}$  - pre-mining CMM captured, supplied to the net gas filling stations and destroyed by the vehicles in the project activity in year y (tCH<sub>4</sub>);
- $GWP_{CH_4}$  - global warming potential for methane (=21 tCO<sub>2</sub>e/tCH<sub>4</sub>).

**Baseline emissions of replacement of electricity, heat and vehicle fuel by the project activity**

As there is only post-mining CMM involved the baseline emissions are given in the following equation:

$$B_{Use,y} = BE_{Use,el,y} + BE_{Use,heat,y} + BE_{Use,gas} , \quad (13.)$$

where:

- $BE_{Use,y}$  - potential total baseline emissions from the production of power, heat, and vehicle fuels replaced by the project activity in year y (tCO<sub>2</sub>);
- $BE_{Use,el,y}$  - total baseline emissions from the production of power, replaced by the project activity in year y (tCO<sub>2</sub>);
- $BE_{Use,heat,y}$  - total baseline emissions from the production of heat, replaced by the project activity in year y (tCO<sub>2</sub>);
- $BE_{Use,gas}$  - total baseline emissions of vehicle fuels, replaced by the project activity in year y (tCO<sub>2</sub>e).

**Baseline emissions of replacement of electricity (power)**

Baseline emissions of replacement of electricity by the project activity are given by two equations. When the amount of electricity generated in a year by the project activity is less than the total amount of electricity consumed by mine, the baseline emissions are as follows:

$$BE_{Use,el,y} = GEN_{CHP,y} \times EF_{grid,reduced} , \quad (14.)$$

When the amount of electricity generated in year by the project activity is more than total amount of electricity consumed by mine (i.e. electricity will be supplied to the grid), the baseline emissions are as follows:

$$BE_{Use,el,y} = (GEN_{CHP,y} - EL_{cons,y}) \times EF_{grid,produced,y} + EL_{CONS,y} \times EF_{grid,reduced,y} , \quad (15.)$$

where:

- $BE_{Use,el,y}$  - total baseline emissions from the production of power, replaced by the project activity in year y (tCO<sub>2</sub>);
- $GEN_{CHP,y}$  - net electricity generated by the project activity of the CHP plants (MWh);
- $EF_{grid,produced,y}$  - emission factor of electricity of replaced grid electricity production by the project activity in year y (tCO<sub>2</sub>/MWh);
- $EL_{CONS,y}$  - net electricity consumed by mine on-site in year y (MWh);
- $EF_{grid,reduced,\delta}$  - emissions factor for electricity of replaced on-site electricity consumption by the project activity (tCO<sub>2</sub>/MWh)

For this monitoring period, the net electricity generated is less than net electricity consumed (see section B.1.2). Therefore, formula 14 was used.

**Baseline emissions of replacement of heat**

Heat produced by CHP supplies Vostochnaya site. Baseline emissions are given by following equation.

$$BE_{Use,Heat,y} = HEAT_{cons,vost,y} \times EF_{Heat,vost} \quad (16.)$$

where:

- $HEAT_{cons,vost,y}$  - heat consumed at Vostochnaya site, supplied by the project activity in year y (GJ);
- $EF_{Heat,vost}$  - emission factor for heat at Vostochnaya site in the baseline scenario (tCO<sub>2</sub>/GJ).

**Baseline emissions of replacement of vehicle fuels**

The baseline emissions of the replacement of vehicle fuels by the project activity are given by the following equation.

$$BE_{Use.Gas} = VFUEL_y \cdot xEF_v \tag{17.}$$

where:

- $VFUEL_y$  - vehicle fuel provided by the project activity (GJ);
- $EF_v$  - emission factor for vehicle operation replaced by the project activity (tCO<sub>2</sub>/GJ).

**Emission factor for vehicle fuels**

Emission factor for vehicle fuels is given by following equation.

$$EF_v = \frac{EF_{cos\lambda}}{Eff_v} \times \frac{44}{12} \times \frac{1TJ}{1000GJ} \tag{18.}$$

where:

- $EF_v$  - emission factor for vehicle fuels replaced by the project activity (tCO<sub>2</sub>/GJ);
- $EF_{cos\lambda}$  - emission factors for CO<sub>2</sub> four fuels used for vehicle operation replaced by the project activity (tCO<sub>2</sub>/GJ);
- $Eff_v$  - efficiency of vehicle motors (%);
- $44/12$  - carbon to Carbon Dioxide conversion factor;
- $1/1000$  - TJ to GJ conversion factor.

Year	[tCO <sub>2</sub> e/year]	
Total: 01.02.2010 – 31.07.2010	[tCO <sub>2</sub> e]	519 083

Table 13: Baseline emissions

**D.3.3. Leakages:**

Not Applicable

**D.3.4. Emission reduction summary in monitoring period:**

Year	[tCO <sub>2</sub> e/year]	
Total: 01.02.2010 – 31.07.2010	[tCO <sub>2</sub> e]	461 027

Table 14: Emission reductions

**JI MONITORING REPORT**

Gas sample analysis – 1<sup>st</sup> quarter 2010<sup>17</sup>

**APPROVED**

P.S.Pashkovskiy  
First Director Deputy, Science  
Activity, Dr. Sc. < signature >  
Seal  
The 10<sup>h</sup> of February, 2010

**Percentage of matters in samples of gas taken on 08.02.10  
at Lease Enterprise Mine named after A.F.Zasyadko**

Main Components	Sampling Point		
	Vacuum Pump Station-1		Vacuum Pump Station -2
	First group	Second group	Second group
	Concentration, %		Concentration, %
Methane CH <sub>4</sub>	18,7	18,7	40,2
Ethan C <sub>2</sub> H <sub>6</sub>	0,04	0,04	0,6
Propane C <sub>3</sub> H <sub>8</sub>	0,0018	0,0018	0,04
Butane C <sub>4</sub> H <sub>10</sub>	0,0062	0,0062	0,007
Pentane C <sub>5</sub> H <sub>12</sub>	n/a	n/a	n/a
Hexane C <sub>6</sub> H <sub>14</sub>	n/a	n/a	n/a
Carbon Oxide CO	n/a	n/a	0,0006
Hydrogen H <sub>2</sub>	n/a	n/a	0,05
Carbon Dioxide CO <sub>2</sub>	0,05	0,05	0,06
Nitrogen N <sub>2</sub>	65,8	65,8	47,4
Oxygen O <sub>2</sub>	12,8	12,8	11,1
Argon Ar	0,72	0,72	0,42
<b>Micro-Components</b>	<b>mg/Nm<sup>3</sup></b>		
Ammonia NH <sub>3</sub>	0,004	0,004	n/a
Chlorine Cl <sub>2</sub>	n/a	n/a	n/a
Fluorine F <sub>2</sub>	n/a	n/a	n/a
hydrogen sulphide H <sub>2</sub> S	0,007	0,007	n/a
Sulfide dioxide SO <sub>2</sub>	n/a	n/a	n/a
Dust, mg/m <sup>3</sup>	<1	<1	<1
Moisture, mg/m <sup>3</sup>	2980	2980	2630

VPS 1 includes first and second set combined in common degasification line.

\* re-calculated per dry gas

Analysis person in charge

signed

B.I. Koshovskiy

<sup>17</sup> Gas sampling analysis is performed by RESPIRATOR Scientific Research Institute for Mining Rescue and Fire Safety

**JI MONITORING REPORT**

**APPROVED**

P.S.Pashkovskiy  
First Director Deputy, Science  
Activity, Dr. Sc. < signature >  
Seal  
The 10<sup>h</sup> of February, 2010

**Percentage of matters in fuel gas and ignition gas samples taken on 08.02.10  
at Lease Enterprise Mine named after A.F.Zasyadko**

<b>Main components</b>	<b>Fuel Gas, Concentration, %</b>	<b>Ignition Gas, Concentration, %</b>
Methane CH <sub>4</sub>	34,8	97,1
Ethan C <sub>2</sub> H <sub>6</sub>	0,19	0,58
Propane C <sub>3</sub> H <sub>8</sub>	0,07	0,07
Butane C <sub>4</sub> H <sub>10</sub>	0,009	0,003
Pentane C <sub>5</sub> H <sub>12</sub>	0,004	0,007
Hexane C <sub>6</sub> H <sub>14</sub>	0,0005	0,0006
Carbon Oxide CO	0,0005	0,007
Hydrogen H <sub>2</sub>	0,04	0,05
Carbon Dioxide CO <sub>2</sub>	0,04	n/a
Nitrogen N <sub>2</sub>	50,3	1,1
Oxygen O <sub>2</sub>	12,2	0,21
Argon Ar	0,33	n/a
<b>Micro-Components</b>	<b>mg/Nm<sup>3</sup></b>	
Ammonia NH <sub>3</sub>	n/a	n/a
Chlorine Cl <sub>2</sub>	n/a	n/a
Fluorine F <sub>2</sub>	n/a	n/a
Hydrogen sulphide H <sub>2</sub> S	0,02	n/a
Sulfide dioxide SO <sub>2</sub>	n/a	n/a
Dust, mg/m <sup>3</sup>	<1	2
Moisture, mg/m <sup>3</sup>	2320	2110

\* re-calculated per dry gas

Analysis person in charge

signed

B.I. Koshovskiy

Gas sample analysis – 2<sup>nd</sup> quarter 2010

**APPROVED**

P.S.Pashkovskiy  
 First Director Deputy, Science  
 Activity, Dr. Sc. < signature >  
 Seal  
 The 23<sup>rd</sup> of June, 2010

**Percentage of matters in samples of gas taken on 15.06.10  
 at Lease Enterprise Mine named after A.F.Zasyadko**

Main Components	Sampling Point		
	Vacuum Pump Station-1		Vacuum Pump Station -2
	First group	Second group	Second group
	Concentration, %		Concentration, %
Methane CH <sub>4</sub>	17,5	17,5	38,4
Ethan C <sub>2</sub> H <sub>6</sub>	0,07	0,07	0,5
Propane C <sub>3</sub> H <sub>8</sub>	0,02	0,02	0,06
Butane C <sub>4</sub> H <sub>10</sub>	0,007	0,007	0,009
Pentane C <sub>5</sub> H <sub>12</sub>	n/a	n/a	n/a
Hexane C <sub>6</sub> H <sub>14</sub>	n/a	n/a	n/a
Carbon Oxide CO	n/a	n/a	n/a
Hydrogen H <sub>2</sub>	n/a	n/a	n/a
Carbon Dioxide CO <sub>2</sub>	0,06	0,06	n/a
Nitrogen N <sub>2</sub>	66,1	66,1	50,3
Oxygen O <sub>2</sub>	14,1	14,1	9,6
Argon Ar	0,7	0,7	0,39
<b>Micro-Components</b>	<b>mg/Nm<sup>3</sup></b>		
Ammonia NH <sub>3</sub>	0,002	0,002	0,004
Chlorine Cl <sub>2</sub>	n/a	n/a	n/a
Fluorine F <sub>2</sub>	n/a	n/a	n/a
hydrogen sulphide H <sub>2</sub> S	0,008	0,008	n/a
Sulfide dioxide SO <sub>2</sub>	n/a	n/a	n/a
Dust, mg/m <sup>3</sup>	<1	<1	<1
Moisture, %	100	100	100

VPS 1 includes first and second set combined in common degasification line.

\* re-calculated per dry gas

Analysis person in charge

signed

B.I. Koshovskiy



## JI MONITORING REPORT

**APPROVED**

P.S.Pashkovskiy  
First Director Deputy, Science  
Activity, Dr. Sc. < signature >  
Seal  
The 23<sup>rd</sup> of June, 2010

**Percentage of matters in fuel gas and ignition gas samples taken on 15.06.10  
at Lease Enterprise Mine named after A.F.Zasyadko**

Main components	Fuel Gas, Concentration, %	Ignition Gas, Concentration, %
Methane CH <sub>4</sub>	33,6	97,5
Ethan C <sub>2</sub> H <sub>6</sub>	0,2	0,6
Propane C <sub>3</sub> H <sub>8</sub>	0,08	0,08
Butane C <sub>4</sub> H <sub>10</sub>	0,01	0,004
Pentane C <sub>5</sub> H <sub>12</sub>	0,005	0,008
Hexane C <sub>6</sub> H <sub>14</sub>	0,0006	0,0006
Carbon Oxide CO	0,0006	0,008
Hydrogen H <sub>2</sub>	0,05	0,06
Carbon Dioxide CO <sub>2</sub>	0,05	n/a
Nitrogen N <sub>2</sub>	51,2	1,6
Oxygen O <sub>2</sub>	14,0	0,7
Argon Ar	0,41	0,1
Micro-Components	mg/Nm <sup>3</sup>	
Ammonia NH <sub>3</sub>	n/a	n/a
Chlorine Cl <sub>2</sub>	n/a	n/a
Fluorine F <sub>2</sub>	n/a	n/a
Hydrogen sulphide H <sub>2</sub> S	n/a	n/a
Sulfide dioxide SO <sub>2</sub>	n/a	n/a
Dust, mg/m <sup>3</sup>	<1	2
Moisture, %	100	100

\* re-calculated per dry gas

Analysis person in charge

signed

B.I. Koshovskiy