

**JI MONITORING REPORT
ANNUAL REPORT**

**Version 1.0
February 01, 2010**

CONTENTS

- A. General project activity and monitoring information
- B. Key monitoring activities
- C. Quality assurance and quality control measures
- D. Calculation of GHG emission reductions

SECTION A. General Project activity information

A.1 Title of the project activity:

“Utilization of Coal Mine Methane at the Coal Mine named after A.F. Zasyadko”.

A.2. Registration number at JISC:

UA2000004

A.3. Short description of the project activity:

According to data of the mine, during four months (01.10.2009 — 31.01.2010) the following amount of methane has been utilized:

For electricity (and heat) m ³ (fuel gas)	12 537 487
For electricity (and heat) m ³ (ignition gas)	517 986
For AGFCP m ³	611 801
Total	13 667 273

Table 1: Amount of methane utilized during monitoring period.

The project is aimed to prevent emission of methane into atmosphere at Lease Enterprise Zasyadko Coal Mine, further referred to as Zasyadko or simply Mine. CMM extracted and recovered during mine works and because of ventilation of Mine, obtained from surface wells drilled into the gob at Zasyadko Coal Mine, is utilized for:

- Power production;
- Replacement of heat that is now generated by coal and gas boilers;
- Production of gas for motor vehicle fuelling.

Mine has four industrial sites: Vostochnaya, Yakovlevskaya, Centralnaya and Grigoryevskaya. During this monitoring period, one CHP at Vostochnaya site was in operation. The power generated at CHP was supplied in Mine's main, for Mine's local consumption. Heat generated by Vostochnaya CHP was feed for consumption at Vostochnaya site. Double-block automatic gas filling station at Vostochnaya site supply car fleet of Mine and other vehicles from neighbouring districts with fuel.

In the future, commissioning of the second CHP at Yakovlevskaya site is intended, and heat supply grid as well. This will make Mine able to feed excess power to general consumption grid, supply heat to Vostochnaya, Yakovlevskaya, and Centralnaya sites, and municipal heat supply grid. Besides, gas fuelling stations will be installed at Yakovlevskaya site.

A.4. Monitoring period:

- Monitoring period starting date: 01/10/2009;
- Monitoring period closing date: 31/01/2010.¹

A.5. Methodology applied to the project activity (incl. version number):

A.5.1. Baseline methodology:

The approved consolidated methodology ACM0008/Version 03 “*Consolidated baseline methodology for coal bed methane and coal mine methane capture and use for power (electrical or motive) and heat and/or destruction by flaring*”) has been used to identify the baseline scenario of this JI project. This methodology also refers to the “Tool for calculation of emission factor for electricity systems”, the latest version of the “Tool for the demonstration and assessment of additionality” and the latest version of the “Tool to determine project emissions from flaring gases containing methane”.

¹Both days were included. Monitoring period includes time from 00-00 01/10/09 up to 24-00 31/01/09.

JI MONITORING REPORT FORM

Monitoring Report #7 “Utilization of Coal Mine Methane at the Coal Mine named after A.F. Zasyadko” page 3

A.5.2. Monitoring methodology:

The approved consolidated methodology ACM0008/Version 03 “*Consolidated baseline methodology for coal bed methane and coal mine methane capture and use for power (electrical or motive) and heat and/or destruction by flaring*”) has been used to identify the baseline scenario of this JI project.

A.6. Status of implementation including timetable for major project parts:

Activity	Date
Commissioning of blocks (No.1,No.2) at gas filling compressor stations at Vostochnaya site	March 2004
Commissioning of new block No.3 at gas filling compressor station at Vostochnaya site	March 2005
Commissioning of the 1 st CHP modules at Vostochnaya site	January 2006
Commissioning of the 12 th CHP modules at Vostochnaya site	April 2006
Shut-down of boilers at Vostochnaya site	September 2006
Construction of vacuum pump station N 4 at Grigoryevskaya shaft with six vacuum pumps VVN-150 and build up 3 pipe lines	March 2007
Heat feeding from CHP units to, and shutdown of the boilers at Grigoryevskaya site	December 2011
Heat feeding from CHP units to, and shutdown of the boilers at Yakovlevskaya site	October 2010
Commissioning of the 1 st CHP unit at Yakovlevskaya site	December 2010
Commissioning of 6 CHP units at Yakovlevskaya site	December 2011
Heat supply to district heat supply system	December 2012

Table 2: Status of implementation (according to PDD version 4.4)

A.7. Intended deviations or revisions to the registered PDD:

There are no deviations from final version of PDD approved by JISC. A delay in the implementation schedule was noted as compared with implementation schedule from PDD as shown above. In view of this, within the monitoring period, following project parts were not introduced:

- Power: Yakovlevskaya CHP is not in operation at this moment. At this CHP, power generation is not running; as a result, GEN_{CHP} includes only net power generated by Vostochnaya CHP;
- Heat: during this monitoring period, infrastructure for heat supply of four sites of Mine and municipal heat supply grid are absent, save heat supply from Vostochnaya CHP to Vostochnaya site. In view of this, at this monitoring period, monitoring of following variable data was not performed: $HEAT_{deliv,DH,y}$; $HEAT_{deliv,yak,y}$; $HEAT_{deliv,centr,y}$. General amount of heat supplied is equal to amount of heat supplied from Vostochnaya CHP ($HEAT_{deliv,vost,y}$);
- Coal Mine Methane(CMM), utilized at CHP: As Yakovlevskaya CHP was not in operation during this monitoring period, CMM was not utilized at this CHP. Therefore, $MM_{CHP,y}$ included only CMM, utilized by Vostochnaya CHP;
- Coal Mine Methane(CMM) utilized at AGFCP. From five planned fuel stations (one- at Vostochnaya site, one- at Centralnaya site, and two-on Yakovlevskaya site), during this monitoring period, block gas filling station at Vostochnaya site has been operating. Therefore for $MM_{GAS,y}$ monitoring, only gas supply to these gas fueling station was used.

A.8. Intended deviations or revisions to the registered monitoring plan (Decision 17/CP.7, Annex H, paragraph 57 to be considered):

There are deviations in the monitoring plan compared to the final monitoring plan dd. 27 March 2008 as described in the PDD version 4.4. Below –mentioned metering devices have been substituted, and additions have been made to provide safety of parameters monitored. Calibration of all these devices has been performed (see below).Parameters as well as formulas have not been changed.

JI MONITORING REPORT FORM

Monitoring Report #7 “Utilization of Coal Mine Methane at the Coal Mine named after A.F. Zasyadko” page 5

From January 1, 2008, primary and secondary metering devices/ meters have been added/ substituted, because CHP unit measuring system was updated and improved. In addition, new metering device blocks for high concentration flow metering measurement have been installed:

- Universal 1 Metering system for ignition gas at CHP unit instead of Gn6 with their sensors;
- Universal 2 Metering system for fuel gas at AGFCP, additionally to gas fuelling stations equipment;
- BKTM Metering system for fuel gas in machine rooms, instead of Keuter device, ADM Electronic at gas treatment facility.

See more detailed description of layout and work of metering equipment in Section B.

A.9. Changes since last verification:

During 01/10/2009-31/01/2010, no changes occurred since last verification.

A.10. Person(s) responsible for the preparation and submission of the monitoring report:

Lease enterprise “Coal Mine named after A.F. Zasyadko”

- Boris Boki, Deputy General Director
- Yevgeniy Berezovskiy, CHP Chief;
- Valeriy Cherednikov, Monitoring Engineer, Gas Treatment Lead Engineer;

Carbon Emission Partnership LLC.

- Sergiy Apostolaka, Director.

SECTION B. Key monitoring activities according to the monitoring plan for the monitoring period stated in A.4.

The control and monitoring system can be divided into an electrical part, a heat part and a gas part.

Electrical measurements

There are no changes since last monitoring period.

Heat measurements

There are no changes since last monitoring period.

B.1. Monitoring equipment types

There are no changes since last monitoring period.

1. Electricity meters “Elster-Metronika”;
2. Heat meter SA-94/2 M;
3. Gas Analyzer ABB A02040 (for fuel and ignition methane);
4. DBT equipment. (for fuel and ignition methane);
5. DRGM flow meters (for fuel methane) as a part of BKTМ metering systems;
6. Metering system “Universal”.

B.1.2. Table providing information on metering equipment used (incl. manufacturer, type, serial number, date of installation, Date of calibration, information to specific uncertainty, need for changes and replacements):

The control and monitoring system can be divided into an electrical part, a heat part, and a gas part.

Electrical measurements

Following parameters shall be measured for emission reduction monitoring ²:

- GEN_{CHP} — net electricity generated by CHP under project(MWh);
- El_{cons} — net electricity consumed by Mine (MWh)³.

According to monitoring plan, initially excess or lack of net electricity amount was checked as generated by CHP in comparison to net electricity consumed by Mine. Actually, parameters measured are:

- $GEN_{CHP} = 43\ 975.052$ MWh;
- $EL_{cons} = 71\ 656.298$ MWh.

As net electricity amount generated by CHP under project is less than net electricity consumed by Mine, for emission reduction monitoring (see also page 40 of PDD), only amount of electricity generated by CHP is required. Net electricity generated by CHP is measured with two meters in power grid of Mine:

$$GEN_{CHP} (MWh) = E1 + E2 \tag{1.}$$

To perform cross-checking, electricity generated by CHP is summed up by way of addition of total electricity amount generated by each separate CHP unit excluding secondary electricity consumption by CHP itself. This calculation is performed under following formula.

$$GEN_{CHP} = \left(\sum_5^{16} E_{mod} - \sum_3^4 E_{aux} \right) = (E5 + E6 + E7 + E8 + E9 + E10 + E11 + E12 + E14 + E15 + E16) - (E3 + E4) \tag{2.}$$

Respective description of meters see in the table provided below. Because for check of electricity at high voltage, it is impossible to use data directly from meters, current and voltage transformers are used. In the first table, converted data for calculation of actual data are shown.

² Section D contains respective formulae from Monitoring Plan of PDD.

³ Net electricity consumption of Mine is demonstrated in the report of Chief Energy Engineer of the Mine according to data of thirteen commercial meters located at other 110 kV substations.

JI MONITORING REPORT FORM

Monitoring Report #7 “Utilization of Coal Mine Methane at the Coal Mine named after A.F. Zasyadko” page 7

Electricity Meters

Number	Metering instrument	Work parameter kWh, kVar	Manufacturer	Type	Serial Number	Accuracy	Date of installation	Date 01.10.2009	Date 31.01.2010	Difference	Date of calibration	Date of next calibr.	Remarks
E1	Electricity meter at CHP system (6 kV) Wireway	Net electricity generated by CHP system. P,Q	“Elster-Metronika” Russia	Electronic	№ 01116374	0.2S	N/A	6468,9487	7033,8674	564,9187	14.05.2005	14.05.2011	Double side. Cubicle No.A21
E2	Electricity meter at CHP system (6 kV) Wireway	Additional electricity generated by CHP system. P,Q	“Elster-Metronika” Russia	Electronic	№ 01116376	0.2S	N/A	6821,5027	7419,9454	598,4427	14.05.2005	14.05.2011	Double side. Cubicle No.B22
E17	Commercial electricity meter 110 kV	Consumption of electricity from or supply Ukrainian grid with	“Elster-Metronika” Russia	Electronic	№ 01194835	0.2S	N/A	98,1260	182,1430	84,0170	N/A Belongs to supply company	N/A	Substation 110kV T1
E18	Commercial electricity meter 110 kV	Consumption of electricity from or supply Ukrainian grid with	“Elster-Metronika” Russia	Electronic	№ 01194834	0.2S	N/A	57,7610	120,9750	63,2140	N/A Belongs to supply company	N/A	Substation 110kV T2

JI MONITORING REPORT FORM

Monitoring Report #7 “Utilization of Coal Mine Methane at the Coal Mine named after A.F. Zasyadko” page 8

Number	Metering instrument	Work parameter kWh, kVar	Manufacturer	Type	Serial Number	Accuracy	Date of installation	Date 01.10.2009	Date 31.01.2010	Difference	Date of calibration	Date of next calibr.	Remarks
E3	Electricity meter at CHP system (6 kV) Auxiliary transformer	Electricity consumed by CHP system, P, Q	“Elster-Metronika” Russia	Electronic	№ 01103251	0.2S	N/A	3459,6690	3752,4880	292,8190	03.09.2004	03.09.2010	Cubicle No.1
E4	Electricity meter at CHP system (6 kV) Auxiliary transformer	Electricity consumed by CHP system, P, Q	“Elster-Metronika” Russia	Electronic	№ 01103208	0.2S	N/A	3576,4570	3822,1797	245,7227	03.09.2004	03.09.2010	Cubicle No.2
E5	Electricity meters at individual CHP modules (6 kV) No.1	Gross electricity generated by CHP system P,Q	“Elster-Metronika” Russia	Electronic	№ 01117846	0.2S	N/A	7279,1460	8129,5781	850,4321	16.06.2005	16.06.2011	Double side. Cubicle No.5
E6	Electricity meters at individual CHP modules (6 kV) No.3	Gross electricity generated by CHP system P,Q	“Elster-Metronika” Russia	Electronic	№ 01117849	0.2S	N/A	8197,4910	9098,6994	901,2084	16.06.2005	16.06.2011	Double side. Cubicle No.7
E7	Electricity meters at individual CHP modules (6 kV) No.5	Gross electricity generated by CHP system P,Q	“Elster-Metronika” Russia	Electronic	№ 01117851	0.2S	N/A	8758,3080	9527,5425	769,2345	16.06.2005	16.06.2011	Double side. Cubicle No.9
E8	Electricity meters at individual CHP modules (6 kV) No.7	Gross electricity generated by CHP system P,Q	“Elster-Metronika” Russia	Electronic	№ 01117852	0.2S	N/A	8286,1090	8841,6374	555,5284	16.06.2005	16.06.2011	Double side. Cubicle No.11
E9	Electricity meters at individual CHP modules (6 kV) No.9	Gross electricity generated by CHP system P,Q	“Elster-Metronika” Russia	Electronic	№ 01117855	0.2S	N/A	9582,9110	10310,7592	727,8482	16.06.2005	16.06.2011	Double side. Cubicle No.13
E10	Electricity meters at individual CHP modules (6 kV) No.11	Gross electricity generated by CHP system P,Q	“Elster-Metronika” Russia	Electronic	№ 01117856	0.2S	N/A	9139,1590	9995,2307	856,0717	16.06.2005	16.06.2011	Double side. Cubicle No.15

JI MONITORING REPORT FORM

Monitoring Report #7 “Utilization of Coal Mine Methane at the Coal Mine named after A.F. Zasyadko” page 9

Number	Metering instrument	Work parameter kWh, kVar	Manufacturer	Type	Serial Number	Accuracy	Date of installation	Date 01.10.2009	Date 31.01.2010	Difference	Date of calibration	Date of next calibr.	Remarks
E11	Electricity meters at individual CHP modules (6 kV) No.2	Electricity consumed by CHP system, P, Q	“Elster-Metronika” Russia	Electronic	№ 01117848	0.2S	N/A	9854,3730	10576,8271	722,4541	16.06.2005	16.06.2011	Cubicle No.6
E12	Electricity meters at individual CHP modules (6 kV) No.4	Electricity consumed by CHP system, P, Q	“Elster-Metronika” Russia	Electronic	№ 01122645	0.2S	N/A	4987,9100	5768,3828	780,4728	10.08.2005	10.08.2011	Cubicle No.8
E13	Electricity meters at individual CHP modules (6 kV) No.6	Gross electricity generated by CHP system P,Q	“Elster-Metronika” Russia	Electronic	№ 01122650	0.2S	N/A	8475,1990	9159,4363	684,2373	10.08.2005	10.08.2011	Double side. Cubicle No.10
E14	Electricity meters at individual CHP modules (6 kV) No.8	Gross electricity generated by CHP system P,Q	“Elster-Metronika” Russia	Electronic	№ 01117845	0.2S	N/A	10390,0020	11296,2496	906,2476	16.06.2005	16.06.2011	Double side. Cubicle No.12
E15	Electricity meters at individual CHP modules (6 kV) No.10	Gross electricity generated by CHP system P,Q	“Elster-Metronika” Russia	Electronic	№ 01132765	0.2S	N/A	9796,8460	10381,2932	584,4472	09.02.2006	09.02.2012	Double side. Cubicle No.14
E16	Electricity meters at individual CHP modules (6 kV) No.12	Gross electricity generated by CHP system P,Q	“Elster-Metronika” Russia	Electronic	№ 01132766	0.2S	N/A	6238,0600	6931,0261	692,9661	09.02.2006	09.02.2012	Double side. Cubicle No.16

Calibration interval for electricity meters is six years.

As it is impossible to use meters data directly to check electricity generated we have to take in account special coefficients which is appears from multiplying of coefficients transformation for current and voltage transformers connected to each meter. Their data are presented in table below.

In view of high voltage and currents, it is impossible to obtain direct data from electricity meters on generation and consumption of electricity without current and voltage transformers, for accounting of equipment operation. The calculation method is following: example for meter No. 01116374: Current $-3000/5= 600$ A; voltage- $6300/100=63$ V (gross factor $-600 \times 63 =37800$ VA). *Date on meter -564,9187. Electricity to be accounted with this meter makes up: $564,9187 \times 600 \times 63=21\ 353\ 926,9$ VA = 21 353 926,9 kW*

JI MONITORING REPORT FORM

Monitoring Report #7 "Utilization of Coal Mine Methane at the Coal Mine named after A.F. Zasyadko" page 10

Number	Metering instrument	Work parameter kWh, kVar	Type	Serial Number	Current transformer	Voltage transformer	Coefficient for calculations	Electricity Amount
E1	Electricity meter at CHP system (6 kV) Wireway	Net electricity generated by CHP system, P,Q	Electronic	№ 01116374	3000/5	6300/100	37800	21 353 926,9
E2	Electricity meter at CHP system (6 kV) Wireway	Net electricity generated by CHP system, P,Q	Electronic	№ 01116376	3000/5	6300/100	37800	22 621 134,1
E3	Electricity meter at CHP system (6 kV) Auxiliary transformer	Electricity consumed by CHP system, P, Q	Electronic	№ 01103251	200/5	6300/100	2520	737 903,9
E4	Electricity meter at CHP system (6 kV) Auxiliary transformer	Electricity consumed by CHP system, P, Q	Electronic	№ 01103208	200/5	6300/100	2520	619 221,2
E5	Electricity meters at individual CHP modules (6 kV) No.1	Gross electricity generated by CHP system, P,Q	Electronic	№ 01117846	400/5	6300/100	5040	4 286 177,8
E6	Electricity meters at individual CHP modules (6 kV) No.3	Gross electricity generated by CHP system P,Q	Electronic	№ 01117849	400/5	6300/100	5040	4 542 090,3
E7	Electricity meters at individual CHP modules (6 kV) No.5	Gross electricity generated by CHP system P,Q	Electronic	№ 01117851	400/5	6300/100	5040	3 876 941,9
E8	Electricity meters at individual CHP modules (6 kV) No.7	Gross electricity generated by CHP system P,Q	Electronic	№ 01117852	400/5	6300/100	5040	2 799 863,1
E9	Electricity meters at individual CHP modules (6 kV) No.9	Gross electricity generated by CHP system P,Q	Electronic	№ 01117855	400/5	6300/100	5040	3 668 354,9
E10	Electricity meters at individual CHP modules (6 kV) No.11	Gross electricity generated by CHP system P,Q	Electronic	№ 01117856	400/5	6300/100	5040	4 314 601,4
E11	Electricity meters at individual CHP modules (6 kV) No.2	Gross electricity generated by CHP system P,Q	Electronic	№ 1117848	400/5	6300/100	5040	3 641 168,7
E12	Electricity meters at individual CHP modules (6 kV) No.4	Gross electricity generated by CHP system P,Q	Electronic	№ 01122645	400/5	6300/100	5040	3 933 582,9

JI MONITORING REPORT FORM

Monitoring Report #7 "Utilization of Coal Mine Methane at the Coal Mine named after A.F. Zasyadko" page 11

Number	Metering instrument	Work parameter kWh, kVar	Type	Serial Number	Current transformer	Voltage transformer	Coefficient for calculations	Electricity Amount
E13	Electricity meters at individual CHP modules (6 kV) No.6	Net electricity generated by CHP system, P,Q	Electronic	№ 01122650	400/5	6300/100	5040	3 448 556,0
E14	Electricity meters at individual CHP modules (6 kV) No.8	Net electricity generated by CHP system, P,Q	Electronic	№ 01117845	400/5	6300/100	5040	4 567 487,9
E15	Electricity meters at individual CHP modules (6 kV) No.10	Electricity consumed by CHP system, P, Q	Electronic	№ 01132765	400/5	6300/100	5040	2 945 613,9
E16	Electricity meters at individual CHP modules (6 kV) No.12	Electricity consumed by CHP system, P, Q	Electronic	№ 01132766	400/5	6300/100	5040	3 492 549,1
E17	Commercial electricity meter 110 kV	Consumption of electricity from or supply Ukrainian grid with	Electronic	№ 01194835	150/5	110000/100	33000	2 772 561,0
E18	Commercial electricity meter 110 kV	Consumption of electricity from or supply Ukrainian grid with	Electronic	№ 01194834	150/5	110000/100	33000	2 086 062,0

JI MONITORING REPORT FORM

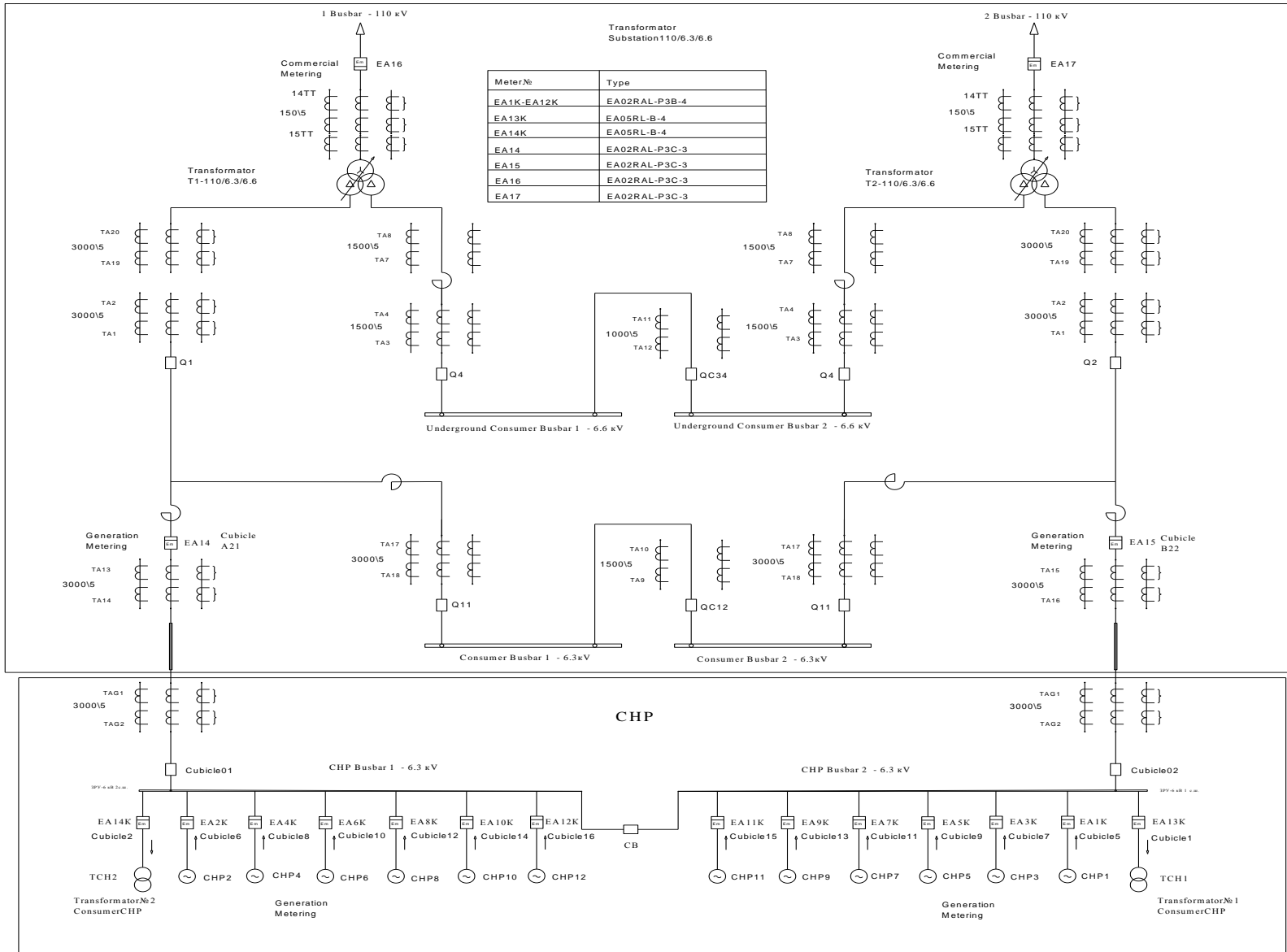

Figure 1: Electricity Metering Scheme for Vostochnaya CHP

JI MONITORING REPORT FORM

Monitoring Report #7 “Utilization of Coal Mine Methane at the Coal Mine named after A.F. Zasyadko” page 13

Heat Meter Heat measurements

For this monitoring period, only heat is considered that was directly fed by Vostochnaya CHP, as described in paragraph A.7. Therefore, for this monitoring period, only one variable is measured that expresses heat amount fed by CHP system to heat supply pipelines, and is equal to heat amount consumed by Vostochnaya site.

Metering instrument	Work parameter Gcal	Manufacturer	Type	Serial number	accuracy	Date of installation	Date 01.10.2009 Gcal	Date 31.01.2010 Gcal	Difference	Date of calibration	Date of next calibr.	Remarks
Heat meter SA 94/2M ⁴	Amount of heat delivered to site system	ASWEGA	Mechatronic	22903	Heat- 4 Flow-2	N/A	95 238,83	110 890,89	15 652,06	04.06.09	04.06.11	T,V,Q (Total)

Calibration interval for heat meters is two years

⁴For meter SA 94/2M DN=300mm; Q=1000m³/h

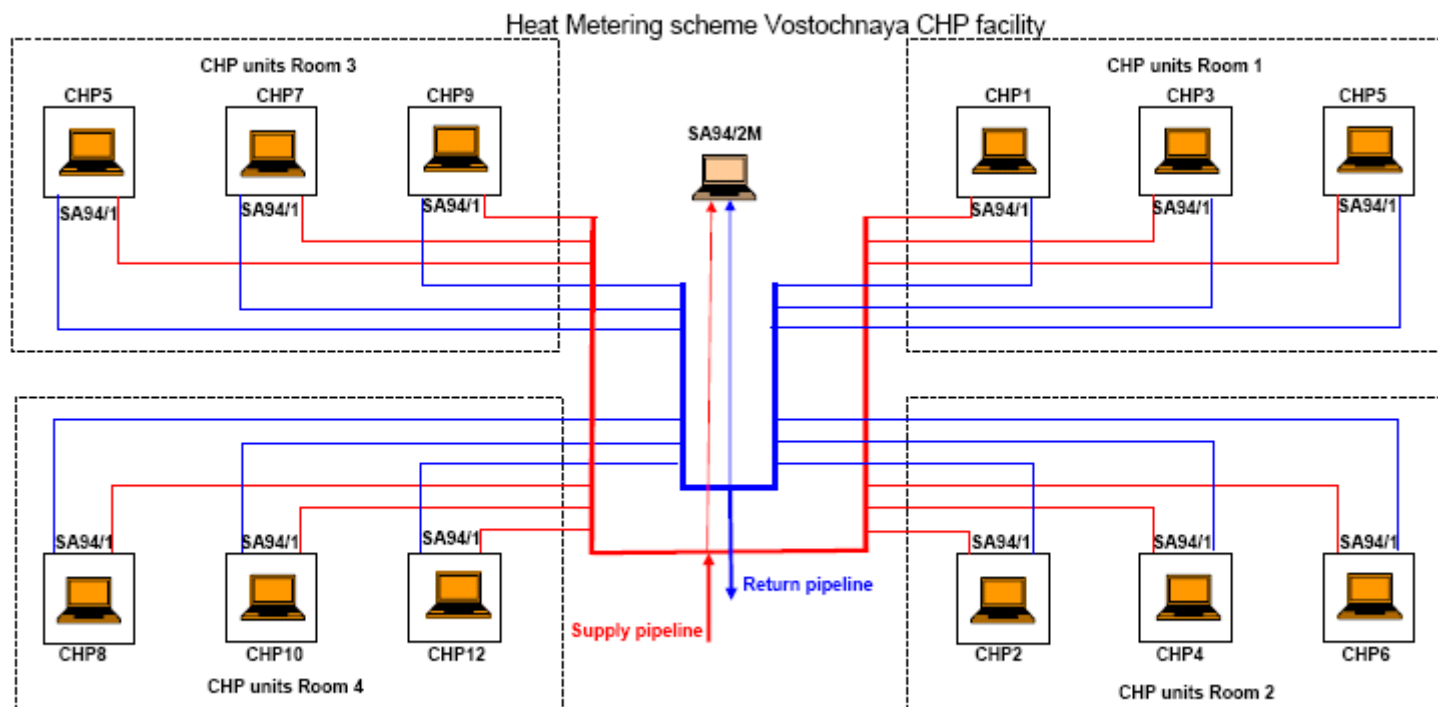

Figure 2: Heat Metering Scheme for Vostochnaya CHP Facility

CMM Meters

Measurement of CMM consumption

According to monitoring plan, two variables are measured:

- MM_{CHP}- measured amount of methane fed to CHP units (tCH₄);
- MM_{GAS}- measured amount of methane fuelled in vehicles at new automotive gas filling stations (tCH₄).

Variable MM_{CHP} has two components: fuel gas consumption and ignition gas consumption. To determine the amount of pure consumed CH₄ (in tonnes) the amount of pure CH₄ (in m³) has to be measured under normal conditions⁵. The amount of pure CH₄ (in m³) can be measured (or more correctly: calculated) based on four parameters:

- Concentration (%) of CH₄ in the gas mixture
- Flow (m³) of gas mixture
- Temperature (°C) of gas mixture
- Pressure (bar) of gas mixture

In the scheme below the different meters and sensors are indicated that are installed at the Vostochnaya site. We can classify the different meters/sensors:

- Scheme of location of main primary meters/sensors that supply the data for determining the emission reductions as provided in section D of the Monitoring Report;
- General scheme of location of meters/sensors (with addition of secondary meters/ sensors) used for cross-checking the data of the primary meters, as well as meters/sensors used to operated and control the installation.

The secondary meters/sensors are not of interest for monitoring purposes and are not mentioned further. In the table below the primary and secondary meters/sensors are indicated with their number which listed in the scheme.

	Primary meters/sensors	Secondary meters/sensors
Fuel gas		
Concentration (%)	ABB AO 2040 (A1)	K1-K6
Flow (V)	G1-G12	Gn1-Gn6
Temperature (T)	T6-T17	Gn5 sensor
Pressure (P)	P11-P22	P6(Gn5's sensor)
Unit for methane keeping (m3)	BKT.M ⁶ metering system	DBT equipment
Ignition gas		
Concentration (%)	ABB AO 2040 (A2)	ABB AO 2040 (A2)
Flow (V)	G13	
Temperature (T)	T2	
Pressure (P)	P10	
Unit for methane keeping (m3)	"Universal" ⁷ metering system	Pressure sensors on pipeline
AGFCP gas		
Concentration (%)	ABB AO 2040 (A2)	ABB AO 2040 (A2)
Flow (V)	G14	Calculations according to pressure difference
Temperature (T)	T1	
Pressure (P)	P5	Manometers at AGFCS
Unit for methane keeping (m3)	"Universal" ⁷ metering system	Calculations

Table 3: Primary and secondary (cross-checking) metering of CMM

⁵ Normal conditions=273K and 760 mm Hg.

⁶ BKT.M is designed for conversion of input data of gas parameters and calculation on the base thereof of amount and volumetric gas flow brought to standard conditions, in the composition of DRG.M meter.

⁷ Universal is designed for conversion of input data of gas parameters and calculation on the base thereof of amount and volumetric gas flow brought to standard conditions.

MM_{CHP} – is an amount of fuel gas consumption at each CHP unit, including one ignition gas metering device, represented as following:

$$MM_{CHP} = \left(\sum_1^{12} VM_n \cdot C_1 + V_1 \cdot C_2 \right) \cdot 0,7167 \cdot 0,93, \quad (3.)$$

where:

- VM_n — fuel gas consumption by separated CHP unit, brought to standard ⁸ conditions (m³);
- $C_{1,2}$ — CH₄ concentration sensors (%);
- V_1 — amount of methane fed as ignition gas (m³);
- 0,7167 — methane density in normal conditions (kg/m³);
- 0,93 — standard conditions to normal conditions conversion ratio

Fed MM_{GAS} to be measured as following:

$$MM_{GAS} = V_2 \cdot C_2 \cdot 0,7167 \cdot 0,93, \quad (4.)$$

where:

- V_2 — amount of methane fed as fuel for vehicles, in standard conditions (m³);
- C_2 — CH₄ concentration sensor (%);
- 0,7167 — methane density in normal conditions (kg/m³);
- 0,93 — standard conditions to normal conditions conversion ratio.

Sensors represented in tables, shown after general description of methane consumption process.

Crosschecking

Amount of methane used as fuel gas for CHP units undergoes crosschecking. This operation is performed by way of measurement of total amount of gas consumption (m³), that is defined by flow meter который Gn5 (Keuter), which has structure as block of velocity, pressure and temperature sensors that measure amount of gas consumed by CHP units and data on methane concentration in point A1 with gas analyzer AO 2040 (ABB). Amount of methane to be calculated on the base of these data, but it is not used for database formation; it is used only for technological purposes and for crosschecking and control of CHP operation systems. This procedure is carried out on regular basis. Summary results of the internal cross checkings from 01.10.2009 until 31.01.2010 are presented in the table below

01.10.2009 — 31.01.2010				
month	Q Fuel Gas Consumption, m3/month	F Fuel Gas, Net Consumption, m3/month	Q Fuel Gas, Net Consumption, m3/month	Relative Difference in Readings Gn5*CH4/100 and \sum БКТ.М1- БКТ.М4, %
	Gn5	Gn5 * CH4/100	\sum БКТ.М1-БКТ.М4	
October 2009	11 047 368,16	3 118 209,74	3 118 445,30	-0,01
November 2009	9 967 648,01	2 833 054,23	2 833 713,94	-0,02
December 2009	11 296 394,04	3 248 807,50	3 250 375,90	-0,05
January 2010	11 446 347,26	3 336 809,99	3 334 951,48	0,06
Total	43 757 757,47	12 536 881,46	12 537 486,62	0,00

Table 4. Summary results of cross checking

⁸ Standard conditions=293K and 760 mm Hg.

Scheme of location of main meters /sensors at Vostochnaya CHP in 2009 - 2010

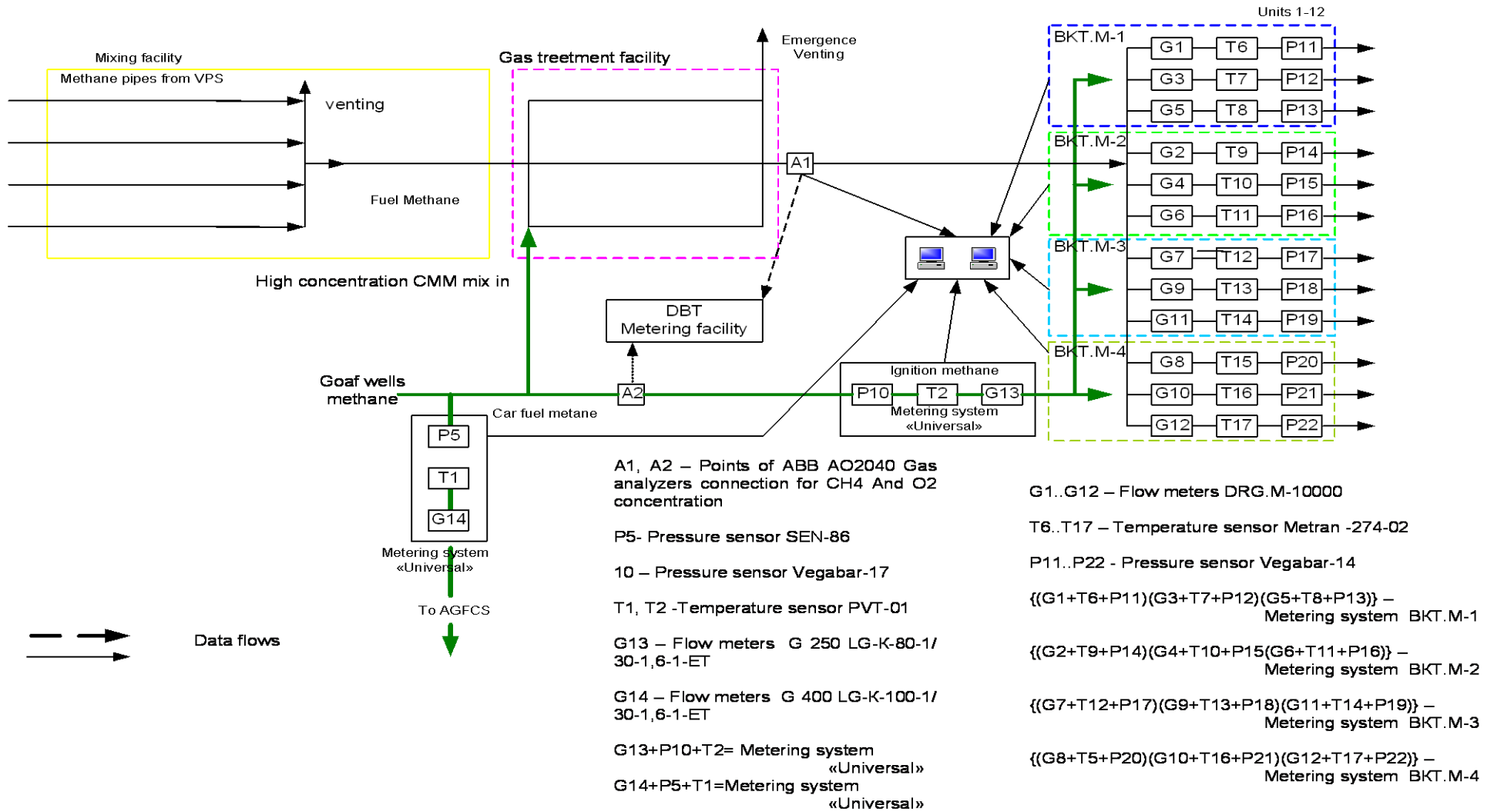

Figure 3 Scheme of location of primary meters/ sensors

General scheme of location of meters /sensors at Vostochnaya CHP in 2009 - 2010

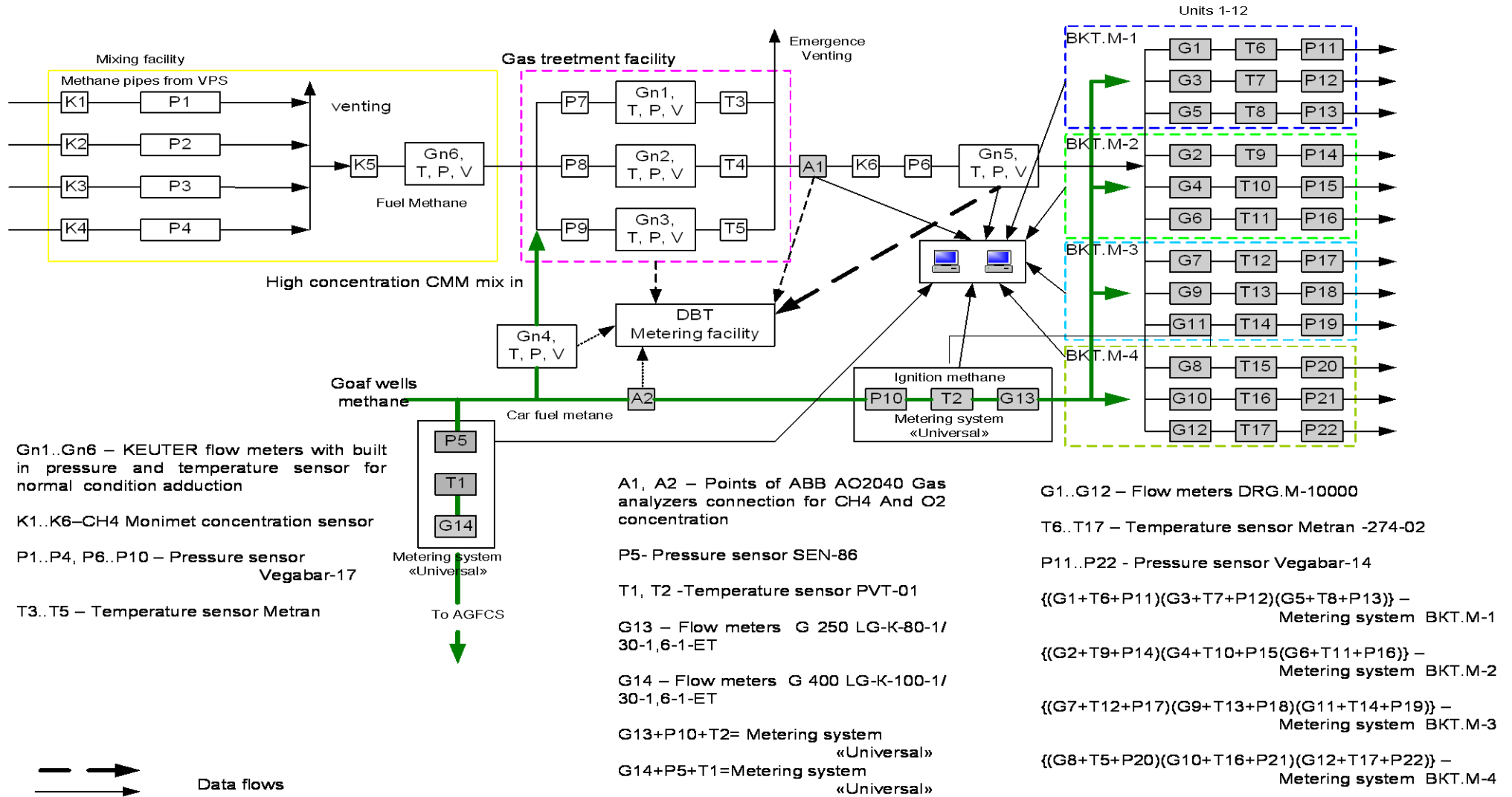

Figure 4. General scheme of location of meters/ sensors including secondary meters/sensors

The general flow of CMM and the metering can be described as follows.⁹

Coal mine gas of degassing and gas-suction is supplied through four lines from two Vacuum Pump Station (VPS) to gas mixing section of the CHP gas treatment facility. The concentration and pressure of methane are different in each pipe-line. These parameters are measured by K1...K4 (Monimet) concentration sensors and P1...P4 (Vegabar) pressure sensors. Measurements data of these sensors are not used in gas metering and have technological meaning; these data are channelled to automatic control system of the dispatch and used only for controlling purposes in order to obtain at the output homogeneous fuel methane with necessary concentration.

Concentration of methane that is fed to the gas treatment facility is measured by the sensor K5 (Monimet); temperature, pressure and flow are measured by flow meters Gn6 (Keuter), a unit of velocity, pressure, and temperature sensors. Surface well methane is mixed with fuel gas, if increase of its concentration is required. Admix (flow), temperature, and pressure of surface well methane is measured by flow meter Gn4 (Keuter) a unit of velocity, pressure, and temperature sensors. The concentration of admix methane from surface wells is measured by gas analyser AO 2040 (ABB0 in A2 point (concentration of methane in admix and ignition gas are equal as these are included in common system of surface degasification- surface well gas methane). Having all this data the automatic control system of the dispatch can calculate amount of methane in the gas mixture.

At the gas treatment section of facility, methane is distributed between three lines where it is dried, cooled, cleaned and warmed. Acting flow measurements is provided by Gn1 - Gn3 (Keuter) flow meters together with velocity, pressure and temperature sensors. They transmit information to calculation equipment developed by DBT which is installed in separate premise. This unit calculates the values of actual consumption for normal conditions and channelled them to automatic control system of the dispatch computer system for operation and saving in database. For checking and reserve, pressure sensors P7 - P9 (Vegabar) and temperature sensors T3 - T5 (Metran) have been installed in pipe-lines.

At the outflow of gas treatment section the processing discharge valve is installed which levels out e pressure swings at abrupt changes of CHP operation regime. Pressure at the outflow of the section is controlled by processing sensor P6 (Vegabar).

With the purpose of fuel gas concentration definition, gas testing is made at the outflow of gas treatment section of facility in point A1 which is fed to gas analyzer AO 2040 (ABB) mounted at gas metering unit. Concentration measured is checked for the compliance with sensor K6 (Monimet). Flow meter Gn5 (Keuter) as a unit with velocity, pressure and temperature sensors, measures the gas amount used by CHP units. The methane amount is calculated based on the data of methane concentration but is not used for database establishment and metering, it is used only for technological purposes.

Further, fuel gas is supplied to the units of CHPs engine rooms. The flow meters G1- G12, type DPG.M-10000. temperature sensors T6 - T17 (Metran 274-02), and pressure sensors P11 - P22 (Vegabar -14) are mounted on the line of each 12 units. Their data are transmitted to micro- processing control system BKT.M designed for transformation of input information about gas parameters and for calculation of the base thereof of amount and volumetric amount of gas flow brought to standard conditions to calculate fuel gas amount which is used by each unit, and total amount in each engine room. Fuel gas amount is calculated based on the data of methane concentration in it. Fuel gas amount calculation is performed on the base of data received from control units for gas record BKT.M1-BKT.M4, and concentration of methane therein as received from gas analyzer AO 2040 (ABB) in point A1. Total amount of fuel gas is calculated by way of addition of figures of all gas record units BKT.M, and serves as a figure of CHP gas methane utilized. This information is entered into database and logs.

Ignition gas is supplied to CHP units from gas pipes of surface degasification wells. Total ignition gas consumption is metered by system Universal designed for transformation of input information about gas parameters and for calculation of the base thereof of amount and volumetric amount of gas flow brought to standard conditions, which included gas metering device G13 (G 250 LG-K-80-1/30-1,6-1-Ex), temperature sensor T2 (PVT-01-1), and pressure sensor P10 (Vegabar-17). Gas concentration is metered by gas analyzer AO 2040 (ABB) with gas test in the point A2. Based on data received from metering system Universal, ignition gas automatic control system is kept, which gas is supplied to CHP units and recorded in database and log.

⁹ From 2008, DBT equipment is used as equipment for operation and control of stations, as well as for crosschecking. Main meters are installed at each CHP unit, and they transmit data to metering systems of the gas record units BKT.M. Gas record units BKT.M transmit data to computer. Each gas record unit BKT.M covers 3 CHP units. These systems are operated with fuel gas. Ignition gas for all CHP units is metered with a new metering system Universal. All this data are stored in place, and are transmitted to CHP computer system.

Gas that is supplied for motor vehicles filling is also supplied from gas pipes of surface degasification wells. Total motor vehicle filling gas consumption G14 is metered by system Universal designed for transformation of input information about gas parameters and for calculation of the base thereof of amount and volumetric amount of gas flow brought to standard conditions, which included gas metering device G14 (G 400 LG-K-100-1/30-1,6-1-Ex), temperature sensor T2 (PVT-01-1), and pressure sensor P5 (CEN-8601). As the gas for vehicle fuelling and ignition gas fed to CHP units are of one system of surface degasification, gas concentration control is performed by gas analyzer AO 2040 (ABB) with gas test in the point A2. Based on data thereof, amount of methane fed to AGFCP for motor vehicle filling, is recorded in database and log.

Methane volume which is supplied with fuel gas and methane of ignition gas gives total amount of methane supplied to CHPs.

Methane volume which is supplied with fuel gas and methane of ignition gas, methane for automobiles filling give total amount of methane consumed by Vostochnaya site of Zasyad’ko coal mine.



Figure 5: Gas flow meter DRG.M-10000¹⁰, temperature sensor Metran 274-02 and pressure sensor Vegabar-14 of metering system for gas record BKT.M at fuel gas pipeline of CHP unit.

¹⁰ DRG.M – 10000 — gas flow meter designed for transformation of volumetric flow of gas (at operational pressure) into numeric and impulsive signal.

JI MONITORING REPORT FORM

Monitoring Report #7 "Utilization of Coal Mine Methane at the Coal Mine named after A.F. Zasyadko" page 21

In the table below the description of the meters/sensors of metering systems for gas record that are part of monitoring report drawing, are given:

CHP gas metering equipment

Item No.	Metering instrument design	Work parameter	Manufacturer	Type	Serial number	Uncertainty level of data	Date of installation	Date of calibration	Date of next calibr.	Remarks
C1	Concentration of fuel gas	%	ABB	AO2040 Electronic	3.244705.5	±1%	2005	10.07.08 09.07.09	09.07.10	Connection A1
C2	Concentration of ignition gas	%	ABB	AO2040 Electronic	3.244704.5	±1%	2005	11.07.08 10.07.09	10.07.10	Connection A2

Calibration interval for gas analyzers is one year.

Ignition gas record system Universal meters/sensors

Item No.	Gas to be measured	Metering instrument design	Work parameter	Manufacturer	Type	Serial number	Uncertainty level of data	Date of installation	Date of calibration	Date of next calibr.	Remarks
V1	Ignition	Ignition gas amount measurement	m ³	NVP "GREMPIS" ltd	G 250 LGK-80-1/30-1,6-1-Ex	9771	±2%	4 quarter 2007	23.03.07 10.03.09	10.03.11	Connection G13
		Ignition gas temperature measurement	°C	NVP "GREMPIS" ltd	PVT-01-1	6480	±0.5%	4 quarter 2007	23.07.08 10.03.09	10.03.11	Connection T2
		Ignition gas pressure measurement	bar	"VEGA" Germany	Vegabar-17	1230727 8	±0.5%	4 quarter 2007	23.07.08 10.03.09	10.03.10	Connection P10

Calibration interval for pressure sensor is one year.

Calibration interval for temperature sensor and gas meter is once in two years.

JI MONITORING REPORT FORM

Monitoring Report #7 "Utilization of Coal Mine Methane at the Coal Mine named after A.F. Zasyadko" page 22

Motor vehicle filling gas metering system Universal meters/ sensors

Item No.	Gas to be measured	Metering instrument design	Work parameter	Manufacturer	Type	Serial number	Uncertainty level of data	Date of installation	Date of calibration	Date of next calibr.	Remarks
V2	Gas for motor vehicle filling	gas for motor vehicle filling amount measurement	m ³	NVP "GREMPIS" ltd	G 400 LGK-100-1/30-1,6-1-Ex	9786	±2%	4 quarter 2007	16.07.07 15.07.09	15.07.11	Connection G14
		Gas for motor vehicle filling temperature measurement	°C	NVP "GREMPIS" ltd	PVT-01-1	211	±0.5%	4 quarter 2007	28.07.08 28.07.09	28.07.11	Connection T1
		Gas for motor vehicle filling pressure measurement	bar	"COBOLD" Germany	SEN-86	45	±0.5%	4 quarter 2007	28.07.08 28.07.09	28.07.10	Connection P5

Calibration interval for pressure sensor is one year.

Calibration interval for temperature sensor and gas meter is once in two years.

JI MONITORING REPORT FORM

Monitoring Report #7 “Utilization of Coal Mine Methane at the Coal Mine named after A.F. Zasyadko” page 23

Gas volume and volumetric consumption computing block

Item No.	Metering system	Work parameter: m ³ /h	manufacturer	Type	Serial number	Uncertainty level of data and accuracy	Date of installation	Data as of 01.10.2009 m ³	Data as of 31.01.2010 m ³	Difference	Date of calibration	Date of next calibration	Remarks
V ₁	Universal	Ignition gas amount	NVP"GREMPIS" ltd	Universal -2	6023	±0.2 %	4 quarter 2007	3 228 583,3	3 785 557,5	556 974,2	23.07.08 10.03.09	10.03.11	Main metering block
V ₂	Universal	Motor vehicle fuelling gas amount	NVP"GREMPIS" ltd	Universal -2	327	±0.2 %	4 quarter 2007	4 959 363	5 617 218	657 855	28.07.08 15.07.09	15.07.11	Main metering block

Calibration interval-once in two years.

Gas volume and volumetric consumption computing blocks BKT.M -1 — BKT.M-4

Item No.	Metering system	Work parameter: m ³	Manufacturer	Serial number	Uncertainty level of data and accuracy	Date of installation	Unit No.	Data as of 01.10.2009 m ³	Data as of 31.01.2010 m ³	Difference	Date of calibration	Date of next calibration	Remarks	
V ₃	BKT.M-1	Fuel gas amount	Sibnefteavtomatika, Russia	245	<ul style="list-style-type: none"> • Pressure channels, not exceeding ±0.3 %; • Temperature channels, not exceeding ±0.5 %; • Consumption channels, not exceeding ±0.1 %; • Gas consumption definition status brought to standard conditions, not exceeding ±0.35 %; • Gas amount definition status brought to standard conditions, not exceeding ±0.35 %; • Change of running time, not exceeding ±0.1 %. 	N/A	M1	23 522 956	27 919 390	4 396 434	21.08.07	21.08.10	Main metering block	
							M3	22 806 312	27 511 388	4 705 076				
							M5	22 931 054	26 938 344	4 007 290				
V ₄	BKT.M-2	Fuel gas amount	Sibnefteavtomatika, Russia	095			N/A	M2	7 562 053	11 325 665	3 763 612	20.01.09	20.01.12	Main metering block
								M4	664 465,8	4 766 843	4 102 377,2			
								M6	6 833 283	10 404 930	3 571 647			
V ₅	BKT.M-3	Fuel gas amount	Sibnefteavtomatika, Russia	100			N/A	M7	14 110 627	17 001 216	2 890 589	18.03.08	18.03.11	Main metering block
								M9	20 274 942	24 120 722	3 845 780			
								M11	19 592 724	24 048 170	4 455 446			
V ₆	BKT.M-4	Fuel gas amount	Sibnefteavtomatika, Russia	099			N/A	M8	12 085 073	16 810 326	4 725 253	05.08.08	05.08.11	Main metering block
								M10	12 237 045	15 330 485	3 093 440			
								M12	737 785,6	4 339 246	3 601 460,4			

JI MONITORING REPORT FORM

Monitoring Report #7 “Utilization of Coal Mine Methane at the Coal Mine named after A.F. Zasyadko” page 24

Meters/ sensors of fuel gas metering system BKT.M – 1

Item No.	Gas to be metered	Symbol on scheme	Metering device designation	Work parameter	Manufacturer	Type	Serial number	Allowed uncertainty	Date of installation	Date of calibration	Date of next calibration	Remarks
M1	Fuel	G1	Fuel gas amount measurement	m3	Sibnefteavtomatika, Russia	DRG.M-10000 Electronic	102	±1.0%	N/A	16.07.08 19.08.09	19.08.11	Fuel gas metering system BKT.M-1
		T6	Fuel gas temperature measurement	°C	Metran Industrial Group, Russia	Metran -274-02	510745	±0,5%	N/A	22.07.08 22.07.09	22.07.10	
		P11	Fuel gas pressure measurement	bar	"VEGA" Germany	Vegabar 14	14536534	±0,5%	N/A	04.06.08 04.06.09	04.06.10	
M3	Fuel	G3	Fuel gas amount measurement	m3	Sibnefteavtomatika, Russia	DRG.M-10000 Electronic	109	±1.0%	N/A	18.07.08 19.08.09	19.08.11	
		T7	Fuel gas temperature measurement	°C	Metran Industrial Group, Russia	Metran -274-02	510753	±0,5%	N/A	04.07.08 03.07.09	03.07.10	
		P12	Fuel gas pressure measurement	bar	"VEGA" Germany	Vegabar 14	14536342	±0,5%	N/A	04.06.08 04.06.09	04.06.10	
M5	Fuel	G5	Fuel gas amount measurement	m3	Sibnefteavtomatika, Russia	DRG.M-10000 Electronic	103	±1.0%	N/A	17.07.08 19.08.09	19.08.11	
		T8	Fuel gas temperature measurement	°C	Metran Industrial Group, Russia	Metran -274-02	509669	±0,5%	N/A	22.07.08 22.07.09	22.07.10	
		P13	Fuel gas pressure measurement	bar	"VEGA" Germany	Vegabar 14	14447569	±0,5%	N/A	04.06.08 04.06.09	04.06.10	

Calibration interval of pressure and temperature sensor is one year.

Calibration interval of gas consumption sensors is once in two years.

(by calibration of DRG.M - 10000 at Ivano-Frankovskstandartmetrologia State-Owned Enterprise, calibration interval has been changed from 3 to 2 years).

JI MONITORING REPORT FORM

Monitoring Report #7 “Utilization of Coal Mine Methane at the Coal Mine named after A.F. Zasyadko” page 25

Meters/ sensors of fuel gas metering system BKT.M – 2

Item No.	Gas to be metered	Symbol on scheme	Metering device designation	Work parameter	Manufacturer	Type	Serial number	Allowed uncertainty	Date of installation	Date of calibration	Date of next calibration	Remarks
M2	Fuel	G2	Fuel gas amount measurement	m3	Sibnefteavtomatika, Russia	DRG.M-10000 Electronic	108	± 1.0%	N/A	15.07.08 15.06.09	15.06.11	Fuel gas metering system BKT.M - 2
		T9	Fuel gas temperature measurement	°C	Metran Industrial Group, Russia	Metran -274-02	510735	± 0.5%	N/A	21.07.08 21.07.09	21.07.10	
		P14	Fuel gas pressure measurement	bar	"VEGA" Germany	Vegabar 14	14568471	± 0.5%	N/A	02.06.08 02.06.09	02.06.10	
M4	Fuel	G4	Fuel gas amount measurement	m3	Sibnefteavtomatika, Russia	DRG.M-10000 Electronic	104	± 1.0%	N/A	15.07.08 15.06.09	15.06.11	
		T10	Fuel gas temperature measurement	°C	Metran Industrial Group, Russia	Metran -274-02	509670	± 0.5%	N/A	21.07.08 21.07.09	21.07.10	
		P15	Fuel gas pressure measurement	bar	"VEGA" Germany	Vegabar 14	14536186	± 0.5%	N/A	02.06.08 02.06.09	02.06.10	
M6	Fuel	G6	Fuel gas amount measurement	m3	Sibnefteavtomatika, Russia	DRG.M-10000 Electronic	097	± 1.0%	N/A	16.07.08 15.06.09	15.06.11	
		T11	Fuel gas temperature measurement	°C	Metran Industrial Group, Russia	Metran -274-02	510733	± 0.5%	N/A	21.07.08 21.07.09	21.07.10	
		P16	Fuel gas pressure measurement	bar	"VEGA" Germany	Vegabar 14	14536368	± 0.5%	N/A	02.06.08 02.06.09	02.06.10	

Calibration interval of pressure and temperature sensor is one year.
Calibration interval of gas consumption sensors is once in two years.

JI MONITORING REPORT FORM

Monitoring Report #7 “Utilization of Coal Mine Methane at the Coal Mine named after A.F. Zasyadko” page 26

Meters/ sensors of fuel gas metering system BKT.M – 3

Item No.	Gas to be metered	Symbol on scheme	Metering device designation	Work parameter	Manufacturer	Type	Serial number	Allowed uncertainty	Date of installation	Date of calibration	Date of next calibration	Remarks
M7	Fuel	G7	Fuel gas amount measurement	m3	Sibnefteavtomatika, Russia	DRG.M-10000 Electronic	098	± 1.0%	N/A	16.07.08 17.07.09	17.07.11	Fuel gas metering system BKT.M - 3
		T12	Fuel gas temperature measurement	°C	Metran Industrial Group, Russia	Metran -274-02	510744	± 0,5%	N/A	21.07.08 21.07.09	21.07.10	
		P17	Fuel gas pressure measurement	bar	"VEGA" Germany	Vegabar 14	14568573	± 0,5%	N/A	03.06.08 03.06.09	03.06.10	
M9	Fuel	G9	Fuel gas amount measurement	m3	Sibnefteavtomatika, Russia	DRG.M-10000 Electronic	099	± 1.0%	N/A	17.07.08 17.07.09	17.07.11	
		T13	Fuel gas temperature measurement	°C	Metran Industrial Group, Russia	Metran -274-02	510742	± 0,5%	N/A	21.07.08 21.07.09	21.07.10	
		P18	Fuel gas pressure measurement	bar	"VEGA" Germany	Vegabar 14	14536304	± 0,5%	N/A	03.06.08 03.06.09	03.06.10	
M11	Fuel	G11	Fuel gas amount measurement	m3	Sibnefteavtomatika, Russia	DRG.M-10000 Electronic	101	± 1.0%	N/A	17.07.08 17.07.09	17.07.11	
		T14	Fuel gas temperature measurement	°C	Metran Industrial Group, Russia	Metran -274-02	510738	± 0,5%	N/A	21.07.08 21.07.09	21.07.10	
		P19	Fuel gas pressure measurement	bar	"VEGA" Germany	Vegabar 14	14568610	± 0,5%	N/A	03.06.08 03.06.09	03.06.10	

Calibration interval of pressure and temperature sensor is one year.
Calibration interval of gas consumption sensors is once in two years.

JI MONITORING REPORT FORM

Monitoring Report #7 "Utilization of Coal Mine Methane at the Coal Mine named after A.F. Zasyadko" page 27

Meters/ sensors of fuel gas metering system BKT.M – 4

Item No.	Gas to be metered	Symbol on scheme	Metering device designation	Work parameter	Manufacturer	Type	Serial number	Allowed uncertainty	Date of installation	Date of calibration	Date of next calibration	Remarks
M8	Fuel	G8	Fuel gas amount measurement	m3	Sibnefteavtomatika, Russia	DRG.M-10000 Electronic	105	± 1.0%	N/A	17.07.08 01.07.09	01.07.11	Fuel gas metering system BKT.M - 4
		T15	Fuel gas temperature measurement	°C	Metran Industrial Group, Russia	Metran -274-02	510754	± 0,5%	N/A	24.07.08 24.07.09	24.07.10	
		P120	Fuel gas pressure measurement	bar	"VEGA" Germany	Vegabar 14	14568589	± 0,5%	N/A	05.06.08 05.06.09	05.06.10	
M10	Fuel	G10	Fuel gas amount measurement	m3	Sibnefteavtomatika, Russia	DRG.M-10000 Electronic	096	± 1.0%	N/A	18.07.08 01.07.09	01.07.11	
		T16	Fuel gas temperature measurement	°C	Metran Industrial Group, Russia	Metran -274-02	510755	± 0,5%	N/A	24.07.08 24.07.09	24.07.10	
		P21	Fuel gas pressure measurement	bar	"VEGA" Germany	Vegabar 14	14536306	± 0,5%	N/A	05.06.08 05.06.09	05.06.10	
M12	Fuel	G12	Fuel gas amount measurement	m3	Sibnefteavtomatika, Russia	DRG.M-10000 Electronic	100	± 1.0%	N/A	15.07.08 01.07.09	01.07.11	
		T17	Fuel gas temperature measurement	°C	Metran Industrial Group, Russia	Metran -274-02	510747	± 0,5%	N/A	24.07.08 24.07.09	24.07.10	
		P22	Fuel gas pressure measurement	bar	"VEGA" Germany	Vegabar 14	14568606	± 0,5%	N/A	05.06.08 05.06.09	05.06.10	

Calibration interval of pressure and temperature sensor is one year.
Calibration interval of gas consumption sensors is once in two years.

JI MONITORING REPORT FORM

The monitoring system for the emission reductions achieved in the course of the project implementation has been integrated in the Zasyadko Coal Mine existing controlling and reporting system. That allows for obtaining reliable and easy verifiable data related to the project performance, ensuring thus the quality and efficiency of the monitoring system.

All source information on performance parameters and calculations have been obtained directly on site and after that reported to the Coal Mine dispatching office. The work parameters of CMM flows as well as heat and power generated will be crosschecked to provide quality and reliability of monitored data. To ensure reliable and non-stop performance of cogeneration plant the inputs of natural gas from the natural gas pipeline are envisaged.

CMM consumption of gas filling stations

Each gas filling station keeps records in the register. Calculations of methane fuelled are executed according to data pressure difference of manometers. Concentration of methane is measured monthly with ABB AO 2040 at CHP and surface well gas analysis. Besides, the concentration of methane is measured locally with an interferometer. Temperature and pressure meters are installed too. The volume of methane is measured by “Universal-2” metering system.

B.1.3. Calibration procedures

For Electricity Meters:

QA/QC (Quality Assurance/ Quality Control) procedures	Body responsible for calibration and certification
Calibration interval of such meters is six years. Calibration procedures for meters are implemented in compliance with calibration methodology developed for “Elster-Metronika” meters, Russia. Manufacturer's warranty-36 months	Manufacturer “Elster-Metronika” LLC, Russia

For Heat Meters

QA/QC (Quality Assurance/ Quality Control) procedures	Body responsible for calibration and certification
Calibration interval of such meters is two years. Calibration procedures for meters are implemented in compliance with calibration methodology developed for ASWEGA meters, Russia. Manufacturer's warranty-18 months	Donetsk Centre for Standardization and Metrology

For CMM meters:

QA/QC (Quality Assurance/ Quality Control) procedures	Body responsible for calibration and certification
Keuter ADM1 Electronic. Calibration interval of such meters is 1 year ¹¹ .	Donetsk Centre for Standardization and Metrology
Gas Analyzer ABB A02040. Calibration interval of such meters is 1 year ¹¹ .	Donetsk Centre for Standardization and Metrology

B.1.4. Involvement of Third Parties:

- Donetsk Centre for Standardization and Metrology¹².
- Ivano-Frankovsk for Standardization and Metrology

B.2. Date collection (accumulated data for the whole monitoring period):

For the operational and management structure of the project see PDD, Figure 5: *Monitoring and quality control system for Vostochnaya and Yakovlevskaya sites*

¹¹ As there is no state regulation for such kind of equipment there was a decision of Ukrainian Centre for Standardization and Metrology for one year calibration period.

¹² All metering equipment shall be calibrated subject to provisions and methods as defined by regulations of this centre.

JI MONITORING REPORT FORM

B.2.1. List of fixed default values:

ID number	Date variable	Source of data	Date unit	Comment
P6 CEFC _{CH4}	Carbon emission factor for combusted methane	2006 IPCC Guidelines for National Greenhouse Gas Inventories. Volume 2: Energy Chapter 4: Fugitive Emissions	tCO ₂ e/tCH ₄	Set at 2.75 tCO ₂ e /tCH ₄ See also table CMM meters
P12 Eff _{CHP}	Efficiency of methane destruction/oxidation in CHP	2006 IPCC Guidelines for National Greenhouse Gas Inventories. Volume 2: Energy Chapter 4: Fugitive Emissions	%	Set at 99.5%
P14 Eff _{GAS}	Overall efficiency of methane destruction/oxidation at the vehicles	2006 IPCC Guidelines for National Greenhouse Gas Inventories. Volume 2: Energy Chapter 4: Fugitive Emissions	%	Set at 98.5%
P15 GWP _{CH4}	Global warming potential of methane	2006 IPCC Guidelines for National Greenhouse Gas Inventories. Volume 2: Energy Chapter 4: Fugitive Emissions	tCO ₂ e/tCH ₄	Set at 21

Table 5: Project variables

ID number	Date variable	Source of data	Date unit	Comment
B13 F _{grid,generated,y}	Emissions factor of electricity of replaced grid electricity production by the project activity in year	See annex 2	tCO ₂ /MWh	See annex 2 PDD See also table “Electrical Meters”
B14 EF _{grid,reduced,y}	Emissions factor of electricity of replaced on-site electricity consumption by the project activity	See annex 2	tCO ₂ /MWh	See annex 2 PDD See also table “Electrical Meters”
B20 EF _{heat,vost}	Emissions factor for heat at Vostochnaya site in the baseline scenario	Boiler efficiency	tCO ₂ /GJ	See annex 2 PDD See also table “Heat Meters”
B22 EF _{heat,yak}	Emissions factor for heat at Yakovlevskaya site in the baseline scenario	Boiler efficiency	tCO ₂ /GJ	See annex 2 PDD See also table “Heat Meters”
B24 EF _{heat,centr}	Emissions factor for heat at Centralnaya site in the baseline scenario	Boiler efficiency	tCO ₂ /GJ	See annex 2 PDD. See also table “Heat Meters”
B25 VFUEL _y	Vehicle fuel provided by the project activity	Fuel Meters	GJ	This value will be calculated based MM _{GAS} of the project scenario multiplied with LHV of methane
B26 EF _v	Emissions factor for vehicle operation replaced by the project activity	2006 IPCC	tCO ₂ /GJ	See annex 2 PDD

Table 6: Baseline Variables

B.2.2. List of variables:

Project emissions variables to be measured:

- MM_{CHP} — Methane measured sent to power plant (tCH₄);
- MM_{GAS} — Methane measured supplied to gas grid for vehicle use (tCH₄).

Baseline emissions variables to be measured:

- GEN_{CHP} — Net electricity generated by the project activity by the CHP plants;
- $El_{Consumed}$ — Net electricity consumed by the mine on-site;
- $HEAT_{consumed, \text{vost}, y}$ — Heat consumed at Vostochnaya site delivered by the project year y

B.2.3. Date concerning GHG emissions by sources of the project activity (referring to paragraph 53(a)):

Year	MM _{GAS} (tCH4)
01.10.2009 – 31.01.2010	438

Table 7: Data to be collected in the project scenario

Year	MM _{CHP} (tCH4)
01.10.2009 – 31.01.2010	9 357

Table 8: Data to be collected in the project scenario

For Methane analysis data refer please to Annex 1 document.

B.2.4. Date concerning GHG emissions by sources of the baseline (referring to paragraph 53(b)):

Year	GEN _{CHP} (MWh)	El _{Cons} (MWh)	HEAT _{cons, \text{vost}, y} (GJ)
01.10.2009 – 31.01.2010	43 975,052	71 656,298	65 532

Table 9: Data collected in the baseline scenario

B.2.5. Date concerning leakage (referring to paragraph 53(c)):

Not Applicable.

B.2.6. Date concerning environmental impacts (referring to paragraph 53(d)):

Not Applicable.

B.3. Date processing and archiving (incl. software used):

All data will be archived in electronic and paper form. (See CO₂ calculation)

B.4. Special event log:

During this monitoring period, no special events occurred.

SECTION C. Quality assurance and quality control measures:**C.1. Documented procedures and management plan:****C.1.1. Roles and responsibilities:**

The general project management is implemented by the Deputy General Director of the Zasyadko Coal Mine through supervising and coordinating activities of his subordinates, such as deputy director on surface degasification, chief power engineer, chief heating engineer, and heads of safety engineering departments. On-site day-to-day management is implemented by the manager of cogeneration station who directs two shift operators responsible for cogeneration modules and gas treatment plant performance. An on-duty electrician works at the plant. During the daytime a group of mechanics who are responsible for preventive measures and maintenance of all technological equipment, metering instruments as well as of automation tools and telemechanics are present on-site. On-line information transmitted directly to the head of the shift into the Coal Mine Central Dispatching Office. The cogeneration plant is in 24 hours operation. Three shifts by eight hours have been introduced.

At the main objects the responsibilities are as follows:

- VPS operator controls data before VPS and after VPS (at the gas treatment plant) including CMM and natural gas flow parameters;
- Two cogeneration plant operators control data at the inlets of cogeneration modules (at the gas treatment plant), work process parameters, and heat and power output. Substation operator controls data on electric power amounts dispatched to and supplied from the grid as well as in-house electricity consumption.

All the information will be channelled to the workstation of the Coal Mine central dispatching office and on-line monitored by the head of the shift that will be responsible for calculation of the CO₂ equivalent emission reductions. Such calculations are made on a monthly basis. The general supervision of the monitoring system is executed by Zasyadko Coal Mine administration under the existing control and reporting system.

C.1.2. Trainings:

GE Jenbacher (Austria) has delivered CHP main equipment being CHP units. As specified in the contract, training of staff that operates these units was performed in Austria. GE Jenbacher technicians have performed extra training during installation and commissioning works. Employees in charge for monitoring control have also passed training during installation of the said system.

Extra training is performed during equipment operation. CHP and VPS staff training program, as well as emergency training, are submitted as separate document represented as EMISSION MONITORING MANUAL FOR Mine named after A.F.Zasyadko (Manual 2), which also includes structural diagram of technical maintenance provision and state calibration of meters of automated metering system.

C.2. Involvement of Third Parties:

The Donetsk Centre for Standardization and Metrology and Ivano-Frankovsk Centre for Standardization and Metrology are Third Parties involved.

C.3. Internal audits and control measures:

Introduction of a modern computerized control system allows for efficient on-line monitoring and reviewing work process performance at the Zasyadko Central Dispatching office every fifteen minutes. (Especially for fuel and ignition gas consumption, their parameters and electricity and heat generated data can be obtained every 10 seconds if requested). Any considerable deviation of monitored data from given work parameters will be promptly noticed and source of such deviation will be easily identified. In turn this enables the head of shift to efficiently coordinate adjustment actions of his shift subordinates including on-duty technical staff that will improve work process and eliminate such deviations. This system improved operational process and eliminated lacks in control of CHP gas consumption.

C.4. Troubleshooting procedures¹³:

See C .1.2

In case of a break down of CMM supply system (either of whole system or separate feeding pipe) methane-air mixture will be urgently released into the atmosphere through the emergency gas vent stack. The shut-off valves will automatically close CMM supply pipes, natural gas will be fed into gas treatment plant and consequently into the inlets of engines and into pre-chambers. As the main gas record blocks (figure 3) are after the venting stack, only combusted CMM will be accounted for.

¹³ At CHP, the equipment of the same type is installed, for substitution of main equipment for short period in case of breakdown or calibration- electricity and heat meters, CMM metering equipment, pressure, temperature sensors, etc. These devices, being connected to or installed, are able to transfer all data to monitoring and control computer system. Equipment is also calibrated in certain period by Centre for Standardization and Metrology, and Ivano-Frankovsk Centre for Standardization and Metrology.

SECTION D. Calculation of GHG emission reductions

D.1. Project emissions

The project emissions of the project are given by the following equation. The emissions for the use to capture and use methane PE_{ME} have not been taken as the energy use for the vacuum pumps are outside the project boundary (see section B.3 of PDD) and the annual electricity consumption of the gas filling station results in emission below 2,000 tCO₂e.

$$PE_y = PE_{MD} + PE_{UM}, \quad (5.)$$

where:

- PE_y - project emission in year y (tCO₂e)
- PE_{MD} - project emissions from methane destroyed (tCO₂e);
- PE_{UM} - project emissions from un-combusted methane (tCO₂e)

The project emissions from methane destroyed

The project emissions from methane destroyed are given by the equation below. Methane will be destroyed in CHPs and as the CHP produces both electricity and heat at one source, MD_{ELEC} and MD_{HEAT} are combined into MD_{CHP} . No flaring takes place so $MD_{FL} = 0$.

$$PE_{MD} = (MD_{CHP} + MD_{GAS}) \times (CEF_{CH_4} + r \times CEF_{NMHC}), \quad (6.)$$

At $r = PC_{NMHC} / PC_{CH_4}$

where:

- PE_{MD} - project emissions from CMM destroyed (tCO₂e);
- MD_{CHP} - methane destroyed in the CHPs (tCH₄);
- MD_{GAS} - methane destroyed by the vehicles supplied by the new gas filling stations (tCH₄);
- CEF_{CH_4} - carbon emission factor for combusted methane (2.75 tCO₂e/tCH₄).
- ¹⁴ CEF_{NMHC} - carbon emission factor for combusted non-methane hydrocarbons (the concentration varies, and, therefore, to be obtained through periodical analysis of captured methane) (tCO₂e/tNMHC);
- r - relative proportion of NMHC compared with methane;
- PC_{CH_4} - concentration (in mass) of methane in extracted gas (%);
- PC_{NMHC} - concentration (in mass) of NMHC in extracted gas (%).

The relative proportion of NMHC was monitored, and their concentration is less than 1%. Therefore, NMHC were excluded from calculation. So:

$$PE_{MD} = (MD_{CHP} + MD_{GAS}) \times CEF_{CH_4}, \quad (7.)$$

Emissions of CHPs

The emissions of CHPs are given by following equations:

$$MD_{CHP} = MM_{CHP} \times Eff_{CHP}, \quad (8.)$$

where :

- MD_{CHP} - methane destroyed at heat and power generation (tCH₄);
- MM_{CHP} - measured methane sent to CHP (tCH₄);
- Eff_{CHP} - efficiency of methane destruction/ oxidation at CHP (taken as 99.5% of IPCC).

¹⁴ At the moment non-methane hydrocarbons are not included in calculation because of concentration less than 1%. Their concentration is checked quarterly with laboratory analyses. In case of concentration more than 1% it will be considered in calculations.

D.2. Emissions of gas utilization

Some methane will be supplied to the gas filling stations that will supply the vehicles. The emissions as a result are given by the following equations.

$$MD_{GAS} = MM_{GAS} \times Eff_{GAS} , \quad (9.)$$

where:

- MD_{GAS} - methane destroyed by the vehicles supplied by the gas filling stations (tCH4);
- MM_{GAS} - methane measured supplied to vehicles supplied by the gas filling stations (τCH4);
- Eff_{GAS} - overall efficiency of methane destruction/ oxidation through gas grid to various combustion end uses, combining fugitive emissions from the gas grid and combustion efficiency at end user (taken as 98.5% of IPCC).

Emissions from un-combusted methane.

$$PE_{UM} = GWP_{CH_4} \times (MM_{CHP} \times (1 - Eff_{CHP}) + MM_{GAS} \times (1 - Eff_{GAS})) , \quad (10.)$$

where:

- PE_{UM} - project emissions from un-combusted methane (tCO2e);
- GWP_{CH_4} - global warming potential of methane (21 tCO2e/tCH4);
- MM_{CHP} - methane measured sent to use at CHP (tCH4);
- Eff_{CHP} - efficiency of methane destruction in CHP (taken as 99.5% of IPCC);
- MM_{GAS} - methane measured sent to use for gas filling (tCH4);
- Eff_{GAS} - efficiency of methane destruction in vehicle usage (taken as 98.5% of IPCC).

D.3.1. Project emissions:

Year	[τCO2e/year]	
Total: 01.10.2009 – 31.01.2010	[τCO2e]	27 911

Table 10: project emissions

D.3.2. Baseline emissions:

The baseline emissions are given by following equation. There is no destruction of methane in baseline scenario at the mine, $BE_{MD,y} = 0$

$$BE_y = BE_{MR,y} + BE_{Use,y} , \quad (11.)$$

where:

- BE_y - baseline emissions in year y (tCO2e);
- $BE_{MR,y}$ - baseline emissions from release of methane into the atmosphere that are avoided by the project activity in year y (tCO2e);
- $BE_{Use,y}$ - baseline emissions from the production of power, heat replaced by the project activity in year y (tCO2e).

Baseline emissions of methane avoided by the project activity.

As there is neither CBM (coal bed methane) nor CMM (coal mine methane) at the mine, the emissions equal the amount of post-mining CMM captured in the project activity that is sent to CHP and the gas filling stations.

$$BE_{MR,y} = GWP_{CH_4} \times (CMM_{PJ,CHP,y} + CMM_{PJ,GAS,y}) , \quad (12.)$$

where :

- $CMM_{PJ,CHP,y}$ - post-mining CMM captured, sent to and destroyed in the CHP in the project activity in year y (tCH4);

- $CMM_{PJ,GAS,y}$ - pre-mining CMM captured, supplied to the net gas filling stations and destroyed by the vehicles in the project activity in year y (tCH4);
- GWP_{CH4} - global warming potential for methane (=21 tCO₂e/tCH4).

Baseline emissions of replacement of electricity, heat and vehicle fuel by the project activity

As there is only post-mining CMM involved the baseline emissions are given in the following equation:

$$B_{Use,y} = BE_{Use,el,y} + BE_{Use,heat,y} + BE_{Use,gas,y} \quad (13.)$$

where:

- $BE_{Use,y}$ - potential total baseline emissions from the production of power, heat, and vehicle fuels replaced by the project activity in year y (tCO₂);
- $BE_{Use,el,y}$ - total baseline emissions from the production of power, replaced by the project activity in year y (tCO₂);
- $BE_{Use,heat,y}$ - total baseline emissions from the production of heat, replaced by the project activity in year y (tCO₂);
- $BE_{Use,gas,y}$ - total baseline emissions of vehicle fuels, replaced by the project activity in year y (tCO₂e).

Baseline emissions of replacement of electricity (power)

Baseline emissions of replacement of electricity by the project activity are given by two equations. When the amount of electricity generated in a year by the project activity is less than the total amount of electricity consumed by mine, the baseline emissions are as follows:

$$BE_{Use,el,y} = GEN_{CHP,y} \times EF_{grid,reduced,y} \quad (14.)$$

When the amount of electricity generated in year by the project activity is more than total amount of electricity consumed by mine (i.e. electricity will be supplied to the grid), the baseline emissions are as follows:

$$BE_{Use,el,y} = (GEN_{CHP,y} - EL_{cons,y}) \times EF_{grid,produced,y} + EL_{CONS,y} \times EF_{grid,reduced,y} \quad (15.)$$

where:

- $BE_{Use,el,y}$ - total baseline emissions from the production of power, replaced by the project activity in year y (tCO₂);
- $GEN_{CHP,y}$ - net electricity generated by the project activity of the CHP plants (MWh);
- $EF_{grid,produced,y}$ - emission factor of electricity of replaced grid electricity production by the project activity in year y (tCO₂/ MWh);
- $EL_{CONS,y}$ - net electricity consumed by mine on-site in year y (MWh);
- $EF_{grid,reduced,y}$ - emissions factor for electricity of replaced on-site electricity consumption by the project activity (tCO₂/MWh)

For this monitoring period, the net electricity generated is less than net electricity consumed (see section B.1.2). Therefore, formula 14 was used.

Baseline emissions of replacement of heat

Heat produced by CHP supplies Vostochnaya site. Baseline emissions are given by following equation.

$$BE_{Use,Heat,y} = HEAT_{cons,vost,y} \times EF_{Heat,vost} \quad (16.)$$

where:

- $HEAT_{cons,vost,y}$ - heat consumed at Vostochnaya site, supplied by the project activity in year y (GJ);
- $EF_{Heat,vost}$ - emission factor for heat at Vostochnaya site in the baseline scenario (tCO₂/GJ).

Baseline emissions of replacement of vehicle fuels

The baseline emissions of the replacement of vehicle fuels by the project activity are given by the following equation.

$$BE_{Use.Gas} = VFUEL_y \times EF_v \tag{17.}$$

where:

- $VFUEL_y$ - vehicle fuel provided by the project activity (GJ);
- EF_v - emission factor for vehicle operation replaced by the project activity (tCO2/GJ).

Emission factor for vehicle fuels

Emission factor for vehicle fuels is given by following equation.

$$EF_v = \frac{EF_{cos\lambda}}{Eff_v} \times \frac{44}{12} \times \frac{1TJ}{1000 GJ} \tag{18.}$$

where:

- EF_v - emission factor for vehicle fuels replaced by the project activity (tCO2/GJ);
- $EF_{cos\lambda}$ - emission factors for CO₂ foe fuels used for vehicle operation replaced by the project activity (tCO2/GJ);
- Eff_v - efficiency of vehicle motors (%);
- $44/12$ - carbon to Carbon Dioxide conversion factor;
- $1/1000$ - TJ to GJ conversion factor.

Year	[tCO2e/year]	
Total: 01.10.2009 – 31.01.2010	[tCO2e]	250 810

Table 11: Baseline emissions

D.3.3. Leakages:

Not Applicable

D.3.4. Emission reduction summary in monitoring period:

Year	[tCO2e/year]	
Total: 01.10.2009 – 31.01.2010	[tCO2e]	222 899

Table 12: Emission reductions

JI MONITORING REPORT FORM

Gas sample analysis – 4th quarter 2009

APPROVED

P.S.Pashkovskiy
First Director Deputy, Science
Activity, Dr. Sc. < signature >
Seal
The 04^h of December, 2009

**Percentage of matters in samples of gas taken on 28.11.09
at Lease Enterprise Mine named after A.F.Zasyadko**

Main Components	Sampling Point		
	Vacuum Pump Station-1		Vacuum Pump Station -2
	First group	Second group	Second group
	Concentration, %		Concentration, %
Methane CH ₄	14,9	14,9	35,3
Ethan C ₂ H ₆	0,06	0,06	0,4
Propane C ₃ H ₈	0,0018	0,0018	0,02
Butane C ₄ H ₁₀	0,006	0,006	0,004
Pentane C ₅ H ₁₂	n/a	n/a	n/a
Hexane C ₆ H ₁₄	n/a	n/a	n/a
Carbon Oxide CO	n/a	n/a	0,0008
Hydrogen H ₂	n/a	n/a	0,06
Carbon Dioxide CO ₂	0,07	0,07	0,04
Nitrogen N ₂	67,6	67,6	51,3
Oxygen O ₂	13,9	13,9	12,3
Argon Ar	0,67	0,67	0,53
Micro-Components	mg/Nm³		
Ammonia NH ₃	0,002	0,002	n/a
Chlorine Cl ₂	n/a	n/a	n/a
Fluorine F ₂	n/a	n/a	n/a
hydrogen sulphide H ₂ S	0,008	0,008	n/a
Sulfide dioxide SO ₂	n/a	n/a	n/a
Dust, mg/m ³	<1	n/a	<1
Moisture, mg/m ³	2010	2010	2590

VPS 1 includes first and second set combined in common degasification line.

* re-calculated per dry gas

Analysis person in charge

signed

B.I. Koshovskiy

JI MONITORING REPORT FORM

APPROVED

P.S.Pashkovskiy
 First Director Deputy, Science
 Activity, Dr. Sc. < signature >
 Seal
 The 04^h of December, 2009

**Percentage of matters in fuel gas and ignition gas samples taken on 28.11.09
 at Lease Enterprise Mine named after A.F.Zasyadko**

Main components	Fuel Gas, Concentration, %	Ignition Gas, Concentration, %
Methane CH ₄	32,6	96,8
Ethan C ₂ H ₆	0,16	0,6
Propane C ₃ H ₈	0,05	0,06
Butane C ₄ H ₁₀	0,007	0,003
Pentane C ₅ H ₁₂	0,005	0,009
Hexane C ₆ H ₁₄	0,0004	0,0004
Carbon Oxide CO	0,0004	0,005
Hydrogen H ₂	0,05	0,03
Carbon Dioxide CO ₂	0,07	n/a
Nitrogen N ₂	52,1	1,3
Oxygen O ₂	13,1	0,29
Argon Ar	0,37	n/a
Micro-Components	mg/Nm³	
Ammonia NH ₃	n/a	n/a
Chlorine Cl ₂	n/a	n/a
Fluorine F ₂	n/a	n/a
Hydrogen sulphide H ₂ S	0,04	n/a
Sulfide dioxide SO ₂	n/a	n/a
Dust, mg/m ³	<1	2
Moisture, mg/m ³	2260	1780

* re-calculated per dry gas

Analysis person in charge

signed

B.I. Koshovskiy