

JI MONITORING REPORT

Monitoring Report #5 "Utilization of Coal Mine Methane at the Coal Mine named after A.F. Zasyadko" page 1

JI MONITORING REPORT

FIFTH PERIODIC MONITORING REPORT THIRD JI MONITORING REPORT

**Version 1.2
08 January 2009**

CONTENTS

- A. General project activity and monitoring information
- B. Key monitoring activities
- C. Quality assurance and quality control measures
- D. Calculation of GHG emission reductions

JI MONITORING REPORT

Monitoring Report #5 "Utilization of Coal Mine Methane at the Coal Mine named after A.F. Zasyadko" page 2

Initial remark (referring to Decision 17/CP.7, Annex H, paragraph 54, 56, 58 and 60)

54. A monitoring plan for a proposed project activity shall be based on a previously approved monitoring methodology or a new methodology, in accordance with paragraphs 37 and 38 above, that:

(a) Is determined by the designated operational entity as appropriate to the circumstances of the proposed project activity and has been successfully applied elsewhere;

(b) Reflects good monitoring practice appropriate to the type of project activity.

56. Project participants shall implement the monitoring plan contained in the registered project design document.

58. The implementation of the registered monitoring plan and its revisions, as applicable, shall be a condition for verification, certification and the issuance of CERs.

60. The project participants shall provide to the designated operational entity, contracted by the project participants to perform the verification, a monitoring report in accordance with the registered monitoring plan set out in paragraph 53 above for the purpose of verification and certification.

SECTION A. General Project activity information

A.1 Title of the project activity:

“Utilization of Coal Mine Methane at the Coal Mine named after A.F. Zasyadko”

A.2. JI registration number:

JI 0035

A.3. Short description of the project activity:

According to data of the mine the following amount of methane was utilized during last three months of the year 2008:

For electricity (and heat), m ³ (fuel gas)	8,655,667
For electricity (and heat), m ³ (ignition gas)	342,550
For AGFCP, m ³	481,042
Total m ³	9,479,259

Table 1: Amount of methane utilized during monitoring period.

A.4. Monitoring period:

- Monitoring period starting date: 1/10/2008;
- Monitoring period closing date: 31/12/2008.¹

A.5. Methodology applied to the project activity (incl. version number):

A.5.1. Baseline methodology: The approved consolidated methodology ACM0008/Version 03 “*Consolidated baseline methodology for coal bed methane and coal mine methane capture and use for power (electrical or motive) and heat and/or destruction by flaring*”) has been used to identify the baseline scenario of the proposed JI project. This methodology also refers to the “Tool for calculation of emission factor for electricity systems”, the latest version of the “Tool for the demonstration and assessment of additionality” and the latest version of the “Tool to determine project emissions from flaring gases containing Methane”.

A.5.2. Monitoring methodology: The approved consolidated methodology ACM0008/Version 03 “*Consolidated monitoring methodology for coal bed methane and coal mine methane capture and use for power (electrical or motive) and heat and/or destruction by flaring*”) has been used to monitor the proposed JI project.

¹ Both days were included. Monitoring period includes time from 00:00 01/10/08 up to 24:00 31/12/08.

JI MONITORING REPORT

Monitoring Report #5 "Utilization of Coal Mine Methane at the Coal Mine named after A.F. Zasyadko" page 4

A.6. Status of implementation including time table for major project parts:

Activity	Date
Commissioning of blocks (#1,#2) at gas filling compressor stations at Vostochnaya site	March 2004
Commissioning of new block #3 at gas filling compressor station at Vostochnaya site	March 2005
Commissioning of the 1 st CHP modules at Vostochnaya site	January 2006
Commissioning of the 12 th CHP modules at Vostochnaya site	April 2006
Shut-down of boilers at Vostochnaya site	September 2006
Construction of vacuum pump station N 4 at Grigoryevskaya shaft with six vacuum pumps VVN-150 and build up 3 pipe lines	March 2007
Commissioning of the twelfth power unit on Yakovlevskaya industrial site	July- December 2009
Construction of heat supply unit on Central industrial site; Shut down of boiler houses on Centralnaya industrial site	May 2008
Construction and laying of heating main from Centralnaya site to municipal boiler houses	September 2008
Construction of heating main from Yakovlevskaya to Vostochnaya site. Construction of main Heat Substation. Shutdown boilers at Yakovlevskaya.	October 2009

Table 2: Status of implementation (according to PDD version 4.4)

A.7. Intended deviations or revisions to the registered PDD:

Activity	Date
Commissioning of the power units on Yakovlevskaya industrial site	First Quarter 2010
Construction of heat supply unit on Central industrial site; Shut down of boiler houses on Centralnaya industrial site	Second Quarter 2010
Construction and laying of heating main from Centralnaya site to municipal boiler houses	Second Quarter 2010
Construction of heating main from Yakovlevskaya to Vostochnaya site. Construction of main Heat Substation. Shutdown boilers at Yakovlevskaya.	Second Quarter 2010
Construction of heating main from Vostochnaya to Centralnaya industrial site	Third quarter 2010

Table 3: Status of implementation

JI MONITORING REPORT

Monitoring Report #5 "Utilization of Coal Mine Methane at the Coal Mine named after A.F. Zasyadko" page 5

A.8. Intended deviations or revisions to the registered monitoring plan (Decision 17/CP.7, Annex H, paragraph 57 to be considered):

Compared to the monitoring plan, as described in the PDD version 4.4 which determination was made final on the 24th of August 2008, some meters were changed and added to improve the robustness of the monitored parameters. All these meters were calibrated (see below). The parameters were not changed nor where the formulae altered.

The following meters were added/changed effective 1 January 2008:

The primary and secondary meters were swapped as the metering at the CHP units was upgraded and improved. In addition new metering system blocks for methane of high concentration were installed:

- The Universal 1 meter for ignition methane at the CHP facility site instead of Gn6 with its sensors
- The Universal 2 meter for fuel methane at AGFCS in addition to equipment of gas filling blocks
- BKTM metering systems for fuel methane instead of Keuter, ADM Electronic

For detailed description of scheme and operation of equipment refer please to section B.

A.9. Changes since last verification:

There are no deviations since last verification which took place over the period 1/07/2008 – 30/09/2008.

A.10. Person(s) responsible for the preparation and submission of the monitoring report:

Lease enterprise "Coal Mine named after A.F. Zasyadko"

- Boris Bokiy, Deputy General Director

Global Carbon B.V.

- Lennard de Klerk, Director
- Valeriy Sade, Consultant

JI MONITORING REPORT

Monitoring Report #5 “Utilization of Coal Mine Methane at the Coal Mine named after A.F. Zasyadko” page 6

SECTION B. Key monitoring activities according to the monitoring plan² for the monitoring period stated in A.4. (Referring to Decision 17/CP.7, Annex H, paragraph 53 (a) – (d) on data collection and archiving)³

The control and monitoring system can be divided into an electrical part, a heat part and a gas part⁴.

Electrical measurements

There are no changes since last monitoring period.

Heat measurements

There are no changes since last monitoring period⁵.

Measurement of CMM consumption

There are no changes since last monitoring period.

B.1. Monitoring equipment types

1. Electricity meters “Elster-Metronika”
2. Heat meter SA-94/2 M
3. Gas Analyzer ABB A02040 (for fuel and ignition methane)
4. DBT⁶ equipment.(for fuel and ignition methane)
5. DRGM flow meters⁷ (for fuel methane) as a part of BKTM metering systems.
6. Metering system “Universal”

² Monitoring manual will be available at the site during verification.

³ Electricity and heart generation as well as methane consumption are calculated at an hourly basis by a computer system.

⁴ All calibration information for metering equipment will be submitted as separate documents.

⁵ There were no changes in the heat distributing over the Mine sites since last monitoring and no heat was supplied to the DH network yet (planned later). Parameters B15, B17, B18, B21 and B23 are therefore not measured and monitored in this monitoring period. All changes will be after commissioning of Yakovlevskaya CHP facility and construction main heat distribution substation at Centralnaya site.

⁶ DBT system works for Vostochnaya CHP plant since the beginning of year 2006. Sensors for methane concentration have been used to provide data for computer monitoring system. All sensors have now Ukrainian Metrology Certificates.

⁷ Primary meters

JI MONITORING REPORT

B.1.2. Table providing information on the equipment used (incl. manufacturer, type, serial number, date of installation, date of last calibration, information to specific uncertainty, need for changes and replacements)⁸:

Electrical measurements

There are no changes since last monitoring period. For the purpose of monitoring the emission reductions the following parameters are to be measured:

1. Net electricity generation of both CHP systems⁹;
2. Net electricity consumption of the mine (all four production sites);

Electrical Meters

Measuring instrument	Work parameter kWh, kVar	Manufacturer	Type	Serial Number	Uncertainty level of data and accuracy	Date of installation	Data 1.10.2008	Data 31.12.2008	Difference	Date of last calibr.	Date of next calibr.	Remarks ¹⁰
Electricity meter at CHP system (6 kV) Wireway	Net electricity generated by CHP system. P,Q	“Elster-Metronika” Russia	Electronic	01116374	±0.2% ¹¹	N/A	4943.2106	5327.0361	383.8255	14.05.2005	2nd Quarter 2011	Double side. Cubicle #A21

⁸ For all technical data refer please to Monitoring Report for year 2004-2006.

⁹ At the moment only electricity generated by CHP facility Vostochnaya is measured. The commercial amount of net electricity supplied to consumer is reflected in statement submitted by Chief Energy Manager of the Mine.

¹⁰ The Meters in cubicles from A2 to #16 are installed at CHP facility used as secondary meters for cross-checking at CHP facility.

¹¹ The measurement range (accuracy) is 80...120 V;0...5 (10-max) A.

JI MONITORING REPORT

Monitoring Report #5 “Utilization of Coal Mine Methane at the Coal Mine named after A.F. Zasyadko”

page 8

Measuring instrument	Work parameter kWh, kVar	Manufacturer	Type	Serial Number	Uncertainty level of data and accuracy	Date of installation	Data 1.10.2008	Data 31.12.2008	Difference	Date of last calibr.	Date of next calibr.	Remarks
Electricity meter at CHP system (6 kV) Wireway	Net electricity generated by CHP system. P,Q	“Elster-Metronika” Russia	Electronic	01116376	±0.2%	N/A	5012.7242	5432.8103	420.0861	14.05.2005	2nd quarter 2011	Double side. Cubicle #A22
Electricity ¹² meter at CHP system (6 kV) Auxiliary transformer	Auxiliary electricity generated by CHP system	“Elster-Metronika” Russia	Electronic	01103251	±0.2%	N/A	2611.6839	2804.6062	192.9223	03.09.2004	3rd quarter 2010	Cubicle #1
Electricity meter at CHP system (6 kV) Auxiliary transformer	Auxiliary electricity generated by CHP system	“Elster-Metronika” Russia	Electronic	01103208	±0.2%	N/A	2781.0035	2977.8563	196.8528	03.09.2004	3rd quarter 2010	Cubicle #2
Electricity meters at individual CHP modules (6 kV) #1	Gross electricity generated by CHP system P,Q	“Elster-Metronika” Russia	Electronic	01117846	±0.2%	N/A	4868.7724	5354.4972	348.8027	16.06.2005	2nd quarter 2011	Double side. Cubicle #5
Electricity meters at individual CHP modules (6 kV) #3	Gross electricity generated by CHP system P,Q	“Elster-Metronika” Russia	Electronic	01117849	±0.2%	N/A	5812.6942	6366.4029	553.7087	16.06.2005	2nd quarter 2011	Double side. Cubicle #7

¹² Auxiliary transformer meters are located at distribution board at CHP facility.

JI MONITORING REPORT

Monitoring Report #5 “Utilization of Coal Mine Methane at the Coal Mine named after A.F. Zasyadko”

page 9

Measuring instrument	Work parameter kWh, kVar	Manufacturer	Type	Serial Number	Uncertainty level of data and accuracy	Date of installation	Data 1.10.2008	Data 31.12.2008	Difference	Date of last calibr.	Date of next calibr.	Remarks
Electricity meters at individual CHP modules (6 kV) #5	Gross electricity generated by CHP system P,Q	“Elster-Metronika” Russia	Electronic	01117851	±0.2%	N/A	6347.7334	7009.7556	662.0222	16.06.2005	2nd quarter 2011	Double side. Cubicle #9
Electricity meters at individual CHP modules (6 kV) #7	Gross electricity generated by CHP system P,Q	“Elster-Metronika” Russia	Electronic	01117852	±0.2%	N/A	6669.0870	7076.2119	407.1249	16.06.2005	2nd quarter 2011	Double side. Cubicle #11
Electricity meters at individual CHP modules (6 kV) #9	Gross electricity generated by CHP system P,Q	“Elster-Metronika” Russia	Electronic	01117855	±0.2%	N/A	6874.1563	7586.0212	711.8649	16.06.2005	2nd quarter 2011	Double side. Cubicle #13
Electricity meters at individual CHP modules (6 kV) #11	Gross electricity generated by CHP system P,Q	“Elster-Metronika” Russia	Electronic	01117856	±0.2%	N/A	6622.8262	7062.2035	439.3773	16.06.2005	2nd quarter 2011	Double side. Cubicle #15
Electricity meters at individual CHP modules (6 kV) #2	Gross electricity generated by CHP system P,Q	“Elster-Metronika” Russia	Electronic	01117848	±0.2%	N/A	6788.1941	7612.8447	824.6506	16.06.2005	2nd quarter 2011	Double side. Cubicle #6

JI MONITORING REPORT

Monitoring Report #5 “Utilization of Coal Mine Methane at the Coal Mine named after A.F. Zasyadko”

page 10

Measuring instrument	Work parameter kWh, kVar	Manufacturer	Type	Serial Number	Uncertainty level of data and accuracy	Date of installation	Data 1.10.2008	Data 31.12.2008	Difference	Date of last calibr.	Date of next calibr.	Remarks
Electricity meters at individual CHP modules (6 kV) #4	Gross electricity generated by CHP system P,Q	“Elster-Metronika” Russia	Electronic	01117645	±0.2%	N/A	4865.2849	4865.2849	0	10.08.2005	3rd quarter 2011	Double side. Cubicle #8
Electricity meters at individual CHP modules (6 kV) #6	Gross electricity generated by CHP system P,Q	“Elster-Metronika” Russia	Electronic	01122650	±0.2%	N/A	5794.0164	6507.4503	713.4339	10.08.2005	3rd quarter 2011	Double side. Cubicle #10
Electricity meters at individual CHP modules (6 kV) #8	Gross electricity generated by CHP system P,Q	“Elster-Metronika” Russia	Electronic	01117845	±0.2%	N/A	7479.1741	8179.9092	700.7351	16.06.2005	2nd quarter 2011	Double side. Cubicle #12
Electricity meters at individual CHP modules (6 kV) #10	Gross electricity generated by CHP system P,Q	“Elster-Metronika” Russia	Electronic	01132765	±0.2%	N/A	6823.3919	7574.2747	750.8828	09.02.2006	1st quarter 2012	Double side. Cubicle #14

JI MONITORING REPORT

Monitoring Report #5 “Utilization of Coal Mine Methane at the Coal Mine named after A.F. Zasyadko”

page 11

Measuring instrument	Work parameter kWh, kVar	Manufacturer	Type	Serial Number	Uncertainty level of data and accuracy	Date of installation	Data 1.10. 2008	Data 31.12.2008	Difference	Date of last calibr.	Date of next calibr.	Remarks
Electricity meters at individual CHP modules (6 kV) #12	Gross electricity generated by CHP system P,Q	“Elster-Metronika” Russia	Electronic	01132766	±0.2%	N/A	6101.1777	6101.1777	0	09.02.2006	1st quarter 2012	Double side. Cubicle #16
Commercial electricity meter at 110 kV	Power consumption from or supply to the Ukrainian grid	“Elster-Metronika” Russia	Electronic	1116378	±0.2%	N/A	296.6471	303.7315	7.0844	N/A Belongs to supply company	N/A	Substation 110kV T1
Commercial electricity meter at 110 kV	Power consumption from or supply to the Ukrainian grid	“Elster-Metronika” Russia	Electronic	1116380	±0.2%	N/A	306.3680	308.5064	2.1384	N/A Belongs to supply company	N/A	Substation 110kV T2

Calibration interval for electricity meters is six years.

As it is impossible to use meters data directly to check electricity generated we have to take in account special coefficients which is appears from multiplying of coefficients transformation for current and voltage transformers connected to each meter. Their data are presented in table below.

JI MONITORING REPORT

Monitoring Report #5 “Utilization of Coal Mine Methane at the Coal Mine named after A.F. Zasyadko” page 12

Measuring instrument	Work parameter kWh, kVar	Type	Serial Number	Current transformer	Voltage transformer	Coefficient for calculations	Electricity Amount KW
Electricity meter at CHP system (6 kV) Wireway	Net electricity generated by CHP system. P,Q	Electronic	01116374	3000/5	6300/100	37800	14,508.604
Electricity meter at CHP system (6 kV) Wireway	Net electricity generated by CHP system. P,Q	Electronic	01116376	3000/5	6300/100	37800	15,879.255
Electricity meter at CHP system (6 kV) Auxiliary transformer	Auxiliary electricity generated by CHP system	Electronic	01103251	200/5	6300/100	2520	486.164
Electricity meter at CHP system (6 kV) Auxiliary transformer	Auxiliary electricity generated by CHP system	Electronic	01103208	200/5	6300/100	2520	496.069
Electricity meters at individual CHP modules (6 kV) #1	Gross electricity generated by CHP system P,Q	Electronic	01117846	400/5	6300/100	5040	1,757.966
Electricity meters at individual CHP modules (6 kV) #3	Gross electricity generated by CHP system P,Q	Electronic	01117849	400/5	6300/100	5040	2,790.692
Electricity meters at individual CHP modules (6 kV) #5	Gross electricity generated by CHP system P,Q	Electronic	01117851	400/5	6300/100	5040	3,336.592
Electricity meters at individual CHP modules (6 kV) #7	Gross electricity generated by CHP system P,Q	Electronic	01117852	400/5	6300/100	5040	2,051.909
Electricity meters at individual CHP modules (6 kV) #9	Gross electricity generated by CHP system P,Q	Electronic	01117855	400/5	6300/100	5040	3,587.799
Electricity meters at individual CHP modules (6 kV) #11	Gross electricity generated by CHP system P,Q	Electronic	01117856	400/5	6300/100	5040	2,214.462

JI MONITORING REPORT

Monitoring Report #5 “Utilization of Coal Mine Methane at the Coal Mine named after A.F. Zasyadko” page 13

Measuring instrument	Work parameter kWh, kVar	Type	Serial Number	Current transformer	Voltage transformer	Coefficient for calculations	Electricity Amount KW
Electricity meters at individual CHP modules (6 kV) #2	Gross electricity generated by CHP system P,Q	Electronic	1117848	400/5	6300/100	5040	4,156.239
Electricity meters at individual CHP modules (6 kV) #4	Gross electricity generated by CHP system P,Q	Electronic	01122645	400/5	6300/100	5040	0
Electricity meters at individual CHP modules (6 kV) #6	Gross electricity generated by CHP system P,Q	Electronic	01122650	400/5	6300/100	5040	3,595.707
Electricity meters at individual CHP modules (6 kV) #8	Gross electricity generated by CHP system P,Q	Electronic	01117845	400/5	6300/100	5040	3,531.705
Electricity meters at individual CHP modules (6 kV) #10	Gross electricity generated by CHP system P,Q	Electronic	01132765	400/5	6300/100	5040	3,784.449
Electricity meters at individual CHP modules (6 kV) #12	Gross electricity generated by CHP system P,Q	Electronic	01132766	400/5	6300/100	5040	0
Commercial electricity meter at 110 kV	Power consumption from or supply to the Ukrainian grid	Electronic	01116378	1000/5	110000/100	220000	15,585.680
Commercial electricity meter at 110 kV	Power consumption from or supply to the Ukrainian grid	Electronic	01116380	1000/5	110000/100	220000	47,034.000

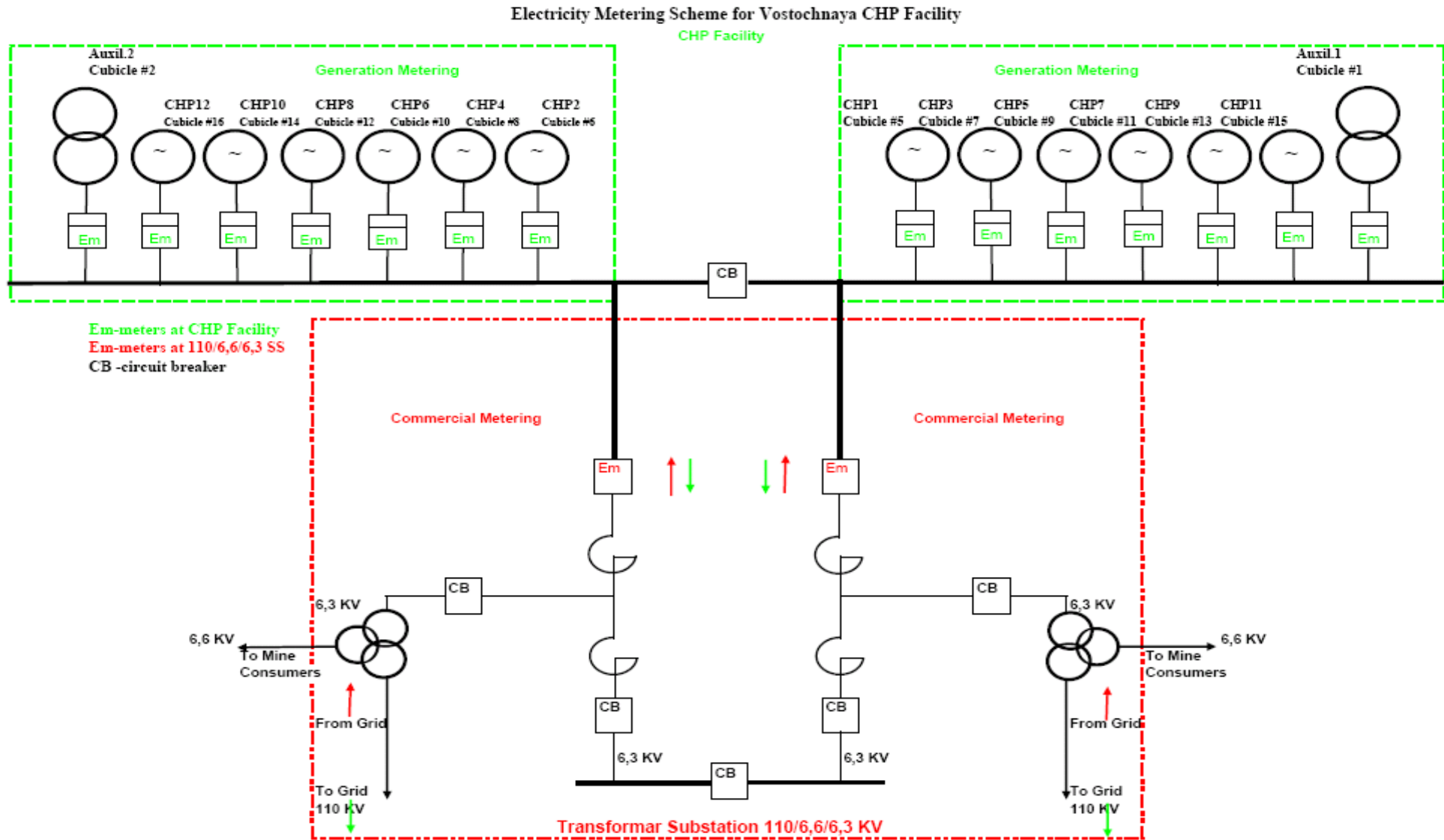

Figure 1: Electricity Metering Scheme for Vostochnaya CHP Facility

JI MONITORING REPORT

Heat Meter

Heat measurements

The amount of generated heat is measured at each individual cogeneration unit. The total amount of heat supplied by the CHP station to Vostochnaya site is monitored by the meters given below.

For this monitoring period only heat was supplied to the Vostochnaya site so for this monitoring period the amount of heat supplied by the CHP system to the heat transportation pipes is identical to the heat consumed by the Vostochnaya site. After Yakovlevskaya CHP plant will be commissioned it is planned to combine the heat system from both Vostochnaya and Yakovlevskaya sites with a help of Central Heat Distribution facility where all metering for the consumed heat of each site and the heat delivered to district heating will be individually measured. This would mean the installation of separate meters for the Centralnaya and Grigoryevskaya sites and the delivery to the DH-system.

As it is impossible to stop electricity generation all generated heat is dissipated in case of no demand. For this purpose the system contains lamellate radiators and was installed at the roof of CHP facility.

Measuring instrument	Work parameter GCal	Manufacturer	Type	Serial number	Uncertainty level of data, accuracy	Date of installation	Data 1.10.2008 Gcal	Data 31.12.2008 Gcal	Difference Gcal	Date of last calibre.	Date of next calibre.	Remarks
Heat meter SA 94/2M ¹³	Amount of heat delivered to site system	ASWEGA	Mechatronic	22903	±2%	N/A	61609	69817	8,208	04.06.07	04.06.09	T,V,Q (Total)

Calibration interval for heat meters is two years.

¹³ For meter SA 94/2M DN=300mm; Q=1000m³/h

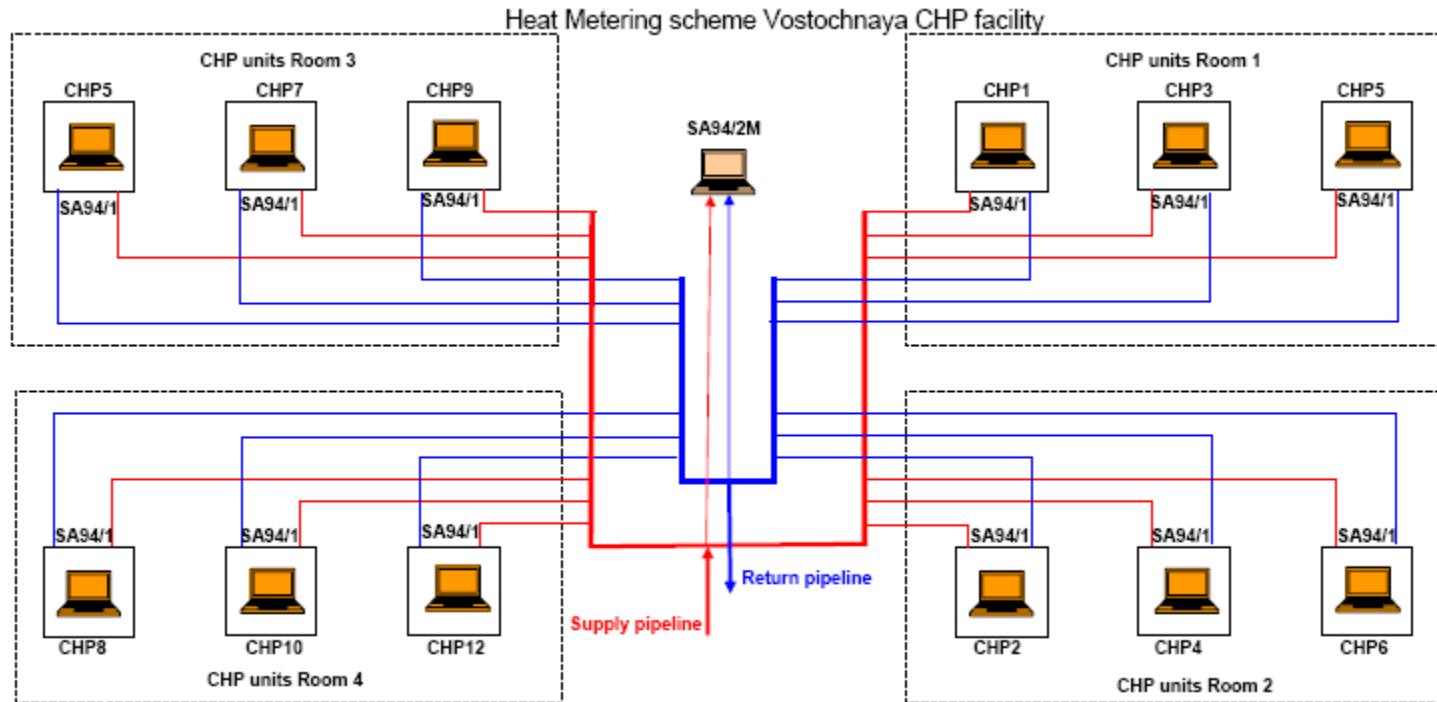

Figure 2: Heat Metering Scheme for Vostochnaya CHP Facility

JI MONITORING REPORT

The CMM consumption of the project can be separated in three parts:

1. Fuel gas consumption of the CHP units
2. Ignition gas consumption of the CHP units
3. Gas consumption of the AGFCP

To determine the amount of pure consumed CH₄ (in tonnes) the amount of pure CH₄ (in m³) has to be measured under normal conditions. The amount of pure CH₄ (in m³) can be measured (or more correctly: calculated) based on four parameters:

- Concentration (%) of CH₄ in the gas mixture
- Flow (m³) of gas mixture
- Temperature (C) of gas mixture
- Pressure (bar) of gas mixture

In the scheme below the different meters and sensors are indicated that are installed at the Vostochnaya site. We can classify the different meters/sensors:

- Primary meters/sensors that supply the data for determining the emission reductions as provided in section D of the Monitoring Report;
- Secondary meters/sensors used for cross-checking the data of the primary meters;
- Tertiary meters/sensors used to operated and control the installation only.

The tertiary meters/sensors are not of interest for monitoring purposes and are not mentioned further. In the table below the primary (yellow) and secondary meters/sensors (orange) are indicated with their number which listed in the scheme.

	Primary meters/sensors	Secondary meters/sensors used for determining CMM consumption for cross-checking purposes
Fuel gas		
Concentration (%)	K7	ABB AO 2040 (A1)
Flow (V)	G1-G12 ¹⁴	Gn5
Temperature (T)	T6-T17	Gn5 sensor
Pressure (P)	P11-P22	P6(Gn5's sensor)
Unit that converts data into pure methane (m3)	Automatic control system in dispatch	DBT equipment
Ignition gas		
Concentration (%)	ABB AO 2040 (A2)	ABB AO 2040 (A2)
Flow (V)	G13	Gn6
Temperature (T)	T5	Gn6 sensor
Pressure (P)	P10	P10(Gn6's sensor)
Unit that converts data into pure methane (m3)	‘Universal’ metering system	DBT equipment
AGFCP gas		
Concentration (%)	ABB AO 2040 (A2)	ABB AO 2040 (A2)
Flow (V)	G14	Calculations according to pressure difference
Temperature (T)	T18	

¹⁴Meters G1-G12 are being used as primary meters.

JI MONITORING REPORT

Monitoring Report#5 "Utilization of Coal Mine Methane at the Coal Mine named after A.F.Zasyadko" page18

Pressure (P)	P23	Manometers at AGFCS
Unit that converts data into pure methane (m3)	G14	Calculations

Table 4: Primary and secondary (cross-checking) metering of CMM

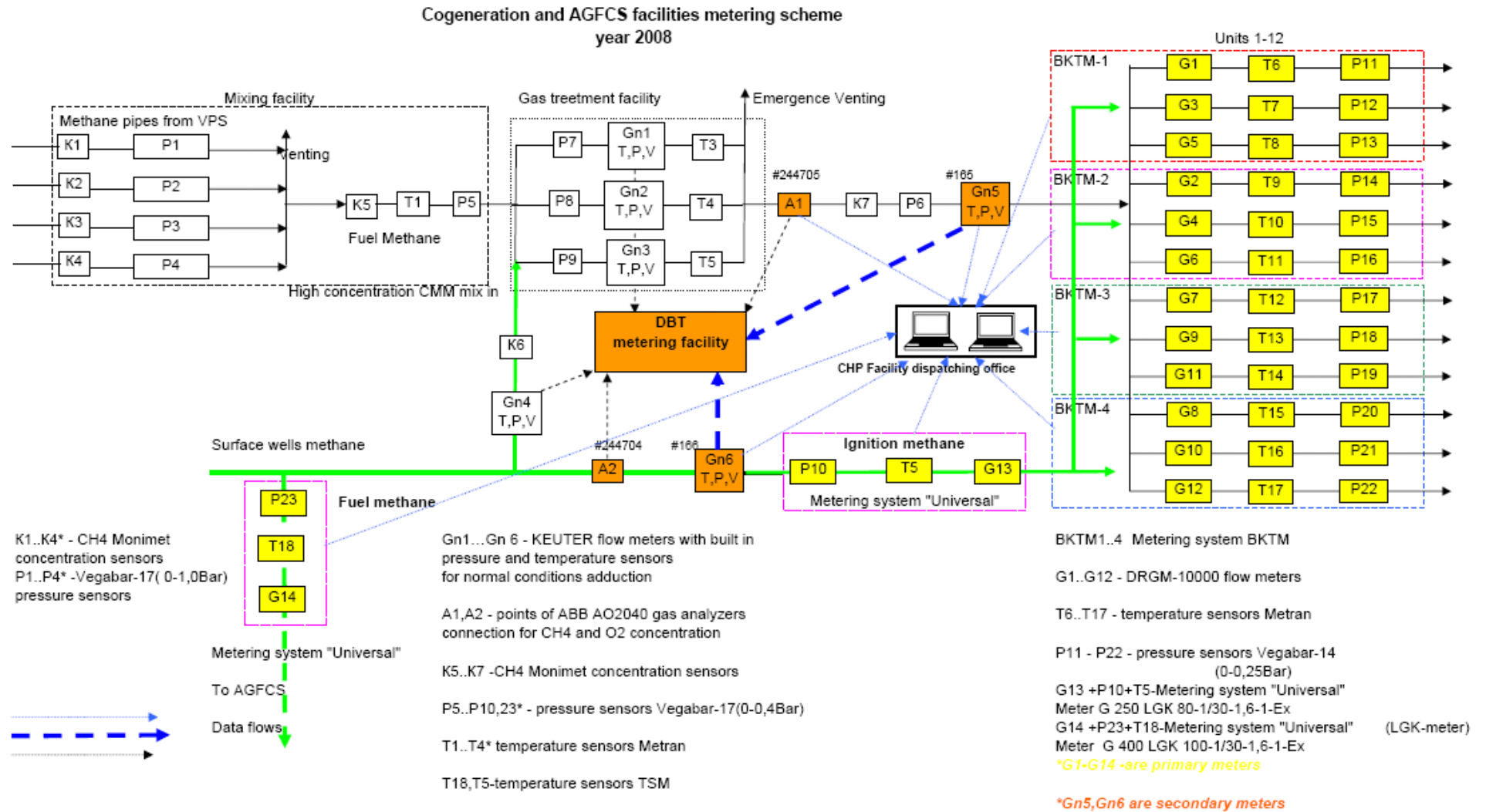

Figure 3: CMM metering scheme since year 2008

JI MONITORING REPORT FORM

Monitoring Report #5 “Utilization of Coal Mine Methane at the Coal Mine named after A.F. Zasyadko” page 20

The general flow of CMM and the metering can be described as follows.¹⁵

Coal mine gas of degassing and gas-suction activities is supplied through four lines from two Vacuum Pump Station (VPS) to the gas mixing section of the CHP gas treatment facility. The concentration and pressure of methane are different in each pipe-line. These parameters are measured by K1...K4 Monimet concentration sensors and P1...P4 Vegabar pressure sensors. *Measurements data of these sensors are not used in gas metering and are needed for operational purposes*; these data are channelled to an automatic control system of the dispatch *and used only for controlling purposes* in order to obtain at the output homogeneous fuel methane with necessary concentration.

The methane concentration that is fed to the gas treatment facility is measured by the Monimet K5 sensor. Also in the flow the T1 temperature sensor and the P5 pressure sensor are installed. Methane from surface wells is mixed into fuel methane in case of necessity to increase the concentration. The flow of goaf wells methane is measured by Gn4 flow meter Keuter together with velocity pressure and temperature sensors. The concentration of mix in methane from goaf wells is measured by Monimet K6 sensor. Having all this data the automatic control system of the dispatch can calculate the amount of methane in the gas mixture.

At the gas treatment section of the facility methane is distributed between three lines where it is dried, cooled, cleaned and wormed. Flow measurements are provided by Gn1 - Gn3 Keuter flow meters together with velocity, pressure and temperature sensors. They transmit information to the calculation equipment developed by DBT which is installed in separate premise of the gas metering section. This block calculates the values of actual consumption for normal conditions and channel them to the automatic control system of the dispatch computer system for operation. For checking and reserve, pressure P7 – P9 and temperature T2 – T4 sensors have been installed in the pipelines.

At the outflow of gas treatment section the processing discharge valve is installed which smoothes the pressure swings at abrupt changes of the CHP operation regime. Pressure at the outflow of the section is controlled by processing sensor P6.

For the purpose of fuel gas concentration determination, gas testing is made at the outflow of the gas treatment section of facility at point A1 which is fed to the gas analyzer AO 2040 (ABB) mounted at gas metering unit. Metered concentration is checked for the compliance with sensor date Monimet K7. The flow meter Gn5 (Keuter) as a unit with speed, pressure and temperature sensors measures the gas amount used by CHP units. The methane amount is calculated based on the data of methane concentration *but is not used monitoring purposes*.

Then fuel gas is supplied to the units of CHPs engine rooms. The flow meters G1- G12, type DPG.M-10000, temperature sensors T6 - T17 and pressure sensors P11 - P22 are mounted on the line of each 12 units. Their data are transmitted to microprocessing control system BKT.M for calculation of fuel gas amount which is used by each unit and total amount in each engine room. Fuel gas amount is calculated based on the data of methane concentration in it. *Total amount in engine rooms gives the methane amount in fuel gas utilized by CHP and is recorded in the database.*

¹⁵ From year 2008 DBT equipment is used as cross-checking equipment. Main meters installed at each CHP unite will be channel data to BKT.M metering system. The BKT.M meters will channel data to computer system. Besides all the data will be store at four BKT.M. Every “BKT.M unite” combines three CHP’s. These systems operates with fuel methane. The ignition methane for all CHP is measured with a new metering system “Universal” which is include LGK-Meter, temperature, pressure and flow sensors. All these data are stored at place and channel to CHP plant computer system.

JI MONITORING REPORT FORM

Monitoring Report #5 “Utilization of Coal Mine Methane at the Coal Mine named after A.F. Zasyadko” page 21

Ignition gas is supplied to the CHP units from the gas pipes of surface degasification boreholes. Total current ignition gas consumption is metered by flow meter G13 (Universal). Gas concentration is metered by gas analyzer AO 2040 (ABB) with gas test at the point A2, pressure and temperature are measured by sensors P10 and T5. Based on it automatic control system of dispatch service determines the methane amount which is fed to the CHPs with *ignition gas which is recorded in database.*

Gas that is supplied for automobiles filling is metered by sensor G14 “Universal”, pressure and temperature are measured by sensors P10 and T18. Based on it the methane amount fed to AGFCS for *automobiles filling and recorded in database.*

Methane volume which is supplied with fuel gas and methane of ignition gas gives total amount of methane supplied to CHPs.

Methane volume which is supplied with fuel gas and methane of ignition gas, methane for automobiles filling gives total amount of methane consumed by Zasyadko coal mine Vostochnaya site.



Figure 4: Sensors of flow, temperature and pressure at the CHP unit fuel methane pipeline

In the table below the description of the secondary meters (indicated brown in the schema) are given:

JI MONITORING REPORT

Monitoring Report #5 "Utilization of Coal Mine Methane at the Coal Mine named after A.F. Zasyadko"

page 22

Gas treatment section measuring equipment¹⁶

Gas analyzers

Measuring instrument Concentration ¹⁷	Work parameter, %	Manufacturer ¹⁸	Type	Serial number	Uncertainty level of data, accuracy	Date of installation	Date of last calibr.	Date of next calibr.	Remarks
Concentration of fuel gas	Concentration, %	ABB	AO2040 Electronic	3.244705. 5	±1%	2005	10.07.08	10.07.09	A1 connection
Concentration of ignition gas	Concentration, %	ABB	AO2040 Electronic	3.244704. 5	±1%	2005	11.07.08	11.07.09	A2 connection

Calibration interval for gas analyzers is two years

Flow meters¹⁹

Measuring instrument	Work parameter, m ³ /h	Manufac turer	Type	Serial number	Uncertainty level of data, accuracy	Date of install lation	Data 1.10.2008 m3	Data 31.12.2008 m3	Diffe rence m3	Date of last calibr.	Date of next calibr.	Re marks
Amount of ignition gas	Volume of combustible methane supplied to CHP modules	NVP"GREM PIS" ltd	Univers al-2	6023	±1%	4-th quarter 2007	1 670 318.9	2 038 654.1	368,335	23.07.08	23.07.10	Main meter
Amount of fuel gas	Volume of methane supplied to AGFCS	NVP"GREM PIS" ltd	Univers al-2	327	±1%	4-th quarter 2007	3 012 583	3 529 833	517,250	28.07.08	28.07.10	Main meter

Calibration interval for flow meters is two years

¹⁶ For technical date of the pressure and temperature sensors please refer to annex 4

¹⁷ See supporting document SD_1_CMM analysis

¹⁸ One and a half year manufacturer warranty obligations from commission date.

¹⁹ Flow meters data is for standard conditions. Coefficient to adjust to normal conditions is 0,938

JI MONITORING REPORT

Monitoring Report #5“Utilization of Coal Mine Methane at the Coal Mine named after A.F. Zasyadko”

page 23

BKTM data for fuel gas consumption

Measuring instrument Flow meters	Work parameter, m3/h	Manufactu rer	Type	Serial number	Uncertainty level of data, accuracy	Date of instal lation	Data 1.10.2008 m3	Data 31.12.2008 m3	Diffe rence m3	Date of last calibr.	Date of next calibr.	Remarks
Volume of combustible methane consumed as fuel gas at each CHP module (1)	Volume of combustible methane supplied to CHP modules	Sibneftea vtomatic a, Russia	DRGM Elec- tronic	102	±1%	N/A	10854133	13472130	2,617,997	16.07.08	16.07.11	BKTM1
Volume of combustible methane consumed as fuel gas at each CHP module (2)	Volume of combustible methane supplied to CHP modules	Sibneftea vtomatic a, Russia	DRGM Elec- tronic	108	±1%	N/A	10118093	14554379	4,436,286	15.07.08	15.07.11	BKTM2
Volume of combustible methane consumed as fuel gas at each CHP module (3)	Volume of combustible methane supplied to CHP modules	Sibneftea vtomatic a, Russia	DRGM Elec- tronic	109	±1%	N/A	10285075	13226072	2,940,997	18.07.08	18.07.11	BKTM1
Volume of combustible methane consumed as fuel gas at each CHP module (4)	Volume of combustible methane supplied to CHP modules	Sibneftea vtomatic a, Russia	DRGM Elec- tronic	104	±1%	N/A	2923449	2923449	0	15.07.08	15.07.11	BKTM2
Volume of combustible methane consumed as fuel gas at each CHP module (5)	Volume of combustible methane supplied to CHP modules	Sibneftea vtomatic a, Russia	DRGM Elec- tronic	103	±1%	N/A	10200714	13746306	3,545,592	17.07.08	17.07.11	BKTM1
Volume of combustible methane consumed as fuel gas at each CHP module (6)	Volume of combustible methane supplied to CHP modules	Sibneftea vtomatic a, Russia	DRGM Elec- tronic	97	±1%	N/A	8022571	11930812	3,908,241	16.07.08	16.07.11	BKTM2

JI MONITORING REPORT

Monitoring Report #5“Utilization of Coal Mine Methane at the Coal Mine named after A.F. Zasyadko”

page 24

Volume of combustible methane consumed as fuel gas at each CHP module (7)	Volume of combustible methane supplied to CHP modules	Sibneftea vtomatic a, Russia	DRGM Elec-tronic	98	±1%	N/A	5403981	7638879	2,234,898	16.07.08	16.07.11	BKTM3
Volume of combustible methane consumed as fuel gas at each CHP module (8)	Volume of combustible methane supplied to CHP modules	Sibneftea vtomatic a, Russia	DRGM Elec-tronic	105	±1%	N/A	<u>14434110</u> 0	<u>17672176</u> 502033.3	<u>3,238,066</u> 502,033.3	17.07.08	17.07.11	BKTM4 ^{20, 21}
Volume of combustible methane consumed as fuel gas at each CHP module (9)	Volume of combustible methane supplied to CHP modules	Sibneftea vtomatic a, Russia	DRGM Elec-tronic	99	±1%	N/A	5867273	9685886	3,818,613	17.07.08	17.07.11	BKTM3
Volume of combustible methane consumed as fuel gas at each CHP module (10)	Volume of combustible methane supplied to CHP modules	Sibneftea vtomatic a, Russia	DRGM Elec-tronic	96	±1%	N/A	<u>12445160</u> 0	<u>16142021</u> 393066.7	<u>3,696,861</u> 393,066.7	18.07.08	18.07.11	BKTM4 ²²
Volume of combustible methane consumed as fuel gas at each CHP module (11)	Volume of combustible methane supplied to CHP modules	Sibneftea vtomatic a, Russia	DRGM Elec-tronic	101	±1%	N/A	6446656	8808041	2,361,385	17.07.08	17.07.11	BKTM3
Volume of combustible methane consumed as fuel gas at each CHP module (12)	Volume of combustible methane supplied to CHP modules	Sibneftea vtomatic a, Russia	DRGM Elec-tronic	100	±1%	N/A	7843509	7843509	0	15.07.08	15.07.11	BKTM4 ²²

²⁰ 17.12 2008 BKTM-4 went out of control. During two hours it was replaced with another one. Consumption of CMM during this time was not included in calculation of emission reductions. All details of event were stipulated in the shift registry.

²¹ Before 17.12.2008/
After 17.12.2008

Calibration interval DRGM flow meters is three years

The monitoring system for the emission reductions achieved in the course of the project implementation has been integrated in the Zasyadko Coal Mine existing controlling and reporting system. That allows for obtaining reliable and easy verifiable data related to the project performance, ensuring thus the quality and efficiency of the monitoring system.

All source information on performance parameters and calculations have been obtained directly on site and after that reported to the Coal Mine dispatching office. The work parameters of CMM flows as well as heat and power produced will be crosschecked to provide quality and reliability of monitored data. To ensure reliable and non-stop performance of cogeneration plant the inputs of natural gas from the natural gas pipeline are envisaged.

CMM consumption of gas filling stations

Each of two blocks of Vostochnaya gas filling station has records in the registers. Calculations of methane fueled are executed according to data pressure difference of manometers. Concentration of methane is measured monthly with ABB AO 2040 at Power Station and ground wells analysis. Besides, the concentration of methane is measured locally with an interferometer. Temperature and pressure meters are installed too. The volume of methane is measured by “Universal-2” metering system.

B.1.3. Calibration procedures

For Electricity Meters:

QA/QC procedures	Body responsible for calibration and certification
Calibration interval of such meters is six years. Calibration procedures for meters are implemented in compliance with calibration methodology developed for “Elster-Metronika” meters, Russia. Manufacturer's warranty-36 months	Ukrainian Centre for Standardization and Metrology

For Heat Meters

QA/QC procedures	Body responsible for calibration and certification
Calibration interval of such meters is two years. Calibration procedures for meters are implemented in compliance with calibration methodology developed for ASWEGA meters, Russia. Manufacturer's warranty-18 months	Ukrainian Centre for Standardization and Metrology

For CMM meters:

JI MONITORING REPORT

QA/QC procedures	Body responsible for calibration and certification
Keuter ADM1 Electronic. Calibration interval of such meters is 1 year ²² .	Ukrainian Centre for Standardization and Metrology
Gas Analyzer ABB A02040. Calibration interval of such meters is 1 year.	Ukrainian Centre for Standardization and Metrology

B.1.4. Involvement of Third Parties:

Ukrainian Centre for Standardization and Metrology²³.

B.2. Data collection (accumulated data for the whole monitoring period):

For the operational and management structure of the project see PDD, Figure 5 : *Monitoring and quality control system for Vostochnaya and Yakovlevskaya sites*

²² As there is no state regulation for such kind of equipment there was a decision of Ukrainian Centre for Standardization and Metrology for one year calibration period.

²³ All measurement equipment should be calibrated according to terms and methodology defined by this centre requirements.

JI MONITORING REPORT

Monitoring Report #5 “Utilization of Coal Mine Methane at the Coal Mine named after AF.Zasyadko” page 27

B.2.1. List of fixed default values:

ID number	Data variable	Source of data	Data unit	Comment
P6 CEF _{CH4}	Carbon emission factor for combusted methane	2006 IPCC Guidelines for National Greenhouse Gas Inventories. Volume 2: Energy Chapter 4: Fugitive Emissions	tCO ₂ e/tCH ₄	Set at 2.75 tCO ₂ e /tCH ₄ See also table CMM meters
P12 Eff _{CHP}	Efficiency of methane destruction/oxidation in CHP	2006 IPCC Guidelines for National Greenhouse Gas Inventories. Volume 2: Energy Chapter 4: Fugitive Emissions	%	Set at 99,5%
P14 Eff _{GAS}	Overall efficiency of methane destruction/oxidation at the vehicles	2006 IPCC Guidelines for National Greenhouse Gas Inventories. Volume 2: Energy Chapter 4: Fugitive Emissions	%	Set at 98.5%
P15 GWP _{CH4}	Global warming potential of methane	2006 IPCC Guidelines for National Greenhouse Gas Inventories. Volume 2: Energy Chapter 4: Fugitive Emissions	tCO ₂ e/tCH ₄	Set at 21

Table 5: Project variables

ID number	Data variable	Source of data	Data unit	Comment
B13 EF _{grid,produced,y}	Emissions factor of electricity of replaced grid electricity production by the project activity in year	See annex 2	tCO ₂ /MWh	See annex 2 PDD See also table “Electrical Meters”
B14 EF _{grid,reduced,y}	Emissions factor of electricity of replaced on-site electricity consumption by the project activity	See annex 2	tCO ₂ /MWh	See annex 2 PDD See also table “Electrical Meters”
B20 EF _{heat,vost}	Emissions factor for heat at Vostochnaya site in the baseline scenario	Boiler efficiency	tCO ₂ /GJ	See annex 2 PDD See also table “Heat Meters”
B22 EF _{heat,yak}	Emissions factor for heat at Yakovlevskaya site in the baseline scenario	Boiler efficiency	tCO ₂ /GJ	See annex 2 PDD See also table “Heat Meters”
B24 EF _{heat,centr}	Emissions factor for heat at Centralnaya site in the baseline scenario	Boiler efficiency	tCO ₂ /GJ	See annex 2 PDD. See also table “Heat Meters”
B25 VFUEL _y	Vehicle fuel provided by the project activity	Fuel Meters	GJ	This value will be calculated based MM _{GAS} of the project scenario

JI MONITORING REPORT

Monitoring Report #5 “Utilization of Coal Mine Methane at the Coal Mine named after AF.Zasyadko” page 28

				multiplied with LHV of methane
B26 EF _v	Emissions factor for vehicle operation replaced by the project activity	2006 IPCC Guidelines for National Greenhouse Gas Inventories. Volume 2: Energy Chapter 4: Fugitive Emissions	tCO ₂ /GJ	See annex 2 PDD

Table 6: Baseline Variables

B.2.2. List of variables:

Project emissions variables to be measured:

- MM_{CHP} Methane measured sent to power plant (tCH4)
 MM_{GAS} Methane measured supplied to gas grid for vehicle use (tCH4)

Baseline emissions variables to be measured:

- GEN_{CHP} Net electricity generated by the project activity by the CHP plants
 $El_{Consumed}$ Net electricity consumed by the mine on-site
 $HEAT_{cons, \text{vost}, y}$ Heat consumed at Vostochnaya site delivered by the project year y
 $VFUEL_y$ Vehicle fuel provided by the project activity

B.2.3. Data concerning GHG emissions by sources of the project activity (referring to paragraph 53(a)):

Year	MM_{GAS} (tCH4)
Total 2008 Q4	6,449

Table 7: Data to be collected in the project scenario

Year	MM_{CHP} (tCH4)
Total 2008 Q4	345

Table 8: Data to be collected in the project scenario

For Methane analysis data refer please to Annex 1 document.

B.2.4. Data concerning GHG emissions by sources of the baseline (referring to paragraph 53(b)):

Year	GEN_{CHP} (MWh)	El_{Cons} (MWh)	$HEAT_{cons, \text{vost}, y}$ (GJ)	$VFUEL_y$ (m3)
2008 Q4	30,338	43,768	34,365	481,042

Table 9: Data collected in the baseline scenario

B.2.5. Data concerning leakage (referring to paragraph 53(c)):

Not Applicable.

JI MONITORING REPORT

Monitoring Report #5 “Utilization of Coal Mine Methane at the Coal Mine named after AF.Zasyadko” page 29

B.2.6. Data concerning environmental impacts (referring to paragraph 53(d)):

Not Applicable.

B.3. Data processing and archiving (incl. software used):

All data will be archived electronic and paper.

B.4. Special event log:

The two explosions took place at October-November 2007 due to high depth of coal at the coal mine and unknown geological process. The two horizon-faces were closed and flooded. This caused decreasing of CMM extraction and electricity generation in November-December.

SECTION C. Quality assurance and quality control measures²⁴

C.1. Documented procedures and management plan:

C.1.1. Roles and responsibilities:

The general project management is implemented by the Deputy General Director of the Zasyadko Coal Mine through supervising and coordinating activities of his subordinates, such as deputy director on surface degasification, chief power engineer, chief heating engineer, and heads of safety engineering departments. On-site day-to-day management is implemented by the manager of cogeneration station who directs two shift operators responsible for cogeneration modules and gas treatment plant performance. An on-duty electrician works at the plant. During the daytime a group of mechanics who are responsible for preventive measures and maintenance of all technological equipment, measuring instruments as well as of automation tools and telemechanics are present on-site. On-line information transmitted directly to the head of the shift into the Coal Mine Central Dispatching Office. The cogeneration plant is in 24 hours operation. Three shifts by eight hours have been introduced.

At the main objects the responsibilities are as follows:

- VPS operator controls data before VPS and after VPS (at the gas treatment plant) including CMM and natural gas flow parameters;
- Two cogeneration plant operators control data at the inlets of cogeneration modules (at the gas treatment plant), work process parameters, and heat and power output;
- Substation operator controls data on electric power amounts dispatched to and supplied from the grid as well as in-house electricity consumption.

All the information will be channelled to the workstation of the Coal Mine central dispatching office and on-line monitored by the head of the shift that will be responsible for calculation of the CO₂ equivalent emission reductions. Such calculations are made on a monthly basis. The general supervision of the monitoring system is executed by Zasyadko Coal Mine administration under the existing control and reporting system.

C.1.2. Trainings:

The basic equipment for CHP plant, being the cogeneration units, was supplied by the GE Jenbacher Company (Austria). As stipulated in the delivery contract education of staff, that operates those units, were provided in Austria. Additional training was provided by GE Jenbacher technicians during installation and commissioning works. The employees responsible for the monitoring control also were dully trained during installation of such system.

Extra trainings are to be provided during operation of equipment. Training programs for CHP and VPS staff as well as Emergency training will be submitted as separate document.

C.2. Involvement of Third Parties:

The Ukrainian Centre for Standardization and Metrology is a Third Party involved.

C.3. Internal audits and control measures:

Introduction of a modern computerized control system allows for efficient on-line monitoring and reviewing work process performance at the Zasyadko Central Dispatching office every fifteen minutes. (Especially for fuel and

²⁴ See supporting document SD_2_Monitoring Manual

JI MONITORING REPORT

Monitoring Report #5 “Utilization of Coal Mine Methane at the Coal Mine named after AF.Zasyadko” page 31

ignition gas consumption, their parameters and electricity and heat generated data can be obtained every 10 seconds if requested). Any considerable deviation of monitored data from given work parameters will be promptly noticed and source of such deviation will be easily identified. In turn this enables the head of shift to efficiently coordinate adjustment actions of his shift subordinates including on-duty technical staff that will improve work process and eliminate such deviations.

C.4. Troubleshooting procedures²⁵:

See C .1.2

In case of a break down of CMM supply system (either of whole system or separate feeding pipe) methane-air mixture will be urgently released into the atmosphere through the emergency gas vent stack. The shut-off valves will automatically close CMM supply pipes, natural gas will be fed into gas treatment plant and consequently into the inlets of engines and into pre-chambers. As the primary meters are *after* the venting stack, only combusted CMM will be accounted for.

²⁵ There is all necessary metering equipment of the same type at the CHP facility to replace main equipment for short period in case of break down or calibration – electrical and heat meters, CMM metering equipment, pressure , temperature sensors, e .t. c. Being connected or installed these devices are able to channel all data to computer system of monitoring and control. This equipment is also calibrated by the Ukrainian Centre for Standardization and Metrology in certain time.

SECTION D. Calculation of GHG emission reductions (referring to Decision 17/CP.7, Annex H, paragraph 53 (f) and 59)

D.3.1. Project emissions:

		2008 Q4
Project emissions	[tCO ₂ e/yr]	19,366
<i>Total 2008 Q4</i>	[tCO ₂ e]	<i>19,366</i>

Table 10: Project emissions

D.3.2. Baseline emissions:

		2008 Q4
Baseline emissions	[tCO ₂ e/yr]	173,302
<i>Total 2008 Q4</i>	[tCO ₂ e]	<i>173,302</i>

Table 11: Baseline emissions

D.3.3. Leakage:

Not Applicable

D.3.4. Summary of the emissions reductions during the monitoring period:

		2008 Q4
Emission reductions	[tCO ₂ e/yr]	153,937
<i>Total 2008 Q4</i>	[tCO ₂ e]	<i>153,937²⁶</i>

Table 12: Emission Reductions

²⁶ Due to rounding of figures there is a difference of 1 tCO₂e.