



**JOINT IMPLEMENTATION PROJECT DESIGN DOCUMENT FORM**  
**Version 01 - in effect as of: 15 June 2006**

**CONTENTS**

- A. General description of the project
- B. Baseline
- C. Duration of the project / crediting period
- D. Monitoring plan
- E. Estimation of greenhouse gas emission reductions
- F. Environmental impacts
- G. Stakeholders' comments

**Annexes**

- Annex 1: Contact information on project participants
- Annex 2: Baseline information
- Annex 3: Monitoring plan
- Annex 4: References

**SECTION A. General description of the project****A.1. Title of the project:**

Modernization of OJSC “Solombala PPM” energy-generating facilities to reduce fossil fuel consumption, Arkhangelsk, Russian Federation

Sectoral scopes<sup>1</sup>: 1. Manufacturing industries (4)  
2. Waste handling and disposal (13)

Version: 1.3

Date: May 24, 2011

**A.2. Description of the project:****The project aim**

The project is aimed at retrofitting energy-generating facilities of OJSC “Solombala Pulp and Paper Mill” (SPPM) with a view to reducing its fossil fuel (coal and heavy fuel oil) consumption through employment of up-to-date technologies of bark and wood wastes (BWW) utilisation for energy generation with termination of BWW dumping.

Substitution of fossil fuel with renewable biomass, which BWW is, and reduction of biomass dumping volumes bring about greenhouse gas (GHG) emission reductions.

**Situation prior to the project implementation**

The principal product of SPPM is market pulp. Pulp cooking uses pulp chips, the production of which yields large quantities of BWW, including bark, sawdust and screenings of pulpchips. BWW is also a by-product of timber production.

The available BWW are a difficult-to-burn fuel due to their high moisture content and non-uniform particle size distribution. This is especially true about bark, whose moisture content may reach up to 70% and the size of particles may vary from several millimeters to several decimeters. Furthermore, bark combustion is made more challenging by the high tar content. Since BWW utilization as fuel entails numerous difficulties, there are extensive BWW dumping areas next to every saw mill in the Arkhangelsk Region. The saw mills’ heat demand is generally met by fossil fuel combustion at the sawmill itself and/or by outside energy supplying companies.

Prior to commencement of the project Solombala PPM was firing a limited amount of sawdust and chip screenings (in the order of 100 thousand dense m<sup>3</sup> per year), including supplies from the neighbouring wood working enterprises of Arkhangelsk which do not have their own wood wastes utilization capacities. Sawdust and chip screenings were fired in utilizing steam boiler No.1 of CKTI-40-34x2 type located in CHPP-1 of SPPM. This boiler was fitted with a sloping grate. Bark combustion was not technically possible in this boiler. Any attempt to burn bark in boiler No.1 led to rapid slagging of the boiler and even caused its breakdown. Moreover, even when sawdust and chip screenings were fired, the technological shortcomings of the boiler made it necessary to co-fire heavy fuel oil in order to sustain the combustion process (up to 30% by heat release), which was the reason of the low efficiency of the boiler in terms of wood waste utilization quantities.

Because the wood waste combustion capacities were limited and bark combustion was not technically possible, large quantities of surplus BWW were produced at SPPM production site and neighbouring enterprises. These wastes had to be transported to dumping areas for disposal. Steam in CHPP-1 was mainly produced by heavy fuel oil and coal-fired boilers.

<sup>1</sup> In accordance with the list of sectors approved by JISC. [http://ji.unfccc.int/Ref/Documents/List\\_Sectoral\\_Scopes.pdf](http://ji.unfccc.int/Ref/Documents/List_Sectoral_Scopes.pdf)



### The baseline scenario

The baseline scenario assumes that without the joint implementation mechanism and sale of GHG emission reductions the Mill would have continued its BWW handling and energy generation practices without any grave barriers at least up until 2012.

Further use of the existing energy capacities can meet the SPPM's heat requirements. Technical condition of utilizing boiler No.1 is such that its operation can be maintained at the same level for a number of years by carrying out relatively inexpensive routine maintenance. This means that some amount of sawdust and chip screenings produced at the Mill and supplied from the outside can be utilized for steam production purposes without incurring any large and risky capital expenditure.

Bark as well as surplus sawdust and chip screenings would have continued to be disposed at the dump which does not violate any Russian environmental regulations, does not entail significant costs and is historically a practice that is widely used in wood processing industry of Arkhangelsk and Russia, in general.

The missing quantity of steam would have been produced in CHPP-1 by heavy fuel oil and coal-fired boilers, whose technical condition does not cause any concerns and allow to operate their capacities without any constraints.

### The project scenario

The project envisages replacement of heavy fuel oil fired boiler No.5 of KM-75-40 type (CHPP-1) with a boiler fitted with a fluidized bed furnace extension designed for BWW combustion, enhancement of the boiler's nominal output to 90 t/h, replacement of the ash handling equipment and construction of a new system for BWW handling, preparation and feeding to CHPP-1 for combustion.

The suppliers of the main equipment are LLC "INEKO" (boiler with fluidized bed furnace extension), Saalasti OY, Finland (BWW preparation for combustion), LLC "Energomashtehnologia" (electrostatic precipitator).

Boiler No.1 after the project implementation continues its operation, firing sawdust and chip screenings.

The expected results of the project<sup>2</sup>:

- The project enables additional utilization of 262 thousand dense m<sup>3</sup> of BWW per year for heat and electricity generation purposes by allowing bark combustion, as well as by increasing efficiency and volumes of sawdust and chip screenings combustion. This means that dumping of BWW from SPPM's production site and neighbouring wood working enterprises is almost completely avoided.
- Reduction in the proportion of fossil fuel in SPPM's fuel mix. Reduction in heavy fuel oil consumption – by 31 thousand tonnes per year; reduction in coal consumption – by 26 thousand tonnes per year.
- Optimization of the Mill's energy generation scheme, enhancement of its reliability and cost effectiveness.
- Mitigation of negative environmental impact, including reduction in GHG emissions by 259.0 thousand tCO<sub>2e</sub> per year.

---

<sup>2</sup> Figures are given as an average for the period 2008-2012



### The project history

The decision to launch this project was made by the Mill's management on the 10<sup>th</sup> of December 2000 by signing with CJSC "AMU Sevzapenergomontazh" a contract [R9] on replacement of KM-75-40 boiler unit No.5 of CHPP-1.

At the time of the decision making the planned cost of project implementation (including construction of BWW preparation facility) was estimated at RUR 128.7 million (USD 4.6 million).

Originally the boiler No.5 replacement project [R10] involved installation of a wet flue gas treatment system based on an emulsifier and multicyclone ash collectors. This flue gas treatment system was selected on account of its relative cheapness (compared to the cost of electrostatic precipitator). However, operation of the retrofitted boiler showed that the emulsifier was unable to achieve its treatment targets. Moreover, inefficient gas treatment caused rapid slagging of the boiler, consequently heat exchange surface shrank and the boiler efficiency dropped. In 2007 the wet flue gas treatment system of boiler No.5 was substituted with an electrostatic precipitator. At the time when the decision was made to implement the project the Mill did not expect that the gas treatment system would have to be replaced.

Table A.2-1 below shows the dates when the project components were officially accepted for commissioning, specifying the actual capital expenditure per component.

**Table A.2-1. Commissioning dates of the project components and their actual costs**

Project components	Commissioning dates	Costs, million RUR
Replacement of heavy fuel oil steam boiler No.5 of KM-75-40 type with installation of fluidized bed furnace extension for BWW combustion, and replacement of ash collecting equipment	30.06.2003 [R16]	131.3
Construction of a facility for BWW handling, preparation and feeding for combustion to CHPP-1	30.09.2004 [R17]	77.2
Replacement of a wet flue gas treatment system of steam boiler No.5 and installation of an electrostatic precipitator	29.12.2007 [R18]	42.3
<b>Total project investments</b>		<b>250.8</b>

When taking the decision to implement the project, the management of SPPM from the very beginning considered the possibility of implementing it as a carbon project in order to mobilize the required financing resources and ensure acceptable return on investments.

In March 2000 Solombala PPM held a technical meeting where it discussed replacement of one of the heavy fuel oil boilers of CHPP-1 and its conversion to wood wastes combustion [R8]. At the meeting it was stated that the project would lead to GHG emission reductions and that sale of emission reductions using the joint implementation (JI) mechanism provided for by Article 6 of the Kyoto Protocol would allow to reduce considerably the project pay-back period.

The same year SPPM management submitted an application to the Executive Directorate of National Pollution Abatement Facility (NPAF) for obtaining financing for the investment project aimed at the Mill reconstruction for the purpose of bark and wood wastes utilization and reducing energy requirements of the pulp production process. The submitted documents contained an estimation of expected GHG emission reductions. The investment project was approved by the Supervisory Board of NPAF. It took into account the fact that the project falls under the category of GHG emission reduction projects. The NPAF ED recommended SPPM to start preparing the documentation which is necessary to implement the project in accordance with the joint implementation scheme with a foreign partner.

The issues pertaining to JI project preparation were discussed with different companies, including Autonomous Non-Commercial Organization "Environmental Investment Center" (ANO "EIC") (2000-2006), Camco International (2007-2009), CCGS LLC (2010).

It is worth mentioning that in 2001 specialists of ANO “EIC” made the first attempt to set the baseline for the BWW utilization project, and developed a preliminary inventory of GHG emissions at SPPM for the period 1990-2000 [R15]. In 2004 ANO “EIC” elaborated for demonstration purposes the project design document and a proposal for participation in the project aimed at identification of potential Joint Implementation Projects in Russia organized by the Agency of Direct Investments financed by the Government of Luxemburg.

**A.3. Project participants:**

Party involved	Legal entity, project participant (as applicable)	Please indicate if the Party involved wishes to be considered as project participant (Yes/No)
Party A: Russia (host Party)	Open Joint Stock Company “Solombala Pulp and Paper Mill”	No
One of the Parties of Annex B to the Kyoto Protocol	To be determined within 12 months after approval of the project by the Russian Government	No

**Open JSC “Solombala Pulp and Paper Mill”**

“Solombala Pulp and Paper Mill” is located on Great Solombala Island in the estuary of the Northern Dvina River in Solombala-Maimaksa Industrial Hub of Arkhangelsk. The fenced territory of the enterprise is 87.5 hectares.



**Fig. A.3-1. Solombala PPM**

The core business of Solombala PPM is production and sale of unbleached sulphate pulp, as well as wood chemical and paper by-products. Furthermore, the Mill supplies heat to the nearby enterprises and organizations of Solombala-Maimaksa Industrial Hub of Arkhangelsk. The wastewater treatment plant operated by the Mill is also responsible for biological treatment of domestic sewage of Arkhangelsk and industrial sewage of Arkhangelsk Hydrolysis Plant.

The Mill is linked by highways with Arkhangelsk City, Maimaksa timber mills and communities, and by a railway via Solombalka railway station it is connected with Arkhangelsk City Station and “Ekonomia” Port.

Construction of the Mill started in 1934. The first phase of sulfate pulp plant capable of 16 800 tonnes of pulp per year was commissioned in 1936. The rated pulping capacity of Solombala PPM which was accepted for operation is, as of today, 288 500 tonnes of pulp per year. However due to wear out and decommissioning of some equipment of the pulping lines stable operation is ensured at the level of 210 000 - 230 000 tonnes per year.

The enterprise accounts for up to 10% of the world market of unbleached sulfate pulp, and for around 50% of the Russian market. Over 80% of all produce of the Mill is exported. Pulp of “Solombala” brand is purchased in thirty countries of Eastern and Western Europe, Northern Africa, South-East Asia, Middle East and Northern America.

The integrated quality and environmental management system to the requirements of international standards ISO 9001 and ISO 14001 is functioning at the enterprise and is being constantly improved.

Today OJSC “Solombala PPM” is a part of a large regional timber holding, “Solombales”, one of the major players in the timber sector of the Arkhangelsk Region.

#### **A.4. Technical description of the project:**

##### **A.4.1. Location of the project:**

Location of the project: Russian Federation, Arkhangelsk, OJSC “Solombala Pulp and Paper Mill” (See Fig. A.4-1, A.4-2).



**Fig. A.4-1. Location of Arkhangelsk Region and the city of Arkhangelsk on the map of Russia**



Fig. A.4-2. Google Earth map pinpointing the project activity

**A.4.1.1. Host Party(ies):**

Russian Federation

**A.4.1.2. Region/State/Province etc.:**

Arkhangelsk Region

**A.4.1.3. City/Town/Community etc.:**

City of Arkhangelsk

**A.4.1.4. Detail of physical location, including information allowing the unique identification of the project (maximum one page):**

Arkhangelsk Region lies in the North of the European part of Russia and is a part of the North-West Federal District of the Russian Federation.

It covers an area of 587 000 km<sup>2</sup>. The population level is 1.3 million, of which urban population is around 1 million. The territory of the region includes Nenets Autonomous Okrug, 21 administrative districts, 14 cities, 31 urban settlements, around 4 000 rural settlements, and the islands of Novaya Zemlya and Franz-Josef Land.

The administrative centre of the region is the city of Arkhangelsk. The city is located in the estuary of the Northern Dvina River, 40-45 km from where it falls into the White Sea, 1133 km North of Moscow. The population is 351 600.

The climate is subarctic, maritime with long winters and short cool summers. It is formed under the influence of the northern seas and air mass transfer from the Atlantic under the conditions of low solar radiation. The average temperature of January is  $-13^{\circ}\text{C}$ , of July  $+17^{\circ}\text{C}$ . The annual precipitation rate is 529 mm.





Geographic coordinates of the project activity: latitude: 64°35'N, longitude: 40°33'E. Time zone GMT: +3:00.

**A.4.2. Technology(ies) to be employed, or measures, operations or actions to be implemented by the project:**

**Description of SPPM's energy system**

The core business of Solombala PPM is production of unbleached sulfate pulp which is sold in the Russian market and internationally. Production of pulp, as well as wrapping paper, tall oil and products of its distillation requires heat (process steam) and power. The unbleached sulfate pulp production line has a technological CHPP-2, which by means of chemical regeneration produces steam for process needs, meeting up to 70% (in summer) and up to 60% (in winter) of the demand. The rest of the heat demand is ensured by CHPP-1. It consists of five energy-generating boilers. Table A.4-1 contains a short description of CHPP-1 boilers as they were prior to the project implementation.

**Table A.4-1. Description of CHPP-1 boiler units prior to the project**

Boiler No.	Type	Fuel (main/backup)	Nominal output, t/h
No.1	CKTI-40-34x2	sawdust, chip screenings/heavy fuel oil	40
No.2	CKTI-40-34x2	coal/ heavy fuel oil	40
No.3	CKTI-40-34x2	coal/ heavy fuel oil	40
No.4	KM-75-40	heavy fuel oil	75
No.5	KM-75-40	heavy fuel oil	75

Boiler No.1 runs on sawdust and chip screenings with a significant amount of heavy fuel oil added to sustain the combustion process. The main supplier of saw dust is Solombala Saw Mill (SSM) located on the same production site with the SPPM. The sawdust from SSM is fed to CHPP-1 by a belt conveyor. Most of steam in CHPP-1 is generated by firing coal and heavy fuel oil.

Four steam turbine units are installed in the turbine hall of SPPM for power generation. The total installed capacity of the turbines is 36 MW – 2x6 MW and 2x12 MW. Steam is supplied to the turbine hall via a common header from both CHPPs. The power demand is variable, which means the company may consume the deficient amount of electricity from the grid or export the surplus to the grid in case the generation exceeds the demand.

**Description of the main project solutions**

The technological processes introduced under the project keep up to the world level of technology development in this sector. Technical feasibility of the project measures is demonstrated by the experience of individual enterprises of the Russian pulp and paper industry. All technological parameters comply with the relevant environmental requirements and standards.

The project measures led to significant reduction in greenhouse gas emissions due to larger volumes and higher efficiency of BWB combustion, with bark being included into the Mill's fuel mix.

Originally the project envisaged the following measures:

1. Replacement of heavy fuel oil steam boiler No.5 (CHPP-1) of KM-75-40 type which meant its complete replacement with a new boiler, including replacement of the ash collecting equipment, to enable combustion of BWB using fluidized bed technology, and increase of steam output to 90 t/h [R10];
2. Construction of a facility for BWB handling, preparation and feeding it for combustion to CHPP-1 [R11].





Later on, because of the identified problems with the wet flue gas treatment system installed on the replaced boiler No.5 it was decided to replace the flue gas treatment system, therefore one more component was added:

3. Replacement of the wet gas treatment system of steam boiler No.5 with installation of a single-stage electrostatic precipitator of EGU 105-21-12-9WS640-400-1 type [R12].

It should be noted that without the project heavy fuel oil fired boiler No.5 would be able to continue its operation in normal mode at least until 2012 given that the relevant planned maintenance is carried out, which is confirmed, inter alia, by the fact that boiler No.4 (which was installed the same year as boiler No.5) is still operating.

### **Fluidized bed combustion of wastes**

Fluidized bed combustion of wastes ensures efficient, cost-effective and environmentally safe combustion of fuels with high moisture content and low calorific value. Fluidized bed is formed by screened natural sand, which is made to behave like a bubbling fluid by streams of passing primary air. The air is supplied by a high-pressure fan via nozzles, installed underneath the grating. The layer of sand is heated by start-up heavy fuel oil burners to the temperature required to trigger solid fuel combustion and to stabilize the flame.

The project envisages replacement of energy-generating boiler No.5 (KM-75-40) of CHPP-1, running on heavy fuel oil, with a new bark-fired boiler with steam output of 90t/h designed for fluidized bed combustion of BWW. The technology developed by "INEKO" company was chosen for replacement of the boiler. Unlike traditional fluidized bed technology, INEKO's original technology envisages formation of fluidized bed not in the boiler furnace but in a special furnace extension. "Furnace extension – furnace" configuration ensures longer fuel-residence time in the active combustion zone compared to traditional fluidized bed boilers, which is especially important when firing sawdust and other fine wood wastes mixed with bark.

The replaced boiler uses a two-stage BWW combustion technology.

The first stage of waste combustion ("gasification") takes place in the water-cooled furnace extension with a fluidized bed made of inert filling material (silica sand with particle-size distribution of 0.8-2.0 mm) at 650-750°C. Reburning of "gasification" products and carried-over wood semi-coke fines (second stage) takes place in the furnace of the boiler by means of supplying over-fire air (secondary and tertiary air). This increases boiler efficiency through reduction of incomplete combustion and carbon loss.

The flow diagram of the new boiler is shown in Fig. A.4-3.

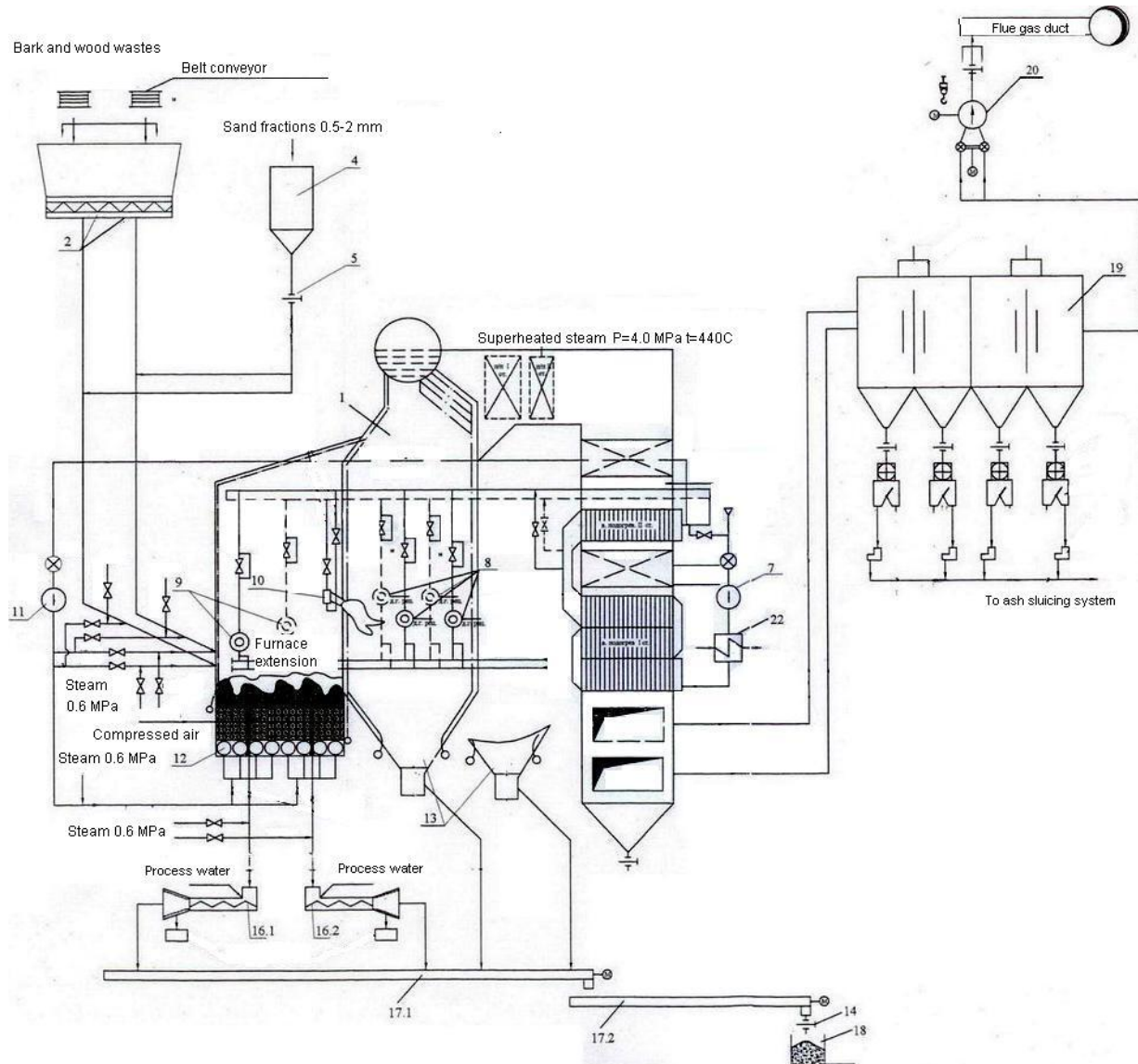
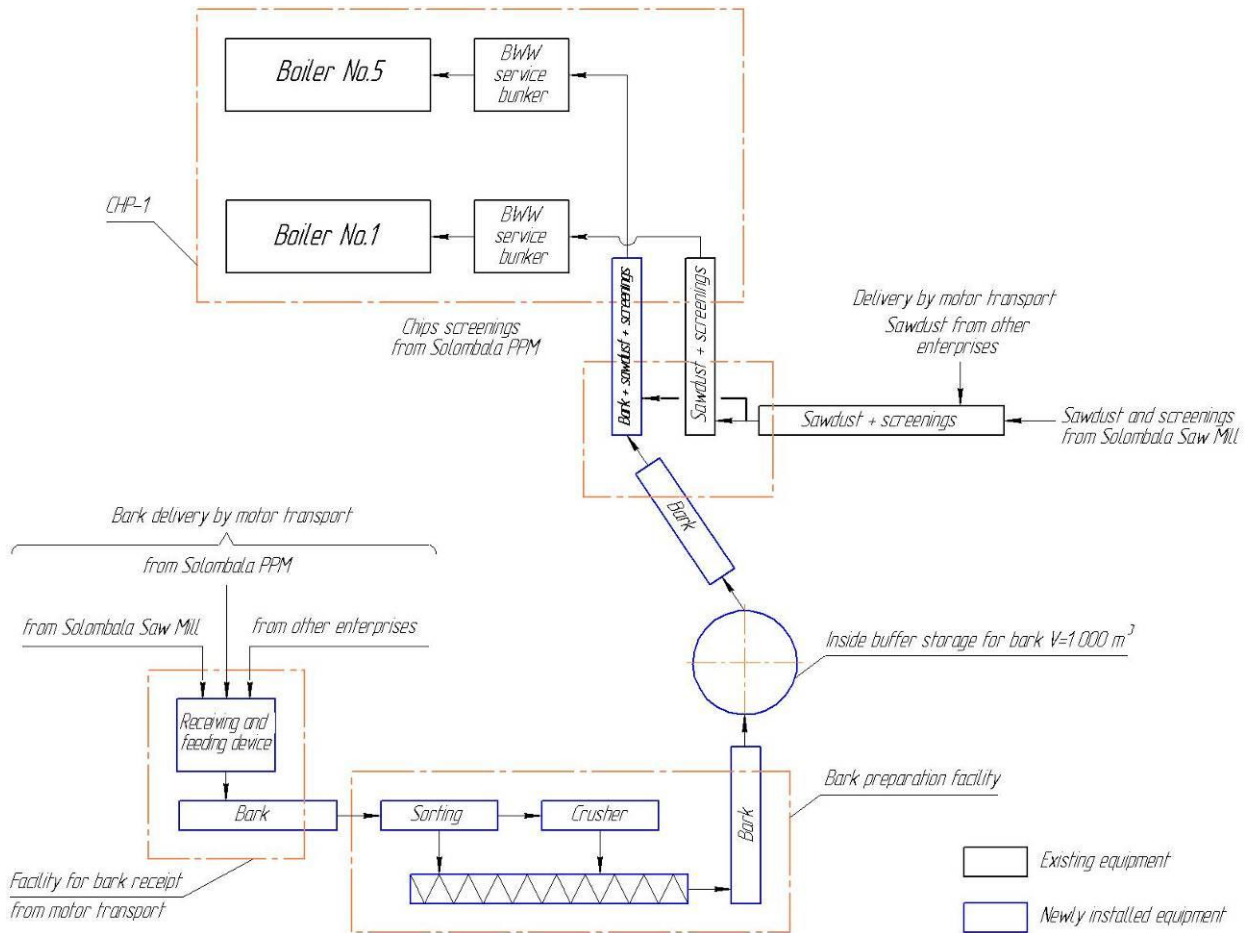

**Fig. A.4-3. The flow diagram of KM-75-40 boiler after replacement**

1 – KM-75-40 boiler; 2 – BWW bunker with a “moving bottom”,  $V=90\text{ m}^3$ ; 4 – sand bunker,  $V=2.6\text{ m}^3$ ; 5 – ash-sludging device; 7 – VDN-20 forced draft fan; 8 – GM-15 boiler burner (4 nos.); 9 – GM-4.5 furnace extension burner (2 nos.); 10 – secondary air nozzles (12 nos.); 11 – VGD-22SD high-pressure hot-blast fan; 12 – air grate; 13 – bottom air blasting device (2 nos.); 14 – gate valve of ash and slag bunker; 16.1, 16.2 – slag screw feeder (with sieving, right side and left side respectively); 17.1, 17.2 – KPS scraper conveyor; 18 – ash and slag bunker,  $V=11.5\text{ m}^3$ ; 19 – EGU105-21-12-9WS640-400-2 electrostatic precipitator; 20 – DN-26 induced draft fan; 22 – steam air heater.

### BWW handling, preparation and feeding facility

The facility for handling, preparation and feeding of BWW for combustion to CHPP-1 is designed for continuous supply of wood wastes of the required fraction to replaced boiler No.5 of CHPP-1. The process flow scheme of BWW preparation and transportation is shown in Fig. A.4-4 below.



**Fig. A.4-4. The process flow scheme of BWW preparation and transportation**

In accordance with the process flow scheme the project envisages building and reconstruction of the following facilities of the BWW preparation and transportation complex:

*Bark handling facility with a roofed platform and motor transport access*

Bark handling facility is to be located under a shed, 6m high measured from the basement of the building structure. The bark delivered by motor transport is discharged into a bunker. The bunker is fitted with a receiving/feeding scraper device manufactured by “Saalasti OY”. The bark is transported from the bark handling facility to the bark preparation facility by belt conveyor. The belt conveyor has an iron separator to remove metal objects from bark. In addition a metal detector is installed to detect remaining metal objects and to shutdown the conveyor.

*Bark preparation facility*

Bark preparation facility designed for bark crushing to the required fraction size will be located in a heated building measuring 18m in width.

Bark preparation equipment includes a disk screen and a crusher integrated into a single complex by a screw conveyor.

Fine fractions of bark which do not require crushing pass through the disk screen and are transported by the screw conveyor on to the belt conveyor of the bark feeding line leading to an inside buffer storage, and only coarse fractions are fed to the crusher.

To provide for bark crushing to the required size a Saalasti 0912 crusher with throughput capacity of 150 bulk m<sup>3</sup>/h is to be installed.



### *Inside buffer storage*

Mechanized storage for a buffer stock of ready-for-combustion bark has holding capacity of 1000 bulk m<sup>3</sup>. Bark will be transported to the storage by a belt conveyor. The storage is a cylindrical bunker measuring 13m in diameter fitted with rotating screw dischargers of CRS-5 type manufactured by "Saalasti". The holding capacity of the bunker is sufficient to ensure, on average, 12-14 hours of operation of boiler No.5.

### *Bark and sawdust feeding lines*

Bark will be transported from the bark receipt facility to the bark preparation facility, from the preparation facility to the inside storage and further from the inside storage to the existing discharge and mixing shed by a belt conveyor via newly designed flyovers. The throughput capacity of the conveyors is 150 bulk m<sup>3</sup>/h.

Sawdust is fed to the discharge and mixing shed via the existing line. Sawdust is transported from Solombala Saw Mill (directly and via outside storage).

Bark and wood wastes are mixed in the existing discharge and mixing shed, located at the intersection of the existing galleries and the newly designed bark line. Further down the line BWW are fed to the bunker of boiler No.5 by belt conveyors via existing galleries. The stretch of galleries from the discharge and mixing shed to the chemical water treatment plant of CHPP-1 is subject to reconstruction.

The throughput capacity of the bark and sawdust conveyors is 300 bulk m<sup>3</sup>/h.

The project also envisages complete mechanization of BWW preparation and transportation processes, which narrows the staff's job down to general supervision of machines and mechanisms operation. Automation systems are designed on the basis of Russian standard elements of remote control and automation.

The sources of additional wood and bark wastes are sawmills of Solombala-Maimaksa Industrial Hub of Arkhangelsk located in the vicinity of the Mill.

### **Installation of electrostatic precipitator**

Combustion of BWW in fluidized bed leads to increase in emissions of fly ash and inert material with flue gases, therefore the boiler was fitted with ash collecting equipment. The originally installed wet flue gas treatment system relied on emulsifiers. The emulsifier-based gas treatment system was selected because of its relative cheapness (compared to electrostatic precipitator), and also because it ensured simultaneous desulfurization of the flue gas (up to 30% of SO<sub>2</sub> removed) due to some SO<sub>2</sub> being diluted in water and tied in by carbonate compounds contained in ash.

However, further operation of the retrofitted boiler showed that the emulsifier did not ensure its nameplate ash collection efficiency which led to clogging of the boiler's flue gas ducts at the inlet to the emulsifier, at the inlet to and at the outlet from the induced draft fan, guide vanes of the induced draft fan and its impeller, which resulted in shorter intervals between scheduled maintenance of the boiler, as well as in wear and tear of the gas ducts and of the rear equipment the boiler. The boiler would operate normally for no longer than 15 days before its steam output would start to go down due to draught loss.

The modernization of the gas treatment system, which was carried out shortly afterwards and connected multicyclone ash collectors (BCU 200/176) in parallel operation with the emulsifier, did not help to keep within the prescribed BWW fly ash emission standard.

In 2007 the wet flue gas treatment system based on emulsifier was entirely replaced with an electrostatic precipitator of EGU 105-21-12-9WS640-400-1 type, which reduced the ash content in treated flue gases down to 100 mg/Nm<sup>3</sup>, increased the normal operation time of the boiler up to 30 days and increased the steam output (by reducing the airflow resistance of the gas treatment unit) up to 60, 70 and 90 tonnes of steam per hour when firing BWW with as-received moisture content of 65, 60, 57%, respectively,



without flame stabilization with the help of heavy fuel oil. The supplier of the electrostatic precipitator is LLC “Energomashtekhnologia”.

It should be noted that installation of an electrostatic precipitator did not have any impact whatsoever on the amount of generated GHG emission reductions under the project, however it mitigated emissions of pollutants into the atmosphere.

### **Actual timeframe of implementation of the project components**

As of today all of the project solutions are implemented.

Construction and installation works related to replacement of boiler No.5, including its dismantling and installation of a wet flue gas treatment system, were carried out from May 2001 to February 2003. The test run of the replaced boiler was made in December 2002. The official acceptance of work took place on June 30, 2003 [R16].

Construction and installation works related to BWB handling, preparation and feeding facility were carried out from June 2003 to August 2004. The official acceptance of work took place on September 30, 2004 [R17].

Construction and installation works related to installation of the electrostatic precipitator were carried out from November 2006 to August 2007. The official acceptance of the electrostatic precipitator for operation took place on December 29, 2007 [R18].

<p><b>A.4.3. Brief explanation of how the anthropogenic emissions of greenhouse gases by sources are to be reduced by the proposed JI project, including why the emission reductions would not occur in the absence of the proposed project, taking into account national and/or sectoral policies and circumstances:</b></p>
---

Combustion of fossil fuel leads to significant emissions of greenhouse gases (GHG). The primary greenhouse gas from fossil fuel combustion is CO<sub>2</sub>. Emissions of N<sub>2</sub>O and CH<sub>4</sub> from combustion are negligible compared to emissions of CO<sub>2</sub>. Emissions of CO<sub>2</sub> from biomass combustion are regarded as climatically neutral and are, therefore, assumed equal to zero. Decomposition of biomass at dumps in anaerobic conditions releases CH<sub>4</sub>. CH<sub>4</sub> emissions in CO<sub>2</sub> equivalent may be very high.

GHG emission reductions as a result of the project at Solomabla PPM are achieved due to reduction of fossil fuel (coal and heavy fuel oil) consumption and due to prevention of methane emissions into the atmosphere from anaerobic decomposition of BWB at dumps. This became possible due to retrofitting of OJSC “Solombala PPM” energy-generating system through implementation of modern BWB utilization technologies for energy generation, which enabled bark combustion and ensured increase in volume and efficiency of sawdust and chip screenings combustion.

Although the project includes replacement of a heavy fuel oil boiler with a BWB-fired boiler, the project results in approximately proportional reduction in coal and heavy fuel oil consumption. This is explained by the fact that the enterprise trying to load its BWB boilers to the maximum uses coal-fired boilers for production of major portion of heat, whereas heavy fuel oil is used as a back-up fuel as well as for lighting up boilers, flame stabilization during BWB combustion and also in heavy fuel oil fired boilers which are operated to cover the peak loads. The project implementation leads to increase in the amount of heat produced from BWB and to almost proportional decrease in the amount of energy produced from heavy fuel oil and coal.

In the absence of the project the said GHG emission reductions would not have been achieved because the existing utilizing boiler No.1 is not technically suitable for bark combustion and its sawdust and chip screenings firing capacity is limited. The energy demand would have been covered mainly by fossil fuel combustion and the surplus BWB generated both at Solombala PPM and at the neighbouring enterprises would have been disposed at the dumps.



It is unlikely that the project would have been implemented in the absence of the joint implementation mechanism taking into account the following:

- Technical condition of the old utilizing boiler No.1 allowed to operate it at the same level for another number of years and to utilize around 100 thousand dense m<sup>3</sup> of sawdust and chip screenings per year, which is also demonstrated by the fact that even after boiler No.5 was switched to BWW combustion, boiler No.1 still continued its operation, firing sawdust and chip screenings;
- Technical condition of heavy fuel oil boiler No.5 allowed to operate it at the same level for a number of years which is also confirmed by the fact that boiler No.4 which was installed the same year is still in operation;
- The required steam can be always produced in CHPP-1 by firing additional quantities of heavy fuel oil and coal in the existing boilers;
- The project requires large investments and the return on investments for this project in the absence of additional revenues from selling GHG emission reductions is not sufficiently high;
- The project implementation involves a fairly new technology of fluidized bed combustion of BWW with which SPPM has had no experience whatsoever;
- There are no caps on GHG emissions for companies in Russia;
- It is not expected that there will be any significant changes in the Russian environmental legislation, which might force the company to stop operating the equipment which existed prior the project and to discontinue BWW dumping;
- Prior to the project implementation SPPM disposed BWW on the territory adjacent to the Mill, there were no obstacles that could impede this practice. Reduction in environmental payments would not have any significant effect upon the project economics.

In the absence of the project it would have been possible to avoid investment and technological risks.

**Investment risks** mean that in reality the project implementation could have required more investments than it was originally planned. This might have happened because of design errors, need to purchase additional equipment, need to carry out unplanned works, raise in prices for equipment, installation and set up works, etc. Which, in fact, did happen in case of this project. Actual investment costs turned out to be 1.95 times higher than the estimated level.

The high opportunity cost of capital is also worth mentioning. Investments in modernization and expansion of main production capacities, including introduction of up-to-date energy saving technologies, might have brought more profit to the project owners than investments in construction of additional BWW utilization capacities.

### **Technological risks**

Fluidized bed combustion of BWW is a complex technology. A lot of requirements set to organization of air feeding process, particle size distribution of the bed material and fuel characteristic have to be met to organize sustainable fuel combustion and to maintain performance efficiency of a fluidized bed.

Bark and wood wastes are classified as a difficult-to-burn fuel because of their non-uniform fractional composition and high moisture content. The particle size distribution of BWW must be optimum for a given furnace configuration. Any deviation of the particle size from the optimum level both towards the higher and the lower end of the range impairs the boiler performance. Very small particles can fall through the air-distributing grate or be carried from the furnace with flue gases even before starting to burn. Large particles, on the other hand, can damage the fuel feed system and hinder normal operation of the fluidized bed. Therefore in order to ensure sustainable BWW combustion it is crucial to build a BWW preparation facility, in which one of the most important elements would be the bark crusher.



The main fuel fired in boiler No.5 is bark. The high moisture content (moisture content of bark may reach up to 70%) reduces the calorific value of BWW mixture, adiabatic burning temperature, burning process stability and, finally, the performance efficiency of the boiler in general.

Boiler No.1 of CKTI-40-34x2 type cannot be used for bark utilization because the moisture and tar content of bark make it unsuitable for combustion in this type of boilers.

BWW fluidized bed combustion technologies, which do not rely on adding fossil fuel for flame stabilization, were hardly ever deployed in Russia in 2000 and were very poorly mastered. Boilers using fluidized bed technology had never before been built and operated at SPPM.

Therefore, from the technological point of view, this project was a serious challenge for the company, because any violation of the described above processes and requirements could cause breakdown of the equipment or decrease in its operating life, besides it could cause increase in repair and maintenance expenses.

SPPM had to overcome certain difficulties not only at the stage of equipment installation but also during operation of the boiler equipment. It was necessary to recruit, train and ensure certification of operational staff for boiler No.5, which took time and entailed certain costs. Furthermore, operation of equipment and technology of such level requires that the personnel (workers, engineers and managers) should have a high level of motivation skills and knowledge. It should be also noted that high moisture content and low calorific value of bark are a serious problem which has to be constantly attended to by the maintenance personnel.

To mitigate the said risks and to increase financial profitability of the project the company management has been and is still trying to sell emission reduction units (ERUs), as well as early emission reductions achieved before 2008. This issue was discussed with the Environmental Investments Center, NPAF ED, Camco International and, finally, with CCGS LLC, which was selected as a partner for preparation of the required project design documentation and selling GHG emission reductions in the global market.

#### **A.4.3.1. Estimated amount of emission reductions over the crediting period:**

	Years
Length of the <u>crediting period</u>	5
Year	Estimation of annual emission reductions in tonnes of CO <sub>2</sub> equivalent
2008	227 537
2009	198 292
2010	271 037
2011	289 990
2012	308 088
Total estimated emission reductions over the <u>crediting period</u> (tonnes of CO <sub>2</sub> equivalent)	1 294 943
Annual average of estimated emission reductions over the <u>crediting period</u> (tonnes of CO <sub>2</sub> equivalent)	258 989

#### **A.5. Project approval by the Parties involved:**

The Letters of Approval will be obtained later.



**SECTION B. Baseline****B.1. Description and justification of the baseline chosen:****Selection of the approach to baseline setting**

In setting the baseline the PDD developer used JI specific approach based on paragraph 9 (a) of the “Guidance on criteria for baseline setting and monitoring” [R1].

The baseline was set in accordance with Annex B of the JI Guidelines<sup>3</sup>. The justification of the baseline was elaborated in accordance with paragraphs 23-29 of the “Guidance on criteria for baseline setting and monitoring”.

First of all, the most likely baseline scenario was selected based on the analysis of several BWW handling and heat production alternatives within the framework of this project. Selection of the baseline was justified taking into account Annex 1 to the “Guidance on criteria for baseline setting and monitoring”.

The special feature of this project is that the construction and installation works have been completed to date and the project is a reality and is right now generating physical reductions of GHG emissions. Therefore, it is reasonable to determine specific baseline parameters affecting the projected level of GHG emission reductions till the end of 2012, taking into account not only historical data recorded prior to the project commencement (2000-2002) but also the accumulated actual project data (2003-2009).

All key data, factors and assumptions affecting GHG emission reductions are considered on a transparent and conservative basis.

**Identification of the likely future scenarios and selection of the baseline scenario**

The groups of alternative options for the following two types of project activity were considered separately:

- Handling of surplus BWW (the volume of which is equal to the increase in BWW combustion in CHPP-1 as a result of the project);
- Production of the required amount of heat (steam) for the Mill (which is equal to the quantity of steam produced in CHPP-1 due to increase in the volume and efficiency of BWW combustion as a result of the project).

The following alternatives of surplus BWW handling were identified:

- Alternative W1. Continuation of the current situation;
- Alternative W2. Use of BWW as fuel for heat and power generation at Arkhangelsk CHPP;
- Alternative W3. Use of BWW as feedstock for the Hydrolysis Plant;
- Alternative W4. Project activity without joint implementation mechanism.

The following alternatives covering generation of the required amount of heat (steam) for the Mill were identified:

- Alternative H1. Continuation of the current situation;
- Alternative H2. Reduction in coal and residual fuel oil consumption by CHPP-1 and purchase of the required amount of heat from external suppliers;
- Alternative H3. Installation of a new coal-fired boiler in CHPP-1;

---

<sup>3</sup> Annex *Decision 9/CMP.1* (known as the JI Guidelines) includes *Appendix B*, which lays out criteria for baseline setting and monitoring.



Alternative H4. Switching CHPP-1 to natural gas;

Alternative H5. Project activity without joint implementation mechanism.

The analysis of each alternative is given below.

### **Handling of surplus BWW**

#### Alternative W1. Continuation of the current situation

This alternative assumes continuation of the situation that took place prior to the project when only limited quantities of sawdust and screenings were fired in utilizing boiler No.1 of SPPM's CHPP-1 with addition of heavy fuel oil for flame stabilization, while combustion of bark was not technically possible.

All bark and surplus wood wastes would have been dumped as is common practice for OJSC "Solombala PPM" and other enterprises of wood working industry in Arkhangelsk and in Russia in general. Dumps cover extensive areas and are very high. This practice does not violate the current Russian legislation. To date there have been no problems with dumping of unclaimed wood wastes and neither are such problems anticipated in the future.

This scenario does not involve any investments and additional operational costs related to construction and operation of sophisticated BWW utilization equipment for energy generation purposes, which makes it possible to spend investment resources on modernization and expansion of SPPM's core production capacities.

*Alternative W1 is quite realistic and can be considered as the most likely scenario of surplus BWW handling.*

#### Alternative W2. Use of BWW as fuel for heat and power generation at Arkhangelsk CHPP

Arkhangelsk has a district heating system based on co-generation of heat and power. The center of energy supply is Arkhangelsk CHPP running on heavy fuel oil. The boilers of Arkhangelsk CHPP are not designed for combustion of solid fuels and therefore combustion of BWW in them is not technically feasible. *Therefore, this alternative was dismissed.*

#### Alternative W3. Use of BWW as feedstock for the Hydrolysis plant

Indeed, wood wastes can be used by hydrolysis plants as a feedstock for alcohol production. Arkhangelsk hydrolysis plant (AHP) is located not far from SPPM. However since 1995 alcohol production from wood was discontinued at AHP. Alcohol production at the plant switched to molasses, beet sugar production residue, and later on – to sulphite liquors. Currently the plant is barely operational. *Thus, this alternative was also excluded from consideration.*

#### Alternative W4. Project activity without joint implementation mechanism

This alternative would have resulted in the Mill having capacities for combustion of bark and surplus wood wastes (sawdust and chip screenings) produced at the Mill and supplied from the outside, thereby their dumping would have been prevented.

However this project alternative encounters some serious problems (See the Investment analysis in Section B.2). The project implementation involves risks and significant investments, whereas economic parameters of the project without additional revenues from sale of emission reductions are unacceptably low. Construction and operation of a fluidized bed boiler and auxiliary fuel preparation equipment is not a widely used practice at Russian pulp and paper mills.

*Alternative W4 could hardly have been implemented without the joint implementation mechanism.*



## **Production of the required amount of heat (steam) for the Mill**

### Alternative H1. Continuation of the current situation

Technical condition of utilizing boiler No.1 allows to keep its operation for another number of years by giving it relatively inexpensive routine maintenance. Most of heat (fresh steam) in CHPP-1 is produced by heavy fuel oil and coal-fired boilers. Technical condition of these boilers does not cause any concern and their capacities can be used without any constraints. The total capacity of the boilers is sufficient to produce the required quantity of steam. Continuation of the current situation does not involve significant and risky capital expenditure.

*Alternative H1 is the less risky scenario for the company and can be considered as a highly likely baseline scenario for production of the required amount of heat for the Mill.*

### Alternative H2. Reduction in coal and heavy fuel oil consumption by CHPP-1 and purchase of the lacking amount of heat from external suppliers

The only major supplier of heat – Arkhangelsk CHPP – is located in the relative vicinity of SPPM. This CHPP used to supply low-pressure steam (not more than 6 atm) to the Mill. However already in the 1990-s steam supplies were discontinued, mainly, for economic reasons, and the low-pressure steam pipeline that connected SPPM and Arkhangelsk CHPP was decommissioned. Steam purchase from the outside leads to ousting of steam extraction from the Mill's own turbines and reducing in-house power production in co-generation mode. It's beyond reason to expect that steam supplies from the outside will be resumed because reduction in steam production by the Mill's own capacities and purchase of steam from the outside are at the present moment a knowingly uneconomic option for SPPM.

It should be also noted that the Mill needs not only low pressure process steam but also steam with higher pressure parameters. And for charging the steam turbines, the Mill needs fresh steam with parameters which are ensured by the existing CHPP-1 boilers of SPPM (nominal steam parameters: temperature 440 °C, pressure 3.9 MPa). The higher steam parameters and longer the transportation distance, the greater are the technological challenges and constraints, say nothing of the cost of construction and operation of the steam main.

*Therefore this alternative was dismissed.*

### Alternative H3. Installation of a new coal-fired boiler in CHPP-1

This alternative envisages replacement and switching of heavy fuel oil boiler No.5 (or No.4) to coal.

As compared to heavy fuel oil, coal is a less “easy-to-handle” fuel which requires higher energy consumption and entails other costs related to preparation of fuel for combustion. Moreover, coal boilers are more complicated in operation. Steam output can be better controlled and the peak load handled more efficiently in heavy fuel oil boilers. Coal boilers, on the contrary, are not that dynamic. Furthermore, the Mill seeks to mitigate the risks and avoid relying on any particular type of fuel. Significant growth of coal consumption could considerably increase the Mill's negative environmental impact, which is contrary to the company's environmental policy<sup>4</sup>. *Thus, this alternative is very unlikely.*

### Alternative H4. Switching CHPP-1 to natural gas

At the time when the decision to implement the project was taken (2000) this alternative seemed to be a very far opportunity, because Arkhangelsk did not have access to natural gas. However as of today in view of completion of “Nuksenitsa-Arkhangelsk” gas main, the potential connection of major consumers (TGC-2, Arkhangelsk and Solombala PPMs) to gas is being widely discussed.

Since natural gas is now available in Arkhangelsk, Solombala PPM is considering the possibility of switching some of its own facilities, CHPP-1 in particular, to natural gas. It is planned to use natural gas

---

<sup>4</sup> [http://www.solombala.com/sppm/ecology/eco\\_polotika/](http://www.solombala.com/sppm/ecology/eco_polotika/)



for lighting up and flame stabilization in boilers No.1 and 5 (firing BWW), in coal-fired boilers No.2 and 3, and to switch boiler No.4 completely to natural gas.

There are plans but the decision to commence works that would provide gas supply has not been taken so far, the reason being that the project financing has not been settled yet. According to the company's latest projections, gas supply of the Mill should not be expected before the year 2013.

The situation is made even more complicated by the fact that in order to supply gas to the Mill it would be necessary to build a fairly lengthy stretch of gas distribution pipeline. SPPM will have to build it with its own money. According to the preliminary estimations, ensuring gas supply to the Mill may cost around RUR 170 million. It is most likely that the Mill will need a loan.

Moreover, natural gas prices in Russia, including the Arkhangelsk Region, are likely to grow<sup>5</sup> at a rate outstripping other fuels and the cost-effectiveness of "switch to natural gas" projects will decrease. Due to these and other factors provision of gas supply to the Mill may soon become a quite unappealing option without it being submitted as a GHG emission reduction project. It's true that at the present moment there are a lot of uncertainties regarding carbon projects implementation after 2012, but there are chances. In principle, emission reductions could be sold within the framework of the prolonged Kyoto Protocol or within the framework of any voluntary standard, or if the project is implemented under the green investments scheme.

*Thus, switching of CHPP-1 to natural gas may not be considered as an alternative to the project activity.*

#### Alternative H5. Project activity without joint implementation mechanism

Implementation of this alternative makes it possible to ensure the Mill with the required heat and enables boiler No.5 to fire bark, as well as the remaining sawdust and chip screenings produced at SPPM and neighbouring enterprises. This will enable reduction of fossil fuel (heavy fuel oil and coal) consumption.

However, according to what was stated above for Alternative W4, *this option could hardly have been implemented without the joint implementation mechanism.*

***Thus, based on the above analysis of alternatives and with allowance for the results of the investment analysis given further in the text, the following two alternatives were selected as the most likely baseline scenarios, each of them assuming continuation of the current situation: Alternative W1, which envisages further dumping of surplus BWW, and Alternative H1, which envisages production of the required amount of heat for the Mill from heavy fuel oil and coal.***

#### **Justification and description of the methodology for estimation of GHG emissions**

When initially reviewed the following emission sources were included within the project boundaries:

For the baseline scenario:

- heat production in CHPP-1, CO<sub>2</sub> emissions from combustion of coal and heavy fuel;
- BWW dumping sites, avoided (due to the project) CH<sub>4</sub> emissions from anaerobic decomposition of BWW.

For the project scenario:

- heat production in CHPP-1, CO<sub>2</sub> emissions from combustion of coal and heavy fuel;
- combustion of additional quantity of BWW (compared to the baseline scenario), N<sub>2</sub>O and CH<sub>4</sub> emissions from combustion of BWW.

---

<sup>5</sup> See, for example, the report of the Deputy Head of the Federal Tariff Service of Russia of 08.07.2010, which mentions a step-wise increase in wholesale gas prices until they reach the level which ensures equal profitability of gas supply to the international and domestic markets.

[http://www.fstrf.ru/press/meeting/28/1\)\\_Pomchalovoj\\_E.V.\\_Doklad\\_PomchalovojE.V..ppt](http://www.fstrf.ru/press/meeting/28/1)_Pomchalovoj_E.V._Doklad_PomchalovojE.V..ppt)

Leakages which take place due to the project include:

- fugitive emissions of CH<sub>4</sub> from production, processing, storage, handling and distribution of fossil fuels used by transport vehicles and energy sources of the Mill;
- transportation of additional quantity of BWW to the Mill for combustion (compared to the baseline scenario), CO<sub>2</sub> emissions from combustion of fossil fuel;
- additional energy consumption for fuel preparation under the project (compared to the baseline scenario), energy consumption and related CO<sub>2</sub> emissions.

### GHG emission reductions

In general case, GHG emission reductions during the year  $y$  are calculated as follows, tCO<sub>2</sub>e:

$$ER_y = BE_y - PE_y - LE_y, \quad (B.1-1)$$

where  $BE_y$  is the baseline GHG emissions during the year  $y$ , tCO<sub>2</sub>e;

$PE_y$  is the project GHG emissions during the year  $y$ , tCO<sub>2</sub>e;

$LE_y$  is the leakages due to the project activity during the year  $y$ , tCO<sub>2</sub>e.

### Baseline GHG emissions

In accordance with the above specified sources, in general case, the baseline GHG emissions during the year  $y$  are calculated by the following formula, tCO<sub>2</sub>e:

$$BE_y = BE_{coal,y} + BE_{fuel\ oil,y} + BE_{bark,y} + BE_{sd+spw,y}, \quad (B.1-2)$$

where  $BE_{coal,y}$  is the baseline CO<sub>2</sub> emissions due to combustion<sup>6</sup> of coal in CHPP-1 during the year  $y$ , tCO<sub>2</sub>e;

$BE_{fuel\ oil,y}$  is the baseline CO<sub>2</sub> emissions due to combustion of heavy fuel oil in CHPP-1 during the year  $y$ , tCO<sub>2</sub>e;

$BE_{bark,y}$  is the avoided (due to the project) emissions of CH<sub>4</sub> from decomposition of bark at dumps during the year  $y$ , tCO<sub>2</sub>e;

$BE_{sd+spw,y}$  is the avoided (due to the project) emissions of CH<sub>4</sub> from decomposition of sawdust and chip screenings at dumps during the year  $y$ , tCO<sub>2</sub>e;

The baseline CO<sub>2</sub> emissions due to combustion of coal in CHPP-1 during the year  $y$  are calculated by the following formula, tCO<sub>2</sub>e:

$$BE_{coal,y} = FC_{coal,BL,y} \times EF_{CO_2,coal}, \quad (B.1-3)$$

where  $FC_{coal,BL,y}$  is the baseline consumption of coal in CHPP-1 during the year  $y$ , GJ;

$EF_{CO_2,coal}$  is the CO<sub>2</sub> emission factor for coal, tCO<sub>2</sub>/GJ.

The baseline CO<sub>2</sub> emissions due to combustion of heavy fuel oil in CHPP-1 during the year  $y$  are calculated by the following formula, tCO<sub>2</sub>e:

$$BE_{fuel\ oil,y} = FC_{fuel\ oil,BL,y} \times EF_{CO_2,fuel\ oil}, \quad (B.1-4)$$

---

<sup>6</sup> Emissions of CH<sub>4</sub> and N<sub>2</sub>O as a result of fossil fuel combustion are considered to be negligible compared to the emissions of CO<sub>2</sub> and were not considered in the PDD

where  $FC_{fuel\ oil, BL, y}$  is the baseline consumption of heavy fuel oil in CHPP-1 during the year  $y$ , GJ;

$EF_{CO_2, fuel\ oil}$  is the  $CO_2$  emission factor for heavy fuel oil,  $tCO_2/GJ$ .

The  $CO_2$  emission factors for coal and heavy fuel oil are assumed in accordance with the IPCC Guidelines [R5] to be constant over years and numerically equal to  $EF_{CO_2, coal} = 0.0946\ tCO_2/GJ$  and  $EF_{CO_2, fuel\ oil} = 0.0774\ tCO_2/GJ$ , respectively. The methodology for calculation of fuel consumption is given below.

For the sake of simplicity, when the GHG emission reduction calculation methodology is described the values of coal and heavy fuel oil consumption under the baseline and project scenarios are given in energy units (GJ).

The numerical estimations of avoided  $CH_4$  emissions from decomposition of BWW at dumps ( $BE_{bark, y}$  and  $BE_{sd+spw, y}$ ) were made using the model “Calculation of  $CO_2$ -equivalent emission reductions from biomass prevented from stockpiling or taken from stockpiles” developed by BTG biomass technology group B.V. for the World Bank [R2]. The model is built on the First Order Decay method with experimental adjustment of a number of parameters to waste wood dumps.

In this model most of the parameters are constants and are determined once at the stage of the PDD development. The parameters variable from year to year are the volumes of BWW (bark, sawdust and chip screenings), which are prevented from dumping due to the project activity starting from the year 2003 (the first year of operation of replaced boiler No.5). Instead of being disposed at the dump this quantity of BWW is utilized as fuel in CHPP-1 under the project.

In accordance with [R2] the formulae for calculation of prevented methane emissions are as follows:

$$BE_{bark, y} = \left(1 - w_{lignin, BWW}\right) \times k_{BWW} \times \frac{C_{BWW}^d}{100} \times \left(1 - \frac{M_{bark}}{100}\right) \times a \times \zeta \times \left(1 - \frac{\varphi}{100}\right) \times \left(1 - \zeta_{OX}\right) \times \frac{V_m}{100} \times \rho_{CH_4} \times GWP_{CH_4} \times \sum_{x=2003}^{x=y} \left(W_{bark, x} \times e^{-k_{BWW} \times (y-x)}\right), \quad (B.1-5)$$

$$BE_{sd+spw, y} = \left(1 - w_{lignin, BWW}\right) \times k_{BWW} \times \frac{C_{BWW}^d}{100} \times \left(1 - \frac{M_{sd+spw}}{100}\right) \times a \times \zeta \times \left(1 - \frac{\varphi}{100}\right) \times \left(1 - \zeta_{OX}\right) \times \frac{V_m}{100} \times \rho_{CH_4} \times GWP_{CH_4} \times \sum_{x=2003}^{x=y} \left(W_{sd+spw, x} \times e^{-k_{BWW} \times (y-x)}\right), \quad (B.1-6)$$

where  $W_{bark, x}$  is the quantity of bark prevented from dumping as a result of the project during the year  $x$ , t;

$W_{sd+spw, x}$  is the quantity of sawdust and chip screenings prevented from dumping as a result of the project during the year  $x$ , t;

$M_{bark}$  is the moisture content of bark, %;

$M_{sd+spw, x}$  is the moisture content of sawdust and chip screenings, %;

$w_{lignin, BWW}$  is the lignin fraction of C for BWW;

$k_{BWW}$  is the decomposition rate constant for BWW,  $year^{-1}$ ;

$C_{BWW}^d$  is the organic carbon content in BWW on dry basis, %;

$a$  is the conversion factor from kg carbon to landfill gas quantity,  $m^3/kg$  carbon;

$\zeta$  is the generation factor;

$\phi$  is the percentage of the stockpile under aerobic conditions, %;

$\zeta_{OX}$  is the methane oxidation factor;

$V_m$  is the methane concentration biogas, %;

$\rho_{CH_4}$  is the density of methane,  $kg/m^3$ ;

$GWP_{CH_4}$  is the global warming potential of methane,  $tCO_2e/tCH_4$ ;

$y$  is the year for which to calculate the  $CO_2$ -equivalent reduction, year;

$x$  is the year in which fresh biomass is utilized instead of stockpiled, year.

*The quantity of bark prevented from dumping as a result of the project during the year  $x$ ,  $t$ :*

$$W_{bark,x} = FC_{bark,PJ,x}^v \times \frac{\rho_{bark}}{1000} \quad (B.1-7)$$

where  $FC_{bark,PJ,x}^v$  is the volumetric consumption of bark in CHPP-1 under the project during the year  $x$ , dense  $m^3$ ;

$\rho_{bark}$  is the density of moist bark,  $kg/dense\ m^3$ .

The density of moist bark (for pine with moisture content over 23%) is calculated as per the methodology given in [R4] by the following formula,  $kg/dense\ m^3$ :

$$\rho_{bark} = \frac{100}{1.231 \times (100 - M_{bark})} \times \rho_{12,bark} \quad (B.1-8)$$

where  $\rho_{12,bark}$  is the bark density at standard moisture content (i.e. at absolute density of 12%),  $kg/dense\ m^3$ .

In accordance with [R4] the bark density at standard moisture content is assumed equal to  $\rho_{12,bark} = 680$   $kg/dense\ m^3$  (for pine).

*The quantity of sawdust and chip screenings prevented from dumping as a result of the project during the year  $x$ ,  $t$ :*

$$W_{sd+spw,x} = (FC_{sd+spw,PJ,x}^v - FC_{sd+spw,BL,x}^v) \times \frac{\rho_{sd+spw}}{1000} \quad (B.1-9)$$

where  $FC_{sd+spw,PJ,x}^v$  is the project volumetric consumption of sawdust and chip screenings in CHPP-1 during the year  $x$ , dense  $m^3$ ;

$FC_{sd+spw,BL,x}^v$  is the baseline volumetric consumption of sawdust and chip screenings in CHPP-1 during the year  $x$ , dense  $m^3$ ;

$\rho_{sd+spw}$  is the density of moist sawdust and chip screenings,  $kg/dense\ m^3$ .





The density of moist sawdust and chip screenings (for pine with moisture content over 23%) is calculated in accordance with the methodology given in [R4] by the following formula, kg/dense m<sup>3</sup>:

$$\rho_{sd+spw} = 0.823 \times \frac{100}{100 - M_{sd+spw}} \times \rho_{12, sd+spw} \quad (\text{B.1-10})$$

where  $\rho_{12, sd+spw}$  is the density of sawdust and chip screenings at standard moisture content (i.e. at absolute moisture content of 12%), kg/dense m<sup>3</sup>.

In accordance with [R4] the density of sawdust and chip screenings at standard moisture content is assumed equal to  $\rho_{12, sd+spw} = 500$  kg/dense m<sup>3</sup> (for pine).

*Moisture content.* For bark, sawdust and chip screenings we assumed default values recommended by [R2]:  $M_{bark,x} = 50\%$ ;  $M_{sd+spw,x} = 50\%$ . It is important to note that carbon content in a dense BWW volume does not depend on BWW moisture and in this case moisture content does not affect estimation of stockpile methane emissions.

*Lignin fraction of C.* The default value recommended by [R2] was assumed:  $w_{lignin,BWW} = 0.25$ .

*Decomposition rate constant.* The default value recommended by [R2] was assumed:  $k_{BWW} = -\ln(1/2)/15 = 0.046$  year<sup>-1</sup>, where 15 is the recommended default half-life value for wood, years.

*Organic carbon content on dry basis.* The default value recommended by [R2] was assumed:  $C_{BWW}^d = 53.6\%$ .

*Conversion factor from kg carbon to landfill gas quantity.* The default value recommended by [R2] was assumed:  $a = 22.4/12 = 1.87$  m<sup>3</sup>/kg carbon, where 22.4 is the molar volume of gas at standard conditions, l/mol; 12 is the molar mass of C, g/mol.

*Generation factor.* The default value recommended by [R2] was assumed:  $\zeta = 0.77$ .

*Percentage of the stockpile under aerobic conditions.* The default value recommended by [R2] was assumed:  $\varphi = 10\%$ .

*Methane oxidation factor.* The default value recommended by [R2] was assumed:  $\zeta_{OX} = 0.10$ .

*Methane concentration in biogas.* The default value recommended by [R2] is:  $V_m = 60\%$ . We assumed a more conservative value  $V_m = 50\%$ .

*Methane density.* In accordance with [R2] it was assumed:  $\rho_{CH_4} = 16.04/22.4 = 0.716$  kg/m<sup>3</sup>, where 16.04 is the molar mass of CH<sub>4</sub>, g/mol, 22.4 is the molar volume of gas at standard conditions, l/mol.

*Global warming potential of methane.* In accordance with [R2]:  $GWP_{CH_4} = 21$  tCO<sub>2</sub>e/tCH<sub>4</sub>.

*Year for which to calculate the CO<sub>2</sub>-equivalent reduction.* Here:  $y = 2008-2012$ .

*Year in which fresh biomass is utilized instead of stockpiled.* Starting with the first year of operation of replaced boiler No.5, when the quantity of utilized BWW under the project exceeded the quantity of utilized BWW under the baseline scenario:  $x = 2003-2012$ .

Ultimately, baseline GHG emissions include only CO<sub>2</sub> emissions from heavy fuel oil and coal combustion in CHPP-1, as well as prevented CH<sub>4</sub> emissions from decomposition of bark, sawdust and chip screenings at dumps:



$$BE_y = BE_{coal,y} + BE_{fuel\ oil,y} + BE_{bark,y} + BE_{sd+spw,y} \quad (B.1-11)$$

### Heat production in CHPP-1 under the baseline scenario

In order to calculate consumption of coal and heavy fuel oil in CHPP-1 it is necessary to determine heat (fresh steam) production by CHPP-1 boilers.

The baseline scenario presupposes that heat is produced in CHPP-1 by the same equipment as prior to the project: boiler No.1 operates in the same mode firing sawdust and chip screenings; boilers No.2 and No.3 run on coal, boilers No.4 and No.5 – on heavy fuel oil. Bark and some sawdust and chip screenings are disposed to the dumps. Heavy fuel oil, apart from boilers No.4 and No.5, is also used as a backup fuel in all the other boilers.

It is assumed that under the baseline scenario CHPP-1 boilers would have produced as much heat as under the project, that is:

$$HG_{CHPP-1,BL,y} = HG_{CHPP-1,PJ,y} \quad (B.1-12)$$

where  $HG_{CHPP-1,BL,y}$  is the total production of heat by CHPP-1 boilers under the baseline scenario during the year  $y$ , GJ;

$HG_{CHPP-1,PJ,y}$  is the total production of heat by CHPP-1 boilers under the project scenario during the year  $y$ , GJ.

Due to the peculiarities of the layout of the metering system at SPPM, fuel (coal, heavy fuel oil, BWW) consumption is directly monitored for CHPP-1 as a whole, without breakdown by boilers. Furthermore, the analysis of fuel consumption data (See Table B.1-1 and B.1-3) shows that the project implementation led to almost proportional reduction in consumption of coal and heavy fuel oil at CHPP-1 as a whole. This is explained by the fact that SPPM, trying to load its BWW boilers to the maximum, uses coal-fired boilers for production of major portion of heat, whereas heavy fuel oil is used as a back-up fuel as well as for lighting up boilers, flame stabilization during BWW combustion and also in heavy fuel oil fired boilers which are operated to cover peak loads. The project implementation leads to increase in the amount of heat produced from BWW and to almost proportional decrease in the amount of energy produced from heavy fuel oil and coal.

Therefore it is reasonable to include the whole of CHPP-1 in the project and baseline boundaries.

This being said, the total heat production in CHPP-1 under the baseline scenario can be presented as follows:

$$HG_{CHPP-1,BL,y} = HG_{1,sd+spw,BL,y} + HG_{coal,BL,y} + HG_{fuel\ oil,BL,y} \quad (B.1-13)$$

where  $HG_{1,sd+spw,BL,y}$  is the baseline heat production by boiler No.1 from sawdust and chip screenings during the year  $y$ , GJ;

$HG_{coal,BL,y}$  is the baseline heat production at CHPP-1 from coal during the year  $y$ , GJ;

$HG_{fuel\ oil,BL,y}$  is the baseline heat production in CHPP-1 from heavy fuel oil during the year  $y$ , GJ.

The baseline heat production by boiler No.1 from sawdust and chip screenings is determined following the conservative approach as the lowest of the two values:

- 1) maximum technically possible quantity of heat that can be produced by boiler No.1 from wood wastes;
- 2) quantity of heat that could be produced by this boiler by means of firing the entire volume of sawdust and chip screenings which were fired during this  $y$  under the project (under the project

combustion takes place in boilers No.1 and No.5) with maximum efficiency of boiler No.1 (specific production) that was recorded during three years before commissioning of replaced boiler No.5. This condition was included in the model in order to prevent negative emission reductions in case of decline in production.

That is:

$$HG_{1, sd+spw, BL, y} = MIN \left\{ \frac{SG_1^{nom} \times T_1^{max} \times (h_s - h_{FW})}{1000} \times (1 - f_1^{min}); FC_{sd+spw, PJ, y}^v \times SHG_{sd+spw}^{max} \right\}, \quad (B.1-14)$$

where  $SG_1^{nom}$  is the nominal steam output of boiler No.1, tonnes of steam per hour;

$T_1^{max}$  is the maximum annual number of running hours of boiler No.1, h;

$h_s$  is the heat content of fresh steam at nominal parameters, kJ/kg;

$h_{FW}$  is the heat content of feed water at nominal parameters, kJ/kg;

$f_1^{min}$  is the minimum proportion of heavy fuel oil for flame stabilization in boiler No.1;

$FC_{sd+spw, PJ, y}^v$  is the volumetric consumption of sawdust and chip screenings in CHPP-1 under the project during the year  $y$ , dense  $m^3$ ;

$SHG_{sd+spw}^{max}$  is the maximum average annual specific production of heat from sawdust and chip screenings in CHPP-1 that was recorded during three years before commissioning of replaced boiler No.5, GJ/dense  $m^3$ .

The nominal steam output of boiler No.1 amounts to  $SG_1^{nom} = 40$  tonnes of steam per hour.

In accordance with boiler No.1 operation data for the period 2000-2009, the maximum annual number of running hours of the boiler was assumed equal to  $T_1^{max} = 8100$  h.

The heat content was determined based on nominal parameters of steam and feed water assumed as per GOST standard 3619-89 [R20]: pressure 3.9 MPa, steam temperature 440°C, feed water temperature 145°C. The values of heat content of steam and feed water amount to  $h_s = 3309$  kJ/kg and  $h_{FW} = 612$  kJ/kg, respectively.

In order to ensure sustainable combustion of sawdust and chip screenings in boiler No.1 it is necessary to continuously feed heavy fuel oil to the boiler. Boiler No.1 doesn't have heavy fuel oil flow meters; however, according to operational data even at a minimum injection of heavy fuel oil to the boiler its flow rate amounts to around 1 tonne per hour. The estimations show that in this case around 1/3 of the steam output in boiler No.1 is ensured by combustion of heavy fuel oil. From conservative point of view, the minimum proportion of heavy fuel oil for flame stabilization was assumed equal to  $f_1^{min} = 0.25$ .

The value of  $SHG_{sd+spw}^{max}$  is determined as a maximum annual average value that was recorded during three full calendar years (2000-2002) before the official commissioning of replaced boiler No.5 (2003), GJ/dense  $m^3$ :

$$SHG_{sd+spw}^{max} = MAX \left\{ SHG_{sd+spw, 2000}; SHG_{sd+spw, 2001}; SHG_{sd+spw, 2002} \right\}. \quad (B.1-15)$$

The annual average specific production of heat from sawdust and chip screenings in CHPP-1 for the year  $y$  during 2000-2002, GJ/dense  $m^3$ :

$$SHG_{sd+spw, y} = \frac{HG_{sd+spw, y}}{FC_{sd+spw, y}^v}, \quad (B.1-16)$$

where  $HG_{sd+spw,y}$  is the heat production from sawdust and chip screenings in CHPP-1 during the year  $y$  during 2000-2002, GJ;

$FC_{sd+spw,y}^v$  is the volumetric consumption of sawdust and chip screenings in CHPP-1 during the year  $y$  in the period 2000-2002, dense  $m^3$ .

$$HG_{sd+spw,y} = \frac{FC_{sd+spw,y}^v \times NCV_{sd+spw}^{av} \times \eta_{sd+spw}}{FC_{fuel\ oil,y} \times \eta_{fuel\ oil} + FC_{coal,y} \times \eta_{coal} + FC_{sd+spw,y}^v \times NCV_{sd+spw}^{av} \times \eta_{sd+spw}} \times HG_{CHPP-1,y} \quad (B.1-17)$$

where  $HG_{CHPP-1,y}$  is the total production of heat by CHPP-1 boilers during the year  $y$  in the period 2000-2002, GJ;

$NCV_{sd+spw}^{av}$  is the average net calorific value of sawdust and chip screenings over the period 2000-2002, GJ/dense  $m^3$ ;

$FC_{fuel\ oil,y}$  is the consumption of heavy fuel oil in CHPP-1 during the year  $y$  in 2000-2002, GJ;

$FC_{coal,y}$  is the coal consumption in CHPP-1 during the year  $y$  in 2000-2002, GJ;

$\eta_{fuel\ oil}$  is the efficiency of heavy fuel oil combustion in CHPP-1 boilers;

$\eta_{coal}$  is the efficiency of coal combustion in CHPP-1 boilers;

$\eta_{sd+spw}$  is the efficiency of sawdust and chip screenings combustion in boiler No.1.

The efficiency of coal and heavy fuel oil combustion in CHPP-1 boilers is assumed in accordance with the recommendations [R6] for old heavy fuel oil fired and coal-fired boilers to be numerically equal to  $\eta_{fuel\ oil} = 0.85$  and  $\eta_{coal} = 0.8$ , respectively.

The efficiency of sawdust and chip screenings combustion in boiler No.1 is assumed equal to the efficiency of coal combustion in CHPP-1:  $\eta_{sd+spw} = 0.8$ . This assumption is conservative, because the efficiency of boiler No.1 with fuel-bed firing of wood wastes is knowingly lower than the efficiency of pulverized coal fired boilers with chamber furnaces that are installed in CHPP-1.

The average net calorific value of sawdust and chip screenings in 2000-2002, according to the reporting data of the company, amounted to  $NCV_{sd+spw}^{av} = 5.724$  GJ/dense  $m^3$ .

The maximum annual average specific heat production from sawdust and chip screenings in CHPP-1 in 2000-2002 was recorded in 2000 and amounted to  $SHG_{sd+spw}^{max} = 4.514$  GJ/dense  $m^3$ .

*Coal-based heat production in CHPP-1 under the baseline scenario* during the year  $y$ , GJ:

$$HG_{coal,BL,y} = FC_{coal,BL,y} \times \eta_{coal} \quad (B.1-18)$$

*Heat production in CHPP-1 from heavy fuel oil under the baseline scenario* during the year  $y$  is determined as the remainder, GJ:

$$HG_{fuel\ oil,BL,y} = HG_{CHPP-1,BL,y} - HG_{1,sd+spw,BL,y} - HG_{coal,BL,y} \quad (B.1-19)$$

The baseline data and calculation results for the period 2000-2002 are given in Table B.1-1 below.

**Table B.1-1. CHPP-1 operation data for the last three calendar years before the year of commissioning of replaced boiler No.5**

Parameter	Designation	Unit	2000	2001	2002
Total heat production by CHPP-1 boilers	$HG_{CHPP-1,y}$	GJ	3 075 770	2 932 227	3 353 887
Heavy fuel oil consumption	$FC_{fuel\ oil,y}$	GJ	1 879 123	1 616 476	2 010 813
		t	46 797	40 256	50 076
Coal consumption	$FC_{coal,y}$	GJ	<b>1 290 138</b>	1 424 378	1 411 071
		t	83 308	86 326	81 810
Bark consumption	$FC_{bark,y}^v$	dense m <sup>3</sup>	0	0	0
Saw dust and chip screenings consumption	$FC_{sd+spw,y}^v$	dense m <sup>3</sup>	107 136	106 533	127 826
Heat production from sawdust and chip screenings	$HG_{sd+spw,y}$	GJ	483 648	476 602	573 457
Specific heat production from sawdust and chip screenings	$SHG_{sd+spw,y}$	GJ/ dense m <sup>3</sup>	<b>4.514</b>	4.474	4.486
Proportion of heavy fuel oil consumption in total consumption of heavy fuel oil and coal	$\alpha_y$	GJ/GJ	<b>0.5929</b>	0.5316	0.5876

#### Fuel consumption in CHPP-1 under the baseline scenario

Coal, heavy fuel oil, sawdust and chip screenings are fired in CHPP-1 according to the baseline scenario. Since there is no possibility to fire bark and the capacity for combustion of sawdust and chip screenings is limited, all of bark and some quantity of sawdust and chip screenings are disposed at the dumps.

Coal consumption in CHPP-1 under the baseline scenario during the year  $y$  is determined following the conservative approach and proceeding from the conditions specified below, GJ:

$$FC_{coal,BL,y} = \text{MAX} \left\{ \text{MIN} [A; B; C; D]; E \right\}, \quad (\text{B.1-20})$$

where  $A$  is the coal consumption during the year  $y$  calculated on the assumption that consumption of heavy fuel oil in CHPP-1 under the baseline scenario is equal to consumption of heavy fuel oil under the project during the year  $y$ , GJ;

$B$  is the minimum annual coal consumption recorded in CHPP-1 during three years prior to commissioning of replaced boiler No.5, GJ;

$C$  is the coal consumption during the year  $y$  calculated on the assumption that average annual proportion of heavy fuel oil in the overall consumption of heavy fuel oil and coal in CHPP-1 under the baseline scenario is equal to maximum average annual proportion of heavy fuel oil recorded during three years prior to commissioning of replaced boiler No.5, GJ;

$D$  is the coal consumption during the year  $y$  calculated on the assumption that the average annual proportion of heavy fuel oil in the overall consumption of heavy fuel oil and coal in CHPP-1 under the baseline scenario is the same as under the project during the year  $y$ , GJ;

$E$  is the coal consumption in CHPP-1 under the project during the year  $y$ , GJ.

$$A = \left( HG_{CHPP-1,BL,y} - HG_{1,sd+spw,BL,y} - FC_{fuel\ oil,PJ,y} \times \eta_{fuel\ oil} \right) \times \frac{1}{\eta_{coal}}, \quad (\text{B.1-21})$$

$$B = FC_{coal}^{\min}, \quad (\text{B.1-22})$$

$$C = \left( HG_{CHPP-1,BL,y} - HG_{1,sd+spw,BL,y} - \frac{HG_{CHPP-1,BL,y} - HG_{1,sd+spw,BL,y}}{1 + \frac{1 - \alpha_{max}}{\alpha_{max}} \times \frac{\eta_{coal}}{\eta_{fuel\ oil}}} \right) \times \frac{1}{\eta_{coal}}, \quad (B.1-23)$$

$$D = \left( HG_{CHPP-1,BL,y} - HG_{1,sd+spw,BL,y} - \frac{HG_{CHPP-1,BL,y} - HG_{1,sd+spw,BL,y}}{1 + \frac{1 - \alpha_{PJ,y}}{\alpha_{PJ,y}} \times \frac{\eta_{coal}}{\eta_{fuel\ oil}}} \right) \times \frac{1}{\eta_{coal}}, \quad (B.1-24)$$

$$E = FC_{coal,PJ,y}, \quad (B.1-25)$$

where  $FC_{fuel\ oil,PJ,y}$  is the consumption of heavy fuel oil in CHPP-1 under the project during the year  $y$ , GJ;

$FC_{coal,PJ,y}$  is the coal consumption in CHPP-1 under the project during the year  $y$ , GJ;

$FC_{coal}^{min}$  is the minimum annual consumption of coal in CHPP-1 recorded during three years (2000-2002) prior to the commissioning of replaced boiler No.5, GJ;

$\alpha_{max}$  is the maximum value of heavy fuel oil proportion in the overall consumption of heavy fuel oil and coal in CHPP-1 recorded during three years (2000-2002) prior to commissioning of replaced boiler No.5;

$\alpha_{PJ,y}$  is the proportion of heavy fuel oil in the overall consumption of heavy fuel oil and coal in CHPP-1 under the project during the year  $y$ .

The minimum annual consumption of coal in CHPP-1 during 2000-2002 was recorded in 2000 and amounted to  $FC_{coal}^{min} = 1\ 290\ 138$  GJ (See Table B.1-1).

The proportion of heavy fuel oil in the overall consumption of heavy fuel oil and coal in CHPP-1 during the year  $y$  prior to the project:

$$\alpha_y = \frac{FC_{fuel\ oil,y}}{FC_{fuel\ oil,y} + FC_{coal,y}}. \quad (B.1-26)$$

The value of  $\alpha_{max}$  is determined as a maximum average annual value of  $\alpha_y$  recorded during three full calendar years from 2000 to 2002:

$$\alpha_{max} = MAX \{ \alpha_{2000}; \alpha_{2001}; \alpha_{2002} \}. \quad (B.1-27)$$

The maximum value of the heavy fuel oil proportion over three years prior to the project was recorded in 2000 and amounted to  $\alpha_{max} = 0.5929$  (See Table B.1-1).

The proportion of heavy fuel oil in the overall consumption of heavy fuel oil and coal in CHPP-1 under the project during the year  $y$ :



$$\alpha_{PJ,y} = \frac{FC_{fuel\ oil,PJ,y}}{FC_{fuel\ oil,PJ,y} + FC_{coal,PJ,y}} \quad (B.1-28)$$

The heavy fuel oil consumption in CHPP-1 under the baseline scenario during the year y, GJ:

$$FC_{fuel\ oil,BL,y} = \frac{HG_{fuel\ oil,BL,y}}{\eta_{fuel\ oil}} \quad (B.1-29)$$

Without the project bark consumption would not have been technically possible, therefore:

$$FC_{bark,BL,y}^v = 0 \quad (B.1-30)$$

The volumetric consumption of sawdust and chip screenings in CHPP-1 under the baseline scenario during the year y, dense m<sup>3</sup>:

$$FC_{sd+spw,BL,y}^v = \frac{HG_{1,sd+spw,BL,y}}{SHG_{sd+spw}^{\max}} \quad (B.1-31)$$

### Project GHG emissions

In accordance with the above mentioned sources, in general case, the project GHG emissions during the year y are calculated by the following formula, tCO<sub>2</sub>e:

$$PE_y = PE_{coal,y} + PE_{fuel\ oil,y} + PE_{BWW\ comb.,y} \quad (B.1-32)$$

where  $PE_{coal,y}$  is the project CO<sub>2</sub> emissions due to coal combustion in CHPP-1 during the year y, tCO<sub>2</sub>e;

$PE_{fuel\ oil,y}$  is the project CO<sub>2</sub> emissions due to heavy fuel oil combustion in CHPP-1 during the year y, tCO<sub>2</sub>e;

$PE_{BWW\ comb.,y}$  is the project N<sub>2</sub>O and CH<sub>4</sub> emissions due to combustion of additional BWW quantity (compared with the project scenario) during the year y, tCO<sub>2</sub>e.

The project CO<sub>2</sub> emissions due to coal combustion in CHPP-1 during the year y are calculated by the following formula, tCO<sub>2</sub>e:

$$PE_{coal,y} = FC_{coal,PJ,y} \times EF_{CO_2,coal} \quad (B.1-33)$$

The project CO<sub>2</sub> emissions due to combustion of heavy fuel oil in CHPP-1 during the year y are calculated by the following formula, tCO<sub>2</sub>e:

$$PE_{fuel\ oil,y} = FC_{fuel\ oil,PJ,y} \times EF_{CO_2,fuel\ oil} \quad (B.1-34)$$

### Emissions of N<sub>2</sub>O and CH<sub>4</sub> from combustion of additional quantity of BWW.

The project implementation resulted in increase in BWW quantity which is combusted in CHPP-1 and therefore in respective increase in N<sub>2</sub>O and CH<sub>4</sub> emissions. CO<sub>2</sub> emissions from biomass combustion are climatically neutral. Preliminary estimations showed that these emissions exceed 2000 tCO<sub>2</sub>e/year, therefore they must be considered as one of the project GHG emission sources.

$$PE_{BWW\ comb.,y} = PE_{bark\ comb.,y} + PE_{sd+spw\ comb.,y} \quad (B.1-35)$$



$$PE_{sd+spw\ comb.,y} = (FC^v_{sd+spw,PJ,y} - FC^v_{sd+spw,BL,y}) \times NCV_{sd+spw}^{av} \times (EF_{CH_4,BWW\ comb.} \times GWP_{CH_4} + EF_{N_2O,BWW\ comb.} \times GWP_{N_2O}) \times 10^{-3} \quad (B.1-36)$$

$$PE_{bark\ comb.,y} = (FC^v_{bark,PJ,y} - FC^v_{bark,BL,y}) \times NCV_{bark}^{av} \times (EF_{CH_4,BWW\ comb.} \times GWP_{CH_4} + EF_{N_2O,BWW\ comb.} \times GWP_{N_2O}) \times 10^{-3} \quad (B.1-37)$$

where  $PE_{sd+spw\ comb.,y}$  is the emissions of N<sub>2</sub>O and CH<sub>4</sub> from combustion of additional quantity of sawdust and chip screenings under the project as compared with the baseline scenario during the year y, tCO<sub>2</sub>e;

$PE_{bark\ comb.,y}$  is the emissions of N<sub>2</sub>O and CH<sub>4</sub> from combustion of additional quantity of bark under the project as compared with the baseline scenario during the year y, tCO<sub>2</sub>e;

$NCV_{sd+spw}^{av}$  is the average net calorific value of sawdust and chip screenings, GJ/dense m<sup>3</sup>;

$NCV_{bark}^{av}$  is the average net calorific value of bark, GJ/dense m<sup>3</sup>;

$GWP_{CH_4}$  is the global warming potential of CH<sub>4</sub>, tCO<sub>2</sub>e/tCH<sub>4</sub>;

$GWP_{N_2O}$  is the global warming potential of N<sub>2</sub>O, tCO<sub>2</sub>e /t N<sub>2</sub>O;

$EF_{CH_4,BWW\ comb.}$  is the CH<sub>4</sub> emission factor for BWW, kg CH<sub>4</sub>/GJ;

$EF_{N_2O,BWW\ comb.}$  is the N<sub>2</sub>O emission factor for BWW, kg N<sub>2</sub>O / GJ;

According to the IPCC Guidelines for National GHG Inventory 2006 [C5], Volume 2, Chapter 2, Table 2.3 for wood biomass the CH<sub>4</sub> emission factor is 0.030 kg CH<sub>4</sub>/GJ and the N<sub>2</sub>O emission factor – 0.004 kg N<sub>2</sub>O/GJ.

Taking into account the relative smallness of the value of CH<sub>4</sub> and N<sub>2</sub>O emissions from BWW combustion, the average net calorific value of sawdust and chip screenings combustion was assumed equal to the average value recorded over three years before the project implementation (2000-2002)  $NCV_{sd+spw}^{av} = 5.724$  GJ/dense m<sup>3</sup>; average net calorific value of bark was assumed equal to the average value recorded over three years before the projection period (2007-2009)  $NCV_{bark}^{av} = 5.612$  GJ/dense m<sup>3</sup>. These values are determined once at the stage of the project documentation development and are assumed to be constant up until 2012.

Without the project implementation bark combustion would have been impossible, therefore  $FC^v_{bark,BL,y} = 0$ .

The final formula for calculation of project GHG emissions:

$$PE_y = PE_{coal,y} + PE_{fuel\ oil,y} + PE_{BWW\ comb.,y} \quad (B.1-38)$$

The project heat production in CHPP-1

For calculation of coal and heavy fuel oil consumption it is necessary to find heat production by CHPP-1 boilers.

Under the project scenario heat is produced by firing sawdust and chip screenings in boiler No.1; bark, sawdust and chip screenings (i.e. all types of BWW) - in retrofitted boiler No.5; coal - in boilers No.2 and No.3; heavy fuel oil - in boiler No.4, as well as in other boilers as a backup fuel.

For the years up to and including 2009, we used data on actual total production of heat in CHPP-1. In projections for the years 2010-2012 the total annual production of heat is assumed equal to the maximum annual value over the last three calendar years (2007-2009), GJ:

$$HG_{CHPP-1,PJ,y} = \text{MAX} \left\{ HG_{CHPP-1,PJ,2007}; HG_{CHPP-1,PJ,2008}; HG_{CHPP-1,PJ,2009} \right\}. \quad (\text{B.1-39})$$

$HG_{CHPP-1,PJ,y} = HG_{CHPP-1,PJ,2007} = 3\,458\,269$  GJ (See Table B.1-3). This value is used only for projections and will have no impact whatsoever upon the actual value of emission reductions based on the monitoring, the same is true for projected parameters of the project scenario specified below.

For the project scenario the total heat production by CHPP-1 boilers can be presented as follows (necessary for the projections for the years 2010-2012):

$$HG_{CHPP-1,PJ,y} = HG_{1,sd+spw,PJ,y} + HG_{5,BWW,PJ,y} + HG_{coal,PJ,y} + HG_{fuel\ oil,PJ,y}, \quad (\text{B.1-40})$$

where  $HG_{1,sd+spw,PJ,y}$  is the heat production by boiler No.1 of CHPP-1 from sawdust and chip screenings under the project during the year  $y$ , GJ;

$HG_{5,BWW,PJ,y}$  is the heat production by boiler No.5 of CHPP-1 from bark, sawdust and chip screenings under the project during the year  $y$ , GJ;

$HG_{coal,PJ,y}$  is the heat production in CHPP-1 from coal under the project during the year  $y$ , GJ;

$HG_{fuel\ oil,PJ,y}$  is the heat production in CHPP-1 from heavy fuel oil under the project during the year  $y$ , GJ.

*Heat production by boiler No.1 from sawdust and chip screenings under the project during the year  $y$  for projections for 2010-2012, GJ;*

$$HG_{1,sd+spw,PJ,y} = \frac{SG_1^{nom} \times T_1^{max} \times (h_s - h_{FW})}{1000} \times (1 - f_1^{min}) \times K_y, \quad (\text{B.1-41})$$

where  $K_y$  is the load factor for boiler No.1 under the project during the year  $y$ .

The projected load factor for boiler No.1 under the project is assumed equal to  $K_y = 0.9$ .

*Heat production by boiler No.5 from bark, sawdust and chip screenings during the year  $y$  in projections for 2010-2012 is assumed as per the design documentation [R10]:*

$$HG_{5,BWW,PJ,y} = 1\,627\,906 \text{ GJ.}$$

*Heat production in CHPP-1 from heavy fuel oil under the project during the year  $y$ , GJ:*

$$HG_{fuel\ oil,PJ,y} = \frac{HG_{CHPP-1,PJ,y} - HG_{1,sd+spw,PJ,y} - HG_{5,BWW,PJ,y}}{1 + \frac{1 - \alpha_{PJ,y}}{\alpha_{PJ,y}} \times \frac{\eta_{coal}}{\eta_{fuel\ oil}}}. \quad (\text{B.1-42})$$

The proportion of heavy fuel oil in the overall consumption of coal and heavy fuel oil in CHPP-1 in projections for 2010-2012 is assumed equal to  $\alpha_{PJ,y} = 0.5$ .

*Heat production in CHPP-1 from coal under the project during the year  $y$  is determined as remainder, GJ:*

$$HG_{coal,PJ,y} = HG_{CHPP-1,PJ,y} - HG_{1,sd+spw,PJ,y} - HG_{5,BWW,PJ,y} - HG_{fuel\ oil,PJ,y}. \quad (\text{B.1-43})$$

Fuel consumption in CHPP-1 under the project

Actual data on fuel consumption in CHPP-1 are known till the year 2009 inclusively (See Table B.1-3).

The projection of fuel consumption for the period 2010-2012 is made as follows.

*Volumetric consumption of bark in CHPP-1 under the project* during the year  $y$  is assumed constant over years and equal to maximum annual value over the last three calendar years (2007-2009), dense  $m^3$ :

$$FC_{bark,PJ,y}^v = \text{MAX} \left\{ FC_{bark,PJ,2008}^v; FC_{bark,PJ,2009}^v; FC_{bark,PJ,2010}^v \right\} \quad (\text{B.1-44})$$

$$FC_{bark,PJ,y}^v = FC_{bark,PJ,2008}^v = 142\,215 \text{ dense } m^3 \text{ (See Table B.1-3).}$$

*Volumetric consumption of sawdust and chip screenings in CHPP-1 under the project* during the year  $y$  is determined as a sum of sawdust and chip screenings fired in boilers No.1 and No.5:

$$FC_{sd+spw,PJ,y}^v = FC_{1,sd+spw,PJ,y}^v + FC_{5,sd+spw,PJ,y}^v, \quad (\text{B.1-45})$$

where  $FC_{1,sd+spw,PJ,y}^v$  is the volumetric consumption of sawdust and chip screenings in boiler No.1 under the project during the year  $y$ , dense  $m^3$ ;

$FC_{5,sd+spw,PJ,y}^v$  is the volumetric consumption of sawdust and chip screenings in boiler No.5 under the project during the year  $y$ , dense  $m^3$ .

The volumetric consumption of sawdust and chip screenings in boiler No.1 under the project during the year  $y$ :

$$FC_{1,sd+spw,PJ,y}^v = \frac{HG_{1,sd+spw,PJ,y}}{SHG_{sd+spw}^{\max}}. \quad (\text{B.1-46})$$

The volumetric consumption of sawdust and chip screenings in boiler No.5 under the project during the year  $y$ :

$$FC_{5,sd+spw,PJ,y}^v = \frac{HG_{5,BWW,PJ,y} - FC_{bark,PJ,y}^v \times NCV_{bark}^{av} \times \eta_{5,PJ}}{\eta_{5,PJ} \times NCV_{sd+spw}^{av}}, \quad (\text{B.1-47})$$

where  $\eta_{5,PJ}$  is the efficiency of boiler No.5 after replacement;

$NCV_{bark}^{av}$  is the net calorific value of bark over the last three calendar years (2007-2009), GJ/dense  $m^3$ .

The efficiency of boiler No.5 after replacement in projections is assumed constant over years and numerically equal according to INEKO's data to  $\eta_{5,PJ} = 0.87$  [R10].

Average net calorific value of bark combustion in 2007-2009 amounted to  $NCV_{bark}^{av} = 5.612$  GJ/dense  $m^3$ .

*Coal consumption in CHPP-1 under the project* during the year  $y$ , GJ:

$$FC_{coal,PJ,y} = \frac{HG_{coal,PJ,y}}{\eta_{coal}}. \quad (\text{B.1-48})$$

*Heavy fuel oil consumption in CHPP-1 under the project* during the year  $y$ , GJ:

$$FC_{fuel\ oil,PJ,y} = \frac{HG_{fuel\ oil,PJ,y}}{\eta_{fuel\ oil}}. \quad (\text{B.1-49})$$



## Leakages

Leakages which take place due to the project include:

- fugitive emissions of CH<sub>4</sub> from production, processing, storage, handling and distribution of fossil fuels used by transport vehicles and energy sources of the Mill;
- transportation of additional quantity of BWW to the Mill for combustion (compared to the baseline scenario), CO<sub>2</sub> emissions from combustion of fossil fuel;
- emissions of CO<sub>2</sub> related to additional energy consumption for fuel preparation as a result of the project.

Fugitive emissions include non-organized fugitive emissions of CH<sub>4</sub> from production, processing, storage, handling and distribution of fossil fuel used by the company's energy sources and motor vehicles operating within the national boundaries. The project implementation leads to reduction in heavy fuel oil and coal consumption at CHPP-1, and therefore to reduction in fugitive emissions. For reasons of conservatism, these leakages were excluded from consideration.

CO<sub>2</sub> emissions due to transportation of additional quantity of BWW to the Mill for combustion (compared to the baseline scenario), CO<sub>2</sub> emissions from combustion of fossil fuel in general case, are to be determined on the basis of fuel consumption by motor vehicles with allowance for the distance from the company to the dump, lifting capacity and specific fuel consumption of the motor vehicle, type of fuel, its CO<sub>2</sub> emission factor and/or other parameters.

For the sake of conservatism and simplification of calculations, emissions due to BWW transportation to dumps under the baseline scenario were excluded from consideration.

### The CO<sub>2</sub> emissions due to transportation of additional quantity of BWW to the Mill for combustion

A considerable proportion of BWW is delivered by motor vehicles from several neighbouring wood working plants of Arkhangelsk. Some of deliveries are made by motor vehicles owned by OJSC "Solombala PPM" and some by motor vehicles owned by other organizations. Besides, fine wood wastes are delivered from the wood preparation shop and from the neighbouring Solombala Saw Mill by conveyors.

The distance to which BWW are transported from the main suppliers (Solombala PPM and Solombala Saw Mill, which are in point of fact located at the same production site) is comparable with the distance to the dump to which these wastes would have been transported in the absence of the project.

The volume of BWW deliveries from other enterprises will not exceed 150 thousand dense m<sup>3</sup> per year. The average delivery distance is not more than 20 km. Thus, one trip corresponds to 40 km travelled. We shall assume that the most typical Russian truck-tractor MAZ with semitrailer will transport not less than 10 dense m<sup>3</sup> (up to 40 bulk m<sup>3</sup>), consuming around 30 liters of diesel fuel per 100 km. Then, the total consumption of diesel fuel per year shall amount to  $150\,000/10 \times 40/100 \times 30 = 180\,000$  l/year. According to WRI 2001d [R19], calorific value and emission factor for diesel fuel may be assumed at 0.0371 GJ/l and 74.01 kgCO<sub>2</sub>/GJ, respectively. Then the annual emissions will total  $180 \times 0.0371 \times 74.01 = 494$  tCO<sub>2</sub>/year.

Taking into account the negligibility of the obtained value (around 0.2 < 1% of annual emission reductions and less than 2000 tCO<sub>2</sub>/year), the CO<sub>2</sub> emissions due to transportation of additional quantity of BWW to the Mill were excluded from consideration.

### Emissions of CO<sub>2</sub> related to additional energy consumption for fuel preparation as a result of the project

The project implementation leads to additional electricity consumption for BWW preparation, however heat consumption for heavy fuel oil heating and electricity consumption for coal pulverization are reduced compared with the baseline scenario.



Solombala PPM does not have separate metering of power consumption at its facility for handling and preparation of BWB. However, it is possible to estimate power consumption proceeding from the installed capacity of the new power equipment, which totals 900 kW [R11].

A very conservative estimation of emissions due to BWB preparation was made proceeding from the assumption that all installed capacity is used during 8000 h per year. The emission factor for grid electricity according to [R3] was assumed equal to 0.5 tCO<sub>2</sub>/MWh, then GHG emissions will be:  $0.9 \times 8000 \times 0.5 = 3600$  tCO<sub>2</sub>/year. It is shown below that these emissions can be excluded from consideration.

According to the data of SPPM's Energy Service for the last years, in order to heat up heavy fuel oil the Mill's heavy fuel oil system consumes not less than 1.5 GJ per tonne of fuel. Savings of heavy fuel oil as a result of the project will amount to around 31 thousand tonnes per year. Then the heat savings will amount to  $1.5 \times 31\,000 = 46\,500$  GJ/year. If we assume that this heat is produced by combustion of heavy fuel oil with 85% efficiency, then the reduction in heavy fuel oil combustion will amount to  $46\,500 / 0.85 = 54\,706$  GJ. The emission factor for heavy fuel oil in accordance with the IPCC Guidelines [R5] is 77.4 kgCO<sub>2</sub>/GJ. Then GHG emissions will be:  $77.4 \times 54.71 = 4\,234$  tCO<sub>2</sub>/year.

Coal is pulverized at CHPP-1 in hammer mills whose specific consumption of power according to [R7] is between 4 and 16 kWh per tonne of coal. Savings of coal as a result of the project will amount to around 26 thousand tonnes per year. Power consumption for coal pulverization, according to the most conservative estimations, will amount to  $4 \times 26\,000 = 104\,000$  kWh/year. If we assume according to [R3] that the estimated value of emission factor for grid electricity is 0.5 tCO<sub>2</sub>/MWh, then then GHG emissions will be:  $104 \times 0.5 = 52$  tCO<sub>2</sub>/year.

Thus the resulting emissions of CO<sub>2</sub> related to additional energy consumption for fuel preparation as a result of the project amount to:  $3600 - 4\,234 - 52 = -686$  tCO<sub>2</sub>/year.

Thus, the project GHG emissions due to power consumption for BWB preparation turn out to be lower than the baseline GHG emissions due to due to heat consumption for heavy fuel oil preparation and power consumption for coal pulverization. Furthermore, the values of estimated minor emissions are not large compared to the main emission reductions achieved under the project. All of this is sufficient for not taking into account minor emissions at the stage of projections nor at the stage of monitoring.

*Since the project implementation leads to reduction in heavy fuel oil and coal consumption at CHPP-1 and the increase in emissions from BWB transport and fuel preparation is small, from conservative point and for the sake of simplicity, the leakages are considered to be equal to zero.*

### **Application of the selected approach**

All necessary parameters for the baseline and project scenarios were determined based on the above specified methodology with allowance for actual CHPP-1 operation data from 2000 to 2009.

Actual data for 2000-2002 were given above in Table B.1-1. Actual and projected data for the period 2003-2012 under the baseline and project scenarios are shown in Tables B.1-2 and B.1-3, respectively. The key parameters for the baseline scenario are described in a tabular form below.



Table B.1-2. Parameters of the baseline scenario

Heat production and fuel consumption in CHPP-1 under the baseline scenario												
Parameter	Designation	Unit	2003	2004	2005	2006	2007	2008	2009	2010	2011	2012
Heat production in CHPP-1, total	$HG_{CHPP-1,BL,y}$	GJ	3 132 554	3 372 901	3 519 885	3 285 891	3 458 269	3 193 270	2 879 057	3 458 269	3 458 269	3 458 269
by boiler No.1 from sawdust and chip screenings	$HG_{1,sd+spw,BL,y}$	GJ	655 298	655 298	655 298	655 298	655 298	655 298	655 298	655 298	655 298	655 298
from heavy fuel oil	$HG_{fuel\ oil,BL,y}$	GJ	1 504 801	1 685 492	1 943 817	1 598 482	1 770 861	1 541 682	1 350 814	1 770 861	1 770 861	1 770 861
from coal	$HG_{coal,BL,y}$	GJ	972 455	1 032 111	920 770	1 032 111	1 032 111	996 290	872 944	1 032 111	1 032 111	1 032 111
Heavy fuel oil consumption in CHPP-1	$FC_{fuel\ oil,BL,y}$	GJ	1 770 354	1 982 932	2 286 844	1 880 567	2 083 365	1 813 744	1 589 193	2 083 365	2 083 365	2 083 365
		t	44 088	49 382	56 951	46 834	51 885	45 169	39 577	51 884	51 884	51 884
Coal consumption in CHPP-1	$FC_{coal,BL,y}$	GJ	1 215 569	1 290 138	1 150 963	1 290 138	1 290 138	1 245 362	1 091 180	1 290 138	1 290 138	1 290 138
		t	71 448	72 679	65 448	73 362	73 362	72 167	64 178	74 763	74 763	74 763
Bark consumption in CHPP-1	$FC^U_{bark,BL,y}$	dense m <sup>3</sup>	0	0	0	0	0	0	0	0	0	0
Sawdust and chip screenings consumption in CHPP-1	$FC^U_{sd+spw,BL,y}$	dense m <sup>3</sup>	145 170	145 170	145 170	145 170	145 170	145 170	145 170	145 170	145 170	145 170
Proportion of heavy fuel oil in overall consumption of heavy fuel oil and coal in CHPP-1	$\alpha_{BL,y}$	GJ/GJ	0.5929	0.6058	0.6652	0.5931	0.6176	0.5929	0.5929	0.6176	0.6176	0.6176
Quantity of bark prevented from dumping as a result of the project	$W_{bark,y}$	t	98 220	115 908	143 806	156 241	151 873	157 148	103 647	157 148	157 148	157 148
Quantity of sawdust and chip screenings prevented from dumping as a result of the project	$W_{sd+spw,y}$	t	78 799	100 193	74 685	84 371	46 187	56 423	49 759	142 335	142 335	142 335

\*Highlighted in grey are actual values



Table B.1-3. Parameters of the project scenario

Heat production and fuel consumption in CHPP-1 under the project												
Parameter	Designation	Unit	2003	2004	2005	2006	2007	2008	2009	2010	2011	2012
Heat production in CHPP-1, total	$HG_{CHPP-1,PJ,y}$	GJ	3 132 554	3 372 901	3 519 885	3 285 891	<b>3 458 269</b>	3 193 270	2 879 057	3 458 269	3 458 269	3 458 269
by boiler No.1 from sawdust and chip screenings	$HG_{1,sd+spw,PJ,y}$	GJ								589 768	589 768	589 768
by boiler No.5 from bark, sawdust and chip screenings	$HG_{5,BWW,PJ,y}$	GJ								1 627 906	1 627 906	1 627 906
from heavy fuel oil	$HG_{fuel\ oil,PJ,y}$	GJ								639 095	639 095	639 095
from coal	$HG_{coal,PJ,y}$	GJ								601 501	601 501	601 501
Heavy fuel oil consumption in CHPP-1	$FC_{fuel\ oil,PJ,y}$	GJ	870 155	524 376	1 137 720	661 175	914 223	541 028	574 313	751 876	751 876	751 876
		t	21 670	13 059	28 333	16 466	22 768	13 474	14 303	18 725	18 725	18 725
Coal consumption in CHPP-1	$FC_{coal,PJ,y}$	GJ	787 706	870 275	572 612	735 587	693 557	832 785	871 123	751 876	751 876	751 876
		t	46 299	49 026	32 561	41 828	39 438	48 259	51 235	43 571	43 571	43 571
Bark consumption in CHPP-1	$FC^v_{bark,PJ,y}$	dense m <sup>3</sup>	88 887	104 894	130 141	141 395	137 442	<b>142 215</b>	93 798	142 215	142 215	142 215
Sawdust and chip screenings consumption in CHPP-1	$FC^v_{sd+spw,PJ,y}$	dense m <sup>3</sup>	240 916	266 911	235 917	247 687	201 290	213 728	205 631	318 117	318 117	318 117
in boiler No.5	$FC^v_{5,sd+spw,PJ,y}$	dense m <sup>3</sup>								187 464	187 464	187 464
in boiler No.1	$FC^v_{1,sd+spw,PJ,y}$	dense m <sup>3</sup>								130 653	130 653	130 653
Proportion of heavy fuel oil in the overall consumption of heavy fuel oil and coal in CHPP-1	$\alpha_{PJ,y}$	GJ/GJ	0.5249	0.3760	0.6652	0.4734	0.5686	0.3938	0.3973	0.500	0.500	0.500

\*Highlighted in grey are actual values



**Data and parameters that are not monitored throughout the crediting period, but are determined only once (and thus remain fixed throughout the crediting period), and that are available already at the stage of determination**

<b>Data/Parameter</b>	$EF_{CO_2,coal}$
Data unit	tCO <sub>2</sub> /GJ
Description	CO <sub>2</sub> emission factor for coal
Time of <u>determination/monitoring</u>	Determined once at the stage of PDD development
Source of data (to be) use	2006 IPCC Guidelines for National Greenhouse Gas Inventories. Volume 2, Chapter 2, Table 2.2. [R5]
Value of data applied (for ex ante calculations/determinations)	0.0946
Justification of the choice of data or description of measurement methods and procedures (to be) applied	Default value
QA/QC procedures (to be) applied	Based on reference data
Any comment	-

<b>Data/Parameter</b>	$EF_{CO_2,fuel\ oil}$
Data unit	tCO <sub>2</sub> /GJ
Description	CO <sub>2</sub> emission factor for heavy fuel oil
Time of <u>determination/monitoring</u>	Determined once at the stage of PDD development
Source of data (to be) use	2006 IPCC Guidelines for National Greenhouse Gas Inventories. Volume 2, Chapter 2, Table 2.2. [R5]
Value of data applied (for ex ante calculations/determinations)	0.0774
Justification of the choice of data or description of measurement methods and procedures (to be) applied	Default value
QA/QC procedures (to be) applied	Based on reference data
Any comment	-

<b>Data/Parameter</b>	$EF_{CH_4,BWW\ comb.}$
Data unit	kg CH <sub>4</sub> /GJ
Description	CH <sub>4</sub> emission factor for BWW
Time of <u>determination/monitoring</u>	Determined once at the stage of PDD development
Source of data (to be) use	2006 IPCC Guidelines for National GHG Inventory. Volume 2, Chapter 2, Table 2.3 [R5]
Value of data applied (for ex ante calculations/determinations)	0.030
Justification of the choice of data or description of measurement methods and	Recommended default value





procedures (to be) applied	
QA/QC procedures (to be) applied	Determined based on reference data
Any comment	-

<b>Data/Parameter</b>	$EF_{N_2O, BWW\ comb.}$
Data unit	kg N <sub>2</sub> O/GJ
Description	N <sub>2</sub> O emission factor for BWW
Time of <u>determination/monitoring</u>	Determined once at the stage of PDD development
Source of data (to be) use	2006 IPCC Guidelines for National GHG Inventory. Volume 2, Chapter 2, Table 2.3 [R5]
Value of data applied (for ex ante calculations/determinations)	0.004
Justification of the choice of data or description of measurement methods and procedures (to be) applied	Recommended default value
QA/QC procedures (to be) applied	Determined based on reference data
Any comment	-

<b>Data/Parameter</b>	$\eta_{coal}$
Data unit	-
Description	Efficiency of coal combustion in CHPP-1 boilers
Time of <u>determination/monitoring</u>	Determined once at the stage of PDD development
Source of data (to be) use	Methodological tool to determine the baseline efficiency of thermal or electric energy generation systems. Version 01. CDM Executive Board. P.7, Table 1. [R6]
Value of data applied (for ex ante calculations/determinations)	0.80
Justification of the choice of data or description of measurement methods and procedures (to be) applied	Value recommended for old coal-fired boilers
QA/QC procedures (to be) applied	Based on reference data
Any comment	-

<b>Data/Parameter</b>	$\eta_{fuel\ oil}$
Data unit	-
Description	Efficiency of heavy fuel oil combustion in CHPP-1 boilers
Time of <u>determination/monitoring</u>	Determined once at the stage of PDD development
Source of data (to be) use	Methodological tool to determine the baseline efficiency of thermal or electric energy generation systems. Version 01. CDM Executive Board. P.7, Table 1. [R6]
Value of data applied	0.85



(for ex ante calculations/determinations)	
Justification of the choice of data or description of measurement methods and procedures (to be) applied	Value recommended for old heavy fuel oil boilers
QA/QC procedures (to be) applied	Based on reference data
Any comment	-

<b>Data/Parameter</b>	$\eta_{sd+spw}$
Data unit	-
Description	Efficiency of sawdust and chip screenings in boiler No.1
Time of <u>determination/monitoring</u>	Determined once at the stage of the PDD development
Source of data (to be) use	Methodological tool to determine the baseline efficiency of thermal or electric energy generation systems. Version 01. CDM Executive Board. P.7, Table 1. [R6]
Value of data applied (for ex ante calculations/determinations)	0.80
Justification of the choice of data or description of measurement methods and procedures (to be) applied	Efficiency of sawdust and chip screenings combustion in boiler No.1 for conservative reasons is assumed constant over years and equal to efficiency of coal combustion in CHPP-1.
QA/QC procedures (to be) applied	Based on reference data
Any comment	-

<b>Data/Parameter</b>	$SHG_{sd+spw}^{\max}$
Data unit	GJ/dense m <sup>3</sup>
Description	Maximum average annual specific production of heat from sawdust and chip screenings in CHPP-1 recorded during three years prior to the commissioning of replaced boiler No.5
Time of <u>determination/monitoring</u>	Determined once at the stage of PDD development
Source of data (to be) use	Calculated based on actual data provided by SPPM
Value of data applied (for ex ante calculations/determinations)	4.514
Justification of the choice of data or description of measurement methods and procedures (to be) applied	Calculations were made using the formulae (B.1-13 - B.1-15). Maximum value of average annual specific production of heat from sawdust and chip screenings in 2000-2002 was recorded in 2000.
QA/QC procedures (to be) applied	Calculated based on actual data
Any comment	-

<b>Data/Parameter</b>	$h_s$
Data unit	kJ/kg
Description	Heat content of fresh steam at standard parameters
Time of	Determined once at the stage of PDD development



<u>determination/monitoring</u>	
Source of data (to be) use	Thermal design of boiler units (Normative method). Publishing House NPO CKTI, St.-Pet., 1998. Table XXV. [R21] GOST 3619-89 “Steam plant boilers. Types and main parameters” (approved by resolution of Gosstandard of USSR, 23 March 1989, No.630). Table 1. [R20]
Value of data applied (for ex ante calculations/determinations)	3309
Justification of the choice of data or description of measurement methods and procedures (to be) applied	Nominal parameters of fresh steam for installed boilers according to [R20]: pressure 3.9 MPa, temperature 440°C. Heat content of steam was determined based on the specified parameters using Table XXV [R21].
QA/QC procedures (to be) applied	Based on reference data
Any comment	-

<b>Data/Parameter</b>	$h_{FW}$
Data unit	kJ/kg
Description	Heat content of feed water at nominal parameters
Time of <u>determination/monitoring</u>	Determined once at the stage of PDD development
Source of data (to be) use	Thermal design of boiler units (Normative method). Publishing House NPO CKTI, St.-Pet., 1998. Table XXV. [R21] GOST 3619-89 “Steam plant boilers. Types and main parameters” (approved by resolution of Gosstandard of USSR, 23 March 1989, No.630). Table 1. [R20]
Value of data applied (for ex ante calculations/determinations)	612
Justification of the choice of data or description of measurement methods and procedures (to be) applied	Nominal parameters of feed water for installed boilers according to [R20]: 145 °C. Heat content of feed water was determined based on the specified parameters using Table XXIV [R21].
QA/QC procedures (to be) applied	Based on reference data
Any comment	-

<b>Data/Parameter</b>	$\rho_{12,bark}$
Data unit	kg/dense m <sup>3</sup>
Description	Density of bark at standard moisture content (i.e. at absolute moisture content of 12%)
Time of <u>determination/monitoring</u>	Determined once at the stage of PDD development
Source of data (to be) use	S.I.Golovkov, I.F. Koperin, V.I.Naidenov. Use of wood wastes in energy production. – M.: Forestry, 1987. p. 18. Table 7 [R4].
Value of data applied (for ex ante calculations/determinations)	680
Justification of the choice of data or description of measurement methods and	Reference data on pine bark density at standard moisture



procedures (to be) applied	
QA/QC procedures (to be) applied	Based on reference data
Any comment	-

<b>Data/Parameter</b>	$\rho_{12, sd+spw}$
Data unit	kg/dense m <sup>3</sup>
Description	Density of sawdust and chip screenings at standard moisture content (i.e. at absolute moisture content of 12%)
Time of <u>determination/monitoring</u>	Determined once at the stage of PDD development
Source of data (to be) use	S.I.Golovkov, I.F. Koperin, V.I.Naidenov. Use of wood wastes in energy production. – M.: Forestry, 1987. p. 17. Table 6 [R4].
Value of data applied (for ex ante calculations/determinations)	500
Justification of the choice of data or description of measurement methods and procedures (to be) applied	Reference data on pine stem wood density at standard moisture
QA/QC procedures (to be) applied	Based on reference data
Any comment	-

<b>Data/Parameter</b>	$M_{bark}$
Data unit	%
Description	Bark moisture content
Time of <u>determination/monitoring</u>	Determined once at the stage of PDD development
Source of data (to be) use	Methane and Nitrous Oxide Emissions from Biomass Waste Stockpiles, PCFplus Research, World Bank, August 2002 [R2]
Value of data applied (for ex ante calculations/determinations)	50
Justification of the choice of data or description of measurement methods and procedures (to be) applied	Recommended default value
QA/QC procedures (to be) applied	Based on reference data
Any comment	-

<b>Data/Parameter</b>	$M_{sd+spw}$
Data unit	%
Description	Moisture content of sawdust and chip screenings
Time of <u>determination/monitoring</u>	Determined once at the stage of the PDD development
Source of data (to be) use	Methane and Nitrous Oxide Emissions from Biomass Waste Stockpiles, PCFplus Research, World Bank, August 2002 [R2]
Value of data applied (for ex ante calculations/determinations)	50



Justification of the choice of data or description of measurement methods and procedures (to be) applied	Recommended default value
QA/QC procedures (to be) applied	Based on reference data
Any comment	-

<b>Data/Parameter</b>	$W_{lignin,BWW}$
Data unit	-
Description	Lignin fraction of C for BWW
Time of <u>determination/monitoring</u>	Determined once at the stage of PDD development
Source of data (to be) use	Methane and Nitrous Oxide Emissions from Biomass Waste Stockpiles, PCFplus Research, World Bank, August 2002 [R2]
Value of data applied (for ex ante calculations/determinations)	0.25
Justification of the choice of data or description of measurement methods and procedures (to be) applied	Recommended default value
QA/QC procedures (to be) applied	Based on reference data
Any comment	-

<b>Data/Parameter</b>	$k_{BWW}$
Data unit	year <sup>-1</sup>
Description	Decomposition rate constant for BWW
Time of <u>determination/monitoring</u>	Determined once at the stage of PDD development
Source of data (to be) use	Methane and Nitrous Oxide Emissions from Biomass Waste Stockpiles, PCFplus Research, World Bank, August 2002 [R2]
Value of data applied (for ex ante calculations/determinations)	0.0462
Justification of the choice of data or description of measurement methods and procedures (to be) applied	Calculated by the formula: $k_{ww} = -\ln(1/2)/15$
QA/QC procedures (to be) applied	Based on reference data
Any comment	15 – recommended default value for the half period of wood, years

<b>Data/Parameter</b>	$C_{BWW}^d$
Data unit	%
Description	Organic carbon content in BWW on dry basis
Time of <u>determination/monitoring</u>	Determined once at the stage of PDD development
Source of data (to be) use	Methane and Nitrous Oxide Emissions from Biomass Waste Stockpiles, PCFplus Research, World Bank, August 2002 [R2]
Value of data applied	53.6



(for ex ante calculations/determinations)	
Justification of the choice of data or description of measurement methods and procedures (to be) applied	Recommended default value
QA/QC procedures (to be) applied	Based on reference data
Any comment	-

<b>Data/Parameter</b>	<i>a</i>
Data unit	m <sup>3</sup> /kg carbon
Description	Conversion factor from kg carbon to landfill gas quantity
Time of <u>determination/monitoring</u>	Determined once at the stage of PDD development
Source of data (to be) use	Methane and Nitrous Oxide Emissions from Biomass Waste Stockpiles, PCFplus Research, World Bank, August 2002 [R2]
Value of data applied (for ex ante calculations/determinations)	1.87
Justification of the choice of data or description of measurement methods and procedures (to be) applied	Calculated by the formula: $a = 22,4/12$
QA/QC procedures (to be) applied	Based on reference data
Any comment	22.4 – is the molar volume of gas at standard conditions, l/mol; 12 – molar mass of C, g/mol.

<b>Data/Parameter</b>	$\zeta$
Data unit	-
Description	Generation factor
Time of <u>determination/monitoring</u>	Determined once at the stage of PDD development
Source of data (to be) use	Methane and Nitrous Oxide Emissions from Biomass Waste Stockpiles, PCFplus Research, World Bank, August 2002 [R2]
Value of data applied (for ex ante calculations/determinations)	0.77
Justification of the choice of data or description of measurement methods and procedures (to be) applied	Recommended default value
QA/QC procedures (to be) applied	Based on reference data
Any comment	-

<b>Data/Parameter</b>	$\varphi$
Data unit	%
Description	Percentage of the stockpile under aerobic conditions
Time of <u>determination/monitoring</u>	Determined once at the stage of PDD development
Source of data (to be) use	Methane and Nitrous Oxide Emissions from Biomass Waste Stockpiles, PCFplus Research, World Bank, August 2002 [R2]



Value of data applied (for ex ante calculations/determinations)	10
Justification of the choice of data or description of measurement methods and procedures (to be) applied	Recommended default value
QA/QC procedures (to be) applied	Based on reference data
Any comment	-

<b>Data/Parameter</b>	$\zeta_{ox}$
Data unit	-
Description	Methane oxidation factor
Time of <u>determination/monitoring</u>	Determined once at the stage of PDD development
Source of data (to be) use	Methane and Nitrous Oxide Emissions from Biomass Waste Stockpiles, PCFplus Research, World Bank, August 2002 [R2]
Value of data applied (for ex ante calculations/determinations)	0.10
Justification of the choice of data or description of measurement methods and procedures (to be) applied	Recommended default value
QA/QC procedures (to be) applied	Based on reference data
Any comment	-

<b>Data/Parameter</b>	$V_m$
Data unit	%
Description	Methane concentration biogas
Time of <u>determination/monitoring</u>	Determined once at the stage of PDD development
Source of data (to be) use	Methane and Nitrous Oxide Emissions from Biomass Waste Stockpiles, PCFplus Research, World Bank, August 2002 [R2]
Value of data applied (for ex ante calculations/determinations)	50
Justification of the choice of data or description of measurement methods and procedures (to be) applied	Recommended default value 60%. A more conservative value (50%) was assumed for calculations.
QA/QC procedures (to be) applied	Based on reference data
Any comment	-

<b>Data/Parameter</b>	$\rho_{CH_4}$
Data unit	kg/m <sup>3</sup>
Description	Methane density
Time of <u>determination/monitoring</u>	Determined once at the stage of PDD development
Source of data (to be) use	Methane and Nitrous Oxide Emissions from Biomass Waste Stockpiles, PCFplus Research, World Bank, August 2002 [R2]



Value of data applied (for ex ante calculations/determinations)	0.716
Justification of the choice of data or description of measurement methods and procedures (to be) applied	Calculated by the formula: $\rho_{CH_4} = 16.04/22.4$
QA/QC procedures (to be) applied	Based on reference data
Any comment	16.04 – molar mass of CH <sub>4</sub> , g/mol; 22.4 – molar volume of gas at standard conditions, l/mol.

<b>Data/Parameter</b>	$GWP_{CH_4}$
Data unit	tCO <sub>2</sub> e/tCH <sub>4</sub>
Description	The Global Warming Potential for CH <sub>4</sub>
Time of <u>determination/monitoring</u>	Determined once at the stage of PDD development
Source of data (to be) use	Methane and Nitrous Oxide Emissions from Biomass Waste Stockpiles, PCFplus Research, World Bank, August 2002 [R2]
Value of data applied (for ex ante calculations/determinations)	21
Justification of the choice of data or description of measurement methods and procedures (to be) applied	Recommended default value
QA/QC procedures (to be) applied	Based on reference data
Any comment	-

<b>Data/Parameter</b>	$GWP_{N_2O}$
Data unit	tCO <sub>2</sub> e /tN <sub>2</sub> O.
Description	The Global Warming Potential for N <sub>2</sub> O
Time of <u>determination/monitoring</u>	Determined once at the stage of PDD development
Source of data (to be) use	Methane and Nitrous Oxide Emissions from Biomass Waste Stockpiles, PCFplus Research, World Bank, August 2002 [R2]
Value of data applied (for ex ante calculations/determinations)	310
Justification of the choice of data or description of measurement methods and procedures (to be) applied	Recommended default value
QA/QC procedures (to be) applied	Based on reference data
Any comment	-

<b>Data/Parameter</b>	$NCV_{sd+spw}^{av}$
Data unit	GJ/dense m <sup>3</sup>
Description	Average net calorific value of sawdust and chip screenings
Time of <u>determination/monitoring</u>	Determined once at the stage of PDD development





Source of data (to be) use	Calculated based on actual data provided by SPPM
Value of data applied (for ex ante calculations/determinations)	5.724
Justification of the choice of data or description of measurement methods and procedures (to be) applied	The average net calorific value of sawdust and chip screenings in 2000-2002, according to the reporting data of the company.
QA/QC procedures (to be) applied	Calculated based on actual data
Any comment	-

<b>Data/Parameter</b>	$NCV_{bark}^{av}$
Data unit	GJ/dense m <sup>3</sup>
Description	Average net calorific value of bark
Time of <u>determination/monitoring</u>	Determined once at the stage of PDD development
Source of data (to be) use	Calculated based on actual data provided by SPPM
Value of data applied (for ex ante calculations/determinations)	5.612
Justification of the choice of data or description of measurement methods and procedures (to be) applied	The average net calorific value of bark in 2007-2009, according to the reporting data of the company.
QA/QC procedures (to be) applied	Calculated based on actual data
Any comment	-

<b>Data/Parameter</b>	$SG_1^{nom}$
Data unit	Tonnes of steam per hour
Description	Nominal steam output of boiler No.1
Time of <u>determination/monitoring</u>	Determined once at the stage of PDD development
Source of data (to be) use	The nameplate data of the boiler
Value of data applied (for ex ante calculations/determinations)	40
Justification of the choice of data or description of measurement methods and procedures (to be) applied	Determined based on the nameplate data of the boiler
QA/QC procedures (to be) applied	Based on reference data
Any comment	-

<b>Data/Parameter</b>	$T_1^{max}$
Data unit	Hours
Description	Maximum annual number of running hours of boiler No.1
Time of <u>determination/monitoring</u>	Determined once at the stage of PDD development
Source of data (to be) use	Actual data provided by SPPM for the period of 2000-2009
Value of data applied	8100



(for ex ante calculations/determinations)	
Justification of the choice of data or description of measurement methods and procedures (to be) applied	Maximum annual number of running hours of the boiler in 2000-2009, according to the reporting data of the company.
QA/QC procedures (to be) applied	Determined based on actual data
Any comment	-

<b>Data/Parameter</b>	$f_1^{\min}$
Data unit	-
Description	Minimum proportion of heavy fuel oil for flame stabilization in boiler No.1
Time of <u>determination/monitoring</u>	Determined once at the stage of PDD development
Source of data (to be) use	Calculated based on actual data provided by SPPM
Value of data applied (for ex ante calculations/determinations)	0.25
Justification of the choice of data or description of measurement methods and procedures (to be) applied	Minimum proportion of heavy fuel oil used for flame stabilization in boiler No.1, according to the reporting data of the company.
QA/QC procedures (to be) applied	Calculated based on actual data
Any comment	Boiler No.1 doesn't have heavy fuel oil flow meters; however, according to operational data even at a minimum injection of heavy fuel oil to the boiler its flow rate amounts to around 1 tonne per hour. The estimations show that in this case around 1/3 of the steam output in boiler No.1 is ensured by combustion of heavy fuel oil. From conservative point of view, the minimum proportion of heavy fuel oil for flame stabilization was assumed equal to $f_1^{\min} = 0.25$ .

<b>Data/Parameter</b>	$FC_{fuel\ oil, y}$						
Data unit	GJ						
Description	Consumption of heavy fuel oil in CHPP-1 during the year $y$ in 2000-2002						
Time of <u>determination/monitoring</u>	Determined once at the stage of PDD development						
Source of data (to be) use	Determined based on actual data provided by SPPM						
Value of data applied (for ex ante calculations/determinations)	<table border="1"> <tr> <td>2000</td> <td>1 879 123</td> </tr> <tr> <td>2001</td> <td>1 616 476</td> </tr> <tr> <td>2002</td> <td>2 010 813</td> </tr> </table>	2000	1 879 123	2001	1 616 476	2002	2 010 813
2000	1 879 123						
2001	1 616 476						
2002	2 010 813						
Justification of the choice of data or description of measurement methods and procedures (to be) applied	Consumption of heavy fuel oil in CHPP-1 during the year $y$ in 2000-2002, according to the reporting data of the company.						
QA/QC procedures (to be) applied	Determined based on actual data						
Any comment	-						



<b>Data/Parameter</b>	$FC_{coal,y}$	
Data unit	GJ	
Description	Coal consumption in CHPP-1 during the year $y$ in 2000-2002	
Time of <u>determination/monitoring</u>	Determined once at the stage of PDD development	
Source of data (to be) use	Determined based on actual data provided by SPPM	
Value of data applied (for ex ante calculations/determinations)	2000	1 290 138
	2001	1 424 378
	2002	1 411 071
Justification of the choice of data or description of measurement methods and procedures (to be) applied	Coal consumption in CHPP-1 during the year $y$ in 2000-2002, according to the reporting data of the company.	
QA/QC procedures (to be) applied	Determined based on actual data	
Any comment	-	

<b>Data/Parameter</b>	$HG_{CHPP-1,y}$	
Data unit	GJ	
Description	Total heat production by CHPP-1 boilers in 2000-2002	
Time of <u>determination/monitoring</u>	Determined once at the stage of PDD development	
Source of data (to be) use	Calculated based on actual data provided by SPPM	
Value of data applied (for ex ante calculations/determinations)	2000	3 075 770
	2001	2 932 227
	2002	3 353 887
Justification of the choice of data or description of measurement methods and procedures (to be) applied	Total heat production by CHPP-1 boilers in 2000-2002, according to the reporting data of the company.	
QA/QC procedures (to be) applied	Determined based on actual data	
Any comment	-	

### **Data and parameters that are monitored throughout the crediting period**

<b>Data/Parameter</b>	$FC_{coal,PJ,y}^m$	
Data unit	t	
Description	Mass consumption of coal in CHPP-1 during the year $y$	
Time of <u>determination/monitoring</u>	Once a year	
Source of data (to be) use	Department of Chief Power Engineer of SPPM (actual data for the mass consumption of coal in CHPP-1 during the year $y$ )	
Value of data applied (for ex ante calculations/determinations)	2008	48 259
	2009	51 235
	2010	43 571
	2011	43 571
	2012	43 571
Justification of the choice of data or description of	For the years up to and including 2009, used data on actual mass consumption of coal in CHPP-1, according to the reporting data of	



measurement methods and procedures (to be) applied	<p>the company. In projections for the years 2010-2012 formula evaluations were used:</p> $FC_{coal,PJ,y} = \frac{HG_{coal,PJ,y}}{\eta_{coal}};$ $FC_{coal,PJ,y}^m = \frac{FC_{coal,PJ,y}}{NCV_{coal,y}};$ <p><math>HG_{coal,PJ,y}</math> is heat production in CHPP-1 from coal under the project during the year y, GJ;</p> <p><math>FC_{coal,PJ,y}</math> is the project coal consumption in CHPP-1 during the year y, GJ;</p> <p><math>NCV_{coal,y}</math> is the average net calorific value of coal under the project during the year y, GJ/t.</p>
QA/QC procedures (to be) applied	<p>The mass consumption of coal is measured with the help of weighs installed at the belt conveyor which supplies coal for combustion to CHPP-1 boilers.</p> <p>The weighs are regularly calibrated in accordance with the schedule and procedure for checking of instrumentation and control equipment adopted at the Mill. Moreover, for the sake of cross-check, coal consumption is also estimated using a reverse balance method based on heat output by coal-fired boilers and is compared with the coal suppliers' data.</p>
Any comment	-

<b>Data/Parameter</b>	$FC_{fuel\ oil,PJ,y}^m$											
Data unit	t											
Description	Mass consumption of heavy fuel oil in CHPP-1 during the year y											
Time of determination/monitoring	Once a year											
Source of data (to be) use	Department of Chief Power Engineer of SPPM (actual data for the mass consumption of heavy fuel oil in CHPP-1 during the year y)											
Value of data applied (for ex ante calculations/determinations)	<table border="1"> <tr><td>2008</td><td>13 474</td></tr> <tr><td>2009</td><td>14 303</td></tr> <tr><td>2010</td><td>18 725</td></tr> <tr><td>2011</td><td>18 725</td></tr> <tr><td>2012</td><td>18 725</td></tr> </table>	2008	13 474	2009	14 303	2010	18 725	2011	18 725	2012	18 725	
2008	13 474											
2009	14 303											
2010	18 725											
2011	18 725											
2012	18 725											
Justification of the choice of data or description of measurement methods and procedures (to be) applied	<p>For the years up to and including 2009, used data on actual mass consumption of heavy fuel oil in CHPP-1, according to the reporting data of the company. In projections for the years 2010-2012 formula evaluations were used:</p> $FC_{fuel\ oil,PJ,y} = \frac{HG_{fuel\ oil,PJ,y}}{\eta_{fuel\ oil}};$ $FC_{fuel\ oil,PJ,y}^m = \frac{FC_{coal,PJ,y}}{NCV_{fuel\ oil,y}};$											



	<p><math>HG_{fuel\ oil,PJ,y}</math> is heat production in CHPP-1 from heavy fuel oil under the project during the year <math>y</math>, GJ;</p> <p><math>FC_{fuel\ oil,PJ,y}</math> is the project consumption of heavy fuel oil in CHPP-1 during the year <math>y</math>, GJ.</p> <p><math>NCV_{fuel\ oil,y}</math> is the average net calorific value of heavy fuel oil under the project during the year <math>y</math>, GJ/t.</p>
QA/QC procedures (to be) applied	<p>The mass consumption of heavy fuel oil is measured by flow meters.</p> <p>The flow meters are regularly checked in accordance with the schedule and procedure for checking of instrumentation and control equipment adopted at the Mill.</p> <p>For the sake of cross-check, the consumption of heavy fuel oil is also estimated using a reverse balance method based on heat output by boilers.</p>
Any comment	-

<b>Data/Parameter</b>	$NCV_{coal,y}$										
Data unit	GJ/t										
Description	Average net calorific value of coal during the year $y$										
Time of <u>determination/monitoring</u>	Once a year										
Source of data (to be) use	Department of Chief Power Engineer of SPPM (actual data for the average net calorific value of coal during the year $y$ )										
Value of data applied (for ex ante calculations/determinations)	<table border="1"> <tr> <td>2008</td> <td>17.26</td> </tr> <tr> <td>2009</td> <td>17.00</td> </tr> <tr> <td>2010</td> <td>17.26</td> </tr> <tr> <td>2011</td> <td>17.26</td> </tr> <tr> <td>2012</td> <td>17.26</td> </tr> </table>	2008	17.26	2009	17.00	2010	17.26	2011	17.26	2012	17.26
2008	17.26										
2009	17.00										
2010	17.26										
2011	17.26										
2012	17.26										
Justification of the choice of data or description of measurement methods and procedures (to be) applied	<p>For the years up to and including 2009, used data on actual average net calorific value of coal, according to the reporting data of the company. In projections for the years 2010-2012 it is assumed constant over years and equal to weighted average annual value over the last three calendar years (2007-2009).</p> <p>This value is used only for projections and will have no impact whatsoever upon the actual value of emission reductions based on the monitoring.</p>										
QA/QC procedures (to be) applied	Data provided by the certified laboratories of the suppliers are used. At the year end an average value is determined.										
Any comment	-										

<b>Data/Parameter</b>	$NCV_{fuel\ oil,y}$
Data unit	GJ/t
Description	Average net calorific value of heavy fuel oil during the year $y$
Time of <u>determination/monitoring</u>	Once a year
Source of data (to be) use	Department of Chief Power Engineer of SPPM (actual data for the average net calorific value of heavy fuel oil during the year $y$ )



Value of data applied (for ex ante calculations/determinations)	2008	40.15
	2009	40.15
	2010	40.15
	2011	40.15
	2012	40.15
Justification of the choice of data or description of measurement methods and procedures (to be) applied	<p>For the years up to and including 2009, used data on actual average net calorific value of heavy fuel oil, according to the reporting data of the company. In projections for the years 2010-2012 it is assumed constant over years and equal to weighted average annual value over the last three calendar years (2007-2009).</p> <p>This value is used only for projections and will have no impact whatsoever upon the actual value of emission reductions based on the monitoring.</p>	
QA/QC procedures (to be) applied	Data provided by the certified laboratories of the suppliers are used. At the year end an average value is determined.	
Any comment	-	

<b>Data/Parameter</b>	$FC_{sd+spw,PJ,y}^v$			
Data unit	dense m <sup>3</sup>			
Description	Volumetric consumption of sawdust and chip screenings in CHPP-1			
Time of determination/monitoring	Once a year			
Source of data (to be) use	Department of Chief Power Engineer of SPPM (actual data for the volumetric consumption of sawdust and chip screenings in CHPP-1 during the year <i>y</i> )			
Value of data applied (for ex ante calculations/determinations)	2003	240 916	2008	213 728
	2004	266 911	2009	205 631
	2005	235 917	2010	318 117
	2006	247 687	2011	318 117
	2007	201 290	2012	318 117
Justification of the choice of data or description of measurement methods and procedures (to be) applied	<p>For the years up to and including 2009, used data on actual volumetric consumption of sawdust and chip screenings (separate data are available and will be monitored) in CHPP-1, according to the reporting data of the company.</p> <p>In projections of GHG emission reduction for the years 2010-2012 volumetric consumption of sawdust and chip screenings in CHPP-1 was evaluated by formulas B.1-45 – B.1-47.</p>			
QA/QC procedures (to be) applied	<p>At the end of each month the Chief Power Engineer forms a committee consisting of representatives of CHPP-1, the Repairs Department and “Solombalales” Management Company in order to determine the remaining amount of sawdust and chip screenings at the bark and sawdust storages near chip buffers, of sawdust at the timber yard.</p> <p>Based on the results of the inspection the Committee draws up a Protocol. Based on the Protocol and Feed Stock Supply Reports, the weight-point man of CHPP-1 executes bark and wood waste fuel flow certificates, in which consumption sawdust is estimated based on the remaining quantities as of the beginning and end of month, as well as based on feedstock supply in the previous month.</p>			
Any comment	-			



<b>Data/Parameter</b>	$FC^v_{bark,PJ,y}$			
Data unit	dense m <sup>3</sup>			
Description	Volumetric consumption of bark in CHPP-1 during the year <i>y</i>			
Time of <u>determination/monitoring</u>	Once a year			
Source of data (to be) use	Department of Chief Power Engineer of SPPM (actual data for the volumetric consumption of bark in CHPP- during the year <i>y</i> )			
Value of data applied (for ex ante calculations/determinations)	2003	88 887	2008	142 215
	2004	104 894	2009	93 798
	2005	130 141	2010	142 215
	2006	141 395	2011	142 215
	2007	137 442	2012	142 215
Justification of the choice of data or description of measurement methods and procedures (to be) applied	<p>For the years up to and including 2009, used data on actual volumetric consumption of bark in CHPP-1, according to the reporting data of the company. In projections for the years 2010-2012 it is assumed constant over years and equal to maximum annual value over the last three calendar years (2007-2009).</p> <p><math>FC^v_{bark,PJ,y} = FC^v_{bark,PJ,2008} = 142\,215</math> dense m<sup>3</sup>. This value is used only for projections and will have no impact whatsoever upon the actual value of emission reductions based on the monitoring.</p>			
QA/QC procedures (to be) applied	<p>At the end of each month the Chief Power Engineer forms a committee consisting of representatives of CHPP-1, the Repairs Department and “Solombalales” Management Company in order to determine the remaining amount of bark at the bark and sawdust storages near chip buffers, of sawdust at the timber yard.</p> <p>Based on the results of the inspection the Committee draws up a Protocol. Based on the Protocol and Feed Stock Supply Reports, the weight-point man of CHPP-1 executes bark and wood waste fuel flow certificates, in which consumption sawdust is estimated based on the remaining quantities as of the beginning and end of month, as well as based on feedstock supply in the previous month.</p>			
Any comment	-			

<b>Data/Parameter</b>	$HG_{CHPP-1,PJ,y}$	
Data unit	GJ	
Description	Total heat production by boilers of CHPP-1 during the year <i>y</i>	
Time of <u>determination/monitoring</u>	Once a year	
Source of data (to be) use	Department of Chief Power Engineer of SPPM (actual data for the total heat production by boilers of CHPP-1 during the year <i>y</i> )	
Value of data applied (for ex ante calculations/determinations)	2008	3 193 270
	2009	2 879 057
	2010	3 458 269
	2011	3 458 269
	2012	3 458 269
Justification of the choice of data or description of	For the years up to and including 2009, used data on actual total production of heat in CHPP-1, according to the reporting data of the	



measurement methods and procedures (to be) applied	company. In projections for the years 2010-2012 it is assumed equal to the maximum annual value over the last three calendar years (2007-2009). $HG_{CHPP-1,PJ,y} = HG_{CHPP-1,PJ,2007} = 3\,458\,269$ GJ. This value is used only for projections and will have no impact whatsoever upon the actual value of emission reductions based on the monitoring.
QA/QC procedures (to be) applied	In order to monitor heat output by CHPP-1 boilers the steam flow meters, temperature and pressure gauges are used. Measuring devices are regularly checked in accordance with the schedule and procedure for checking of instrumentation and control equipment adopted at the Mill. All current signals from the measuring devices are sent to the automated management system Damatic, where heat output is automatically calculated.
Any comment	-

## **B.2. Description of how the anthropogenic emissions of greenhouse gases by sources are reduced below those that would have occurred in the absence of the JI project:**

The approach described in paragraph 2 (a) of Annex 1 to the “Guidelines on criteria for baseline setting and monitoring” [R1] was chosen to demonstrate that reduction in greenhouse gas emissions from sources achieved by the project is additional to that which might have otherwise occurred.

Within the framework of the chosen approach, the project additionality was analyzed using the analysis of the project alternatives, investment analysis and common practice analysis.

### **Analysis of the project alternatives**

The groups of alternative options for the following two types of project activity were considered separately:

- Handling of surplus BWW (the volume of which is equal to the increase in BWW combustion in CHPP-1 as a result of the project);
- Production of the lacking quantity of heat (steam) for the Mill (which is equal to the quantity of steam produced in CHPP-1 due to increase in the volume and efficiency of BWW combustion as a result of the project).

The following alternatives of surplus BWW handling were identified:

- Alternative W1. Continuation of the current situation;
- Alternative W2. Use of BWW as fuel for heat and power generation at Arkhangelsk CHPP;
- Alternative W3. Use of BWW as feedstock for the Hydrolysis Plant;
- Alternative W4. Project activity without joint implementation mechanism.

The following alternatives covering generation of the required amount of heat (steam) for the Mill were identified:

- Alternative H1. Continuation of the current situation;
- Alternative H2. Reduction in coal and residual fuel oil consumption by CHPP-1 and purchase of the lacking amount of heat from external suppliers;
- Alternative H3. Installation of a new coal-fired boiler in CHPP-1;





- Alternative H4. Switching CHPP-1 to natural gas;  
Alternative H5. Project activity without joint implementation mechanism.

The detailed analysis of the project alternative is given in Section B.1. The analysis of the project alternatives indicated that the project activity without joint implementation mechanism can hardly be considered as the baseline scenario. The combination of alternatives W1 and H1, both of which envisage continuation of the current situation, is viewed as the most likely baseline scenario.

### **The investment analysis**

Main economic parameters of the project were compared for the two project implementation options:

- (a) without sale of GHG emission reductions;
- (b) with sale of GHG emission reductions.

The investment analysis was undertaken using data and assumptions relevant for the situation in 2000 before the project starting date.

The dollar exchange rate was assumed at 28 RUR/USD.

The total amount of capital investments in the project was estimated at USD 4.596 million.

The expected price of emission reduction unit (ERU) generated in 2008-2012 was assumed equal to 10 USD/tCO<sub>2e</sub>, the expected price of early emission reductions (2003-2007) – 3 USD/tCO<sub>2e</sub>.

The time horizon of the analysis is limited to 2020.

The discount rate was determined with the help of the methodology recommended in the resolution of the Russian Government No. 1470 of 22 November 1997 “On approval of the procedure for tender-based provision of state guarantees out of the funds of the Russian Federation development budget and on approval of the statute on investment project efficiency assessment to be applied when the centralized investment resources of the Russian Federation development budget are allocated on a tender basis”<sup>7</sup>.

According to this methodology the discount rate is calculated as follows:

$$r = R_F + R_P, \quad (\text{B.2-1})$$

where  $r$  is the estimated discount rate, %;

$R_F$  is the discount rate without allowance for project risk, %;

$R_P$  is the allowance for risk.

$$R_F = \frac{R_{CB} - i}{100 + i} \times 100, \quad (\text{B.2-2})$$

where  $R_{CB}$  is the refinance rate of the Central Bank of the Russian Federation,  $R_{CB} = 25\%$ <sup>8</sup>.

$i$  is the expected rate of inflation, %.  $i = 12\%$ <sup>9</sup>.

The project risks, taking into account introduction of a BWW utilization technology which was new for the company, should be considered no less than medium. In this case the corresponding allowance for risk should be taken from the recommended range of 8-10%. It was assumed that  $R_P = 9\%$ .

<sup>7</sup> <http://www.mnogo zakonov.ru/catalog/date/1997/11/22/10919/textpage/4/>

<sup>8</sup> [http://www.cbr.ru/print.asp?file=/statistics/credit\\_statistics/refinancing\\_rates.htm](http://www.cbr.ru/print.asp?file=/statistics/credit_statistics/refinancing_rates.htm)

<sup>9</sup> [http://www.budgetrf.ru/Publications/2001/Adoption/Federal/Npd/Budgetlaws/Budget/150FZ27122000/150FZ27122000\\_short00.htm](http://www.budgetrf.ru/Publications/2001/Adoption/Federal/Npd/Budgetlaws/Budget/150FZ27122000/150FZ27122000_short00.htm)

$$\text{Then } r = R_f + R_p = \frac{25 - 12}{100 + 12} \times 100 + 9 = 20.6\%$$

The discount rate was finally assumed equal to 20%.

The results of calculation of the net present value (NPV) and the internal rate of return (IRR) for the two project implementation options are given in Table B.2-1, detailed calculations are given in Annex 2-3.

As is seen, the project implementation without sale of ERUs has a negative NPV and IRR is lower than 20%, whereas additional revenues from sale of emission reductions significantly increase the project economic appeal: NPV = USD 644 thousand, IRR = 22.73 > 20%.

**Table B.2-1. Comparison of NPV and IRR**

Parameter	Unit	Project without sale of ERUs	Project with sale of ERUs
NPV	Thousand USD	-1 073	644
IRR	%	15.07	22.73

The analysis of the project sensitivity to the change of main parameters is given further below (See Table B.2-2). Due to the revenues received from sale of emission reductions the project becomes much less sensitive to risks demonstrating in all considered cases an IRR higher than 20%, whereas without sale of emission reductions in all of the cases IRR is lower than 20%.

**Table B.2-2. The sensitivity analysis**

Parameter	Unit	Project without sale of ERUs	Project with sale of ERUs
1) Increase in investments by 10%			
NPV	Thousand USD	-1 517	200
IRR	%	13.58	20.79
2) Reduction in investments by 10%			
NPV	Thousand USD	-630	1 087
IRR	%	16.83	25.02
3) Increase in the total savings of heavy fuel oil and coal by 10%			
NPV	Thousand USD	-645	1 244
IRR	%	17.08	25.17
4) Reduction in the total savings of heavy fuel oil and coal by 10%			
NPV	Thousand USD	-1 502	44
IRR	%	12.97	20.19
5) Increase in the proportion of heavy fuel oil in the overall consumption of heavy fuel oil and coal by 10%			
NPV	Thousand USD	-893	799
IRR	%	15.93	23.37
6) Reduction in the proportion of heavy fuel oil in the overall consumption of heavy fuel oil and coal by 10%			
NPV	Thousand USD	-1 254	489
IRR	%	14.20	22.08
7) Increase in the price of GHG emission reduction by 10%			
NPV	Thousand USD	-1 073	815
IRR	%	15.07	23.43



8) Reduction in the price of GHG emission reduction by 10%			
NPV	Thousand USD	-1 073	472
IRR	%	15.07	22.02%

### **Common practice analysis**

For pulp and paper mills in Russia the common practice is production of heat and electricity by energy sources (CHPPs and boiler houses) with a high proportion of fossil fuel consumption (coal, heavy fuel oil, natural gas). The enterprises where pulp is cooked also use black liquor as fuel. As for wood wastes, mainly the less moist sawdust, chip screenings, off-grade chips and timber residues are used as fuel.

Significant quantities of highly moist bark are still being dumped due to the difficulties associated with its combustion and high consumption of fossil fuel for flame stabilization. Disposal of bark and other wood wastes at dumps is permitted by the environmental legislation of Russia.

As of the date of the project commencement (December 2000) many Russian pulp and paper mills were equipped with low-efficiency utilizing boilers designed for bed firing of moist wood wastes only together with significant quantities of heavy fuel oil or natural gas for flame stabilization.

By the time the project was started at Solombala PPM the technology of fluidized bed combustion had been scarcely applied in Russia. Since 2000 there has not been any project of this type in Russia implemented without the joint implementation mechanism and that are published in open sources or known to the project developers, which means that this project is not common practice.

**Proceeding from the above, the emission reductions achieved due to the project are additional to those that might have otherwise occurred.**

### **B.3. Description of how the definition of the project boundary is applied to the project:**

Fig.3-1 and B.3-2 show the boundaries, components, main energy, fuel and waste flows of the baseline and project respectively. Table B.3-1 shows emission sources included in and excluded from the project boundaries.

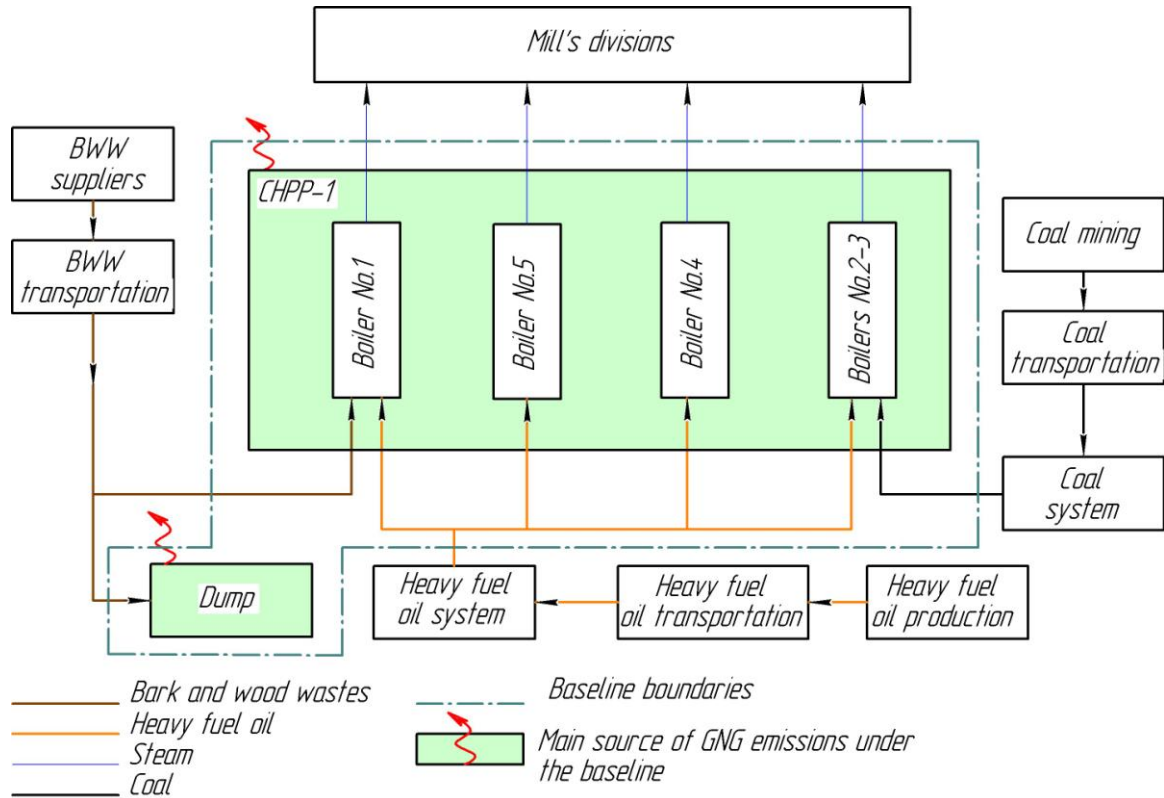

Fig. B.3-1. Boundaries, main components and flows for the baseline scenario

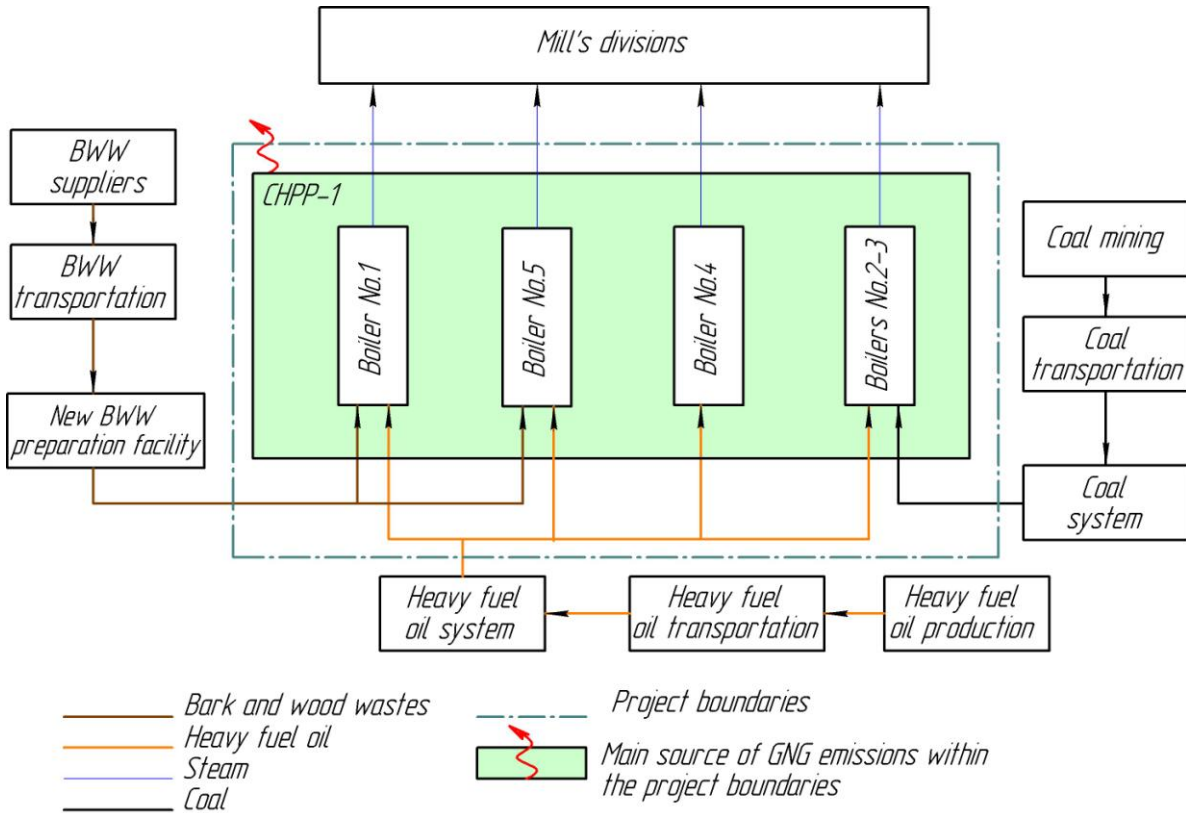

Fig. B.3-2. Boundaries, main components and flows for the project scenario

**Table B.3-1. Emission sources included in and excluded from the project boundaries**

	Sources	Gas	Incl./Excl.	Justification / Explanation
<b>Baseline</b>	CHPP-1, Combustion of heavy fuel oil	CO <sub>2</sub>	<b>Incl.</b>	<b>Main emission source</b>
		CH <sub>4</sub>	Excl.	Negligible. Conservative
		N <sub>2</sub> O	Excl.	Negligible. Conservative
	CHPP-1, Coal combustion	CO <sub>2</sub>	<b>Incl.</b>	<b>Main emission source</b>
		CH <sub>4</sub>	Excl.	Negligible. Conservative
		N <sub>2</sub> O	Excl.	Negligible. Conservative
	BWW dumps, prevented (due to the project) emissions from anaerobic decomposition of BWW	CO <sub>2</sub>	Excl.	Climatically neutral
		CH <sub>4</sub>	<b>Incl.</b>	<b>Main emission source</b>
		N <sub>2</sub> O	Excl.	Negligible. Conservative
<b>Project</b>	CHPP-1, Combustion of heavy fuel oil	CO <sub>2</sub>	<b>Incl.</b>	<b>Main emission source</b>
		CH <sub>4</sub>	Excl.	Negligible
		N <sub>2</sub> O	Excl.	Negligible
	CHPP-1, Combustion of coal	CO <sub>2</sub>	<b>Incl.</b>	<b>Main emission source</b>
		CH <sub>4</sub>	Excl.	Negligible
		N <sub>2</sub> O	Excl.	Negligible
	CHPP-1, Combustion of additional amount of BWW (compared with the baseline scenario)	CO <sub>2</sub>	Excl.	Negligible
		CH <sub>4</sub>	<b>Incl.</b>	<b>Main emission source</b>
		N <sub>2</sub> O	<b>Incl.</b>	<b>Main emission source</b>
<b>Leakages</b>	Production, processing, storage, delivery and distribution of fossil fuel, fugitive emissions	CO <sub>2</sub>	Excl.	Negligible. Conservative
		CH <sub>4</sub>	Excl.	Excluded from consideration because due to the project consumption of fossil fuel reduces. Conservative
		N <sub>2</sub> O	Excl.	Negligible. Conservative
	Transportation of additional amount of BWW to the Mill (for combustion)	CO <sub>2</sub>	Excl.*	Modest and are offset by other minor emissions
		CH <sub>4</sub>	Excl.	Negligible
		N <sub>2</sub> O	Excl.	Negligible
	Fuel preparation facilities, Additional energy consumption (compared with the baseline scenario) for fuel preparation	CO <sub>2</sub>	Excl.*	Modest and are offset by other minor emissions
		CH <sub>4</sub>	Excl.	Negligible
		N <sub>2</sub> O	Excl.	Negligible

\* Numerical evaluation was made for these emissions (See Section B.1).

<b>B.4. Further <u>baseline</u> information, including the date of <u>baseline</u> setting and the name(s) of the person(s)/entity(ies) setting the <u>baseline</u>:</b>
--

The date of baseline setting: 01/11/2010

The baseline was developed by CCGS LLC (CCGS LLC is not the project participant listed in Annex 1 to the PDD)

The contact person: Dmitry Potashev

E-mail: d.potashev@ccgs.ru



**SECTION C. Duration of the project / crediting period**

**C.1. Starting date of the project:**

December 10, 2000 (signing of the contract for replacement of boiler No.5 with CJSC “AMU Sevzapenergomontazh”)

**C.2. Expected operational lifetime of the project:**

20 years / 240 months (the expected lifetime of main equipment)

**C.3. Length of the crediting period:**

5 years / 60 months (from January 1, 2008 to December 31, 2012)

**SECTION D. Monitoring plan****D.1. Description of monitoring plan chosen:**

For development of the project monitoring plan the PDD-writer used a JI-specific approach in accordance with paragraph 9 (a) of the “Guidance on criteria for baseline setting and monitoring” [R1].

The data required for estimation of GHG emission reductions are to be collected at the Mill in any case.

**D.1.1. Option 1 – Monitoring of the emissions in the project scenario and the baseline scenario:****D.1.1.1. Data to be collected in order to monitor emissions from the project, and how these data will be archived:**

ID number (Please use numbers to ease cross-referencing to D.2.)	Data variable	Source of data	Data unit	Measured (m), calculated (c), estimated (e)	Recording frequency	Proportion of data to be monitored	How will the data be archived? (electronic/ paper)	Comment
1. $FC_{coal,PJ,y}^m$	Mass consumption of coal in CHPP-1	Department of Chief Power Engineer	t	m	Continuously	100%	Electronic and paper	Weight and balance methods and the suppliers' data are used
2. $FC_{fuel\ oil,PJ,y}^m$	Mass consumption of heavy fuel oil in CHPP-1	Department of Chief Power Engineer	t	m	Continuously	100%	Electronic and paper	Readings of flow meters, balance method
3. $NCV_{coal,y}$	Average net calorific value of coal	Department of Chief Power Engineer	GJ/t	m	Each batch of fuel	100%	Electronic and paper	Fuel suppliers' certificates
4. $NCV_{fuel\ oil,y}$	Average net calorific value of heavy fuel oil	Department of Chief Power Engineer	GJ/t	m	Each batch of fuel	100%	Electronic and paper	Fuel suppliers' certificates
5. $FC_{sd,PJ,y}^v$	Volumetric consumption of sawdust in CHPP-1	Department of Chief Power Engineer	dense m <sup>3</sup>	e	Monthly	100%	Electronic and paper	Results of inventory of the quantities remaining in



								stock
6. $FC_{spw,PJ,y}^v$	Volumetric consumption of chip screenings in CHPP-1	Department of Chief Power Engineer	dense m <sup>3</sup>	e	Monthly	100%	Electronic and paper	Results of inventory of the quantities remaining in stock
7. $FC_{bark,PJ,y}^v$	Volumetric consumption of bark in CHPP-1	Department of Chief Power Engineer	dense m <sup>3</sup>	e	Monthly	100%	Electronic and paper	Results of inventory of the quantities remaining in stock

#### D.1.1.2. Description of formulae used to estimate project emissions (for each gas, source etc.; emissions in units of CO<sub>2</sub> equivalent):

The project GHG emissions are due to combustion of fossil fuel (coal and heavy fuel oil) in CHPP-1 for heat production during the year y, tCO<sub>2</sub>e:

$$PE_y = PE_{coal,y} + PE_{fuel\ oil,y} + PE_{BWW\ comb.,y}, \quad (D.1-1)$$

where  $PE_{coal,y}$  is the project emissions of CO<sub>2</sub> due to coal combustion in CHPP-1 during the year y, tCO<sub>2</sub>e;

$PE_{fuel\ oil,y}$  is the project emissions of CO<sub>2</sub> due to heavy fuel oil combustion in CHPP-1 during the year y, tCO<sub>2</sub>e;

$PE_{BWW\ comb.,y}$  is the project N<sub>2</sub>O and CH<sub>4</sub> emissions due to combustion of additional amount of BWW (as compared with the baseline scenario) during the year y, tCO<sub>2</sub>e.

$$PE_{coal,y} = FC_{coal,PJ,y} \times EF_{CO_2,coal}, \quad (D.1-2)$$

where  $EF_{CO_2,coal}$  is the CO<sub>2</sub> emission factor for coal, tCO<sub>2</sub>/GJ. In accordance with IPCC Guidelines [R5]  $EF_{CO_2,coal} = 0.0946$  tCO<sub>2</sub>/GJ;

$FC_{coal,PJ,y}$  is the project coal consumption in CHPP-1 during the year y, GJ.

$$FC_{coal,PJ,y} = FC_{coal,PJ,y}^m \times NCV_{coal,y}, \quad (D.1-3)$$

where  $FC_{coal,PJ,y}^m$  is the project mass consumption of coal in CHPP-1 during the year y (this value is to be monitored), t;





$NCV_{coal,y}$  is the average net calorific value of coal under the project during the year  $y$  (this value is to be monitored), GJ/t.

$$PE_{fuel\ oil,y} = FC_{fuel\ oil,PJ,y} \times EF_{CO_2,fuel\ oil}, \quad (D.1-4)$$

where  $EF_{CO_2,fuel\ oil}$  is the CO<sub>2</sub> emission factor for heavy fuel oil, tCO<sub>2</sub>/GJ. In accordance with IPCC Guidelines [R5]  $EF_{CO_2,fuel\ oil} = 0.0774$  tCO<sub>2</sub>/GJ;

$FC_{fuel\ oil,PJ,y}$  is the project consumption of heavy fuel oil in CHPP-1 during the year  $y$ , GJ.

$$FC_{fuel\ oil,PJ,y} = FC_{fuel\ oil,PJ,y}^m \times NCV_{fuel\ oil,y}, \quad (D.1-5)$$

where  $FC_{fuel\ oil,PJ,y}^m$  is the project mass consumption of heavy fuel oil in CHPP-1 during the year  $y$  (this value is to be monitored), t;

$NCV_{fuel\ oil,y}$  is the average net calorific value of heavy fuel oil under the project during the year  $y$  (this value is to be monitored), GJ/t.

$$PE_{BWW\ comb.,y} = PE_{bark\ comb.,y} + PE_{sd+spw\ comb.,y}; \quad (D.1-6)$$

$$PE_{sd+spw\ comb.,y} = (FC_{sd+spw,PJ,y}^v - FC_{sd+spw,BL,y}^v) \times NCV_{sd+spw}^{av} \times (EF_{CH_4,BWW\ comb.} \times GWP_{CH_4} + EF_{N_2O,BWW\ comb.} \times GWP_{N_2O}) \times 10^{-3}; \quad (D.1-7)$$

$$PE_{bark\ comb.,y} = FC_{bark,PJ,y}^v \times NCV_{bark}^{av} \times (EF_{CH_4,BWW\ comb.} \times GWP_{CH_4} + EF_{N_2O,BWW\ comb.} \times GWP_{N_2O}) \times 10^{-3}, \quad (D.1-8)$$

where  $PE_{sd+spw\ comb.,y}$  is the emissions of N<sub>2</sub>O and CH<sub>4</sub> from combustion of additional amount of sawdust and chip screenings under the project as compared with the baseline scenario during the year  $y$ , tCO<sub>2</sub>e;

$PE_{bark\ comb.,y}$  is the emissions of N<sub>2</sub>O and CH<sub>4</sub> from combustion of additional amount of bark under the project as compared with the baseline scenario during the year  $y$ , tCO<sub>2</sub>e;

$NCV_{sd+spw}^{av}$  is the average net calorific value of sawdust and chip screenings, GJ/dense m<sup>3</sup>.  $NCV_{sd+spw}^{av} = 5.724$  GJ/dense m<sup>3</sup> (See Section B.1.);



$NCV_{bark}^{av}$  is the average net calorific value of bark, GJ/dense m<sup>3</sup>.  $NCV_{bark}^{av} = 5.612$  GJ/dense m<sup>3</sup> (See Section B.1.);

$GWP_{CH_4}$  is the global warming potential of CH<sub>4</sub>, tCO<sub>2</sub>e/tCH<sub>4</sub>. In accordance with [R2]:  $GWP_{CH_4} = 21$  tCO<sub>2</sub>e/tCH<sub>4</sub>;

$GWP_{N_2O}$  is the global warming potential of N<sub>2</sub>O, tCO<sub>2</sub>e /tN<sub>2</sub>O. In accordance with [R2]:  $GWP_{CH_4} = 310$  tCO<sub>2</sub>e/tN<sub>2</sub>O;

$EF_{CH_4,BWW comb.}$  is the CH<sub>4</sub> emission factor for BWW, kg CH<sub>4</sub>/GJ. In accordance with [R5]:  $EF_{CH_4,BWW comb.} = 0.030$  kg CH<sub>4</sub>/TJ;

$EF_{N_2O,BWW comb.}$  is the N<sub>2</sub>O emission factor for BWW, kg N<sub>2</sub>O /GJ. In accordance with [R5]:  $EF_{CH_4,BWW comb.} = 0.004$  kg N<sub>2</sub>O/TJ;

$FC_{bark,PJ,y}^v$  is the volumetric consumption of bark in CHPP-1 under the project during the year  $y$  (this value is to be monitored), dense m<sup>3</sup>;

$FC_{sd+spw,PJ,y}^v$  is the volumetric consumption of sawdust and chip screenings in CHPP-1 under the project during the year  $y$ , dense m<sup>3</sup>.

$$FC_{sd+spw,PJ,y}^v = FC_{sd,PJ,y}^v + FC_{spw,PJ,y}^v, \quad (D.1-9)$$

where  $FC_{sd,PJ,y}^v$  is the volumetric consumption of sawdust in CHPP-1 under the project during the year  $y$  (this value is to be monitored), dense m<sup>3</sup>;

$FC_{spw,PJ,y}^v$  is the volumetric consumption of chip screenings in CHPP-1 under the project during the year  $y$  (this value is to be monitored), dense m<sup>3</sup>.

$FC_{sd+spw,BL,y}^v$  is the volumetric consumption of sawdust and chip screenings in CHPP-1 under the baseline scenario during the year  $y$ , kg/dense m<sup>3</sup>;

$$FC_{sd+spw,BL,y}^v = \frac{HG_{1,sd+spw,BL,y}}{SHG_{sd+spw}^{\max}}, \quad (D.1-10)$$

where  $SHG_{sd+spw}^{\max}$  is the maximum average annual specific heat production from sawdust and chip screenings in CHPP-1 recorded during three years (2000-2002) prior to commissioning of replaced boiler No.5, GJ/dense m<sup>3</sup>. Recorded in 2000 and amounts to  $SHG_{sd+spw}^{\max} = 4.514$  GJ/dense m<sup>3</sup> (See Table B.1-1);



$HG_{1, sd+spw, BL, y}$  is the heat production by boiler No.1 from sawdust and chip screenings under the baseline scenario during the year  $y$ , GJ;

$$HG_{1, sd+spw, BL, y} = \text{MIN} \left\{ \frac{SG_1^{nom} \times T_1^{max} \times (h_s - h_{FW})}{1000} \times (1 - f_1^{min}); FC_{sd+spw, PJ, y}^v \times SHG_{sd+spw}^{max} \right\}, \quad (D.1-11)$$

where  $SG_1^{nom}$  is the nominal steam output of boiler No.1, tonnes of steam per hour. According to the nameplate data of the boiler  $SG_1^{nom} = 40$  tonnes of steam per hour;

$T_1^{max}$  is the maximum annual number of running hours of boiler No.1, h. In accordance with the data on operation of boiler No.1 in 2000-2009 the maximum annual number of running hours of the boiler was assumed at  $T_1^{max} = 8100$  h;

$h_s$  is the heat content of fresh steam at nominal parameters, kJ/kg. At pressure 3.9 MPa and temperature 440 °C the heat content is  $h_s = 3309$  kJ/kg;

$h_{FW}$  is the heat content of feed water at nominal parameters, kJ/kg. At the feed water temperature of 145 °C its heat content is  $h_{FW} = 612$  kJ/kg;

$f_1^{min}$  is the minimum proportion of heavy fuel oil used for fame stabilization in boiler No.1. According to the operational data and proceeding from conservative assumptions  $f_1^{min} = 0.25$ .

D.1.1.3. Relevant data necessary for determining the <u>baseline</u> of anthropogenic emissions of greenhouse gases by sources within the project boundary, and how such data will be collected and archived:								
ID number (Please use numbers to ease cross-referencing to D.2.)	Data variable	Source of data	Data unit	Measured (m), calculated (c), estimated (e)	Recording frequency	Proportion of data to be monitored	How will the data be archived? (electronic/ paper)	Comment
8. $HG_{CHPP-1, PJ, y}$	Total heat production by boilers of CHPP-1	Department of Chief Power Engineer	GJ	m, c	Continuously	100%	Electronic and paper	Readings of heat production meters



9. $FC_{coal,PJ,y}^m$	Mass consumption of coal in CHPP-1	Department of Chief Power Engineer	t	m	Continuously	100%	Electronic and paper	Weight and balance methods and the suppliers' data are used
10. $FC_{fuel\ oil,PJ,y}^m$	Mass consumption of heavy fuel oil in CHPP-1	Department of Chief Power Engineer	t	m	Continuously	100%	Electronic and paper	Readings of flow meters, balance method
11. $NCV_{coal,y}$	Average net calorific value of coal	Department of Chief Power Engineer	GJ/t	m	Each batch of fuel	100%	Electronic and paper	Fuel suppliers' certificates
12. $NCV_{fuel\ oil,y}$	Average net calorific value of heavy fuel oil	Department of Chief Power Engineer	GJ/t	m	Each batch of fuel	100%	Electronic and paper	Fuel suppliers' certificates
13. $FC_{sd,PJ,y}^v$	Volumetric consumption of sawdust in CHPP-1	Department of Chief Power Engineer	dense m <sup>3</sup>	e	Monthly	100%	Electronic and paper	Results of inventory of the quantities remaining in stock
14. $FC_{spw,PJ,y}^v$	Volumetric consumption of chip screenings in CHPP-1	Department of Chief Power Engineer	dense m <sup>3</sup>	e	Monthly	100%	Electronic and paper	Results of inventory of the quantities remaining in stock
15. $FC_{bark,PJ,y}^v$	Volumetric consumption of bark in CHPP-1	Department of Chief Power Engineer	dense m <sup>3</sup>	e	Monthly	100%	Electronic and paper	Results of inventory of the quantities remaining in stock

**D.1.1.4. Description of formulae used to estimate baseline emissions (for each gas, source etc.; emissions in units of CO<sub>2</sub> equivalent):**

The baseline GHG emissions are determined as a sum of emissions from combustion of fossil fuel (coal and heavy fuel oil) in CHPP-1 for heat production and prevented emissions from decomposition of bark, sawdust and chip screenings at dumps during the year y, tCO<sub>2</sub>e:

$$BE_y = BE_{coal,y} + BE_{fuel\ oil,y} + BE_{bark,y} + BE_{sd+spw,y} \quad (D.1-12)$$



where  $BE_{coal,y}$  is the baseline emissions of CO<sub>2</sub> due to coal combustion in CHPP-1 during the year  $y$ , tCO<sub>2</sub>e;

$BE_{fuel\ oil,y}$  is the baseline emissions of CO<sub>2</sub> due to combustion of heavy fuel oil in CHPP-1 during the year  $y$ , tCO<sub>2</sub>e;

$BE_{bark,y}$  is the prevented (due to the project) emissions of CH<sub>4</sub> from decomposition of bark at dumps during the year  $y$ , tCO<sub>2</sub>e;

$BE_{sd+spw,y}$  is the prevented (due to the project) emissions of CH<sub>4</sub> from decomposition of sawdust and chip screenings at dumps during the year  $y$ , tCO<sub>2</sub>e.

$$BE_{coal,y} = FC_{coal,BL,y} \times EF_{CO_2,coal} \quad (D.1-13)$$

where  $FC_{coal,BL,y}$  is the baseline consumption of coal in CHPP-1 during the year  $y$ , GJ.

$$FC_{coal,BL,y} = MAX \{ MIN [A; B; C; D]; E \}, \quad (D.1-14)$$

where  $A$  is the consumption of coal during the year  $y$ , calculated on the assumption that the baseline heavy fuel oil consumption in CHPP-1 is equal to the project heavy fuel oil consumption during the year  $y$ , GJ;

$B$  is the minimum annual coal consumption recorded in CHPP-1 during three years prior to commissioning of replaced boiler No.5, GJ;

$C$  is the coal consumption during the year  $y$ , calculated on the assumption that the average annual proportion of heavy fuel oil in the overall consumption of heavy fuel oil and coal at CHPP-1 under the baseline scenario is equal to the maximum average annual proportion of heavy fuel oil recorded during three years prior to commissioning of replaced boiler No.5, GJ;

$D$  is the consumption of coal during the year  $y$ , calculated on the assumption that the average annual proportion of heavy fuel oil in the overall consumption of heavy fuel oil and coal in CHPP-1 under the baseline scenario is equal to that of the project scenario during the year  $y$ , GJ;

$E$  is the coal consumption in CHPP-1 under the project during the year  $y$ , GJ.

$$A = \left( HG_{CHPP-1,BL,y} - HG_{1,sd+spw,BL,y} - FC_{fuel\ oil,PJ,y} \times \eta_{fuel\ oil} \right) \times \frac{1}{\eta_{coal}}, \quad (D.1-15)$$

where  $HG_{CHPP-1,BL,y}$  is the total heat production by CHPP-1 boilers under the baseline scenario during the year  $y$ , GJ.

$HG_{1,sd+spw,BL,y}$  is the heat production by boiler No.1 from sawdust and chip screenings under the baseline scenario during the year  $y$ , GJ;



$\eta_{fuel\ oil}$  is the efficiency of heavy fuel oil combustion in CHPP-1 boilers. In accordance with the recommendations [R6]

$$\eta_{fuel\ oil} = 0.85;$$

$\eta_{coal}$  is the efficiency of coal combustion in CHPP-1 boilers. In accordance with the recommendations [C6]  $\eta_{coal} = 0.8$ .

$$HG_{CHPP-1,BL,y} = HG_{CHPP-1,PJ,y}, \quad (D.1-16)$$

where  $HG_{CHPP-1,PJ,y}$  is the total heat production by CHPP-1 boilers under the project during the year  $y$  (this value is monitored), GJ.

$$B = FC_{coal}^{\min}, \quad (D.1-17)$$

where  $FC_{coal}^{\min}$  is the minimum annual consumption of coal in CHPP-1 recorded during three years (2000-2002) prior to commissioning of replaced boiler No.5, GJ. Recorded in 2000 and amounts to  $FC_{coal}^{\min} = 1\ 290\ 138$  GJ (See Table B.1-1).

$$C = \left( HG_{CHPP-1,BL,y} - HG_{1,sd+spw,BL,y} - \frac{HG_{CHPP-1,BL,y} - HG_{1,sd+spw,BL,y}}{1 + \frac{1 - \alpha_{\max}}{\alpha_{\max}} \times \frac{\eta_{coal}}{\eta_{fuel\ oil}}} \right) \times \frac{1}{\eta_{coal}}, \quad (D.1-18)$$

where  $\alpha_{\max}$  is the maximum proportion of heavy fuel oil in the overall consumption of heavy fuel oil and coal in CHPP-1 recorded during three years (2000-2002) prior to commissioning of replaced boiler No.5. Recorded in 2000 and amounted to  $\alpha_{\max} = 0.5929$  (See Table B.1-1).

$$D = \left( HG_{CHPP-1,BL,y} - HG_{1,sd+spw,BL,y} - \frac{HG_{CHPP-1,BL,y} - HG_{1,sd+spw,BL,y}}{1 + \frac{1 - \alpha_{PJ,y}}{\alpha_{PJ,y}} \times \frac{\eta_{coal}}{\eta_{fuel\ oil}}} \right) \times \frac{1}{\eta_{coal}}, \quad (D.1-19)$$

where  $\alpha_{PJ,y}$  is the proportion of heavy fuel oil in the overall consumption of heavy fuel oil and coal in CHPP-1 under the project during the year  $y$ .

$$\alpha_{PJ,y} = \frac{FC_{fuel\ oil,PJ,y}}{FC_{fuel\ oil,PJ,y} + FC_{coal,PJ,y}} \quad (D.1-20)$$

$$E = FC_{coal,PJ,y} \quad (D.1-21)$$

$$BE_{fuel\ oil,y} = FC_{fuel\ oil,BL,y} \times EF_{CO_2,fuel\ oil} \quad (D.1-22)$$

where  $FC_{fuel\ oil,BL,y}$  is the consumption of heavy fuel oil in CHPP-1 under the baseline scenario during the year  $y$ , GJ.

$$FC_{fuel\ oil,BL,y} = \frac{HG_{fuel\ oil,BL,y}}{\eta_{fuel\ oil}} \quad (D.1-23)$$

where  $HG_{fuel\ oil,BL,y}$  is the heat production by CHPP-1 boilers from heavy fuel oil under the baseline scenario during the year  $y$ , GJ.

$$HG_{fuel\ oil,BL,y} = HG_{CHPP-1,BL,y} - HG_{1,sd+spw,BL,y} - HG_{coal,BL,y} \quad (D.1-24)$$

where  $HG_{coal,BL,y}$  is the heat production in CHPP-1 from coal under the baseline scenario during the year  $y$ , GJ.

$$HG_{coal,BL,y} = FC_{coal,BL,y} \times \eta_{coal} \quad (D.1-25)$$

Numerical values of  $BE_{bark,y}$  and  $BE_{sd+spw,y}$  are determined using the model ‘‘Calculation of CO<sub>2</sub>-equivalent emission reduction from biomass prevented from stockpiling or taken from stockpiles’’ developed by ‘‘BTG biomass technology group B.V.’’ in accordance with [R2]:

$$BE_{bark,y} = \left(1 - w_{lignin,BWW}\right) \times k_{BWW} \times \frac{C_{BWW}^d}{100} \times \left(1 - \frac{M_{bark}}{100}\right) \times a \times \zeta \times \left(1 - \frac{\varphi}{100}\right) \times \left(1 - \zeta_{OX}\right) \times \frac{V_m}{100} \times \rho_{CH_4} \times GWP_{CH_4} \times \sum_{x=2003}^{x=y} \left(W_{bark,x} \times e^{-k_{BWW} \times (y-x)}\right) \quad (D.1-26)$$



$$BE_{sd+spw,y} = \left(1 - w_{lignin,BWW}\right) \times k_{BWW} \times \frac{C_{BWW}^d}{100} \times \left(1 - \frac{M_{sd+spw}}{100}\right) \times a \times \zeta \times \left(1 - \frac{\varphi}{100}\right) \times \left(1 - \zeta_{OX}\right) \times \frac{V_m}{100} \times \rho_{CH_4} \times GWP_{CH_4} \times \sum_{x=2003}^{x=y} \left(W_{sd+spw,x} \times e^{-k_{BWW} \times (y-x)}\right) \quad (D.1-27)$$

where  $W_{bark,x}$  is the quantity of bark prevented from stockpiling as a result of the project during the year  $x$ , t;

$W_{sd+spw,x}$  is the quantity of sawdust and chip screenings prevented from stockpiling as a result of the project during the year  $x$ , t;

$M_{bark}$  is the moisture content of bark, %. We assumed the recommended default value [R2]:  $M_{bark} = 50\%$ ;

$M_{sd+spw,x}$  is the moisture content of sawdust and chip screenings, %. We assumed the recommended default value [R2]:

$M_{sd+spw,x} = 50\%$ ;

$w_{lignin,BWW}$  is the lignin fraction in C (carbon) for bark and wood wastes. We assumed the recommended default value [R2]:

$w_{lignin,BWW} = 0.25$ ;

$k_{BWW}$  is the decomposition rate constant for bark and wood wastes, year<sup>-1</sup>. We assumed the recommended default value [R2]:

$k_{BWW} = -\ln(1/2)/15 = 0.0462 \text{ year}^{-1}$  (where 15 is the recommended default value for half period of wood, years);

$C_{BWW}^d$  is the the organic carbon content in BWW on dry basis, %. We assumed the recommended default value [R2]:  $C_{BWW}^d = 53.6\%$ ;

$a$  is the conversion factor for kg carbon to volume of biogas, m<sup>3</sup>/kg carbon. We assumed the recommended default value [R2]:  $a = 1.87 \text{ m}^3/\text{kg}$ ;

$\zeta$  is the generation factor. We assumed the recommended default value [R2]:  $\zeta = 0.77$ ;

$\varphi$  is the percentage of the stockpile under aerobic conditions, %. We assumed the recommended default value [R2]:  $\varphi = 10\%$ ;

$\zeta_{OX}$  is the methane oxidation factor. We assumed the recommended default value [R2]  $\zeta_{OX} = 0.10$ ;

$V_m$  is the methane concentration biogas, %. In accordance with Section B.1 we assumed  $V_m = 50\%$ , which is a more conservative value than the one recommended by [R2] on default ( $V_m = 60\%$ );





$\rho_{CH_4}$  is the density of methane, kg/m<sup>3</sup>. In accordance with [R2] we assumed:  $\rho_{CH_4} = 16.04/22.4 = 0.716$  kg/m<sup>3</sup>;

$GWP_{CH_4}$  is the Global Warming Potential for methane, tCO<sub>2</sub>e/tCH<sub>4</sub>. In accordance with [R2]:  $GWP_{CH_4} = 21$  tCO<sub>2</sub>e/tCH<sub>4</sub>;

y is the year for which to calculate the CO<sub>2</sub>-equivalent reduction, year;

x is the year in which fresh biomass is utilized instead of stockpiled, year (starting in 2003).

$$W_{bark,x} = FC_{bark,PJ,x}^v \times \frac{\rho_{bark}}{1000} \quad (D.1-28)$$

where  $\rho_{bark}$  is the density of moist bark, kg/dense m<sup>3</sup>.

The density of moist bark (for pine at moisture content over 23%) is calculated in accordance with the methodology laid out in [R4] by the following formula, kg/dense m<sup>3</sup>:

$$\rho_{bark} = \frac{100}{1.231 \times (100 - M_{bark})} \times \rho_{12,bark} \quad (D.1-29)$$

where  $\rho_{12,bark}$  is the density of bark at standard moisture content (i.e. at absolute moisture content of 12%), kg/dense m<sup>3</sup>. In accordance with [R4]  $\rho_{12,bark} = 680$  kg/dense m<sup>3</sup> (for pine).

$$W_{sd+spw,x} = (FC_{sd+spw,PJ,x}^v - FC_{sd+spw,BL,x}^v) \times \frac{\rho_{sd+spw}}{1000}, \quad (D.1-30)$$

where  $\rho_{sd+spw}$  is the density of moist saw dust and chip screenings, kg/dense m<sup>3</sup>.

The density of moist sawdust and chip screenings (for pine at moisture content over 23%) is calculated in accordance with the methodology laid out in [R4] by the following formula, kg/dense m<sup>3</sup>:

$$\rho_{sd+spw} = 0.823 \times \frac{100}{100 - M_{sd+spw}} \times \rho_{12,sd+spw}, \quad (D.1-31)$$



where  $\rho_{12, sd+spw}$  is the density of sawdust and chip screenings at standard moisture content (i.e. at absolute moisture content of 12%), kg/dense m<sup>3</sup>. In accordance with [R4]  $\rho_{12, sd+spw} = 500$  kg/dense m<sup>3</sup> (for pine).

**D. 1.2. Option 2 – Direct monitoring of emission reductions from the project (values should be consistent with those in section E.):**

This option is not applied.

**D.1.2.1. Data to be collected in order to monitor emission reductions from the project, and how these data will be archived:**

ID number (Please use numbers to ease cross-referencing to D.2.)	Data variable	Source of data	Data unit	Measured (m), calculated (c), estimated (e)	Recording frequency	Proportion of data to be monitored	How will the data be archived? (electronic/ paper)	Comment

**D.1.2.2. Description of formulae used to calculate emission reductions from the project (for each gas, source etc.; emissions/emission reductions in units of CO<sub>2</sub> equivalent):**

This option is not applied.

**D.1.3. Treatment of leakage in the monitoring plan:**

As shown in Section B.1, leakage is assumed equal to zero.

**D.1.3.1. If applicable, please describe the data and information that will be collected in order to monitor leakage effects of the project:**

ID number (Please use numbers to ease cross-referencing to D.2.)	Data variable	Source of data	Data unit	Measured (m), calculated (c), estimated (e)	Recording frequency	Proportion of data to be monitored	How will the data be archived? (electronic/ paper)	Comment

**D.1.3.2. Description of formulae used to estimate leakage (for each gas, source etc.; emissions in units of CO<sub>2</sub> equivalent):**

As shown in Section B.1, leakage is assumed equal to zero.

**D.1.4. Description of formulae used to estimate emission reductions for the project (for each gas, source etc.; emissions/emission reductions in units of CO<sub>2</sub> equivalent):**

The GHG emission reduction during the year  $y$  is determined as a difference between the baseline emissions and the project emissions, tCO<sub>2</sub>e:

$$ER_y = BE_y - PE_y, \quad (D.1-32)$$

where  $BE_y$  is the baseline emissions of GHG during the year  $y$ , tCO<sub>2</sub>e;

$PE_y$  is the project emissions of GHG during the year  $y$ , tCO<sub>2</sub>e.

**D.1.5. Where applicable, in accordance with procedures as required by the host Party, information on the collection and archiving of information on the environmental impacts of the project:**

The industrial environmental monitoring at the Mill is the responsibility of the Environment Protection, Occupational and Industrial Safety Service.

The industrial environmental monitoring programme, which is currently implemented by the Mill, will not undergo any significant changes after the project completion and will be fulfilled according to the scheme and schedules approved by the Natural Resources Committee of the Arkhangelsk Region.

Similar to the way it is now, the monitoring will be carried out by the Environment Protection Service of the Mill.

The industrial environmental monitoring covers the following:

- Analytical control of compliance with the prescribed pollutant emission standards in accordance with the laboratory control charts;
- Monitoring of the impact of waste disposal sites on underground and surface waters, atmospheric air and soil;
- Control of pollutants content in the atmospheric air on the border of the sanitary protection zone, etc.

The enterprise has the following reporting obligations as per official annual statistic forms:

- 2-tp (air) Data on Atmospheric Air containing information on the quantities of trapped and destroyed air pollutants, detailed emissions of specific pollutants, number of emission sources, emission reduction actions and emissions from separate groups of pollutant sources;
- 2-tp (water) Data on Water Use, containing information on water consumption from natural sources, discharges of effluents and their pollutant content, capacity of wastewater treatment facilities, etc.;



- 2-tp (wastes) Data on generation, use, decontamination, transportation and disposal of industrial and consumption wastes which shows annual balance of waste flows with breakdown by type and hazard class.

In accordance with the Russian legislation the Mill develops and implements environment protection actions on an annual basis.

International Standard ISO 9001 is operational at the Mill.

The monitoring systems of Solombala PPM comply with national standards:

- Federal Law No.102-FZ "On measurements uniformity assurance" dated 26.06.2008;
- "Rules for electricity metering" dated September 26, 1996;
- RD 34.09.102 "Rules for heat metering" dated 31.08.1995.

<b>D.2. Quality control (QC) and quality assurance (QA) procedures undertaken for data monitored:</b>		
Data (Indicate table and ID number)	Uncertainty level of data (high/medium/low)	Explain QA/QC procedures planned for these data, or why such procedures are not necessary.
Table D.1.1.1 ID 1, Table D.1.1.3 ID 9	Low	The mass consumption of coal is measured with the help of weighs installed at the belt conveyor which supplies coal for combustion to CHPP-1 boilers.  The weighs are regularly calibrated in accordance with the schedule and procedure for checking of instrumentation and control equipment adopted at the Mill. Moreover, for the sake of cross-check, coal consumption is also estimated using a reverse balance method based on heat output by coal-fired boilers and is compared with the coal suppliers' data.
Table D.1.1.1 ID 2, Table D.1.1.3 ID 10	Low	The mass consumption of heavy fuel oil is measured by flow meters.  The flow meters are regularly checked in accordance with the schedule and procedure for checking of instrumentation and control equipment adopted at the Mill.  For the sake of cross-check, the consumption of heavy fuel oil is also estimated using a reverse balance method based on heat output by boilers.
Table D.1.1.1 ID 3, 4, Table D.1.1.3 ID 11, 12	Low	Data provided by the certified laboratories of the suppliers are used.  At the year end an average value is determined.



<p>Table D.1.1.1 ID 5, 6, 7, Table D.1.1.3 ID 13,14,15</p>	<p>Low</p>	<p>At the end of each month the Chief Power Engineer forms a committee consisting of representatives of CHPP-1, the Repairs Department and “Solombalales” Management Company in order to determine the remaining amount of bark and wood wastes at the bark and sawdust storages near chip buffers, of sawdust at the timber yard.</p> <p>Based on the results of the inspection the Committee draws up a Protocol. Based on the Protocol and Feed Stock Supply Reports, the weight-point man of CHPP-1 executes bark and wood waste fuel flow certificates, in which consumption of bark, sawdust and chip screenings is estimated based on the remaining quantities as of the beginning and end of month, as well as based on feedstock supply in the previous month.</p>
<p>Table D.1.1.3 ID 8</p>	<p>Low</p>	<p>In order to monitor heat output by CHPP-1 boilers the steam flow meters, temperature and pressure gauges are used. Measuring devices are regularly checked in accordance with the schedule and procedure for checking of instrumentation and control equipment adopted at the Mill.</p> <p>All current signals from the measuring devices are sent to the automated management system Damatic, where heat output is automatically calculated.</p>

**Actions undertaken during calibration of measuring instruments**

The measuring instruments are calibrated during the periods of scheduled shutdown of the equipment. If necessary the removed measuring device is replaced with a backup calibrated instrument. Operation of the equipment without instrumentation and control equipment is not allowed.

**Troubleshooting procedure**

If the measurement processes do not comply with the standards specified in the design documentation the situation shall be analyzed, alternative monitoring and measuring procedures shall be developed for the period of non-compliance, as well as corrective actions which allow to remedy the identified non-compliance.

If any measuring instrument fails, the parameter shall be metered with the help of a duplicate instrument or if there is no duplicate instrument, the failed device is substituted by a backup calibrated instrument. Operation of the equipment without instrumentation and control equipment is not allowed.

**Cross-check**

The primary check of the project monitoring report is carried out by the Director of the Project Implementation Department of CCGS LLC or, on his instructions, by a specialist of the same Department who is not directly involved in preparation of this report.

Additional cross-check is made by the Director of the Project Development Department of CCGS LLC or, on his instructions, by another specialist of this Department.

As soon as all comments made by the Project Development Department are closed, the monitoring report is submitted for internal check out to the company that implements the project.

**Internal check**

Internal check by the company includes checking primary data provided to CCGS LLC during information collection period as well as checking the project monitoring reports.

**Test verifications**

Regularly, but not more than once per year, specialists of CCGS LLC shall carry out test verifications with a view to verifying the observance of the monitoring plan.

**D.3. Please describe the operational and management structure that the project operator will apply in implementing the monitoring plan:****Information transfer**

The initial request for input monitoring data is made by the Director of the Project Implementation Department of CCGS LLC to the Head of the Environment Protection, Occupational and Industrial Safety Service of OJSC “Solombala PPM”, who in his turn gives instructions to collect the required data. At the company there is a set of people (working group) responsible for collection, control and transfer of monitoring data. The responsibility of these persons is stipulated in corresponding orders.

The information collected at the enterprise is transferred to the Head of the Environment Protection, Occupational and Industrial Safety Service of OJSC “Solombala PPM”, who in his turn transfers it further to the Director of the Project Implementation Department of CCGS LLC. All information is transferred via email.

Based on the received data, the Project Implementation Department of CCGS LLC prepares a project monitoring report and submits it for additional cross-check to the Project Development Department of CCGS LLC. As soon as all comments made by the Project Development Department have been incorporated the project monitoring report is transferred to the company where the project is implemented.

At CCGS LLC the procedures for checking the project monitoring reports are laid out in the “CCGS LLC’s internal regulation on the procedure for quality control of the project documentation and monitoring reports developed for GHG emission reduction projects”.

After checking and making required corrections to the report, the Director of the Project Implementation Department at CCGS LLC shall inform the Head of the Environment Protection, Occupational and Industrial Safety Service of OJSC “Solombala PPM” about the preliminary results of monitoring and if there are no objections on his part, the Director General of CCGS LLC makes a final decision to submit the project monitoring report for verification by an independent auditor.

**Registration and collection of monitoring data**

The information required for calculation of GHG emission reductions is collected in accordance with the procedures for resources monitoring and accounting adopted at the company.



The location of the monitoring points is shown in Fig. D.4-1.

The procedure for collection and transfer of information necessary for fulfilment of the project monitoring plan is shown in Fig. D.4-2.

The procedures for primary data registration and storage as well as persons responsible for monitoring are specified in Table D.4-1.

The GHG emission reductions are calculated at the end of each reporting period by CCGS LLC specialists.

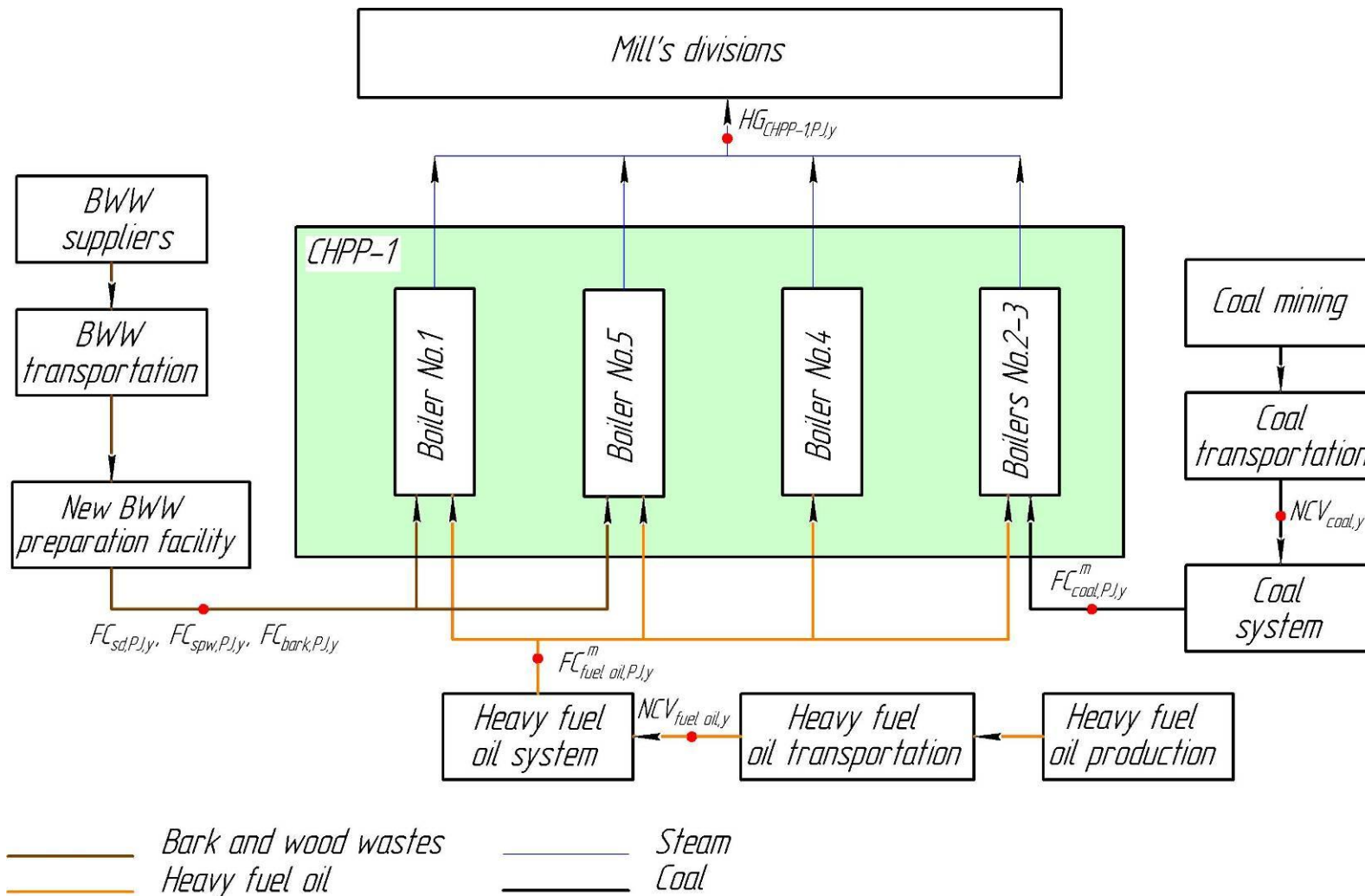

Fig. D.4-1. Location of the monitoring points



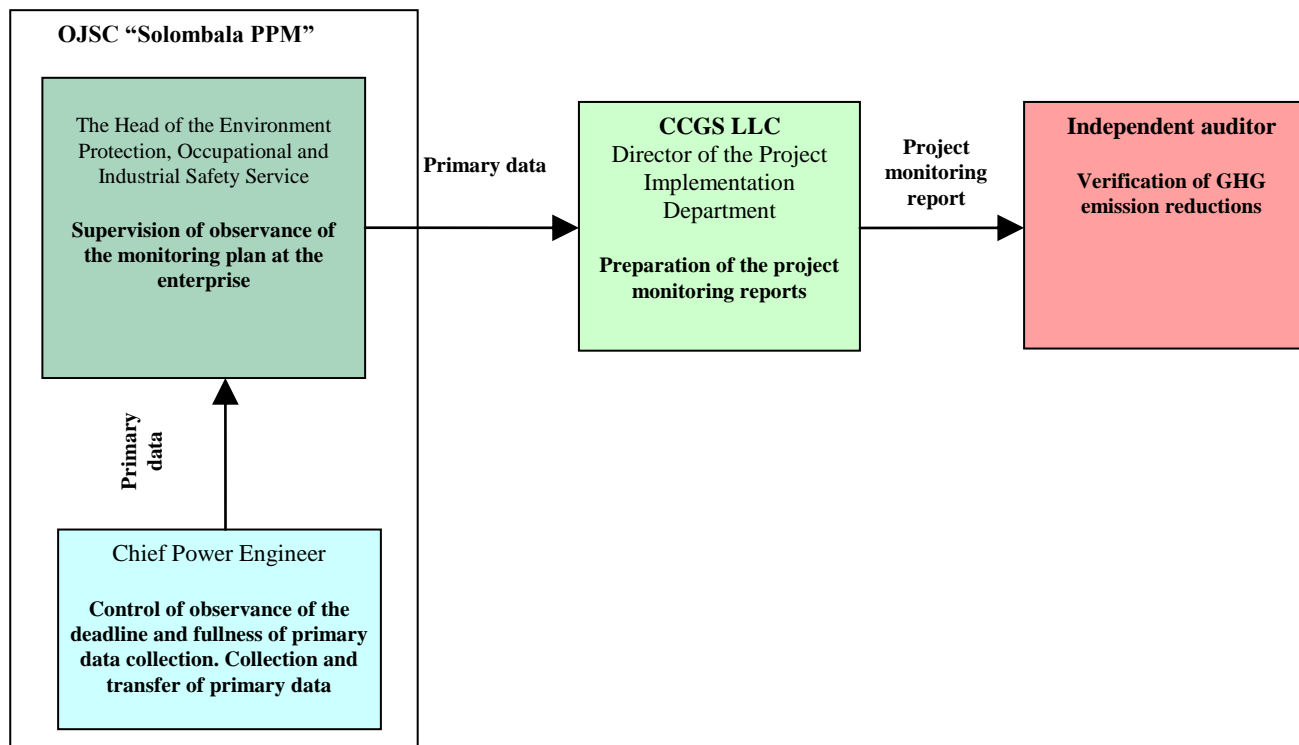

Fig. D.4-2. Organization of collection and transfer of monitoring information



**Table D.4-1. Monitoring procedures**

Monitored parameter	Procedure for registration, monitoring, record and storage of data (including everyday monitoring)	Person responsible for monitoring
Heat production by CHPP-1 boilers	<ol style="list-style-type: none"> <li>For monitoring of heat production sensors and transmitters are used, which continuously measure flow rate, temperature and pressure of steam.</li> <li>Readings of the measuring devices are recorded in the automated control system Damatic and are shown on the displays of all computers which have the required software. The data are printed out on paper and are stored in the computer memory.</li> <li>Data are recorded on a daily basis by operators in daily logs and are then summarized in monthly and annual reports.</li> <li>Data on heat production and supply shall be stored in the Mill's archive in electronic and hard copy for at least two years after the end of the crediting period or after the last issue of ERUs.</li> </ol>	Chief Power Engineer
Quantity of heavy fuel oil consumed by CHPP-1 boilers	<ol style="list-style-type: none"> <li>The quantity of consumed heavy fuel oil is continuously measured by flow meters. Furthermore, this quantity is cross-checked using the method of reverse balance based on steam output by boilers.</li> <li>Readings of flow meters are recorded by operator in a special log, submitted on a daily basis to the Chief Power Engineer Department and entered into the electronic database.</li> <li>Data on heavy fuel oil consumption shall be stored in the Mill's archive in electronic and hard copy for at least two years after the end of the crediting period or after the last issue of ERUs.</li> </ol>	Chief Power Engineer
Quantity of coal consumed by CHPP-1 boilers	<ol style="list-style-type: none"> <li>The quantity of consumed coal is measured by weighs installed at the belt conveyor which feeds coal for combustion. Besides, this quantity is cross-checked using the method of reverse balance based on steam output by boilers.</li> <li>Readings of weighs are recorded by operator in special logs, daily transferred to the Chief Power Engineer Department, entered into the electronic database.</li> <li>Data on coal consumption shall be stored in the Mill's archive in electronic and hard copy for at least two years after the end of the crediting period or after the last issue of ERUs.</li> </ol>	Chief Power Engineer
Quantity of BWW (sawdust, bark, chip screenings) consumed by CHPP-1 boilers	<ol style="list-style-type: none"> <li>The consumption of bark, sawdust and chip screenings are determined based on the feedstock supply reports made by a weigh-point man of CHPP-1 and a monthly protocol of the expert committee on the remaining quantities in storehouses.</li> <li>At the end of each month the Chief Power Engineer organizes a committee consisting of</li> </ol>	Weigh-point man of CHPP-1



	<p>representatives of CHPP-1, Equipment Repair Department and management company “Solombalales” with a view to estimating remaining quantities of bark and wood waste fuel at bark and sawdust storages near chip buffers, and sawdust timber yards.</p> <ol style="list-style-type: none"> <li>3. Based on the results of the inspection, the committee draws up a protocol. Based on the protocol and feedstock supply reports, the weigh-point man of CHPP-1 executes bark and wood waste flow protocols, in which the consumption of bark, sawdust and chip screenings is estimated based on the remaining quantities as of the beginning and end of month and based on the feedstock supply in the previous month.</li> <li>4. Data of BWW supply reports and results of monthly audit of remaining quantities of BWW in the storehouses are entered into the electronic database.</li> <li>5. BWW consumption data shall be kept in the Mill’s archive in electronic and hard copy for at least two years after the end of the crediting period or the last transfer of ERUs under the project.</li> </ol>	
<p>Calorific values of coal and heavy fuel oil</p>	<ol style="list-style-type: none"> <li>1. Calorific values of heavy fuel oil and coal are identified by certified laboratories of the fuel suppliers, fuel certificates are provided for each batch of heavy fuel oil and coal delivered to the Mill.</li> <li>2. Calorific value data are recorded in logs and are transferred to the Chief Power Engineer Department, and entered into electronic database.</li> <li>3. Information on calorific values shall be kept in the Mill’s archive in electronic and hard copy for at least two years after the end of the crediting period or the last issue of ERUs.</li> </ol>	<p>The Chief Power Engineer</p>

The integrated quality and environmental management system meets the requirements of national standards:

- Federal Law No.102-FZ "On measurements uniformity assurance" dated 26.06.2008;
- “Rules for electricity metering” dated September 26, 1996;
- RD 34.09.102 “Rules for heat metering” dated 31.08.1995.

System is functioning at the enterprise and is being constantly improved. This system is applicable to the monitoring plan described.

**D.4. Name of person(s)/entity(ies) establishing the monitoring plan:**

The monitoring plan was developed by CCGS LLC (CCGS LLC is not a project participant and is not listed in Annex 1 to this PDD).

The contact person: Dmitry Potashev

E-mail: d.potashev@ccgs.ru

**SECTION E. Estimation of greenhouse gas emission reductions**

The emission reductions were estimated by the formulae in accordance with the methodology described in detail in Section B.1. In the same section all necessary input data are given in a tabular form. Below are the results of the emissions estimation for both scenarios with breakdown by sources for the period 2008-2012.

**E.1. Estimated project emissions:****Table E.1-1. Project GHG emissions, tCO<sub>2</sub>e**

Parameter	2008	2009	2010	2011	2012	2008-2012
<b>GHG emissions, total</b>	<b>122 883</b>	<b>128 492</b>	<b>132 666</b>	<b>132 666</b>	<b>132 666</b>	<b>649 374</b>
CO <sub>2</sub> from combustion, total	120 657	126 860	129 323	129 323	129 323	635 485
CO <sub>2</sub> from heavy fuel oil combustion	41 876	44 452	58 195	58 195	58 195	260 913
CO <sub>2</sub> from coal combustion	78 781	82 408	71 127	71 127	71 127	374 572
NO <sub>2</sub> and CH <sub>4</sub> from combustion of additional BWW, total	2 226	1 632	3 344	3 344	3 344	13 889
NO <sub>2</sub> and CH <sub>4</sub> from bark combustion	1 492	984	1 492	1 492	1 492	6 954
NO <sub>2</sub> and CH <sub>4</sub> from combustion of additional sawdust and chip screenings	734	647	1 851	1 851	1 851	6 935

**E.2. Estimated leakage:**

Leakages are considered to be zero.

**E.3. The sum of E.1. and E.2.:**

Since there is no leakage E.1+E.2=E.1.

**E.4. Estimated baseline emissions:****Table E.4-1. Baseline GHG emissions, tCO<sub>2</sub>e**

Parameter	2008	2009	2010	2011	2012	2008-2012
<b>GHG emissions, total</b>	<b>350 420</b>	<b>326 783</b>	<b>403 703</b>	<b>422 657</b>	<b>440 754</b>	<b>1 944 317</b>
CO <sub>2</sub> from combustion, total	258 195	226 229	283 300	283 300	283 300	1 334 323
CO <sub>2</sub> from heavy fuel oil combustion	140 384	123 004	161 252	161 252	161 252	747 145
CO <sub>2</sub> from coal combustion	117 811	103 226	122 047	122 047	122 047	587 178
CH <sub>4</sub> from decomposition of BWW*	92 225	100 554	120 404	139 357	157 455	609 994
CH <sub>4</sub> from decomposition of bark	60 602	66 306	76 110	85 472	94 411	382 901
CH <sub>4</sub> from decomposition of sawdust and chip screenings	31 623	34 248	44 293	53 885	63 044	227 093

\* Detailed results of calculations of prevented methane emissions see in Annexes 2-1, 2-2.

**E.5. Difference between E.4. and E.3. representing the emission reductions of the project:****Table E.5-1. GHG emission reductions, tCO<sub>2</sub>e**

Parameter	2008	2009	2010	2011	2012	2008-2012
<b>GHG emission reductions, total</b>	<b>227 537</b>	<b>198 292</b>	<b>271 037</b>	<b>289 990</b>	<b>308 088</b>	<b>1 294 943</b>
CO <sub>2</sub> from combustion, total	137 538	99 369	153 977	153 977	153 977	698 838
CO <sub>2</sub> from heavy fuel oil combustion	98 508	78 552	103 057	103 057	103 057	486 232
CO <sub>2</sub> from coal combustion	39 030	20 817	50 920	50 920	50 920	212 606
CH <sub>4</sub> from decomposition of BWW	92 225	100 554	120 404	139 357	157 455	609 994
CH <sub>4</sub> from decomposition of bark	60 602	66 306	76 110	85 472	94 411	382 901
CH <sub>4</sub> from decomposition of sawdust and chip screenings	31 623	34 248	44 293	53 885	63 044	227 093
NO <sub>2</sub> and CH <sub>4</sub> from combustion of additional BWW, total	-2 226	-1 632	-3 344	-3 344	-3 344	-13 889
NO <sub>2</sub> and CH <sub>4</sub> from bark combustion	-1 492	-984	-1 492	-1 492	-1 492	-6 954
NO <sub>2</sub> and CH <sub>4</sub> from combustion of additional sawdust and chip screenings	-734	-647	-1 851	-1 851	-1 851	-6 935

**E.6. Table providing values obtained when applying formulae above:**

Year	Estimated project emissions (tonnes of CO <sub>2</sub> equivalent)	Estimated leakage (tonnes of CO <sub>2</sub> equivalent)	Estimated baseline emissions (tonnes of CO <sub>2</sub> equivalent)	Estimated emission reductions (tonnes of CO <sub>2</sub> equivalent)
2008	122 883	0	350 420	227 537
2009	128 492	0	326 783	198 292
2010	132 666	0	403 703	271 037
2011	132 666	0	422 657	289 990
2012	132 666	0	440 754	308 088
Total (tonnes of CO <sub>2</sub> equivalent)	649 374	0	1 944 317	1 294 943

**SECTION F. Environmental impacts****F.1. Documentation on the analysis of the environmental impacts of the project, including transboundary impacts, in accordance with procedures as determined by the host Party:**

Replacement of KM boiler No.5 envisages replacement of the heavy fuel oil boiler by a fluidized bed boiler for BWB combustion. The project implementation will allow to fire bark as well as to increase the volumes of sawdust and chip screenings combustion, thereby reducing wastes dumping and fossil fuel consumption (coal and heavy fuel oil). The research held within the framework of the project development [R13], [R14], regular checks of efficiency of the gas treatment devices as well as annual reporting data of the Environment Protection Service of the Mill indicate that on the whole the project implementation leads to mitigation of the Mill's environmental impact.

***Sanitary protection zone***

Sanitary protection zone of Solombala PPM is designated within the radius of 1000 m from the enterprise's boundaries. The nearest residential area from the Mill - Pervye Pyatiletki micro district - is located out of the boundaries of the sanitary projection zone.

CHPP-1 where the project is implemented is a part of Solombala PPM and does not have a sanitary protection zone of its own.

***Emissions into the atmosphere***

Most of pollutant emissions from the Mill are fly ash, nonorganic dust, sulphur dioxide, nitrogen dioxide and carbon monoxide.

Before the replacement of boiler No.5 flue gases containing pollutants were emitted without prior treatment into the atmosphere.

According to the original project, ash collecting equipment for "wet" treatment of flue gases from fly ash produced in the course of BWB combustion was installed – this emulsifier had a design particle collection efficiency of 99%. This was the first time when such gas treatment equipment was applied for this type of boilers running on bark and wood wastes.

In the process of operation of the replaced boiler No.5 it was identified that when the load rose above 65 tonnes per hour droplets were carried from the emulsifier, wet ash stuck to the blades of the induced draft fan which resulted in unscheduled shutdowns of the boiler for cleaning up. In order to avoid droplet entrainment and to raise the steam output of the boiler to the planned level of 90 tonnes per hour it was decided to retrofit the gas treatment equipment of boiler No.5. The modernisation of the wet gas treatment system of boiler No.5 consisted of switching on multicyclone of BCU 200/176 type in parallel with the operating emulsifier.

However, despite the modernisation of the gas treatment unit, further operation of boiler No.5 showed that the standard level of fly ash emissions from BWB combustion was nonetheless exceeded. Besides a number of factors that hindered normal operation of the emulsifier and boiler were identified.

As a radical solution it was suggested to have one more modernisation of the gas treatment equipment which envisaged complete replacement of the emulsifiers and multicyclone with a one-stage electrostatic precipitator of EGU 105-21-12-9WS640-400-1 type. The electrostatic precipitator ensures reduction in particle content in the flue gases down to 100 mg/Nm<sup>3</sup>. The electrostatic precipitator design includes a unique system of pneumatic shaking of corona-forming electrodes. The electrostatic precipitator was put into operation on December 29, 2007.

Increase in BWB utilisation level, reduction in coal and heavy fuel oil combustion and modernisation of the flue gas treatment system at boiler No.5 of CHPP-1 allowed to reduce the gross quantity of pollutant emissions. Table F.1-1 shows the pattern of pollutant emissions into the atmosphere from combustion of fuel (for heat and power production) at SPPM according to the reporting statistic forms 2-tp (air). As it

is seen, pollutant emissions from fuel combustion after implementation of the project reduced by over 50%.

**Table F.1-1. Pattern of pollutant emissions to the atmosphere from fuel combustion (for heat and power production) at SPPM, t/year**

Year	Solid particles	Sulphur dioxide	Carbon oxide	Nitrogen oxides (calculated as NO <sub>2</sub> )	Hydrocarbons with allowance for VOC* (excl.methane)	Total
2000	5 526.345	3 518.650	1 589.523	418.049	0.008	11 052.580
2001	6 277.785	4 289.296	2 954.159	683.308	0.001	14 204.550
2002	4 729.071	3 373.127	1 070.332	820.153	0.007	9 992.690
2003	4 482.305	1 286.315	1 686.875	672.963	0.007	8 128.465
2004	3 729.782	3 87.447	2 198.468	692.191	0.003	7 007.891
2005	3 361.488	8 15.914	1 492.308	615.476	0.002	6 285.188
2006	3 256.958	4 62.724	1 261.954	696.271	0.001	5 677.908
2007	1 994.532	7 68.994	1 901.566	592.114	0.001	5 257.207
2008	1 838.410	1 256.454	1 465.569	611.182	0.016	5 171.631
2009	2 355.485	1 899.644	1 333.855	445.381	0.001	6 034.366

\* volatile organic compounds

### Water

At CHPP-1 of Solombala PPM water is used to make up for steam and condensate losses, for cooling of bearings and gland seals of the equipment and for auxiliary needs of chemical water treatment and hydraulic ash handling system. The replacement of the boiler will not increase the CHPP-1's makeup water demand nor will it increase water consumption for auxiliary needs of chemical water treatment.

Water consumption for cooling of bearings amounts to 3.0 m<sup>3</sup>/h. The estimated water consumption for wet ash collector (emulsifier) should amount to 60 m<sup>3</sup>/h. However after installation of the electrostatic precipitator water consumption for removal of dust captured by the electrostatic precipitator should not exceed 10 m<sup>3</sup>/h.

Switching of boiler No.5 to BWB combustion is expected to significantly reduce coal consumption, which means that the consumption of process water for sluicing of ash and slag to the ash disposal site will reduce as well. On the other hand, replacement brings about additional quantities of ash from BWB combustion and additional effluents flow to the hydraulic ash handling system.

Table F.1-2 below shows water consumption before and after replacement of boiler No.5 based on the data [R13] with adjustment for the electrostatic precipitator [R14].

**Table F.1-2. Water consumption in hydraulic ash handling system of CHPP-1, SPPM, thousand m<sup>3</sup>/year**

Purpose	Before replacement of boiler No.5	After replacement of boiler No.5	Change
Process water for hydraulic ash handling system, of which:			
For coal ash	2190	1514	-676
For BWB ash from boiler No.5	-	257	+257



### Wastes

Replacement of boiler No.5 allows additional combustion of around 260 thousand dense m<sup>3</sup> of BWW (on average in 2008-2012) which without the project would have been disposed to the dumps by timber mills of Solombala-Maimaksa Industrial Hub of Arkhangelsk.

Substitution of a part of coal with bark and wood wastes reduces sluicing of ash and slag sludge to the ash disposal site. At the same time the disposal of ash from BWW combustion will increase.

The changes in the quantity of ash and slag residues disposed in the ash disposal site after replacement of boiler No.5 at CHPP-1 in accordance with [R13] are given in Table F.1-3 below.

**Table F.1-3. Changes in the quantity of ash and slag generated at SPPM, t/year**

Parameter	Before replacement of boiler No.5	After replacement of boiler No.5	Change
Ash and slag from combustion of coal	29 324	16 835	-12 489
Ash and slag from combustion of BWW	-	7 675	+7 675
Total	29 324	24 510	-4 814

### Environmental monitoring

Control of environmental pollution will continue to be carried out in accordance with the schedule approved by the Head of the Environment Protection Service and agreed with the supervisory agencies.

### Environmental impact of the project

The most significant implication of the project implementation is the improvement of environment in Arkhangelsk due to reduction of pollutant emissions into the atmosphere.

The pollution dispersion calculation showed that replacement of boiler No.5 of CHPP-1 will not impair the condition of atmosphere in the residential area of the micro district located near the Mill's site.

The project measures allow to enhance environmental safety of the operating CHPP-1 and at the same time to reduce energy resources consumption, decrease pollutant emissions into the atmosphere, effluents discharge into water bodies and solid wastes disposal at ash dumps.

No less important is the reduction of fossil fuel (coal and heavy fuel oil) consumption and corresponding reduction in GHG emissions into the atmosphere, which will contribute to Russia's fulfilment of its commitments to enhance energy efficiency and cut down on GHG emissions. The GHG emission reduction units as a result of the project will total about 260 thousand tonnes of CO<sub>2</sub> per year.

**F.2. If environmental impacts are considered significant by the project participants or the host Party, please provide conclusions and all references to supporting documentation of an environmental impact assessment undertaken in accordance with the procedures as required by the host Party:**

The project complies with the environmental requirements set out by the Russian Federation and does not have significant impact upon the environment which is confirmed by positive opinions of the state environmental expert reviews:

- Opinion of the state expert environmental review commission on the project "Replacement of KM-75-40 boiler No. 5 of CHPP-1 and fitting it with a fluidized bed furnace extension and replacement of ash collecting equipment at OJSC "Solombala PPM". The Department of Natural Resources and Environment Protection in the Arkhangelsk Region, No. 272 of 14.04.2003.
- Opinion of the state expert environmental review commission on design documents for the facility designed for bark and wood waste handling, preparation and feeding for combustion to CHPP-1 and modernisation of gas treatment equipment of KM-75-40 boiler No.5 of OJSC





“Solombala PPM”. The Department of Natural Resources and Environment Protection in the Arkhangelsk Region, No. 400 of 17.05.2004

- Opinion of the state expert environmental review commission on environmental justification of environmental action “Replacement of gas treatment unit of boiler No.5 by one-stage electrostatic precipitator of EGU 105-21-12-9WS640-400-1 type at CHPP-1 of OJSC “Solombala PPM”. Technological and Environmental Inspection Agency in the Arkhangelsk Region, No. 835 of 20.10.2006.

Moreover, the project reduces pollutant emissions into the atmosphere, solid wastes stockpiling at dumps, fossil fuel consumption and GHG emissions.

**SECTION G. Stakeholders' comments****G.1. Information on stakeholders' comments on the project, as appropriate:**

The comments on the project were received mainly from the local and federal agencies in the form of positive opinions of state expert reviews of the project activity and in the form of permits for the project implementation (See, for example, the above list of opinions of the state expert environmental review commission). These documents demonstrate that the project complies with the requirements of the technical regulations, and with the industrial safety, environmental and sanitary requirements.

Besides, a letter from the State Committee for Environment Protection in the Arkhangelsk Region No. 04-08/731 of 11.08.2000 was received prior to commencement of the project. This letter contains positive environmental evaluation of the project and mentions the effect of GHG emission reduction.

Public hearings were not held as this was not required within the framework of this project.

The project measures were covered in the corporate newspaper "Golos Rabohego". Only positive reviews and comments were received from the Mill's employees.

Annex 1**CONTACT INFORMATION ON PROJECT PARTICIPANTS**

Organisation:	Open Joint Stock Company "Solombala Pulp and Paper Mill (OJSC "Solombala PPM")
Street/P.O.Box:	Kirovskaya str.
Building:	4
City:	Arkhangelsk
State/Region:	Arkhangelsk Region
Postal code:	163059
Country:	Russia
Phone:	+ 7 8182 67 91 22
Fax:	+ 7 8182 23 04 94
E-mail:	
URL:	<a href="http://www.solombala.com">http://www.solombala.com</a>
Represented by:	
Title:	
Salutation:	Mrs.
Last name:	Drobeshkina
Middle name:	
First name:	Tatyana
Department:	
Phone (direct):	+ 7 8182 67 91 22
Fax (direct):	+ 7 8182 23 04 94
Mobile:	+ 7 921 720 97 83
Personal e-mail:	tatyana.drobeshkina@sppm.ru



## Annex 2

**BASELINE INFORMATION****Annex 2-1. Calculation of prevented methane emissions from anaerobic decomposition of bark at dumps**

Calculation of CO <sub>2</sub> -equivalent emission reduction from BWW prevented from stockpiling or taken from stockpiles								
<b>General input data</b>								
Conversion factor organic carbon to biogas (a)	1,87	m <sup>3</sup> biogas/kg carbon						
GWP CH <sub>4</sub>	21							
Density methane	0,716	kg/m <sup>3</sup>						
Methane concentration biogas	50%							
Half-life biomass (tau)	15	year						
Decomposition constant (k)	0,046	year <sup>-1</sup>						
Generation factor (zeta)	0,77							
Methane oxidation factor	0,10							
Percentage of the stockpile under aerobic conditions	10%							
BWW - bark wood waste								
<b>LEGEND</b>								
db = dry basis								
wb = wet basis								
yellow cells = unprotected cells								
red marks = comment field included								
<b>Biomass specific input data</b>			<b>Biomass from stockpile</b>	<b>Fresh</b>				
Organic carbon content (db)			53,6%	db				
Moisture content			50,0%	wb				
Organic carbon content (wb)		0,0%	26,8%	wb				
Lignin fraction of C			0,25					
<b>Year</b>	<b>Fresh biomass prevented from stockpiling or taken from stockpile</b>			<b>2008</b>	<b>2009</b>	<b>2010</b>	<b>2011</b>	<b>2012</b>
	<b>Biomass from stockpile (ton<sub>w</sub>)</b>	<b>Age of biomass (years)</b>	<b>Fresh (ton<sub>w</sub>)</b>					
2003			98 220	6 349	6 062	5 789	5 527	5 278
2004			115 908	7 847	7 492	7 154	6 831	6 522
2005			143 806	10 196	9 735	9 296	8 876	8 475
2006			156 241	11 601	11 077	10 577	10 100	9 643
2007			151 873	11 810	11 277	10 768	10 282	9 817
2008			157 148	12 798	12 221	11 669	11 142	10 639
2009			103 647		8 441	8 060	7 696	7 349
2010			157 148			12 798	12 221	11 669
2011			157 148				12 798	12 221
2012			157 148					12 798
<b>Total</b>	<b>0</b>		<b>1 398 287</b>	<b>60 602</b>	<b>66 306</b>	<b>76 110</b>	<b>85 472</b>	<b>94 411</b>
<b>Total emission prevention</b>				<b>60 602</b>	<b>66 306</b>	<b>76 110</b>	<b>85 472</b>	<b>94 411</b>

Spreadsheet model developed by:

BTG biomass technology group B.V.  
P.O. Box 217  
7500 AE Enschede  
The Netherlands  
tel: +31 53 4892897  
fax: +31 53 4893116  
email: office@btgworld.com  
www.btgworld.com

This spreadsheet model is based on the report: "Methane and Nitrous Oxide Emissions from Biomass Waste Stockpiles", Worldbank PCF plus research, August 2002



## Annex 2-2. Calculation of prevented methane emissions from anaerobic decomposition of sawdust and chip screenings at dumps

### Calculation of CO<sub>2</sub>-equivalent emission reduction from BWW prevented from stockpiling or taken from stockpiles

General input data	
Conversion factor organic carbon to biogas (a)	1,87 m <sup>3</sup> biogas/kg carbon
GWP CH <sub>4</sub>	21
Density methane	0,716 kg/m <sup>3</sup>
Methane concentration biogas	50%
Half-life biomass (tau)	15 year
Decomposition constant (k)	0,046 year <sup>-1</sup>
Generation factor (zeta)	0,77
Methane oxidation factor	0,10
Percentage of the stockpile under aerobic conditions	10%

BWW - bark wood waste

#### LEGEND

db = dry basis  
wb = wet basis  
yellow cells = unprotected cells  
red marks = comment field included

Biomass specific input data	Biomass from stockpile	Fresh
Organic carbon content (db)		53,6% db
Moisture content		50,0% wb
Organic carbon content (wb)	0,0%	26,8% wb
Lignin fraction of C		0,25

Year	Fresh biomass prevented from stockpiling or taken from stockpile			2008	2009	2010	2011	2012
	Biomass from stockpile (ton <sub>w</sub> )	Age of biomass (years)	Fresh (ton <sub>w</sub> )					
2003			78 799	5 094	4 864	4 644	4 434	4 234
2004			100 193	6 783	6 477	6 184	5 905	5 638
2005			74 685	5 295	5 056	4 828	4 610	4 401
2006			84 371	6 265	5 982	5 712	5 454	5 208
2007			46 187	3 592	3 429	3 275	3 127	2 986
2008			56 423	4 595	4 388	4 190	4 000	3 820
2009			49 759		4 053	3 870	3 695	3 528
2010			142 335			11 592	11 069	10 569
2011			142 335				11 592	11 069
2012			142 335					11 592
<b>Total</b>	<b>0</b>		<b>917 422</b>	<b>31 623</b>	<b>34 248</b>	<b>44 293</b>	<b>53 885</b>	<b>63 044</b>
<b>Total emission prevention</b>				<b>31 623</b>	<b>34 248</b>	<b>44 293</b>	<b>53 885</b>	<b>63 044</b>

Spreadsheet model developed by:

BTG biomass technology group B.V.  
P.O. Box 217  
7500 AE Enschede  
The Netherlands  
tel: +31 53 4892897  
fax: +31 53 4893116  
email: office@btgworld.com  
www.btgworld.com

This spreadsheet model is based on the report: "Methane and Nitrous Oxide Emissions from Biomass Waste Stockpiles", Worldbank PCF *plus* research, August 2002



## Annex 2-3. Calculation of cash flows of the investment project for the two implementation options

## Input data

Parameter	Unit	Value
Dollar exchange rate	RUR/USD	28,00
Discount	%	20
Profit tax	%	35
Property tax	%	1,8
Service life	years	20
Price of heavy fuel oil	RUR/t	2000
Price of coal	RUR/t	350
Price of purchased BWW	RUR/dence m3	75
Price of early emission reductions	USD/tCO2e.	3,0
Price of ERU	USD/tCO2e.	10,0
Total savings of heavy fuel oil	t e.f./year	36 560
Fuel oil in overall consumpt. of fuel oil & coal	-	0,60

## Reduction (increase) in fuel consumption

Parameter	Unit	2001	2002	2003	2004	2005	2006	2007	2008	2009	2010	2011	2012	2013	2014	2015	2016	2017	2018	2019	2020
Reduction in heavy fuel oil consumption	t		8 006	16 012	16 012	16 012	16 012	16 012	16 012	16 012	16 012	16 012	16 012	16 012	16 012	16 012	16 012	16 012	16 012	16 012	16 012
Reduction in coal consumption	t		13 796	27 592	27 592	27 592	27 592	27 592	27 592	27 592	27 592	27 592	27 592	27 592	27 592	27 592	27 592	27 592	27 592	27 592	27 592
Increase in consumption of purchased BWW	dence m3		60 000	120 000	120 000	120 000	120 000	120 000	120 000	120 000	120 000	120 000	120 000	120 000	120 000	120 000	120 000	120 000	120 000	120 000	120 000

## Total income from the project implementation

Parameter	Unit	2001	2002	2003	2004	2005	2006	2007	2008	2009	2010	2011	2012	2013	2014	2015	2016	2017	2018	2019	2020
Reduction in heavy fuel purchase costs	thousand USD		572	1 144	1 144	1 144	1 144	1 144	1 144	1 144	1 144	1 144	1 144	1 144	1 144	1 144	1 144	1 144	1 144	1 144	1 144
Reduction in coal purchase costs	thousand USD		172	345	345	345	345	345	345	345	345	345	345	345	345	345	345	345	345	345	345
Increase in BWW purchase costs	thousand USD		161	321	321	321	321	321	321	321	321	321	321	321	321	321	321	321	321	321	321
Total reduction of costs	thousand USD		584	1 167	1 167	1 167	1 167	1 167	1 167	1 167	1 167	1 167	1 167	1 167	1 167	1 167	1 167	1 167	1 167	1 167	1 167

## Capival investments

Parameter	Unit	2001
Capital expenditure	thousand USD	-4 596

## Depreciation

Parameter	Unit	2001	2002	2003	2004	2005	2006	2007	2008	2009	2010	2011	2012	2013	2014	2015	2016	2017	2018	2019	2020
Depreciation charges	thousand USD	0,00	-114,90	-229,80	-229,80	-229,80	-229,80	-229,80	-229,80	-229,80	-229,80	-229,80	-229,80	-229,80	-229,80	-229,80	-229,80	-229,80	-229,80	-229,80	-229,80
Fixed assets value	thousand USD	4 596,00	4 481,10	4 251,30	4 021,50	3 791,70	3 561,90	3 332,10	3 102,30	2 872,50	2 642,70	2 412,90	2 183,10	1 953,30	1 723,50	1 493,70	1 263,90	1 034,10	804,30	574,50	344,70

## Taxes

Parameter	Unit	2001	2002	2003	2004	2005	2006	2007	2008	2009	2010	2011	2012	2013	2014	2015	2016	2017	2018	2019	2020
Property tax	thousand USD		-81,69	-78,59	-74,46	-70,32	-66,18	-62,05	-57,91	-53,77	-49,64	-45,50	-41,36	-37,23	-33,09	-28,95	-24,82	-20,68	-16,55	-12,41	-8,27
Profit tax	thousand USD		-135,45	-300,57	-302,02	-303,47	-304,92	-306,36	-307,81	-309,26	-310,71	-312,15	-313,60	-315,05	-316,50	-317,94	-319,39	-320,84	-322,29	-323,74	-325,18

## Economic parameters without sale of ERUs

Parameter	Unit	2001	2002	2003	2004	2005	2006	2007	2008	2009	2010	2011	2012	2013	2014	2015	2016	2017	2018	2019	2020
Net cash flow	thousand USD	-4 596	366	788	791	793	796	799	801	804	807	810	812	815	818	820	823	826	828	831	1 178
Accumulated cash flow	thousand USD	-4 596	-4 230	-3 442	-2 651	-1 857	-1 061	-263	539	1 343	2 150	2 959	3 771	4 586	5 404	6 224	7 047	7 873	8 701	9 532	10 711

NPV	thousand USD	-1 073
IRR	%	15,07%

## Economic parameters with sale of ERUs

Parameter	Unit	2001	2002	2003	2004	2005	2006	2007	2008	2009	2010	2011	2012	2013	2014	2015	2016	2017	2018	2019	2020
Amount of ERUs	tCO2e		45 810	91 621	91 621	91 621	91 621	91 621	91 621	91 621	91 621	91 621	91 621	91 621	91 621	91 621	91 621	91 621	91 621	91 621	91 621
Revenues from sale of ERUs	thousand USD		137	275	275	275	275	275	916	916	916	916	916								
Net cash flow	thousand USD	-4 596	504	1 063	1 066	1 068	1 071	1 074	1 718	1 720	1 723	1 726	1 728	815	818	820	823	826	828	831	1 178
Accumulated cash flow	thousand USD	-4 596	-4 092	-3 029	-1 964	-895	175	1 249	2 967	4 687	6 410	8 136	9 864	10 679	11 497	12 317	13 140	13 966	14 794	15 625	16 803

NPV	thousand USD	644
IRR	%	22,73%



Annex 3

**MONITORING PLAN**

See Section D

Annex 4**REFERENCES**

- [R1] Guidance on criteria for baseline setting and monitoring, Version 02, JISC  
([http://ji.unfccc.int/Ref/Documents/Baseline\\_setting\\_and\\_monitoring.pdf](http://ji.unfccc.int/Ref/Documents/Baseline_setting_and_monitoring.pdf))
- [R2] Methane and Nitrous Oxide Emissions from Biomass Waste Stockpiles, PCFplus Research, World Bank, August 2002
- [R3] Operational Guidelines for Project Design Documents of Joint Implementation Projects. Volume 1. General Guidelines. Version 2.3. Ministry of Economic Affairs of the Netherlands. May 2004  
(<http://ji.unfccc.int/CritBasMon/CallForInputs/BaselineSettingMonitoring/ERUPT/index.html>)
- [R4] S.I.Golovkov, I.F. Koperin, V.I.Naidenov. Use of wood wastes in energy production. – M.: Forestry, 1987
- [R5] 2006 IPCC Guidelines for National Greenhouse Gas Inventories. Volume 2, Energy.  
(<http://www.ipcc-nggip.iges.or.jp/public/2006gl/vol2.htm>)
- [R6] Methodological tool to determine the baseline efficiency of thermal or electric energy generation systems. Version 01. CDM Executive Board  
(<http://cdm.unfccc.int/methodologies/PAMethodologies/tools/am-tool-09-v1.pdf>)
- [R7] K.F.Roddatis. Boiler Units. – M.: Energy, 1977
- [R8] Minutes of the technical meeting on reconstruction of boiler unit No.4 (5) of CHPP-1 and switching it to wood wastes, 03 March 2000, Arkhangelsk
- [R9] Contract No. 44-00 of 10 December 2000 “Reconstruction with installation of fluidized bed furnace extension and replacement of ash-collecting equipment of KM-75-40 boiler No.5 of CHPP-1” executed between OJSC “Solombala PPM” and CJSC “AMU Sevzapenergomontazh”
- [R10] OJSC “Solombala PPM”, CHPP-1. Reconstruction with installation of fluidized bed furnace extension and replacement of ash-collecting equipment of KM-75-40 boiler No.5. Detailed design. Volume 1. Executive summary. LLC “INEKO”, Moscow, 2002.
- [R11] OJSC “Solombala PPM”. Facility for BWB handling, preparation and feeding for combustion to CHPP-1. Principal technical solutions. CJSC “Arkhgiprobum”. Arkhangelsk, 2001.
- [R12] OJSC “Solombala PPM”. Installation of electrostatic precipitator on KM-75-40 boiler No.5 of CHPP-1. Volume 1. Executive summary. LLC “INEKO”, Moscow, 2006.
- [R13] OJSC “Solombala PPM”, CHPP-1. Reconstruction with installation of fluidized bed furnace extension and replacement of ash-collecting equipment of KM-75-40 boiler No.5. Detailed design. Volume 4. Environmental Protection. CJSC “Arkhgiprobum”. Arkhangelsk, 2002.
- [R14] OJSC “Solombala PPM”, CHPP-1. Replacement of gas treatment unit of boiler No.5 with a one-stage electrostatic precipitator of EGU 105-21-12-9WS640-400-2 type. Ecological justification of environmental measure. LLC “Scientific Research Center “Viking”, Arkhangelsk, 2006.
- [R15] The prospects of implementation of the mechanisms provided for by the Kyoto Protocol to UNFCCC in the Arkhangelsk Region. ANO “Environmental Investments Center”, Arkhangelsk, 2001.
- [R16] Acceptance Certificate for commissioning of replaced KM-75-40 boiler No.5 of CHPP-1, OJSC “Solombala PPM” dated 30 June 2003.
- [R17] Acceptance Certificate for commissioning of the facility for BWB handling, preparation and





feeding for combustion to CHPP-1 dated 30 September 2004.

- [R18] Acceptance Certificate for commissioning of the electrostatic precipitator of EGU 105-21-12-9WS640-400-2 type (for boiler No.5) dated 29 December 2007.
- [R19] World Resources Institute (WRI) and World Business Council for Sustainable Development. 2001. Mobile Combustion CO<sub>2</sub> Emissions Calculation. Guidelines to calculation. Washington D.C.: World Resources Institute
- [R20] GOST 3619-89 "Steam plant boilers. Types and main parameters" (approved by resolution of USSR Gosstandard of 23 March 1989, No.630)
- [R21] Thermal design of boiler units (Normative method). Publishing House NPO CKTI, St.-Pet., 1998.

- - - - -