



JOINT IMPLEMENTATION PROJECT DESIGN DOCUMENT FORM
Version 01 - in effect as of: 15 June 2006

CONTENTS

- A. General description of the project
- B. Baseline
- C. Duration of the project / crediting period
- D. Monitoring plan
- E. Estimation of greenhouse gas emission reductions
- F. Environmental impacts
- G. Stakeholders' comments

Annexes

- Annex 1: Contact information on project participants
- Annex 2: Baseline information
- Annex 3: Monitoring plan

**SECTION A. General description of the project****A.1. Title of the project:**

Title of the project: **“Waste Heap Dismantling in the Rebrykove Town of Luhansk Region of Ukraine with the Aim of Reducing Greenhouse Gases Emissions into the Atmosphere”**

Version of the PDD: v 2.0

Date of the document: 20/07/2012

Sectoral scope(s): 8: Mining/mineral production

A.2. Description of the project:

The proposed project is a progressive project that envisages processing and dismantling of the waste heaps, which are located in the Luhansk Region of Ukraine.

This Project is aimed at coal extraction from the mine's waste heaps of the Luhansk Region of Ukraine. These waste heaps have been accumulated some time before the start of the project activity from the mining waste of underground mines. Project activity will prevent greenhouse gas emissions into the atmosphere during combustion of the heaps and will contribute an additional amount of coal, without the need for mining. The Project activities include installation of the equipment for coal extraction and beneficiation near the processing waste heaps and applying special machinery that will perform preparation, loading and transportation of the rock from the waste heaps to the beneficiation factory. After purifying of the matter, the extracted coal will be sold for heat and power generation and the remaining bare rock will be utilized for land engineering and road building.

Situation existing prior to the project implementation

The common practice of coal mining in Ukraine is application of underground method. The Ukrainian coal mining industry is a complex business system that integrates around 167 active coal mines and 3 coal strip mines, mines at the decommissioning stage, coal beneficiation, transportation and other enterprises. Ukraine is the largest coal mining region in Europe and is among top eight in the world. The main coal mining area is Donbas that is located in Donetsk and Luhansk regions for the most part.

Coal is found in the area of Donbas at the average depth of 400-800 m. The average thickness of coal-bed is 0.6-1.2 m. Therefore coal in Donbas is produced mostly by mining. Most mines operate on the depth of 400-800 m but there are 35 mines in Donbas that extract coal from the 1000-1300 m level. Coal-beds in Donetsk basin are interleaved with rock and are usually found every 20-40 m. Mining activities in such conditions result in vast amounts of matter being extracted and brought to the surface. Coal is separated from rock and this non-coal matter forms huge waste heaps of tailings found almost everywhere in Donbas. Separation process on the mines was not and sometimes is not entirely efficient. For a long period of time it was not economically feasible to extract 100% of coal from the rock that had been mined. That is why waste heaps of Donbas contain considerable masses of coal. In the course of time those waste heaps are vulnerable to spontaneous ignition and slow combustion. According to different estimates the rock that is mined contains only up to 65-70% of coal only, the rest is barren rock. Up to 60% of this rock is put into waste heaps. According to specialists' research, percentage of combustible material in waste heaps is 15-30%, meanwhile there can be from 7% to 28-32% of coal¹.

¹Geology of Coal Fires: Case Studies from Around the World, Glenn B. Stracher, Geological Society of America, 2007, p. 47



Waste heaps that are burning or are close to spontaneous ignition are sources of uncontrolled greenhouse gas and hazardous substances emissions. The latter include sulphurous anhydride that transforms into sulphur acid and is the reason for acid rains, hydrogen sulphide and carbon oxide. Ground water is contaminated with solid particles, becomes hard and acid when it contacts a waste heap. Erosion processes that often destroy the integrity of the waste heaps are responsible for contamination of nearby areas with particles that contain hazardous materials (like sulphur). Erosion can lead overtime to the total destruction of a waste heap in a massive landslide that is dangerous both in terms of direct hazard to population and property and massive emissions of particles and hazardous substances into the atmosphere. Erosion also helps to intensify the process of spontaneous combustion. Combustion of coal in the waste heap is rather long-term and lasts from 5 to 7 years. The waste heaps also take up large space areas. As of 2007 the waste heaps in Donbas occupied more than 10 ths hectares of land. And this figure keeps growing.

Despite the dangers caused by the burning waste heaps, it is common in the area of Donbas to not extinguish the fires immediately. The owners that are responsible for the waste heaps receive relatively small fines for the air pollution, therefore there is little incentive for them to deal with the problem, and extinguishing those heaps that are currently alight can be postponed indefinitely.

In the baseline scenario it is assumed that this common practice will continue and waste heaps will be burning and emitting GHG into the atmosphere until the coal is consumed. Whereas using improved extraction techniques, proposed in this project, the residual coal can be extracted from the waste heaps and the coal can be used to for the energy needs of local consumers. The reclaimed coal will replace coal that would have otherwise been mined, causing fugitive emissions of methane during the mining process.

Thus, **the baseline scenario** is the continuation of the current situation, which is the continuation of the situation before the project was installed, without beneficiation plant and waste heap dismantling.

The project activity will prevent greenhouse gas emissions into the atmosphere during combustion of the heaps and will contribute an additional amount of coal, without the need for mining. The Project includes the installation of coal extraction units and the grading of the extracted coal. Extracted coal is then sold for heat and power production.

Therefore, **in the project scenario** the coal extracted from the waste heaps will partly substitute the coal from the mine, decreasing fugitive methane emissions, and reduce emissions GHG emissions due to waste heap combustion by extracting all of the combustible material from the waste heaps.

Once the waste heap has been processed and coal is extracted, the land released from under the waste heap is remediated and returned to the community. The residue after processing, which is mainly barren rock, is used to shape terrain of abandoned open-cast mining sites so that such areas may be used again for development purposes. The picture below illustrates the transformation of the terrain with the rock from processed waste heap.

Brief summary of the history of the project: The project has been initiated in the start of 2006. Installation and construction works were initiated by the end of 2007. 05th of December 2008 is the date of commissioning of the beneficiation plant equipment. The operations at the facility have started on the 05th of December 2008. The JI was one of the drivers for the project from the start and financial benefits provided by the JI mechanism were considered as one of the reasons to start the project and are crucial in the decision to start the operations.

**A.3. Project participants:**

<u>Party involved</u> *	Legal entity <u>project participant</u> (as applicable)	Please indicate if the <u>Party involved</u> wishes to be considered as <u>project participant</u> (Yes/No)
Ukraine (Host party)	Limited Liability Company Temp LTD-A	No
The Netherlands	Ohana LLP	No

* Please indicate if the Party involved is a host Party.

Temp LTD-A LLC is the project host.

A.4. Technical description of the project:**A.4.1. Location of the project:**

This project is implemented within Luhansk region of Ukraine where waste heaps processing facility and waste heaps are located:

- waste heaps processing facility "Kyivska" at address: Luhansk region, Anthracite area, Rebrykove village, 26 Objizna Street (near the town of Rovenky, Luhansk region) ;
- Waste heap # 5 of the former mine # 2 "Kyivska" located outside the municipalities in which, according to the State Land Cadastre listed in Rebrikiivskiy village council, Antratsitovskiy district;
- Waste heap # 6 of the former mine # 2 "Kyivska" located outside the municipalities in which, according to the State Land Cadastre listed in Rebrikiivskiy village council, Antratsitovskiy district;
- Waste heap # 1 of the former mine #5 PE "Mine" Krasnokutska "SE "Donbasantratsit " Luhansk region Krasny Luch town ;
- Waste heap # 3 Luhansk region Rovenky town in the land mines Cosmonauts SE "Rovenkyantratsyt" ;
- Waste heap number 9 mine site "Druzhba" of the former coal mine number 44 of Anthracite City;
- Waste heap of the former mine No 15 of the PE "Mine named after 50th anniversary of the Soviet Ukraine" of Luhansk region, Anthracite town near Sadovaya Str.

A.4.1.1. Host Party(ies):

Ukraine

Ukraine is an Eastern European country that ratified the Kyoto Protocol to UN FCCC on February 4th, 2004, enters into the list of the countries of the Annex 1 and is eligible for the Joint Implementation projects.



Fig.1 The map of Ukraine with neighboring countries

A.4.1.2. Region/State/Province etc.:

Luhansk region

A.4.1.3. City/Town/Community etc.:

Antracite, Rovenky, Krasnyi Luch Towns and surrounding districts.

A.4.1.4. Detail of physical location, including information allowing the unique identification of the project (maximum one page):

The physical location of the project is at the

- waste heaps processing facility “Kyivska” at address: Luhansk region, Anthracite area, Rebrykove village, 26 Objizna Street (near the town of Rovenky, Luhansk region) 48°7'16.90"N 39°22'48.36"E²;
- Waste heap # 5 of the former mine # 2 "Kyivska" 48° 7'16.90"N 39°22'48.36"E³ located outside the municipalities in which, according to the State Land Cadastre listed in Rebrykivskiy village council, Anratsitovskiy district;

2

http://toolserver.org/~geohack/geohack.php?language=ru&pagename=%D0%A0%D0%B5%D0%B1%D1%80%D0%B8%D0%BA%D0%BE%D0%B2%D0%BE%D0%B5%E2%84%965¶ms=48.121361_N_39.380100%E2%80%8E%E2%80%8E%E2%80%8E_E_type:city#.D0.A4.D0.BE.D1.82.D0.BE.D0.B3.D1.80.D0.B0.D1.84.D0.B8.D0.B8

3

http://toolserver.org/~geohack/geohack.php?language=ru&pagename=%D0%A0%D0%B5%D0%B1%D1%80%D0%B8%D0%BA%D0%BE%D0%B2%D0%BE%D0%B5%E2%84%966¶ms=48.121361_N_39.380100%E2%80%8E%E2%80%8E%E2%80%8E_E_type:city#.D0.A4.D0.BE.D1.82.D0.BE.D0.B3.D1.80.D0.B0.D1.84.D0.B8.D0.B8



- Waste heap # 6 of the former mine # 2 "Kyivska" 48° 7'16.90"N 39°22'48.36"E located outside the municipalities in which, according to the State Land Cadastre listed in Rebrikiivskiy village council, Anratsitovsky district;
- Waste heap # 1 of the former mine #5 PE "Mine" Krasnokutska "SE "Donbasanratsit " Luhansk region Krasny Luch town 48°12'13"N 38°48'50"E⁴;
- Waste heap # 3 Luhansk region Rovenky town in the land mines Cosmonauts SE "Rovenkyanratsyt" 48°7'14.25"N 39°28'21.54"E⁵;
- Waste heap number 9 mine site "Druzhba" of the former coal mine number 44 of Anthracite City. The geographic coordinates of the site are: 48°7'25"N 39°5'50"E⁶
- Waste heap of the former mine No 15 of the PE "Mine named after 50th anniversary of the Soviet Ukraine" of Luhansk region, Anthracite town near Sadovaya Str. The geographic coordinates of the site are: 48° 6' 43.77", N 39° 2' 12.89" E⁷

4

http://toolserver.org/~geohack/geohack.php?language=ru&pagename=%D0%9A%D1%80%D0%B0%D1%81%D0%BD%D0%BE%D0%BA%D1%83%D1%82%D1%81%D0%BA%D0%BE%D0%B5¶ms=48.203611_N_38.813889%E2%80%8E_E_type:city#.D0.A4.D0.BE.D1.82.D0.BE.D0.B3.D1.80.D0.B0.D1.84.D0.B8.D0.B8

5

http://toolserver.org/~geohack/geohack.php?language=ru&pagename=%D0%A0%D0%BE%D0%B2%D0%B5%D0%BD%D1%8C%D0%BA%D0%B8¶ms=48.120625_N_39.472650%E2%80%8E%E2%80%8E%E2%80%8E%E2%80%8E_E_type:city#.D0.A4.D0.BE.D1.82.D0.BE.D0.B3.D1.80.D0.B0.D1.84.D0.B8.D0.B8

6

http://toolserver.org/~geohack/geohack.php?language=ru&pagename=%D0%90%D0%BD%D1%82%D1%80%D0%B0%D1%86%D0%B8%D1%82¶ms=48.123611_N_39.097222%E2%80%8E_E_type:city#.D0.A4.D0.BE.D1.82.D0.BE.D0.B3.D1.80.D0.B0.D1.84.D0.B8.D0.B8

7

http://toolserver.org/~geohack/geohack.php?language=ru&pagename=%D0%90%D0%BD%D1%82%D1%80%D0%B0%D1%86%D0%B8%D1%82%20%D1%83%D0%BB.%D0%A1%D0%B0%D0%B4%D0%BE%D0%B2%D0%B0%D1%8F¶ms=48.112158_N_39.036914%E2%80%8E_E_type:city#.D0.A4.D0.BE.D1.82.D0.BE.D0.B3.D1.80.D0.B0.D1.84.D0.B8.D0.B8



Fig.2 Map of Ukraine and location of the project site

A.4.2. Technology(ies) to be employed, or measures, operations or actions to be implemented by the project:

The Project envisages high-grade anthracite production for the needs of household energy sector. The main stages of coal extraction and sorting can be found below.

The technology applied in this project is the dense medium coal washing plant. The technological process and equipment used in the project reflect current good engineering practices. The basic technology of coal washing plant has gained wide popularity in the 1990s as the most efficient process for coal washing. Technological process is advanced, does not require vast amounts of materials and workforce, is reliable and productive. The technology used in this project is state-of-the-art technology and is unlikely to be replaced by any other technology during the lifetime of the project as it offers the best quality and efficiency of the coal washing process among other technologies commonly used in Ukraine such as simple vibration screens and spiral separators.

The coal washing by dense medium cyclone is the very efficient separation process. It is ideally suited for difficult coal separation and cleaning high value coal for domestic and industrial use. The overall process differs from the water-based separation plant because the medium is created using magnetite (fine iron particles) instead of the fine particles in the raw material. This allows for more control and a wider range of separation gravities.

The simplified flow diagram on Figure below shows the separation process by dense medium cyclone.

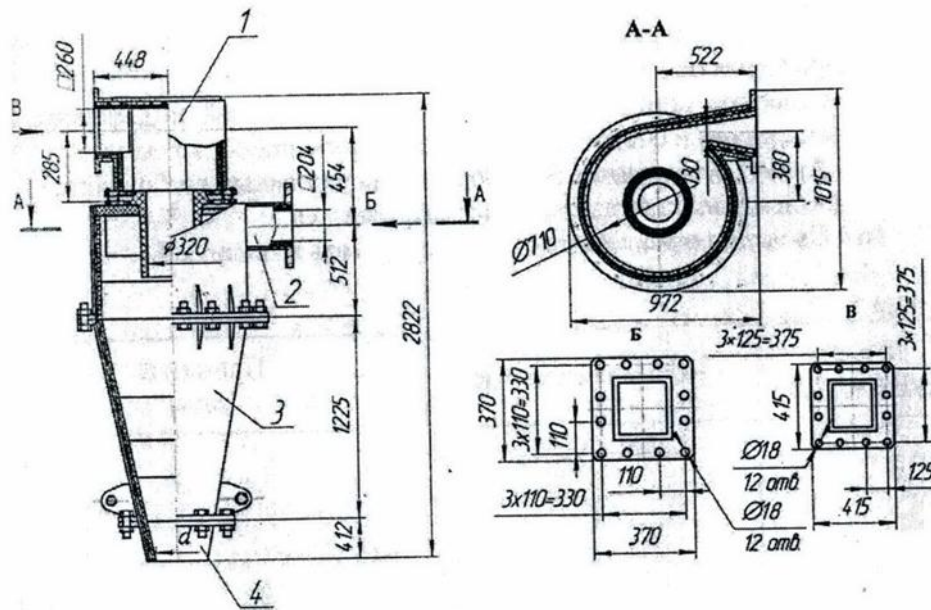

1. Drainage segment
2. Loading segment
3. Conus
4. Spray head

Fig.3 Dense medium cyclone operation⁸



⁸ <http://masters.donntu.edu.ua/2007/fema/svetlichnaya/library/bedran.htm>



Fig.4 Project activity equipment

Dense medium cyclones are used for very accurate separation of particles of different density. Particles that are smaller than 0.5 mm are removed from the mixture before it enters the cyclone. Magnetite is added to the water/particle mixture to allow precise control of density. The dense medium cyclone is mounted at a certain angle. The lighter particles (coal) come out the upper end and the heavier particles (shale) the lower.

In cyclones, the small particles are separated by centrifugal and vortex action (the cyclone itself does not move). The water/particle/magnetite mixture is pumped into the side of the cyclone tangentially (1) and swirls around creating a vortex (2) in which the lighter particles are drawn out through the central vortex tube (5) in the discharge chamber (6). The heavier particles are thrown by centrifugal force to the wall of the cyclone and are discharged at the opposite end (3).

The dense medium cyclone can efficiently separate raw material of a wide range of proportions. Other benefits include: low power requirement, high efficiency, low magnetite consumption, robust modular design, and quick to assemble easy to move design.

For waste heap dismantling the following combined technology is foreseen:

- bulldozer gets to the top of the waste heap along its tail;
- the heap is gradually lowered by moving of the rocks by bulldozer to the edge of the heap in horizontal layers. Heap lowering by bulldozer is performed to a certain height, after which arrival of trucks on the heap is possible. Further dismantling is conducted by dump excavators usage;
 - Near the waste heap rock is moved to storage areas by machines and transported by automobiles.

Waste heap rock processing is performed according to the following technology:

- The rock is fed by motor transport to the drop-off station and rocks sorting bunker;
- Rock mass is graded at vibration screen into grades "0-40 mm" and "+40 mm";
- Rock mass of "40 mm" grade is put by conveyor into a bunker for shipment, in the process of which manual selection of coal takes place;
- "0-40 mm" rock mass is put by conveyor to processing unit;



- wet grading into "0-1 mm" and "1-40 mm" grades takes place at vibration screen;
- "0-1 mm" grade is put by pump on Hydraulic cyclones where then is condensed, after which is fed to the spiral separators where the concentrate is separated from the slurry (rock dust);
- Dehydration of "0-1 mm" concentrate at the HF vibration screen;
- "1-40 mm" grade is divided in dense medium hydrocyclone with recovery of two products - coal concentrate and waste;
- Suspension with concentrate is washed at the vibration screen with "6.1 mm" and "6-40 mm" grades coming out;
- "1-6 mm" grade feeding for shipment;
- "6-40 mm" grade concentrate feeding on vibration screening with the allocation of "6-13 mm" and "13-40 mm" grades;
- "6-13 mm" and "13-40 mm" grades concentrate feeding for shipment;
- Transportation of "1-40 mm" waste to the loading bunker by conveyor;
- Wash off of suspension, waste dehydration on vibration screen and its transportation for shipment;
- Regeneration of suspension at drum magnetic separators in two stages, to obtain magnetite concentrate, draining of turbidity-free and slime water;
- Thickening of sludge in thickeners with flocculation;
- condensed sludge dehydration at HF screening.

The main technical parameters

Designed capacity of enrichment plant - 640 thousand tons / year

Installed capacity - 1,482 kW

Productivity of transportation knots, receiving and sorting of the rock mass - 1024 thousand tons / year

Technical parameters of fuel consumption of machines and equipment:

Name of equipment	Quantity	fuel consumption, l/km or l/1motohour
KRAZ 256-B1	7	0,48
KRAZ 65101	1	0,48
Bulldozer T-130	3	17,0
Truck XZ657	2	17,0
Mobile screen KLEEMANN 15 Z-AD	1	20,0
Truck TOTA XZ 657	1	17,0
Excavator HITACHI ZX330LC-3	1	22,0



Fig.5 KRAZ 65101



Fig.6 Mobile screen KLEEMANN 15 Z-AD



Fig.7 Truck TOTA XZ 657



Most of the equipment utilized by the project such as trucks, excavators, bulldozers is of a standard type used for industrial applications worldwide. The project activity will use a limited number of individually ordered equipment.

The above mentioned confirms that the conception of the project is based on the current modern common practice. The project is not expected replacement project technology to another technology during the period of the project.

The program of training

The project does not require extensive initial training. The required workforce can get basic industrial profession training locally. Most of the required personnel such as heavy machinery operators, trucks and excavator drivers, electric and mechanical maintenance workers are locally available.

The program of maintenance service

Maintenance needs are covered by the local capacities: in-house maintenance workers and outsourced maintenance and repair subcontractors. The project makes provisions for training needs. All workers are required to have a valid professional education certificate and pass periodical safety trainings and exams. Professional education can be obtained locally in the Luhansk region in all of the professional areas covered by the project.

The project has been initiated in the start of 2006. Installation and construction works were initiated by the end of 2007. 05th of December 2008 is the date of commissioning of the beneficiation plant equipment. The operations at the facility have started on the 05th of December 2008. Initial number of waste heaps will be processed by this unit.

<p>A.4.3. Brief explanation of how the anthropogenic emissions of greenhouse gases by sources are to be reduced by the proposed JI project, including why the emission reductions would not occur in the absence of the proposed project, taking into account national and/or sectoral policies and circumstances:</p>

The proposed project is aimed at the extraction of coal from the waste heaps of underground coal mines. Waste heaps are frequently spontaneously igniting and burning, causing emissions of hazardous substances and green-house gases. The fraction of coal in the waste heaps can be as high as 28-32%⁹, so the risk of spontaneous self-heating and burning is very high. If a waste heap has started burning, even if the fire is extinguished, it will continue burning after a while unless the fire is extinguished regularly. Burning waste heaps in Ukraine are very often not taken care of properly, especially when there is no immediate danger to population and property, i.e. if the waste heap is located at a considerable distance from a populated area, or is at the early stages of self-heating. The monitoring of the waste heaps condition is not done on a systematic and timely basis and information is frequently missing. The only way to prevent a waste heap from burning is to extract all the combustible matter, which is generally residual coal from the mining process. This project will reduce the emissions by extracting coal from the waste heap matter and using the remaining rock for land engineering.

Coal extracted from the waste heaps will substitute the coal from the mines and will be used mainly for energy production purposes at coal-fired power plants. Coal mining is a source of the fugitive emissions

⁹ *Geology of Coal Fires: Case Studies from Around the World*, Glenn B. Stracher, Geological Society of America, 2007, p. 47
<http://books.google.com.ua/books?id=eJU0WOABSWIC&printsec=frontcover&hl=ru#v=onepage&q&f=false>

of methane, therefore, the project activity will reduce methane emissions by reducing the amount of coal required to be mined.

Emission reductions due to the implementation of this project will come from three major sources:

- Removing the source of green-house gas emissions from the burning / slow burning waste heap by the extraction of non-combusted coal contained in a waste heap;
- Negative leakage through reduced fugitive emissions of methane due to the replacement of coal that would have been mined, by the coal extracted from the heap under the project activity.
- Reduce electricity consumption at waste heap dismantling in comparison with energy consumption at coal mine.

Waste heaps are sources of uncontrolled green-house gas emissions, hazardous substances emissions, ground water contamination. Addressing problems of waste heaps is costly and is not addressed in a systematic way in Ukraine. Efforts to stop burning of waste heaps and break them down completely are in line with the existing environmental legislation of Ukraine. The proposed project is positively evaluated by local authorities.

Detailed description on the baseline setting and full additionality test can be found in section B of this PDD.

A.4.3.1. Estimated amount of emission reductions over the crediting period:

	Years
Length of the <u>crediting period</u>	4 years and 1 month
Year	Estimate of annual emission reductions in tonnes of CO₂ equivalent
2008	111134
2009	1817039
2010	1597586
2011	1762148
2012	1824782
Total estimated emission reductions over the <u>crediting period</u> (tonnes of CO ₂ equivalent)	7112689
Annual average of estimated emission reductions over the <u>crediting period</u> (tonnes of CO ₂ equivalent)	1741883

Table.1 Estimated amount of CO₂e Emission Reductions over the crediting period

	Years
Length of the <u>crediting period</u>	10
Year	Estimate of annual emission reductions in tonnes of CO₂ equivalent
2013	1824782
2014	1824782
2015	1824782
2016	1824782
2017	1824782
2018	1824782
2019	1824782
2020	1824782



2021	1824782
2022	1824782
Total estimated emission reductions after the <u>crediting period</u> (tonnes of CO ₂ equivalent)	18247820
Annual average of estimated emission reductions after the <u>crediting period</u> (tonnes of CO ₂ equivalent)	1824782

Table.2 Estimated amount of CO₂e Emission Reductions after the crediting period

Thus the estimated amount of emission reductions over the commitment period (2008-2012) is **7112689** tons of CO₂e.

Description of formulae used to estimate emission reductions is represented in section B.

A.5. Project approval by the Parties involved:

The project has been officially presented for endorsement to the Ukrainian authorities. State Environmental Investments Agency of Ukraine has issued a Letter of Endorsement for the project #2025/23/7 dated 27/07/2012.

According to the national Ukrainian procedure, the LoAs by Ukraine is expected after the project determination.

**SECTION B. Baseline****B.1. Description and justification of the baseline chosen:**

In accordance with appendix B to decision 9/CMP.1 of the JI guidelines and following the guidance on criteria for baseline setting and monitoring¹⁰ version 3, the baseline is chosen and described below, using the following step-wise approach.

Step 1 Indication and description of the approach chosen regarding baseline setting

Project participants may select either:

- (a) An approach for baseline setting and monitoring developed in accordance with appendix B of the JI guidelines (JI specific approach); or
- (b) A methodology for baseline setting and monitoring approved by the Executive Board of the clean development mechanism (CDM), including methodologies for small-scale project activities, as appropriate, in accordance with paragraph 4(a) of decision 10/CMP.1, as well as methodologies for afforestation/reforestation project activities.

There is no approved CDM methodology which is applicable – without revisions – to waste heap dismantling. Therefore, a JI specific approach (a) is applied.

JI specific approach

According to the JI guidelines:

- (a) The baseline for a JI project is the scenario that reasonably represents the anthropogenic emissions by sources or anthropogenic removals by sinks of GHGs that would occur in the absence of the proposed project. A baseline shall cover emissions from all gases, sectors and source categories listed in Annex A of the Kyoto Protocol, and anthropogenic removals by sinks, within the project boundary;
- (b) A baseline shall be established:
 - (i) on a project-specific basis and/or using a multi-project emission factor;
 - (ii) in a transparent manner with regard to the choice of approaches, assumptions, methodologies, parameters, data sources and key factors;
 - (iii) taking into account relevant national and/or sectoral policies and circumstances, such as sectoral reform initiatives, local fuel availability, power sector expansion plans, and the economic situation in the project sector;
 - (iv) in such a way that emission reduction units (ERUs) cannot be earned for decreases in activity levels outside the project activity or due to force majeure;
 - (v) taking account of uncertainties and using conservative assumptions;
- (c) Project participants shall justify their choice of baseline.

To calculate the emission reduction will be used by the *JI specific approach*. Below mentioned *JI specific approach* has been used to calculate emission reductions in similar JI projects in the Donbass such as “Waste Heap Dismantling in Luhansk Region of Ukraine with the Aim of Reduction Greenhouse Gases Emissions to Atmosphere” (ITL project ID: UA1000327¹¹), and it

¹⁰ [Guidance on criteria for baseline setting and monitoring, version 03 \(JISC 26\).](http://ji.unfccc.int/Ref/Documents/Baseline_setting_and_monitoring.pdf)
http://ji.unfccc.int/Ref/Documents/Baseline_setting_and_monitoring.pdf

¹¹ <http://ji.unfccc.int/JIITLProject/DB/MWT8YE8A68MBKRG48QJ8Q4O44M7BVY/details>



is updated and verified by Accredited Independent Entity (Bureau Veritas Certification Holding SAS) and Joint Implementation Supervisory Committee.

The baseline study will be fulfilled every year of the emission reduction purchasing, to correct adjustment factors which have an influence at the baseline. For more detailed information see **section D.1.**

Step 1: Identify technically feasible baseline scenario alternatives to the project activity

Project participants have chosen the following approach regarding baseline setting, defined in the Guidance (Paragraph 9):

- An approach for baseline setting and monitoring developed in accordance with appendix B of the JI guidelines (JI specific approach).

The above indicated approach is mentioned in the Paragraph 12 of the Guidance. The detailed theoretical description of the baseline in a complete and transparent manner, as well as a justification in accordance with Paragraph 23 through 29 of the Guidance should be provided by the project participants.

The baseline for this project shall be established in accordance with appendix B of the JI guidelines. Furthermore, the baseline shall be identified by listing and describing plausible future scenarios on the basis of conservative assumptions and selecting the most plausible one.

The most plausible future scenario will be identified by performing a barrier analysis. Should only two alternatives remain, of which one alternative to represent the project scenario with the JI incentive, the CDM Tool "[Tool for the demonstration and assessment of additionally](#)" version 6.0.0. shall be used to prove that the project scenario cannot be regarded as the most plausible one. Key factors that affect the baseline such as sectoral reform policies and legislation, economic situation/growth and socio-demographic factors as well as decreasing and/or increasing demand to be met by the project, availability of capital, technologies/techniques, skills and know-how availability of best available technologies/techniques in the future, fluctuations in fuel prices, national and/or subnational expansion plans for the energy sector will be taken into account while formulating the plausible future scenarios.

Step 2: Eliminate baseline options that do not comply with legal or regulatory requirements

On the basis of the alternatives that are technically feasible and in compliance with all legal and regulatory requirements, the project participant should establish a complete list of barriers that would prevent alternatives to occur in the absence of JI. Show that the identified barriers would not prevent the implementation of at least one of the alternatives to the proposed JI project activity.

Step 3: Eliminate baseline alternatives that face barriers

If there are several potential baseline scenario candidates that do not face barriers: (1) either choose the most conservative (results in least emissions) alternative as the baseline scenario; or (2) choose the economically most attractive alternative (using Step 4).

Step 4: Identify the most economically attractive baseline scenario alternative (optional)

Determine which of the remaining project alternatives that are not prevented by any barrier is the most economically or financially attractive, and thus is the most plausible baseline scenario.

Step 2 Application of the approach chosen



Plausible future scenarios will be identified in order to establish a baseline.

Sub-step 2a. Identify technically feasible baseline scenario alternatives to the project activity

The baseline scenario alternatives should include all technically feasible options which are realistic and credible. These options should include the JI project activity not implemented as a JI project. The options are:

Scenario 1. Continuation of existing situation

The situation before the project was installed, without beneficiation plant and waste heap dismantling. In the current situation waste heaps are not utilized. Coal contained in the waste heaps is not a subject of extraction and; as a result, spontaneous self-heating and subsequent burning of waste heaps leading to uncontrolled GHG emissions is very common. Coal is produced by underground mines that causes fugitive emissions of methane as well as the formation of new waste heaps.

Scenario 2. Direct energy production from the heat energy of burning waste heap

Some burning heaps are used to produce energy by direct insertion of heat exchangers into the waste heap¹². This captures a certain amount of heat energy for direct use or conversion into electricity. Coal for industrial use is not extracted from the waste heaps under this scenario. Coal is produced by underground mines of the region and used for energy production or other purposes. Mining activities, result in fugitive gas release, and the formation of more waste-heaps.

Scenario 3. Production of construction materials from waste heap matter

Waste heaps are being processed in order to produce construction materials (bricks, panels, etc.). Coal in the waste heap matter is burnt during the agglomeration process¹³. Coal is produced by underground mines of the region and used for energy production or other purposes. Mining activities, result in fugitive gas release, and the formation of more waste-heaps.

Scenario 4. Systematic monitoring of waste heaps condition, regular fire prevention and application of extinguishing measures

Waste heaps are systematically monitored and their thermal condition is observed. Regular fire prevention measures are taken. Coal is not extracted from the waste heaps, but is produced by underground mines and used for energy production or other purposes. Mining activities, result in fugitive gas release, and the formation of more waste-heaps.

Scenario 5. Coal extraction from waste heaps without JI incentives

Although this scenario is similar to the project activity only the project itself does not benefit from the possible development as a joint implementation project. In this scenario waste heaps are processed in order to extract coal and use it in the energy sector. Less coal is produced by underground mines of the region.

¹²Method to utilize energy of the burning waste heaps, Melnikov S.A., Zhukov Y.P., Gavrilenko B.V., Shulga A.Y., State Committee Of Ukraine For Energy Saving, 2004

(<http://www.masters.donntu.edu.ua/2004/fgtu/zayanchukovskaya/library/artcl3.htm>)

¹³ Opportunities for international best practice use in coal mining waste heap utilization of Donbas, Matveeva N.G., Ecology: Collection of Scientific Papers, Eastern Ukrainian National University, Luhansk, #1 2007
http://www.nbu.gov.ua/portal/natural/Ecology/2007_1/Article_09.pdf



Sub-step 2b. Eliminate baseline alternatives that face barriers

Scenario 1. Continuation of existing situation

This scenario does not anticipate any activities and therefore does not face any barriers.

Scenario 2. Direct energy production from the heat energy of burning waste heap

Technological barrier: This scenario is based on highly experimental technology, which has not been implemented even in a pilot project. It is also not suitable for all waste heaps as the project owner will have to balance the energy resource availability (i.e. waste heap location) and the location of the energy user. On-site generation of electricity addresses also requires additional interconnection engineering. In general this technology has yet to prove its viability. In addition it does not allow controlling and management of emitted gases.

Investment barrier: Investment into unproven technology result in a high risk. In Ukraine, which ranked as a high risk country¹⁴, investment into such kind of energy projects is unlikely to attract investors. The pioneering character of the project may require the development programs and governmental incentives and the cost of the produced energy is likely to be much higher than alternatives.

Scenario 3. Production of construction materials from waste heap matter

Technological barrier: This scenario is based on known technology, which, however, is not currently available in Ukraine and there is no evidence that such projects will be implemented in the near future. It is also not suitable for all types of waste heaps as the content of waste heap has to be predictable in order for project owner to be able to produce quality materials¹⁵. High content of sulphur and moisture can reduce the suitability of the waste heap for processing. A large scale and detailed exploration of the waste heap has to be performed prior to the start the project.

Scenario 4. Systematic monitoring of waste heaps condition and regular fire prevention and extinguishing measures

Technological barrier: Among the well-known methods to assess the scale of the problem and choose the best direction of fire suppression are: drilling, application of an inert material, injection of inhibitors, compaction, pumping of water, timely reclamation, and recycling. The major drawbacks of these technologies include: difficulties with determination of exact location of self-heating and burning points; lack of special techniques and equipment (e.g. bulldozers and excavators); additional burden on the environment (emissions, dust, smoke); waste heap is not in working condition at the site of work; the lack of guarantees for quick elimination of fire; complication of working conditions; insufficient water can act as one of the factors intensifying the combustion, etc.¹⁶

Investment barrier: This scenario does not represent any revenues but anticipates additional costs for waste heaps owners. Monitoring of the waste heap status is not carried out systematically and actions are left to the discretion of the individual owners, such as mines or regional coal mining associations. However, coal mines in Ukraine suffer from limited funding resulting in safety problems (due to

¹⁴ AMB Country Risk Report: Ukraine October 29, 2010 <http://www3.ambest.com/ratings/cr/reports/Ukraine.pdf>

¹⁵ Opportunities for international best practice use in coal mining waste heap utilization of Donbas, Matveeva N.G., Ecology: Collection of Scientific Papers, Eastern Ukrainian National University, Luhansk, #1 2007 http://www.nbu.gov.ua/portal/natural/Ecology/2007_1/Article_09.pdf

¹⁶ <http://www.imcmontan.ru/team/publication/coal.pdf>



complicated mining conditions) and financial constraints, with miners' salaries often being delayed by few months.¹⁷ From a commercial view point the fines that are usually levied by the authorities are considerably lower than the costs of all the measures outlined by this scenario.

Scenario 5. Coal extraction from waste heaps without JI incentives

Investment barrier: This scenario is financially unattractive and faces barriers. Please refer to section B.2 for details.

Sub- step 2c. Identify the most economically attractive baseline scenario alternative (optional)

Not necessary, as there is only one alternative to the project scenario after sub-step 2b.

Conclusion

In conclusion, the baseline scenario is the continuation of the status quo, which is the continuation of the situation before the project was installed, without beneficiation plant and waste heap dismantling.

This baseline scenario has been established according to the criteria outlined in the JISC Guidance:

- 1) On a project specific basis;
- 2) In a transparent manner with regard to the choice of approaches, assumptions, methodologies, parameters, data sources and key factors. All parameters and data are either monitored by the project participants or are taken from sources that provide a verifiable reference for each parameter. Project participants use approaches suggested by the JISC Guidance and methodological tools provided by the CDM Executive Board;
- 3) Taking into account relevant national and/or sectoral policies and circumstances, such as sectoral reform initiatives, local fuel availability, power sector expansion plans, and the economic situation in the project sector. It is demonstrated by the above analysis that the baseline chosen clearly represents the most probable future scenario given the circumstances of modern day Luhansk coal sector;
- 4) In such a way that emission reduction units (ERUs) cannot be earned for decreases in activity levels outside the project activity or due to force majeure. According to the proposed approach emission reductions will be earned only when project activity will generate coal from the waste heaps, so no emission reductions can be earned due to any changes outside of project activity.
- 5) Taking account of uncertainties and using conservative assumptions. A number of steps have been taken in order to account for uncertainties and safeguard conservativeness:
 - a. Same approaches as used for the calculation of emission levels in the National Inventory Reports (NIRs) of Ukraine are used to calculate baseline and project emissions when possible. NIRs use the country specific approaches and country specific emission factors that are in line with default IPCC values;
 - b. Lower range of parameters is used for calculation of baseline emissions and higher range of parameters is used for calculation of project activity emissions;

¹⁷ Coal Sector of Ukraine: Problems and Sustainable Development Perspectives, Yuri Makogon, National Institute For Strategic Research, 2008 (<http://www.niss.gov.ua/Monitor/desember08/5.htm>)



c. Default values were used to the extent possible in order to reduce uncertainty and provide conservative data for emission calculations.

Calculation of the baseline

In order to calculate baseline emissions following assumptions were made:

- 1) The project will produce carbonaceous fraction, which contains energy coal that will displace the same amount of the same type of coal in the baseline scenario;
- 2) The coal that is displaced in the baseline scenario and the coal that is generated in the project activity are used for the same type of purpose and is stationary combusted;
- 3) The coal that is displaced in the baseline scenario is produced by the underground mines of the region and as such causes fugitive emissions of methane;
- 4) The technology of production coal in the mine involves using a large amount of electricity;
- 5) Coal production in mine is accompanied by consumption of other energy sources (gas, diesel, fuel oil), but their share in compare with electricity are small¹⁸;
- 6) Waste-heaps of the region are vulnerable to spontaneous self-heating and burning and at some point in time will burn;
- 7) The waste heaps that the project is dismantling are categorized as being at risk of ignition. This means that they will self-heat and start burning under normal circumstances. Coal burning in the waste heaps will oxidize to CO₂ completely if allowed to burn uncontrolled.
- 8) The processed rock is not vulnerable to self-heating and spontaneous ignition after the coal has been removed during the processing.
- 9) The correction factor is applied in order to address the uncertainty of the waste heaps burning process. This factor is defined on the basis of the survey of all the waste heaps in the area that provides a ratio of waste heaps that are or have been burning at any point in time to all existing waste heaps.

Baseline emissions come from 2 major sources:

- 1) Carbon dioxide emissions that occur during combustion of energy coal. These are calculated as stationary combustion emissions from coal in the equivalent of the amount of coal that is extracted from the waste heaps in the project scenario. This emission source is also present in the project scenario and the emissions are assumed to be equal in both project and baseline scenario. Therefore, this emission source is not included into consideration both in the project and the baseline scenarios.
- 2) Carbon dioxide emissions from burning waste heaps. These are calculated as stationary combustion emissions from coal in the equivalent of the amount of coal that is extracted from the waste heaps in the project scenario, adjusted by the probability of a waste heap burning at any point in time. As the baseline suggests that the current situation is preserved regarding the waste heaps burning, and the waste heaps in question are at risk of burning it is assumed that actual burning will occur. The correction factor is applied in order to address the uncertainty of the waste heaps burning process. This factor is defined on the basis of the survey of all the waste heaps in the area providing a ratio of waste heaps that are or have been burning at any point in time to all existing waste heaps. These emissions are calculated as:

- Emissions of carbon dioxide generated by burning coal waste heaps, the equivalent amount of coal extracted from the waste heap in the project scenario, adjusted for the probability of burning waste heaps at any time;

¹⁸ *The effective method of electricity consumption control at coal mines. B.A.Gryaduschy, Doctor of Technical Science, DonUGI, G.N.Lisovoy, V.I.Myalkovsky, Chehlaty NA, Cand. Science, NIIGM named M.M.Fedorov, Donetsk, Ukraine www.mishor.esco.co.ua/2005/Thesis/10.doc*

The table below provides values for parameters used to determine the baseline emissions.

<i>Data / Parameter</i>	<i>Data unit</i>	<i>Description</i>	<i>Data Source</i>	<i>Value 2008</i>	<i>Value 2009</i>	<i>Value 2010</i>
GWP_{CH_4}	tCO ₂ e/t CH ₄	Global Warming Potential of Methane	IPCC Second Assessment Report ¹⁹	21		
ρ_{WHB}	ratio	Correction factor for the uncertainty of the waste heap burning process	Scientific research was verified and confirmed by accredited independent entities ²⁰	For Luhansk Region - 0.78 For Donetsk Region - 0.83		
NCV_{coal}	GJ/t	Net Calorific Value of coal	National Inventory Report of Ukraine 1990-2010 ²¹ p. 456, 462, 468	21.50	21.80	21.60
$OXID_{COAL}$	ratio	Carbon Oxidation factor of coal	National Inventory Report of Ukraine 1990-2010 p. 459, 465, 471	0.963	0.963	0.962
k^C_{coal}	tC/TJ	Carbon content of coal	National Inventory Report of Ukraine 1990-2010 p. 458, 464, 470	25.95	25.97	25.99
A_{Coal}	%	The average ash content of coal produced in Ukraine	Guide of quality, volume of coal production and enrichment products in 2008–2010, Ministry of Coal Industry of Ukraine, State Committee of Ukraine	2008 - 38.60 2009 - 39.20 2010 - 39.70 2011 - 39.80		
W_{Coal}	%	The average moisture of coal produced in Ukraine	Guide of quality, volume of coal production and enrichment products in 2008–2010, Ministry of Coal Industry of Ukraine, State Committee of Ukraine	2008 - 8.60 2009 - 8.20 2010 - 8.30 2011 - 8.30		

Table.3 List of parameters used in the calculations of baseline emissions

Emissions in the baseline scenario are calculated as follows:

$$BE_y = BE_{WHB,y} \quad (\text{Equation 1})$$

where:

BE_y - baseline emissions in period y (tCO₂e),

$BE_{WHB,y}$ - baseline emissions due to burning of the waste heaps in period y (tCO₂).

Baseline Emissions due to burning of the waste heaps, in turn, are calculated as:

$$BE_{WHB,y} = FC_{BE,Coal,y} / 1000 * \rho_{WHB} * NCV_{Coal} * OXID_{Coal} * k^C_{Coal} * 44 / 12 \quad (\text{Equation 2})$$

¹⁹ "IPCC Second Assessment: Climate Change 1995. A Report of the Intergovernmental Panel on Climate Change". Bolin, B. et al. (1995). IPCC website. <http://www.ipcc.ch/pdf/climate-changes-1995/ipcc-2nd-assessment/2nd-assessment-en.pdf>.

²⁰ Report on the fire risk of Donetsk Region's waste heaps, Scientific Research Institute "Respirator", Donetsk, 2012 and Report on the fire risk of Luhansk Region's waste heaps, Scientific Research Institute "Respirator", Donetsk, 2012.

²¹ http://unfccc.int/national_reports/annex_i_ghg_inventories/national_inventories_submissions/items/6598.php



where:

$FC_{BE,Coal,y}$ - amount of coal that has been mined in the baseline scenario and combusted for energy use, equivalent to the amount of coal extracted from the waste heaps in the project activity in period y, t. Calculated by the equation 3 or 4.

ρ_{WHB} - correction factor for the uncertainty of the waste heap burning process, ratio. This factor is defined on the basis of the survey of all the waste heaps in the area that provides a ratio of waste heaps that are or have been burning at any point in time to all existing waste heaps.

NCV_{coal} - net calorific value of coal, GJ/t.

$OXID_{coal}$ - carbon oxidation factor of coal, ratio.

k_{coal}^C - carbon content of coal, tC/TJ.

44/12 - ration between molecular mass of CO₂ and C. Reflect oxidation of C to CO₂.

In order to correctly calculate the amount of energy coal produced in mines and substituted by coal, received by dismantling of waste heap, it is necessary to recount, taking into account different value of ash and moisture content of energy coal and fraction, obtained by dismantling of the waste heaps. If in the mass of carbonaceous rocks we extract moisture and substances that are not burned during combustion, and turn to ash, we obtain the conditional ideal coal with no moisture and ash content. Therefore, to obtain coal with averaged over Ukraine characteristics it is necessary to add to that ideal coal the averaged moisture and ash content. In addition to moisture and ash, the coal (carbonaceous rocks) also contains sulfur, but its amount does not exceed a few percent²², content of it in carbonaceous rocks always less than in coal, extracted from the mine, so to calculate the amount produced in coal mine, which replaced by coal from waste heaps, this value can be neglected. Thus, the amount of coal produced in mines in the baseline scenario is calculated by the equation:

$$FC_{BE,Coal,y} = FR_{Coal,y} * (1 - A_{Rock,y}/100 - W_{Rock,y}/100) / (1 - A_{Coal}/100 - W_{Coal}/100) \quad (\text{Equation 3})$$

Where:

$FR_{Coal,y}$ - amount of sorted fraction, which is extracted from the waste heaps because of the project in a period y, that came to blending with further combustion in thermal power plants, t;

$A_{Rock,y}$ - the average ash content of sorted fractions, which is extracted from waste heap in period y, %;

$W_{Rock,y}$ - the average moisture of sorted fractions, which is extracted from waste heap in period y, %;

A_{Coal} - the average ash content of coal, mined in Ukraine, %;

W_{Coal} - the average moisture of coal, mined in Ukraine, %;

100 - conversion factor from percent to fraction, ratio.

If the average ash content and the average moisture of sorted fraction, which are extracted from the waste heap in the period y, are not available for the developer, or are irregular with a high level of uncertainty (table D.2 of PDD), they are taken equal to the relevant nation indicators, and

$$FC_{BE,Coal,y} = FR_{Coal,y} \quad (\text{Equation 4})$$

Leakage

Leakage is the net change of anthropogenic emissions by sources and/or removals by sinks of GHGs which occurs outside the project boundary, and that can be measured and is directly attributable to the JI project.

This project will result in a net change in fugitive methane emissions due to the mining activities and electricity consumption due to coal mining. These leakages are directly attributable to the JI project activity according to the following assumption: the coal produced by the project activity from the waste heap will substitute the coal produced by underground mines of the region in the baseline scenario. This

²² <http://masters.donntu.edu.ua/2009/feht/semkovskiy/library/article9.htm>



assumption is explained by the following logic: Energy coal market is demand driven as it is not feasible to produce coal without demand for it. Coal is a commodity that can be freely transported to the source of demand and coal of identical quality can substitute some other coal easily. The project activity cannot influence demand for coal on the market and supplies coal extracted from the waste heaps. In the baseline scenario demand for coal will stay the same and will be met by the traditional source – underground mines of the region. Therefore, the coal supplied by the project in the project scenario will have to substitute the coal mined in the baseline scenario. It is also important to mention that Ukraine is a net exporter of energy coal so the coal produced by the project activity will substitute domestically mined coal (in 2010 energy coal production was 40.3 Mt, import was 3 Mt and export was 6.1 Mt²³). According to this approach equivalent product supplied by the project activity (with lower associated specific green-house gas emissions) will substitute the baseline product (with higher associated specific green-house gas emissions).

These leakages are measurable: through the same procedure as used in 2006 IPCC Guidelines²⁴ (See Volume 2, Chapter 4, Page 4-11) and also used in CDM approved methodology ACM0009²⁵ (Page 8). Activity data (in our case amount of coal extracted from the waste heap which is monitored directly) is multiplied by the emission factor (which is sourced from the relevant national study - National Inventory Report²⁶ of Ukraine under the Kyoto Protocol) and conversion coefficients. It is important to mention that IPCC and relevant National Inventories take into account raw amount of coal that is being mined in these calculations whereas in the PDD coal extracted from the waste heaps is high quality coal concentrate. Therefore, approach taken in the PDD is conservative as in coal mining more raw coal should be mined causing more fugitive methane emissions to produce equivalent amount of high quality coal concentrate.

Electricity consumption and related greenhouse gas emissions due to dismantling of waste heap to be taken into account in calculating the project emissions. Carbon dioxide emissions due to electricity consumption in the coal mine way in an amount, equivalent to the design of coal - a leakage, that can be taken into account at base of the State Statistics Committee data²⁷, concerning unit costs of electricity at coal mines in Ukraine in the relevant year.

The criteria for definition of the project boundary are provided in the *Guidance on criteria for baseline setting and monitoring*, JISC 18, Annex 2, paragraph 14. In the case of a JI project aimed at reducing emissions, the project boundary shall:

- (a) Encompass all anthropogenic emissions by sources of GHGs which are:
 - (i) Under the control of the project participants;
 - (ii) Reasonably attributable to the project.

Therefore, fugitive CH₄ emissions from mining activities and CO₂ emission due to electricity consumption at coal mines cannot be included into the project boundary as they are not “Under the control of the project participants”. PDD correctly lists Temp LTD-A LLC as a project participant hosting this project activity. Temp LTD-A LLC is performing the dismantling of the waste heaps, processing waste heap matter with the dense medium cyclone technology. Temp LTD-A LLC does not operate or own any coal mines, therefore, any changes in fugitive methane emissions from mining are not under the direct control of project participants. this reason those leakages were included into the ‘leakages’ category and not considered the baseline emissions. Also, for example, approved CDM

²³ <http://www.uaenergy.com.ua/c225758200614cc9/0/d465824d78686a04c225787000542600>

²⁴ http://www.ipcc-nggip.iges.or.jp/public/2006gl/pdf/2_Volume2/V2_4_Ch4_Fugitive_Emissions.pdf

²⁵ <http://cdm.unfccc.int/UserManagement/FileStorage/K4P3YG4TNQ5ECFNA8MBK20SMR6HTEM>

²⁶ http://unfccc.int/national_reports/annex_i_ghg_inventories/national_inventories_submissions/items/6598.php

²⁷ <http://www.ukrstat.gov.ua/>



methodology ACM0009 “Consolidated baseline and monitoring methodology for fuel switching from coal or petroleum fuel to natural gas” Version 3.2 treats the same emission source as leakages on Page 8 out of 16. It is also worth mentioning that leakage by definition is a “net change of anthropogenic emissions” and can be negative or positive depending on the nature of such change. It is also important to mention that including this particular source into baseline emissions or into leakages does not impact estimated emission reductions.

For the value of Emission factor for fugitive methane emissions from coal mining (25,67 m³/t) the data provided in the National Inventory Report ²⁸of Ukraine 1990-2009, p.90 are used. This document is the official GHG Inventory prepared by the Host Country as part of the reporting requirements of the Kyoto Protocol. The description of this particular emission factor states that it is the weighted average emission factor for the methane emissions from coal mining sourced from the study - Triplett J., Filippov A., Paisarenko A. Inventory of methane emissions from coal mines in Ukraine: 1990-2001. Partnership for Energy and Environmental Reform, 2002²⁹.

These leakages are significant and will be included in the calculation of the project emission reductions. Procedure for ex ante estimate and quantification of this source of leakage is provided below:

<i>Data / Parameter</i>	<i>Data unit</i>	<i>Description</i>	<i>Data Source</i>	<i>Value</i>
GWP_{CH_4}	tCO ₂ e/t CH ₄	Global Warming Potential of Methane	IPCC Second Assessment Report ³⁰	21
ρ_{CH_4}	t/m ³	Methane density	Standard ³¹ (at 20°C and 1 ATM)	0.00067
$EF_{CH_4, CM}$	m ³ /t	Average rate for fugitive methane emissions from coal mining	National Inventory Report of Ukraine 1990-2009, p.90	25.67
$EF_{grid, y}$	kgCO ₂ /kWh	Relevant emission factor for the electricity from the grid ³² in the period y	For the years 2008-2011 – NEIA Orders No.43 dated 28.03.2011, No.62 dated 15.04.2011, No.63 dated 15.04.2011, No.75 dated 12.05.2011	For 1 st class 2008-1.082 2009-1.096 2010-1.093 2011-1.090 For 2 nd class 2008-1.219 2009-1.237 2010-1.225 2011-1.227
$N^E_{Coal, y}$	MWh/t	Average electricity consumption per ton of coal,	Fuel and energy resources of Ukraine, Statistical Yearbook,	2008 - 0.0878 2009 - 0.0905

²⁸ http://unfccc.int/national_reports/annex_i_ghg_inventories/national_inventories_submissions/items/5888.php

²⁹ <http://www.epa.gov/cmop/docs/inventory2002.pdf>

³⁰ "IPCC Second Assessment: Climate Change 1995. A Report of the Intergovernmental Panel on Climate Change". Bolin, B. et al. (1995). IPCC website. <http://www.ipcc.ch/pdf/climate-changes-1995/ipcc-2nd-assessment/2nd-assessment-en.pdf>.

³¹ http://www.ipcc-nggip.iges.or.jp/public/2006gl/pdf/2_Volume2/V2_4_Ch4_Fugitive_Emissions.pdf

³² For the years 2008-2011 – NEIA Orders No.43 dated 28.03.2011, No.62 dated 15.04.2011, No.63 dated 15.04.2011, No.75 dated 12.05.2011
http://neia.gov.ua/nature/control/uk/publish/category?cat_id=111922

	produced in Ukraine in the year y	State Statistics Committee of Ukraine, Kiev 2009-2011 ³³	2010 - 0.0926 2010 - 0.0842
--	--------------------------------------	--	--------------------------------

Table.4 List of parameters used in the calculations of leakage

Leakages in the period y are calculated as follows:

$$LE_y = LE_{CH_4, y} + LE_{EL, y} \tag{Equation 5}$$

Leakages due to fugitive emissions of methane in the mining activities in the period y (tCO₂e).

$$LE_{CH_4, y} = -FC_{BE, Coal, y} * EF_{CH_4, CM} * \rho_{CH_4} * GWP_{CH_4} \tag{Equation 6}$$

where:

$FC_{BE, Coal, y}$ - amount of coal that has been mined in the baseline scenario and combusted for energy use, equivalent to the amount of coal extracted from the waste heaps in the project activity in period y, t. Calculated by the equation 3 or 4.

$EF_{CH_4, CM}$ - average rate for fugitive methane emissions from coal mining, m³/t;

ρ_{CH_4} - methane density, t/m³;

GWP_{CH_4} - Global Warming Potential of Methane, tCO₂e/tCH₄.

Leakages due to electricity consumption at coal mines in a period y, calculated by the equation:

$$LE_{EL, y} = -FC_{BE, Coal, y} * N^E_{Coal, y} * EF_{grid, y} \tag{Equation 7}$$

where:

$FC_{BE, Coal, y}$ - amount of coal that has been mined in the baseline scenario and combusted for energy use, equivalent to the amount of coal extracted from the waste heaps in the project activity in period y, t. Calculated by the equation 3 or 4.

$N^E_{Coal, y}$ - average electricity consumption per ton of coal, produced in Ukraine in the year y, MWh/t

$EF_{grid, y}$ - relevant emission factor for the electricity from the grid in the period y.

Leakages due to consumption of other types of energy in coal mines are insignificant compared to the emissions due to electricity consumption³⁴, so in connection with this, and for reasons of conservatism, take them equal to zero.

The key information and data used to establish the baseline (variables, parameters, data sources etc.) are presented below.

Data/Parameter	$FC_{BE, Coal, y}$
Data unit	t
Description	Amount of coal that has been mined in the baseline scenario and combusted for energy use, equivalent to the amount of coal extracted from the waste heaps in the project activity in period y
Time of determination/monitoring	Monthly
Source of data (to be) used	Data of the company
Value of data applied	As provided by the project owner

³³ <http://www.ukrstat.gov.ua/>

³⁴ www.mishor.esco.co.ua/2005/Thesis/10.doc



(for ex ante calculations/determinations)	
Justification of the choice of data or description of measurement methods and procedures (to be) applied	Calculated by the equation 3 or 4 in Section B.1.
QA/QC procedures (to be) applied	N/A
Any comment	

Data/Parameter	$FR_{Coal,y}$
Data unit	t
Description	Amount of sorted fraction, which is extracted from the waste heap because of the project activity in the period y
Time of determination/monitoring	Monthly
Source of data (to be) used	Data of the company. The car weights
Value of data applied (for ex ante calculations/determinations)	As provided by the project owner
Justification of the choice of data or description of measurement methods and procedures (to be) applied	Measured by car weights for the commercial purposes on site. Car weights are passed periodic calibration and verification by national standards.
QA/QC procedures (to be) applied	According to the national standards.
Any comment	

Data/Parameter	$A_{Rock,y}$
Data unit	%
Description	Average ash content of sorted fraction , which is extracted from waste heap in period y
Time of determination/monitoring	Annually
Source of data (to be) used	Data of the company.
Value of data applied (for ex ante calculations/determinations)	As provided by the project owner
Justification of the choice of data or description of measurement methods and procedures (to be) applied	Laboratory research
QA/QC procedures (to be) applied	According to the national standards.
Any comment	If the average ash content and the average moisture of sorted fraction, which are extracted from the waste heap in the period y, are not available for the developer, or are irregular with a high



	level of uncertainty, they are taken equal to the relevant nation indicators.
--	---

Data/Parameter	$W_{Rock,y}$
Data unit	%
Description	Average moisture of sorted fraction , which is extracted from waste heap in period y
Time of determination/monitoring	Annually
Source of data (to be) used	Data of the company.
Value of data applied (for ex ante calculations/determinations)	As provided by the project owner
Justification of the choice of data or description of measurement methods and procedures (to be) applied	Laboratory research
QA/QC procedures (to be) applied	According to the national standards.
Any comment	If the average ash content and the average moisture of sorted fraction, which are extracted from the waste heap in the period y, are not available for the developer, or are irregular with a high level of uncertainty, they are taken equal to the relevant nation indicators.

B.2. Description of how the anthropogenic emissions of greenhouse gases by sources are reduced below those that would have occurred in the absence of the JI project:

Anthropogenic emissions of greenhouse gases in the project scenario will be reduced due to remove the source of green-house gas emissions from the burning / slow burning waste heap by the extraction of non-combusted coal contained in a waste heap and reduce fugitive emissions of methane due to the replacement of coal that would have been mined, by the coal extracted from the heap under the project activity

Additionality of the project

The demonstration that the project provides reductions in emissions by sources that are additional to any that would otherwise occur uses the following step-wise approach:

Step 1. Indication and description of the approach applied

a) If a JI specific approach is used, please explicitly indicate which of the approaches to demonstrate additionality, defined in paragraph 44 of the annex I to the “Guidance on criteria for baseline setting and monitoring”, is chosen, and provide a justification of its applicability, with a clear and transparent description, as well as references, as appropriate.

b) If an approved CDM baseline and monitoring methodology is used in accordance with paragraph 10 of the .Guidance on criteria for baseline setting and monitoring., please provide clear references (e.g. title of the baseline and monitoring methodology or tool, relevant version of the methodology or tool etc.) and describe why and how it is applicable.

Step 2. Application of the approach chosen

The Ukraine signed the Kyoto Protocol on 15 March 1999, and projects from 1 January 2000 are eligible under JI. The proposed project faces serious barriers as described above and is not considered the



baseline scenario. The project was first developed after discussions in 2006 between the project developer and JI experts.

According to Paragraph 44 of Annex 1 to the Guidance on criteria for baseline setting and monitoring Version 03³⁵, approach B has been selected for demonstration of this project's additionality:

(b) Provision of traceable and transparent information that an accredited independent entity has already positively determined that a comparable project (to be) implemented under comparable circumstances (same GHG mitigation measure, same country, similar technology, similar scale) would result in a reduction of anthropogenic emissions by sources or an enhancement of net anthropogenic removals by sinks that is additional to any that would otherwise occur and a justification why this determination is relevant for the project at hand.

Selected approach, including its feasibility must be justified as a basis for the determination referred to in paragraph 33 of the Annex to decision 9/CMP.1 on guidelines for implementation of Article 6 of the Kyoto Protocol.

To support the choice of baseline and demonstrate additionality comparable JI projects are chosen such as "Waste heaps dismantling with the aim of decreasing the greenhouse gases emissions into the atmosphere" and "Processing of waste heaps at Monolith-Ukraine" (ITL project ID: UA2000020 and UA2000034 respectively). In the checking of this approach, designated focal point (DFP) carefully evaluated and reviewed the reliability and accuracy of all data, rationale, assumptions, opinions and documents submitted by participants of similar projects to support the choice of baseline and demonstrate additionality. Elements that are checked during this assessment and relevant conclusions transparently referred to in the conclusion of the determination /verification. Appropriate documentations such as PDD, Determination Report and Monitoring Report, Verification Report regarding these projects are available traceably and transparently on the UNFCCC JI.

- 1) The above mentioned projects have same GHG mitigation measure, same country, similar technology, similar scale. The proposed and comparative projects suggest **same GHG mitigation measure**: The proposed GHG mitigation measure under projects is coal extraction from the mine's waste heaps. This will prevent greenhouse gas emissions into the atmosphere during combustion of the heaps and will contribute an additional amount of coal, without the need for mining.
- 2) The proposed and comparative projects are implemented within the **same country**: Projects are located in Ukraine.
- 3) The proposed and comparative projects utilize **similar technology**: The technology utilized by the projects is similar. In projects the waste heap is dismantled using standard excavators and bulldozers. Trucks are used to move the waste heap matter to the processing facility. The processing facility in projects is the coal beneficiation plant that utilizes several technologies to separate coal from the rest of the matter. Projects use gravity separation method. Gravity separation is an industrial method of separating two components from a suspension or any other homogeneous mixture where separating the components with gravity is sufficiently practical.
- 4) The proposed and comparative projects have **similar scale**: Projects are large scale JI projects. Both projects process waste heaps of comparable scale. Nominal capacity of the processing plant is comparable in the proposed and comparative projects and is 100000 tonnes of material per month. The scale of coal extraction is limited by the coal content of the waste heap matter and the size of the waste heaps.

³⁵ http://ji.unfccc.int/Ref/Documents/Baseline_setting_and_monitoring.pdf



Thus the criteria identified by the Guidance are satisfied and the identified project is indeed a comparable projects implemented under comparable circumstances.

Projects "Waste heaps dismantling with the aim of decreasing the greenhouse gases emissions into the atmosphere" and "Processing of waste heaps at Monolith-Ukraine" (ITL project ID: UA2000020 and UA2000034 respectively) and the proposed project are implemented within the same geographic region of Ukraine – the Donbas coal mining region. The implementation timeline is quite similar. Projects will share the same investment profile and market environment. These projects are implemented by private companies with no utilization of public funds. The investment climate will be comparable in both cases with the coal sector being an almost non-profitable sector in Ukraine³⁶ burdened by many problems. The market for the extracted coal will also be similar for projects as these are small private companies that will not be able to sell coal in big quantities under long-term contracts. Ukrainian coal sector is largely state-controlled. Energy and Coal Ministry of Ukraine decides production level of state mines, based on their performance. After this, state controlled mines sell their coal to the state Trading Company "Coal of Ukraine". This company also buys coal from private mines and arranges supply of coal to thermal electricity companies. Prices for coal mines differ significantly for public and private mines. In general, prices of state mines are more than 60% higher than the prices for private enterprises³⁷.

The proposed and comparative project also shares the investment climate of Ukraine which is far from being favourable. Ukraine is considered to be a high risk country for doing business and investing in. Almost no private capital is available from domestic or international capital markets for mid to long term investments, and any capital that is available has high cost. The table below represents risks of doing business in Ukraine according to various international indexes and studies.

Indicators	2008	2011	Note
Corruption index of Transparency International ³⁸	134 position from 180	152 position from 182	Index of corruption
Rating of business practices of The World Bank (The Doing Business) ³⁹	139 position from 178	145 position from 183	Rating of conduct of business (ease of company opening, licensing, staff employment, registration of ownership, receipt of credit, defence of interests of investors)
The IMD World Competitiveness Yearbook ⁴⁰	54 position from 55	57 position from 59	Research of competitiveness (state of economy, efficiency of government, business efficiency and state of infrastructure)
Index of Economic Freedom of Heritage Foundation ⁴¹	133 position from 157	163 position from 179	Determination of degrees of freedom of economy (business, auction, financial, monetary, investment, financial, labour freedom, freedom from Government, from a corruption, protection of ownership rights)

³⁶ http://www.necu.org.ua/wp-content/plugins/wp-download_monitor/download.php?id=126

³⁷ http://www.ier.com.ua/files/publications/Policy_papers/German_advisory_group/2009/PP_09_2009_ukr.pdf

³⁸ http://cpi.transparency.org/cpi2011/in_detail/

³⁹ <http://www.doingbusiness.org/rankings>

⁴⁰ <http://www.imd.org/research/publications/wcy/upload/scoreboard.pdf>

⁴¹ <http://www.heritage.org/index/ranking>

Global Competitiveness Index of World Economic Forum ⁴²	72 position from 134	82 position from 142	Competitiveness (quality of institutes, infrastructure, macroeconomic stability, education, development of financial market, technological level, innovative potential)
--	----------------------	----------------------	---

Table.5 International ratings of Ukraine Indicators 2008 and 2011

The data above shows that both real and perceived risks of investing in Ukraine are in place and influence the availability of capital in Ukraine both in terms of size of the investments and in terms of capital costs.

As stated at the OECD Roundtable on Enterprise Development and Investment Climate in Ukraine⁴³, the current legal basis is not only inadequate, but to a large extent it sabotages the development of market economy in Ukraine. Voices in the western press can basically be summarized as follows: The reforms in the tax and legal systems have improved considerably with the adoption of the commercial Code, Civil Code and Customs Code on 1 January 2004 and new Tax Code on 1 January 2011 but still contain unsatisfactory elements and pose a risk for foreign investors⁴⁴. Ukraine is considered to be heading in the right direction with significant reforms having been put into action but still has a long way to go to realize its full potential. Frequent and unpredictable changes in the legal system along with conflicting and inconsistent Civil and Commercial Codes do not allow for a transparent and stable enforced legal business environment. Also new Tax Code has caused many disputes of the international community.⁴⁵ Due with its adoption only beginning of 2011 is difficult to assess the quality of the changes and improvements introduced by them in the formation a business environment. This is perceived as a great source of uncertainty by international companies, which make future predictions of business goals and strategy risky.

The conclusion from the abovementioned is as follows: the investment climate of Ukraine is risky and unwelcoming, private capital is not available from domestic or international sources or available at prohibitively high cost due to real and perceived risks of doing business in Ukraine as shown by various sources. Alternatives markets, such as Russia, offer similar profile of investment opportunities with lower risk and better business environment.

Outcome of the analysis: We have provided traceable and transparent information. Accredited independent entity has already positively determined that a comparable projects implemented under comparable circumstances (same GHG mitigation measure, same country, similar technology, similar scale) would result in a reduction of anthropogenic emissions by sources or an enhancement of net anthropogenic removals by sinks that is additional to any that would otherwise occur and have provided justification on why this determination is relevant for the project at hand. Therefore, this project is additional.

B.3. Description of how the definition of the project boundary is applied to the project:

The project activities are physically limited to the waste heaps in the legal use of Temp LTD-A LLC. At the same time, some sources of GHG emissions are indirect - fugitive methane emissions as the result of coal mining in Ukraine, carbon dioxide emissions due to the consumption of power from the Ukrainian

⁴² <http://reports.weforum.org/global-competitiveness-2011-2012/>

⁴³ <http://www.oecd.org/dataoecd/26/20/37051145.pdf>

⁴⁴ *Foreign Direct Investment in Ukraine – Donbass, Philip Burris, Problems of foreign economic relations development and attraction of foreign investments: regional aspect., ISSN 1991-3524, Donetsk, 2007. p. 507-510*

⁴⁵ <http://62.149.1.99/buznes-ekonomuka/20782-reakciya-zapadnoj-pessy-na-novvj-nalegovyj-kodeks-v-ukraine.html>

electricity grid, as a result of electricity generation using fossil fuels. Fugitive methane emissions and electricity consumption as the result of coal mining in Ukraine are treated as leakages.

The table below shows an overview of all emission sources in the baseline and project scenarios and the leakage that occurs during the project activity. Project boundary has been delineated in accordance with provisions of Paragraphs 11, 12, 13 of the Guidance.

	Source	Gas	Included/Excluded	Justification / Explanation
Baseline	Waste heap burning	CO ₂	Included	Main emission source
	Coal consumption	CO ₂	Excluded	This coal is displaced in the project activity by the coal extracted from the waste heaps. This emission source is equal to the one present in the project scenario and, therefore is excluded from consideration.
Project scenario	Coal consumption	CO ₂	Excluded	This coal is extracted from the waste heaps. This emission source is equal to the one present in the baseline scenario and, therefore is excluded from consideration.
	Electricity use for the process of coal extraction from the waste heap	CO ₂	Included	Indirect emissions. Main emission source
	Fossil fuel (diesel) consumption for the process of coal extraction from the waste heap	CO ₂	Included	Main emission source
Leakages	Fugitive methane due to coal mining in the mines	CH ₄	Included	These leaks are taking place in the baseline scenario associated with the uncontrolled leakage of methane in the mine
	Consumption of electricity due to mining	CO ₂	Included	Leakages due to baseline activity
	Use of other types of energy resources due to mining	CO ₂	Excluded	These leakages are not significant, and also for reasons of conservatism, they are excluded from consideration.

Table.6 Sources of emissions in the baseline and project scenarios and leakages of GHG

Baseline scenario

The baseline scenario is the continuation of the existing situation. Coal is produced by the underground mines and is used for energy generation. Waste heaps are often self-heating and burning that causes carbon dioxide emissions into the atmosphere.

Emission sources in the baseline that are included into the project boundary are:

- Carbon dioxide emissions from the burning of coal in the waste heaps.
- Emissions of carbon dioxide due to consumption of coal for energy production. Carbon dioxide emissions that occur during the combustion of energy coal are calculated as stationary combustion emissions from coal in the equivalent of the amount of coal that is extracted from the waste heaps in the project scenario. This emission source is also present in the project scenario and the emissions are assumed to be equal in both project and baseline scenario. Therefore, this emission source is not included into consideration both in the project and the baseline scenario.

Project scenario

In the project scenario waste heaps under processing are taken down and all combustible matter is extracted. Therefore, the possibility of emissions due to spontaneous self-heating and burning of the waste heaps is eliminated. Project activity anticipates combustion of auxiliary diesel fuel to supply coal extraction plant with rock from the waste heaps. Electricity is used to run the project equipment. Additional coal provided by the project reduces the need for coal to be mined from underground.

Emission sources in the project scenario:

- Carbon dioxide emissions from the use of fuel to run part of the project equipment (motor cars),
- Carbon dioxide emissions associated with the electricity consumption by the project equipment.
- Carbon dioxide emissions that occur during the combustion of energy coal are calculated as stationary combustion emissions from coal in the equivalent of the amount of coal that is extracted from the waste heaps in the project scenario. This emission source is also present in the baseline scenario and the emissions are assumed to be equal in both project and baseline scenario. Therefore, this emission source is not included into consideration both in the project and the baseline scenario.

Leakage

Emission sources are:

- fugitive methane emissions due to the mining activities
- emissions of carbon dioxide due to consumption of electricity and other forms of energy in coal mining in the mine.

The following figures show the project boundaries and sources of emissions in the baseline scenario and in the project scenario.

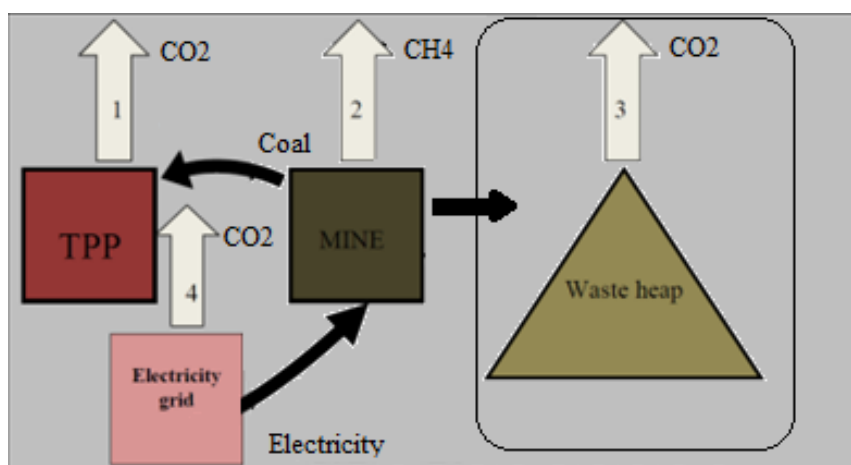

Fig.8 Project boundaries in the baseline scenario

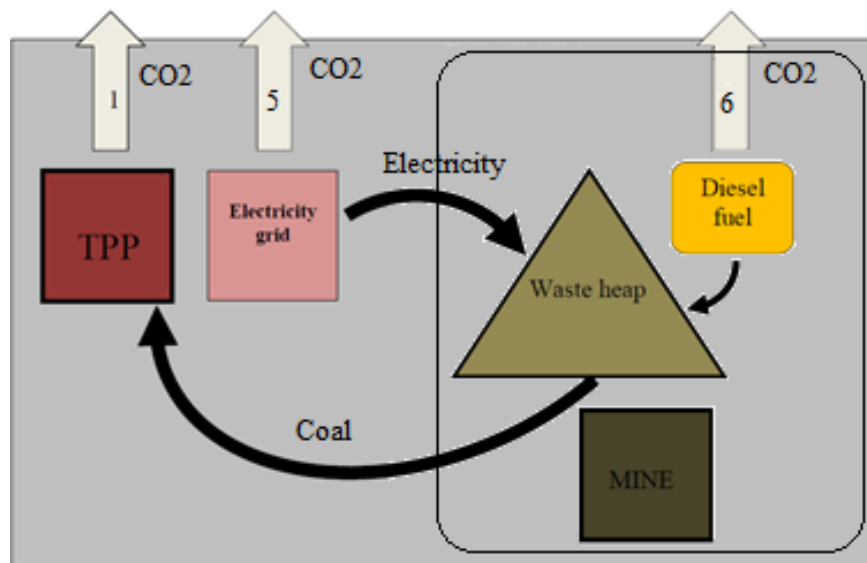
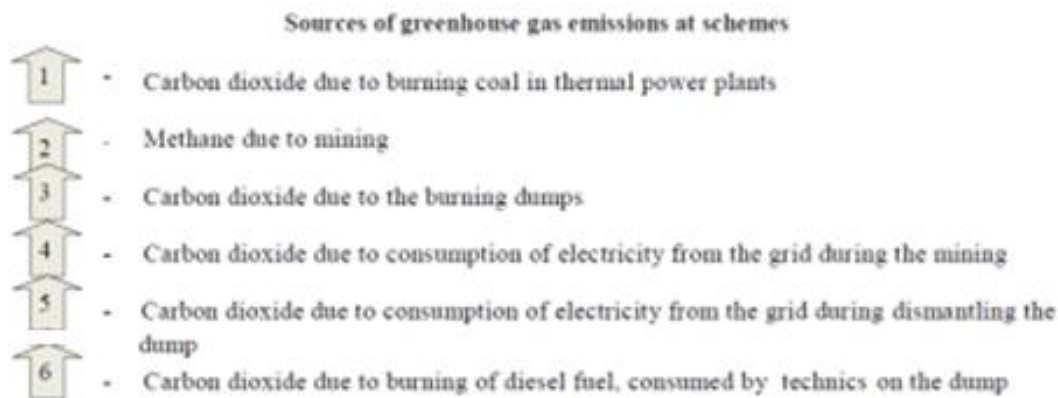

Fig.9 Project boundaries in the project scenario



B.4. Further baseline information, including the date of baseline setting and the name(s) of the person(s)/entity(ies) setting the baseline:

Date of completion of baseline setting: 05/12/2008

Contact information of the entity and persons responsible:
Mr. Tahir Musayev, project manager, Carbon Capital Services Limited,
Email t.musayev@gmail.com Tel/Fax: +38 044 490 6968.
Carbon Capital Services Limited is not a project participant listed in annex 1.

**SECTION C. Duration of the project / crediting period****C.1. Starting date of the project:**

Starting date of the project is 05/12/2008

The starting date of a JI project activity is the date on which the implementation or construction or real action of the project begins. This date is the date of commissioning of the main equipment.

C.2. Expected operational lifetime of the project:

The lifetime of the project is estimated to last until the end of 2022. Thus the operational lifetime of the project will be 14 years and 1 month or 169 months.

C.3. Length of the crediting period:

Start of the crediting period: 05/12/2008.

This is the date of operation start.

Length of first crediting period: 4 years and 1 month or 49 months.

The first crediting period ends in line with the first commitment period under the Kyoto Protocol, 31/12/2012. Emission reductions generated after the crediting period may be used in accordance with an appropriate mechanism under the UNFCCC. The crediting period can extend beyond 2012 subject to the approval by the Host Party. Taking this possible extension into account the length of the crediting period starting on the 05/12/2008 and ending on the 31/12/2022 will be 14 years and 1 month or 169 months.

**SECTION D. Monitoring plan****D.1. Description of monitoring plan chosen:**

In accordance with annex 1 to the JI guidelines and following the guidance on criteria for baseline setting and monitoring⁴⁶ version 3, the monitoring plan is described below, using the following step-wise approach. However, the monitoring plan, is totally based on the JI specific approach, which was listed as a JI specific approach.

Step 1 Indication and description of the approach chosen regarding monitoring

There is no approved CDM baseline and monitoring methodology which is applicable – without revisions being applied – to abandoned mines. Therefore, a JI specific approach (a) is applied.

JI specific approach

In accordance with the guidance the monitoring plan shall provide for:

- (i) The collection and archiving of all relevant data necessary for estimating or measuring anthropogenic emissions of GHGs occurring within the project boundary during the crediting period;
- (ii) The collection and archiving of all relevant data necessary for determining the baseline of anthropogenic emissions of GHGs within the project boundary during the crediting period;
- (iii) The identification of all potential sources of, and the collection and archiving of data on increased anthropogenic emissions of GHGs outside the project boundary that are significant and reasonably attributable to the project during the crediting period. The project boundary shall encompass all anthropogenic emissions of GHGs under the control of the project participants that are significant and reasonably attributable to the JI project;
- (iv) The collection and archiving of information on environmental impacts, in accordance with procedures as required by the host Party, where applicable;
- (v) Quality assurance and control procedures for the monitoring process;
- (vi) Procedures for the periodic calculation of the reductions of anthropogenic emissions by the proposed JI project, and for leakage effects, if any. Leakage is defined as the net change of anthropogenic emissions of GHGs which occurs outside the project boundary, and that is measurable and attributable to the JI project;

⁴⁶ Guidance on criteria for baseline setting and monitoring, version 03 (JISC 26).



(vii) Documentation of all steps involved in the calculations referred to above.

Step 2 Application of the approach chosen

In accordance with the guidance the monitoring plan provides for:

- (i) The collection and archiving of all relevant data necessary for estimating or measuring anthropogenic emissions of GHGs occurring within the project boundary during the crediting period; and
- (ii) The collection and archiving of all relevant data necessary for determining the baseline of anthropogenic emissions of GHGs within the project boundary during the crediting period.

For any monitoring period the following parameters have to be collected and registered:

1. Additional electricity consumed in the relevant period as a result of the implementation of the project activity

This parameter is registered by a specialized electricity meters. The meters are situated next to the current transformers on the site of the project activity. These meters register all electric energy consumed by the project activity as they are located on the only electrical input available on site. Readings are used in the commercial dealings with the energy supply company. Monthly bills for electricity are available. Regular cross-checks with the energy supply company are performed. Monthly and annual reports are based on the monthly bills.

2. Amount of diesel fuel that has been used for the project activity in the relevant period.

For the metering of this parameter the commercial data of the company are used. Receipts and other accounting data are used in order to confirm the amount of fuel consumed. All fuel consumption is taken into account and is attributed to the project activity. If the data in the commercial documents mentioned are provided in litres rather than in tonnes the data in litres are converted into tonnes using the density of 0,85 kg/l⁴⁷. Regular cross-checks with the suppliers are carried out. The monthly and annual reports are based on these data.

3. Amount of coal that has been extracted from the waste heaps and combusted for energy use in the project activity in the relevant period which is equal to the amount of coal that has been mined in the baseline scenario and combusted for energy use.

3.1. Amount of fraction.

⁴⁷ GOST 305-82 Diesel Fuel. Specifications. 0,85 kg/l is taken as an average between two suggested types of diesel: summer and winter <http://elarum.ru/info/standards/gost-305-82/>



For the metering of this parameter the commercial data of the company are used. Receipts and acceptance certificates from the customers are used in order to confirm the amount of coal restored. Only shipped coal is taken into account and is attributed to the project activity. Weighting of the coal is done on site by the special automobile scales. Regular cross-checks with the customers are performed. The monthly and annual reports are based on these shipment data.

3.2. Ash content and moisture of fraction.

Ash content and moisture fraction is defined accredited for technical competence and independence of the laboratory in accordance with regulations (GOST 11022-95 "Mineral solid fuel. Methods of determination the ash content"⁴⁸, GOST 11014-2001 "Brown coal, hard coal and oil shale. Accelerated methods for determining the moisture"⁴⁹ and GOST 27314-91 «Mineral solid fuel. Methods of determination the moisture content»⁵⁰). Analysis of ash content and moisture fraction is done in the laboratory. Ash content and moisture of coal fraction measured regularly with registration annually certificates.

Thus, there is the collection and archiving of all data required for evaluation or measurement anthropogenic emissions of greenhouse gases within the project crediting period and baseline emissions.

With regards to the emission factor of the electricity system in the Ukraine, the previously established, validated and approved approach is applied and fixed ex-ante (see section B.1.). This factor is subject to monitoring and will be corrected at the stage of writing a monitoring report for the period.

- (iii) The identification of all potential sources of, and the collection and archiving of data on increased anthropogenic emissions of GHGs outside the project boundary that are significant and reasonably attributable to the project during the crediting period. The project boundary shall encompass all anthropogenic emissions of GHGs under the control of the project participants that are significant and reasonably attributable to the JI project.

This project will result in a net change in fugitive methane emissions due to the mining activities. Extraction of coal in the baseline scenario of mines causes uncontrolled methane emissions. They are calculated using a standard country-specific emission factor and the amount of coal produced from waste heaps in the project scenario (which equals the number of coal, which was obtained in the baseline scenario).

- (iv) The collection and archiving of information on environmental impacts, in accordance with procedures as required by the host Party, where applicable.

The host Party does not require the collection and archiving of information on environmental impacts of this project activity type.

⁴⁸ <http://vsesnip.com/Data1/16/16768/index.htm>

⁴⁹ <http://vsesnip.com/Data1/40/40907/index.htm>

⁵⁰ <http://vsesnip.com/Data1/29/29367/index.htm>



(v) Quality assurance and control procedures for the monitoring process.

All measurements are conducted with calibrated measurement equipment according to relevant industry standards. Consumption of electricity, fuels and output of coal are cross checked against sales receipts.

All monthly data is checked and signed off by the JI Project Manager.

(vi) Procedures for the periodic calculation of the reductions of anthropogenic emissions by the proposed JI project, and for leakage effects, if any. Leakage is defined as the net change of anthropogenic emissions of GHGs which occurs outside the project boundary, and that is measurable and attributable to the JI project.

The reductions of anthropogenic emissions by the proposed JI project are calculated and reported by the JI Project Management Team on a monthly basis.

Leakage is calculated using a standard country-specific emission factor and the amount of coal produced from waste heaps in the project scenario (which equals the number of coal, which was obtained in the baseline scenario from coal mining).

Description of the approximate calculation, formulas, parameters, data sources and key factors are presented in D.1.2.2 below. Section D.1.3 are measure of inaccuracy for each parameter.(vii) Documentation of all steps involved in the calculations referred to above.

All data collected as part of the monitoring are archived electronically and kept at least for 2 years after the last transfer of ERUs for the project. All measurements are conducted with calibrated measurement equipment according to relevant industry standards.



Data and parameters that are not monitored throughout the crediting period, but are determined only once (and thus remain fixed throughout the crediting period), and that are available already at the stage of determination, such as:

<i>Data / Parameter</i>	<i>Data unit</i>	<i>Description</i>	<i>Data Source</i>	<i>Value 2008</i>	<i>Value 2009</i>	<i>Value 2010</i>
GWP_{CH_4}	tCO ₂ e/tCH ₄	Global Warming Potential of Methane	IPCC Second Assessment Report ⁵¹	21		
ρ_{CH_4}	t/m ³	Methane density	Standard ⁵² (temperature 20°C and 1 ATM)	0.00067		
NCV_{coal}	GJ/t	Net Calorific Value of coal	National Inventory Report of Ukraine 1990-2010 ⁵³ p. 456, 462, 468	21.50	21.80	21.60
NCV_{diesel}	GJ/t	Net Calorific Value of diesel fuel	National Inventory Report of Ukraine 1990-2010 p. 473,476, 479	42.20	42.20	42.20
$OXID_{COAL}$	ratio	Carbon Oxidation factor of coal	National Inventory Report of Ukraine 1990-2010 p. 459, 465, 471	0.963	0.963	0.962
$OXID_{DIESEL}$	ratio	Carbon Oxidation factor of diesel fuel	National Inventory Report of Ukraine 1990-2010 p. 475, 478, 481	0.99	0.99	0.99
k^C_{coal}	tC/TJ	Carbon content of coal	National Inventory Report of Ukraine 1990-2010 p. 458, 464, 470	25.95	25.97	25.99
k^C_{diesel}	tC/TJ	Carbon content of diesel fuel	National Inventory Report of Ukraine 1990-2010 p. 474, 477,	20.20	20.20	20.20

⁵¹ IPCC Second Assessment: Climate Change 1995. A Report of the Intergovernmental Panel on Climate Change ".Bolin, B. et al. (1995). IPCC website. <http://www.ipcc.ch/pdf/climate-changes-1995/ipcc-2nd-assessment/2nd-assessment-en.pdf>.

⁵² http://www.ipcc-nggip.iges.or.jp/public/2006gl/pdf/2_Volume2/V2_4_Ch4_Fugitive_Emissions.pdf

⁵³ http://unfccc.int/national_reports/annex_i_ghg_inventories/national_inventories_submissions/items/6598.php



			480			
$EF_{grid, y}$	kgCO ₂ /kWh	Relevant emission factor for the electricity from the grid ⁵⁴ in the period y	For the years 2008-2011 – NEIA Orders No.43 dated 28.03.2011, No.62 dated 15.04.2011, No.63 dated 15.04.2011, No.75 dated 12.05.2011		For 1 st class 2008-1.082 2009-1.096 2010-1.093 2011-1.090 For 2 nd class 2008-1.219 2009-1.237 2010-1.225 2011-1.227	
$N_{Coal, y}^E$	MWh/t	Average electricity consumption per ton of coal, produced in Ukraine in the year y	Fuel and energy resources of Ukraine, Statistical Yearbook, State Statistics Committee of Ukraine, Kiev 2009-2011 ⁵⁵	0.0878	0.0905	0.0926
A_{Coal}	%	The average ash content of coal produced in Ukraine	Guide of quality, volume of coal production and enrichment products in 2008–2010, Ministry of Coal Industry of Ukraine, State Committee of Ukraine		2008 - 38.60 2009 - 39.20 2010 - 39.70 2011 - 39.80	
W_{Coal}	%	The average moisture of coal produced in Ukraine	Guide of quality, volume of coal production and enrichment products in 2008–2010, Ministry of Coal Industry of Ukraine, State Committee of Ukraine		2008 - 8.60 2009 - 8.20 2010 - 8.30 2011 - 8.30	
$EF_{CH_4, CM}$	m ³ /t	Average rate for fugitive methane emissions from coal mining	National Inventory Report of Ukraine 1990-2009 p.90		25.67	

⁵⁴ For the years 2008-2011 – NEIA Orders No.43 dated 28.03.2011, No.62 dated 15.04.2011, No.63 dated 15.04.2011, No.75 dated 12.05.2011
http://neia.gov.ua/nature/control/uk/publish/category?cat_id=111922

⁵⁵ <http://www.ukrstat.gov.ua/>



Table.7 List of parameters used in the calculations of emissions

Data and parameters that are not monitored throughout the crediting period, but are determined only once (and thus remain fixed throughout the crediting period), but that are not already available at the stage of determination

<i>Data / Parameter</i>	<i>Data unit</i>	<i>Description</i>	<i>Data Source</i>	<i>Value 2011</i>	<i>Value 2012</i>
NCV_{coal}	GJ/t	Net Calorific Value of coal	National Inventory Report of Ukraine ⁵⁶ p.456, 462, 468	21.60	21.60
NCV_{diesel}	GJ/t	Net Calorific Value of diesel fuel	National Inventory Report of Ukraine p.473,476, 479	42.20	42.20
$OXID_{COAL}$	ratio	Carbon Oxidation factor of coal	National Inventory Report of Ukraine p.459, 465, 471	0.962	0.962
$OXID_{DIESEL}$	ratio	Carbon Oxidation factor of diesel fuel	National Inventory Report of Ukraine p.475, 478, 481	0.99	0.99
k^C_{coal}	tC/TJ	Carbon content of coal	National Inventory Report of Ukraine p.458, 464, 470	25.99	25.99
k^C_{diesel}	tC/TJ	Carbon content of diesel fuel	National Inventory Report of Ukraine p.474, 477, 480	20.20	20.20
$EF_{grid,y}$	kgCO ₂ /kWh	Relevant emission factor for the electricity from the grid ⁵⁷ in the period y	For the years 2008-2011 – NEIA Orders No.43 dated 28.03.2011, No.62 dated 15.04.2011, No.63 dated 15.04.2011, No.75 dated 12.05.2011		For 1 st class 1.090 For 2 nd class 1.227
$N^E_{Coal,y}$	MWh/t	Average electricity consumption per ton of coal, produced in Ukraine in the year y	Fuel and energy resources of Ukraine, Statistical Yearbook, State Statistics Committee of Ukraine, Kiev	0.0842	0.0842

⁵⁶ http://unfccc.int/national_reports/annex_i_ghg_inventories/national_inventories_submissions/items/6598.php

⁵⁷ For the years 2008-2011 – NEIA Orders No.43 dated 28.03.2011, No.62 dated 15.04.2011, No.63 dated 15.04.2011, No.75 dated 12.05.2011
http://neia.gov.ua/nature/control/uk/publish/category?cat_id=111922



$EF_{CH_4, CM}$	m ³ /t	Average rate for fugitive methane emissions from coal mining	National Inventory Report of Ukraine 1990-2009 p.90	25.67
ρ_{WHB}	ratio	Correction factor for the uncertainty of the waste heaps burning process	Scientific research was verified and confirmed by accredited independent entities ⁵⁸	For Luhansk Region - 0.78 For Donetsk Region - 0.83

Table.8 List of parameters used in the calculations of emissions

The data listed in the table are taken based on Table 7 data and are used for approximate calculation in the PDD, but in the monitoring period will be changed to updated data from source documents.

Data and parameters that are monitored throughout the crediting period, such as:

$EC_{PJ,y}$	Additional electricity consumed in year y as a result of the implementation of the project activity
$FC_{PJ,Diesel,y}$	Amount of diesel fuel that has been used for the project activity in period y
$FC_{BE,Coal,y}$	Amount of coal that has been mined in the baseline scenario and combusted for energy use, equivalent to the amount of coal extracted from the waste heaps in the project activity in period y. Calculated by the equation 3 or 4.
$FR_{Coal,y}$	Amount of sorted fraction, which is extracted from the waste heaps because of the project activity in a period y

Table.9 Data and parameters that are monitored throughout the crediting period

Archiving, data storage and record handling procedure

Documents and reports on the data that are monitored will be archived and stored by the project participants. The following documents will be stored: primary documents for the accounting of monitored parameters in paper form; intermediate reports, orders and other monitoring documents in paper and electronic form;

⁵⁸ Report on the fire risk of Donetsk Region's waste heaps, Scientific Research Institute "Respirator", Donetsk, 2012 and Report on the fire risk of Luhansk Region's waste heaps, Scientific Research Institute "Respirator", Donetsk, 2012.



documents on measurement devices in paper and electronic form. These documents and other data monitored and required for determination and verification, as well as any other data that are relevant to the operation of the project will be kept for at least two years after the last transfer of ERUs.

Training of monitoring personnel

The project will utilize technology that requires skills and knowledge in heavy machinery operation, coal beneficiation technology operation, electric equipment operation etc. This kind of skills and knowledge is available locally through the system of vocational training and education. This system is state-supervised in Ukraine. Professionals who graduate from vocational schools receive a standard certificate in the field of their professional study. Only workers with proper training can be allowed to operate industrial equipment like. Management of the project host will ensure that personnel of the project have received proper training and are eligible to work with the prescribed equipment.

Training on safety issues is mandatory and must be provided to all personnel of the project as required by local regulations. Procedure for safety trainings includes the scope of the trainings, training intervals, forms of training, knowledge checks etc. The project host management will maintain records for such trainings and periodic knowledge check-ups.

Activities that are directly related to the monitoring do not require specific training other than provided by the professional education. However, monitoring personnel will receive training on monitoring procedures and requirements. Personnel of the project host management will receive necessary training and consultations on Kyoto Protocol, JI projects and monitoring from the project participant.

Procedures identified for corrective actions in order to provide for more accurate future monitoring and reporting

In cases if any errors, fraud, inconsistencies or situations when monitoring data are unavailable will be identified during the monitoring process special commission will appointed by project host management that will conduct a review of such case and issue an order that must also include provisions for necessary corrective actions to be implemented that will ensure such situations are avoided in future.

The project host management will also establish a communication channel that will make it possible to submit suggestions, improvement proposals and project ideas for more accurate future monitoring for every person involved in the monitoring activities. Such communications will be delivered to the project host management who is required to review these communications and in case it is found appropriate implement necessary corrective actions and improvements. Project participant - - will conduct periodic review of the monitoring plan and procedures and if necessary propose improvements to the project participants. Also, to prevent the situations in which monitoring data are unavailable, all parameters are fixed and saved on paper and electronically in a database the Owner and Developer of the project separately.

Emergency preparedness for cases where emergencies can cause unintended emissions

The project operation does not foresee any factors or emergencies that can cause unintended GHG emissions. Safe operation of equipment and personnel is ensured by systematic safety training. Procedures for dealing with general emergencies such as fire, major malfunction etc. are developed as part of the mandatory business regulations and are in accordance with local requirements.

**D.1.1. Option 1 – Monitoring of the emissions in the project scenario and the baseline scenario:****D.1.1.1. Data to be collected in order to monitor emissions from the project, and how these data will be archived:**

ID number (Please use numbers to ease cross-referencing to D.2.)	Data variable	Source of data	Data unit	Measured (m), calculated (c), estimated (e)	Recording frequency	Proportion of data to be monitored	How will the data be archived? (electronic/ paper)	Comment
1	$EC_{PJ,y}$ Additional electricity consumed in period y as a result of the implementation of the project activity	Data of Company, electricity meters	MWh	m	Monthly	100%	Electronic and paper	This parameter is registered with a specialized electricity meters.
2	$FC_{PJ,Diesel,y}$ Amount of diesel fuel that has been used for the project activity in the period y	Data of Company	t	m	Monthly	100%	Electronic and paper	If the data in the documents mentioned are provided in litres rather than in tonnes the data in litres are converted into tonnes using



								the density of 0,85 kg/l ⁵⁹ .
3	NCV_{diesel} Net Calorific Value of diesel fuel	See section D.1. Fixed ex ante	TJ/kt	e	Fixed ex ante	100%	In electronic form	
4	$OXID_{DIESEL}$ Carbon Oxidation factor of diesel fuel	See section D.1. Fixed ex ante	ratio	e	Fixed ex ante	100%	In electronic form	
5	k^C_{diesel} Carbon content of diesel fuel	See section D.1. Fixed ex ante	tC/TJ	e	Fixed ex ante	100%	In electronic form	
6	$EF_{grid, y}$ Relevant emission factor for the electricity from the grid ⁶⁰ in the period y	See section D.1. Fixed ex ante	tCO ₂ /MWh	e	Fixed ex ante	100%	In electronic form	

The table above includes data and parameters that are monitored throughout the crediting period.

D.1.1.2. Description of formulae used to estimate project emissions (for each gas, source etc.; emissions in units of CO₂ equivalent):

⁵⁹ GOST 305-82 Diesel Fuel. Specifications. 0,85 kg/l is taken as an average between two suggested types of diesel: summer and winter <http://elarum.ru/info/standards/gost-305-82/>

⁶⁰ For the years 2008-2011 – NEIA Orders No.43 dated 28.03.2011, No.62 dated 15.04.2011, No.63 dated 15.04.2011, No.75 dated 12.05.2011 http://neia.gov.ua/nature/control/uk/publish/category?cat_id=111922



Emissions from the project activity are calculated as follows:

$$PE_y = PE_{EL,y} + PE_{Diesel,y} \quad \text{(Equation 8)}$$

where

- PE_y , -project emissions due to project activity in the period y (tCO₂e),
 $PE_{EL,y}$ -project emissions due to consumption of electricity from the grid by the project activity in the period y (tCO₂e),
 $PE_{Diesel,y}$ -project emissions due to consumption of diesel fuel by the project activity in the period y (tCO₂e).

These, in turn, are calculated as:

$$PE_{EL,y} = EC_{PJ,y} * PE_{grid,y} \quad \text{(Equation 9)}$$

where:

- $EC_{PJ,y}$ - additional electricity consumed in period y as a result of the implementation of the project activity, MWh,
 $EF_{grid,y}$ - relevant emission factor for the electricity from the grid in the period y, kgCO₂/kWh (tCO₂/MWh).

$$PE_{Diesel,y} = FC_{PJ,Diesel,y} / 1000 * NCV_{Diesel} * OXID_{Diesel} * k_{Diesel}^C * 44/12 \quad \text{(Equation 10)}$$

where:

- $FC_{PJ,Diesel,y}$ - amount of diesel fuel that has been used for the project activity in the period y, t,
 NCV_{Diesel} - net calorific value of diesel fuel, GJ/t;
 $OXID_{Diesel}$ - carbon oxidation factor of diesel fuel, ratio;
 k_{Diesel}^C - carbon content of diesel fuel, t C/TJ;
 $44/12$ - ration between molecular mass of CO₂ and C. Reflect oxidation of C to CO₂.

D.1.1.3. Relevant data necessary for determining the <u>baseline</u> of anthropogenic emissions of greenhouse gases by sources within the project boundary, and how such data will be collected and archived:								
ID number (Please use numbers to ease cross-	Data variable	Source of data	Data unit	Measured (m), calculated (c), estimated (e)	Recording frequency	Proportion of data to be monitored	How will the data be archived? (electronic/	Comment



referencing to D.2.)							paper)	
7	NCV_{coal} Net Calorific Value of coal	See section D.1. Fixed ex ante	TJ/kt	e	Fixed ex ante	100%	In electronic form	
8	$OXID_{COAL}$ Carbon Oxidation factor of coal	See section D.1. Fixed ex ante	ratio	e	Fixed ex ante	100%	In electronic form	
9	k_{coal}^C Carbon content of coal	See section D.1. Fixed ex ante	tC/TJ	e	Fixed ex ante	100%	In electronic form	
10	$FC_{BE,Coal,y}$ - Amount of coal that has been mined in the baseline scenario and combusted for energy use, equivalent to the amount of coal extracted from the waste heaps in the project activity in the period y	Data of calculation	t	c	Monthly	100%	Electronic and paper	Calculated by the equation 3 or 4.



11	$FR_{Coal,y}$ Amount of sorted fraction , which is extracted from the waste heaps because of the project activity in a period y	Data of the company. Car Weights.	t	c	Monthly	100%	Electronic and paper	For the metering of this parameter the commercial data of the company are used. Receipts and acceptance certificates from the customers are used in order to confirm the amount of coal restored.
12	$A_{Rock,y}$ Average ash content of sorted fraction, which is extracted from waste heap in period y	Data of the company. Laboratory research	%	m	Annually	100%	Electronic and paper	Data of the laboratory
13	$W_{Rock,y}$ Average moisture of sorted fraction , which is extracted from waste heap in period y	Data of the company. Laboratory research	%	m	Annually	100%	Electronic and paper	Data of the laboratory

The table above includes data and parameters that are monitored throughout the crediting period.

**D.1.1.4. Description of formulae used to estimate baseline emissions (for each gas, source etc.; emissions in units of CO₂ equivalent):**

Emissions in the baseline scenario are calculated as follows:

$$BE_y = BE_{WHB,y} \quad \text{(Equation 11)}$$

where:

BE_y - baseline emissions in period y (tCO₂e),

$BE_{WHB,y}$ - baseline emissions due to burning of the waste heaps in period y (tCO₂),

$BE_{EL,y}$ - baseline emissions due to consumption of electricity from a grid at coal mine in a period y, (tCO₂).

$BE_{WHBC,y}$ - baseline emissions due to burning of waste heap, created as a result of coal mining during the period y, (tCO₂).

Baseline Emissions due to burning of the waste heaps, in turn, are calculated as:

$$BE_{WHB,y} = FC_{BE,Coal,y} / 1000 * \rho_{WHB} * NCV_{Coal} * OXID_{Coal} * k_{Coal}^C * 44/12 \quad \text{(Equation 12)}$$

where:

$FC_{BE,Coal,y}$ - amount of coal that has been mined in the baseline scenario and combusted for energy use, equivalent to the amount of coal extracted from the waste heaps in the project activity in period y, t. Calculated by the equation 3 or 4.

ρ_{WHB} - correction factor for the uncertainty of the waste heap burning process. This factor is defined on the basis of the survey of all the waste heaps in the area that provides a ratio of waste heaps that are or have been burning at any point in time to all existing waste heaps.

NCV_{coal} - net calorific value of coal, GJ/t.

$OXID_{coal}$ - carbon oxidation factor of coal, ratio.

k_{coal}^C - carbon content of coal, tC/TJ.

$44/12$ - ration between molecular mass of CO₂ and C. Reflect oxidation of C to CO₂.

In order to correctly calculate the amount of energy coal produced in mines and substituted by coal, received by dismantling of waste heap, it is necessary to recount, taking into account different value of ash and moisture content of energy coal and fraction, obtained by dismantling of the waste heaps. If in the mass of carbonaceous rocks we extract moisture and substances that are not burned during combustion, and turn to ash, we obtain the conditional ideal coal with no moisture and ash content. Therefore, to obtain coal with averaged over Ukraine characteristics it is necessary to add to that ideal coal the averaged moisture and



ash content. In addition to moisture and ash, the coal (carbonaceous rocks) also contains sulfur, but its amount does not exceed a few percent⁶¹, content of it in carbonaceous rocks always less than in coal, extracted from the mine, so to calculate the amount produced in coal mine, which replaced by coal from waste heaps, this value can be neglected. Thus, the amount of coal produced in mines in the baseline scenario is calculated by the equation:

$$FC_{BE,Coal,y} = FR_{Coal,y} * (1 - A_{Rock,y} / 100 - W_{Rock,y} / 100) / (1 - A_{Coal} / 100 - W_{Coal} / 100) \quad (\text{Equation 13})$$

Where:

$FR_{Coal,y}$ - amount of sorted fraction, which is extracted from the waste heaps because of the project in a period y, that came to blending with further combustion in thermal power plants, t;

$A_{Rock,y}$ - the average ash content of sorted fractions, which is extracted from waste heap in period y, %;

$W_{Rock,y}$ - the average moisture of sorted fractions, which is extracted from waste heap in period y, %;

A_{Coal} - the average ash content of coal, mined in Ukraine, %;

W_{Coal} - the average moisture of coal, mined in Ukraine, %;

100 - conversion factor from percent to fraction, ratio.

If the average ash content and the average moisture of sorted fraction, which are extracted from the waste heap in the period y, are not available for the developer, or are irregular with a high level of uncertainty (table D.2 of PDD), they are taken equal to the relevant nation indicators, and

$$FC_{BE,Coal,y} = FR_{Coal,y} \quad (\text{Equation 14})$$

D. 1.2. Option 2 – Direct monitoring of emission reductions from the project (values should be consistent with those in section E.):

This section is left blank on purpose, as option 1 is chosen.

⁶¹ <http://masters.donntu.edu.ua/2009/feht/semkovskiy/library/article9.htm>



D.1.2.1. Data to be collected in order to monitor emission reductions from the project, and how these data will be archived:								
ID number <i>(Please use numbers to ease cross-referencing to D.2.)</i>	Data variable	Source of data	Data unit	Measured (m), calculated (c), estimated (e)	Recording frequency	Proportion of data to be monitored	How will the data be archived? (electronic/ paper)	Comment

This section is left blank on purpose, as option 1 is chosen.

D.1.2.2. Description of formulae used to calculate emission reductions from the project (for each gas, source etc.; emissions/emission reductions in units of CO₂ equivalent):
--

This section is left blank on purpose, as option 1 is chosen.

D.1.3. Treatment of leakage in the monitoring plan:
--

Leakage is the net change of anthropogenic emissions by sources and/or removals by sinks of GHGs which occurs outside the project boundary, and that can be measured and is directly attributable to the JI project. Project participants must undertake an assessment of the potential leakage of the proposed JI project and explain which sources of leakage are to be calculated, and which can be neglected. All sources of leakage that are included shall be quantified and a procedure for an ex ante estimate shall be provided.

This project will result in a net change in fugitive methane emissions due to the mining activities and leakages due to electricity consumption at coal mines.

This leakage is significant and will be included in the monitoring plan and calculation of the project emission reductions.



D.1.3.1. If applicable, please describe the data and information that will be collected in order to monitor leakage effects of the project:								
ID number (Please use numbers to ease cross-referencing to D.2.)	Data variable	Source of data	Data unit	Measured (m), calculated (c), estimated (e)	Recording frequency	Proportion of data to be monitored	How will the data be archived? (electronic/ paper)	Comment
6	<i>EF grid, y</i> Relevant emission factor for the electricity from the grid ⁶² in the period y	See section D.1. Fixed ex ante	tCO ₂ /MWh	e	Fixed ex ante	100%	In electronic form	
10	<i>FC_{BE,Coal,y}</i> - Amount of coal that has been mined in the baseline scenario and combusted for energy use, equivalent to the amount of coal extracted from the waste heaps in the project activity in the period y	Data of calculation	t	c	Monthly	100%	Electronic and paper	Calculated by the equation 3 or 4.
11	<i>FR_{Coal,y}</i>	Data of the	t	c	Monthly	100%	Electronic and	For the

⁶² For the years 2008-2011 – NEIA Orders No.43 dated 28.03.2011, No.62 dated 15.04.2011, No.63 dated 15.04.2011, No.75 dated 12.05.2011
http://neia.gov.ua/nature/control/uk/publish/category?cat_id=111922



	Amount of sorted fraction , which is extracted from the waste heaps because of the project activity in a period y	company. Car Weights.					paper	metering of this parameter the commercial data of the company are used. Receipts and acceptance certificates from the customers are used in order to confirm the amount of coal restored.
14	$N_{Coal,y}^E$ Average electricity consumption per ton of coal, produced in Ukraine in the year y	See section D.1. Fixed ex ante	MWh/t	e	Fixed ex ante	100%	In electronic form	
15	$EF_{CH_4, CM}$ Average rate for fugitive methane emissions from coal mining	See section D.1. Fixed ex ante	m ³ /t	e	Fixed ex ante	100%	In electronic form	
16	ρ_{CH_4} Methane density	See section D.1. Fixed ex ante	t/m ³	e	Fixed ex ante	100%	In electronic form	

D.1.3.2. Description of formulae used to estimate leakage (for each gas, source etc.; emissions in units of CO₂ equivalent):

Leakages in the period y are calculated as follows:

$$LE_y = LE_{CH_4, y} + LE_{EL, y} \quad \text{(Equation 14)}$$

Leakages due to fugitive emissions of methane in the mining activities in the period y (tCO₂e).

$$LE_{CH_4, y} = -FC_{BE, Coal, y} * EF_{CH_4, CM} * \rho_{CH_4} * GWP_{CH_4} \quad \text{(Equation 15)}$$

where:

$FC_{BE, Coal, y}$ - amount of coal that has been mined in the baseline scenario and combusted for energy use, equivalent to the amount of coal extracted from the waste heaps in the project activity in period y, t. Calculated by the equation 3 or 4.

$EF_{CH_4, CM}$ - average rate for fugitive methane emissions from coal mining, m³/t;

ρ_{CH_4} - methane density, t/m³;

GWP_{CH_4} - Global Warming Potential of Methane, tCO₂e/tCH₄.

Leakages due to electricity consumption at coal mines in a period y, calculated by the equation:

$$LE_{EL, y} = -FC_{BE, Coal, y} * N^E_{Coal, y} * EF_{grid, y} \quad \text{(Equation 16)}$$

where:

$FC_{BE, Coal, y}$ - amount of coal that has been mined in the baseline scenario and combusted for energy use, equivalent to the amount of coal extracted from the waste heaps in the project activity in period y, t. Calculated by the equation 3 or 4.

$N^E_{Coal, y}$ - average electricity consumption per ton of coal, produced in Ukraine in the year y, MWh/t

$EF_{grid, y}$ - relevant emission factor for the electricity from the grid in the period y, tCO₂/MWh.

Leakages due to consumption of other types of energy in coal mines are insignificant compared to the emissions due to electricity consumption⁶³, so in connection with this, and for reasons of conservatism, take them equal to zero.

⁶³ www.mishor.esco.co.ua/2005/Thesis/10.doc



D.1.4. Description of formulae used to estimate emission reductions for the project (for each gas, source etc.; emissions/emission reductions in units of CO₂ equivalent):

The emission reductions are calculated as follows:

$$ER_y = BE_y - LE_y - PE_y$$

(Equation 17)

where:

ER_y - emissions reductions of the JI project in period y (tCO₂e)

LE_y - leakages in period y (tCO₂e);

BE_y - baseline emission in period y (tCO₂e);

PE_y - project emission in period y (tCO₂e);

D.1.5. Where applicable, in accordance with procedures as required by the host Party, information on the collection and archiving of information on the environmental impacts of the project:

Collection and archiving of the information on the environmental impacts of the project will be done based on the approved EIA in accordance with the Host Party legislation - State Construction Standard DBN A.2.2.-1-2003:"Structure and Contents of the Environmental Impact Assessment Report (EIR) for Designing and Construction of Production Facilities, Buildings and Structures" State Committee Of Ukraine On Construction And Architecture, 2004.

D.2. Quality control (QC) and quality assurance (QA) procedures undertaken for data monitored:

Data (Indicate table and ID number)	Uncertainty level of data (high/medium/low)	Explain QA/QC procedures planned for these data, or why such procedures are not necessary.
D.1.1.1. - ID 1	Low	The electricity meters are calibrated according to the procedures of the Host Party. Calibration interval is 6 years.
D.1.1.1. - ID 2	Low	This data are used in the commercial activity of the company. Accounting documentation will be used.
D.1.1.3. (D.1.3.1.) -ID 10	Low	This data is the calculation of baseline emissions, based on the values of ID 4, ID 5, ID 6.
D.1.1.3.(D.1.3.1.) - ID 11	Low	These data are used in commercial activities of the company. The scales will be calibrated according to the procedures of the Host Party. Calibration interval is 1 year.
D.1.1.3. - ID 12	Low	These data are used in commercial activities of the company. Data of laboratory.
D.1.1.3. - ID 13	Low	These data are used in commercial activities of the company. Data of laboratory.



D.3. Please describe the operational and management structure that the project operator will apply in implementing the monitoring plan:

1. Introduction

The project adopts a JI specific monitoring approach. This monitoring plan describes the responsibilities of the JI Project Management Team and the methods and procedures to be adopted to implement the monitoring plan described in the Project Design Document in respect of this project activity.

2. Project Management & Responsibilities

The operational and management structure (as shown in below the figure) and the responsibilities of the principals are as follows. Ultimate responsibility for the project rests with the JI Project Manager.

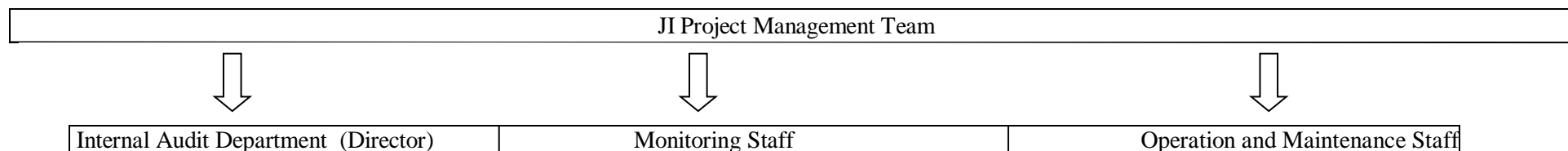

Fig.10 The management structure of the project

The JI Project Manager is responsible for:

- Checking and signing off all project operational-related activities
- Appointing and liaising with the accredited independent entity (AIE)
- Identifying an audit team leader to be appointed by the Chief Engineer or a delegated authority
- Appointing a JI technical team to undertake the operational activities
- Organizing training and refresher courses
- Preparing and supervising a Health and Safety Plan for the JI technical team
- Supervising the work of the JI technical team
- Cross checking reported volumes and sales receipts



Internal Audit Department (Director)

The project owner - Temp LTD-A LLC will implement provisions of this monitoring plan into its organizational and quality management structure. For monitoring, collection, registration, visualization, archiving, reporting of the monitored data and periodical checking of the measurement devices the management team headed by the Director of the company is responsible.

The monitoring staff is responsible for:

- Monitoring and recording of the relevant parameters

The operation and maintenance staff are responsible for:

- Operation and maintenance of the project infrastructure
- Service and maintenance equipment is performed by technical personnel beneficiation plant.

D.4. Name of person(s)/entity(ies) establishing the <u>monitoring plan</u>:
--

Contact information of the entity and persons responsible.

Mr Tahir Musayev, project manager Carbon Capital Services Limited,

Email t.musayev@gmail.com Tel/Fax: +38 044 490 6968.

Carbon Capital Services Limited is not a project participant listed in annex 1.

**SECTION E. Estimation of greenhouse gas emission reductions****E.1. Estimated project emissions:**

The formulas used to estimate the project anthropogenic emissions by sources of greenhouse gas emissions, description of calculations by these formulas and all the assumptions used are described in Section D.1.1.2.

		2008	2009	2010	2011	2012	Total
Project Emissions due to consumption of electricity from the grid by the project activity	tCO ₂ e	264	3156	2744	2764	2177	11105
Project Emissions due to consumption of diesel fuel by the project activity	tCO ₂ e	51	984	1191	1333	960	4519
Total Project emissions during the crediting period	tCO ₂ e	315	4140	3935	4097	3137	15624

Table.10 Estimated project emissions during the crediting period

		Annually from 2013 to 2022	Total
Project Emissions due to consumption of electricity from the grid by the project activity	tCO ₂ e	2177	21770
Project Emissions due to consumption of diesel fuel by the project activity	tCO ₂ e	960	9600
Total Project emissions after the crediting period	tCO ₂ e	3137	31370

Table.11 Estimated project emissions after the crediting period

E.2. Estimated leakage:

The formulas used to estimate the leakage under the project activities, description of calculations by these formulas and all the assumptions used are described in Section D.1.3.

		2008	2009	2010	2011	2012	Total
Leakages due to fugitive emissions of methane in the mining activities in the period y	tCO ₂ e	-20078	-323642	-286472	-317529	-328616	-1276337
Leakages due to consumption of electricity from the grid during mining	tCO ₂ e	-5950	-100314	-89972	-90828	-94000	-381064



Total leakages during the crediting period	tCO ₂ e	-26028	-423956	-376444	-408357	-422616	-1657401
---	--------------------	--------	---------	---------	---------	---------	----------

Table.12 Estimated leakages during the crediting period

		Annually from 2013 to 2022	Total
Leakages due to fugitive emissions of methane in the mining activities in the crediting period	tCO ₂ e	-328616	-3286160
Leakages due to consumption of electricity from the grid during mining	tCO ₂ e	-94000	-940000
Total leakages after the crediting period	tCO ₂ e	-422616	-4226160

Table.13 Estimated leakages after the crediting period

E.3. The sum of E.1. and E.2.:

		2008	2009	2010	2011	2012	Total
Total Project emissions during the crediting period	tCO ₂ e	-25713	-419816	-372509	-404260	-419479	-1641777

Table.14 Estimated total project emissions during the crediting period

		Annually from 2013 to 2022	Total
Total Project emissions after the crediting period	tCO ₂ e	-419479	-4194790

Table.15 Estimated total project emissions after the crediting period

E.4. Estimated baseline emissions:

The formulas used to estimate the baseline anthropogenic emissions by sources of greenhouse gas emissions using the baseline methodology, description of calculations by these formulas and all the assumptions used are described in Section D.1.1.4.

		2008	2009	2010	2011	2012	Total
Baseline Emissions due to burning of the waste heaps	tCO ₂ e	85421	1397223	1225077	1357888	1405303	5470912
Baseline emissions during the crediting period	tCO ₂ e	85421	1397223	1225077	1357888	1405303	5470912

Table.16 Estimated baseline emissions during the crediting period



		Annually from 2013 to 2022	Total
Baseline Emissions due to burning of the waste heaps	tCO ₂ e	1405303	14053030
Baseline emissions after the crediting period	tCO ₂ e	1405303	14053030

Table.17 Estimated baseline emissions after the crediting period

E.5. Difference between E.4. and E.3. representing the emission reductions of the project:

		2008	2009	2010	2011	2012	Total
Emission reductions during the crediting period	tCO ₂ e	111134	1817039	1597586	1762148	1824782	7112689

Table.18 Estimated emission reductions during the crediting period

		Annually from 2013 to 2022	Total
Emission reductions after the crediting period	tCO ₂ e	1824782	18247820

Table.19 Estimated emission reductions after the crediting period

E.6. Table providing values obtained when applying formulae above:

Year	Estimated project emissions (tonnes of CO ₂ equivalent)	Estimated leakage (tonnes of CO ₂ equivalent)	Estimated baseline emissions (tonnes of CO ₂ equivalent)	Estimated emission reductions (tonnes of CO ₂ equivalent)
2008	315	-26028	85421	111134
2009	4140	-423956	1397223	1817039
2010	3935	-376444	1225077	1597586
2011	4097	-408357	1357888	1762148
2012	3137	-422616	1405303	1824782
Total (tonnes of CO ₂ equivalent)	15624	-1657401	5470912	7112689

Table.20 Estimated balance of emissions under the proposed project over the crediting period

Year	Estimated project emissions (tonnes of CO ₂ equivalent)	Estimated leakage (tonnes of CO ₂ equivalent)	Estimated baseline emissions (tonnes of CO ₂ equivalent)	Estimated emission reductions (tonnes of CO ₂ equivalent)
2013	3137	-422616	1405303	1824782
2014	3137	-422616	1405303	1824782



2015	3137	-422616	1405303	1824782
2016	3137	-422616	1405303	1824782
2017	3137	-422616	1405303	1824782
2018	3137	-422616	1405303	1824782
2019	3137	-422616	1405303	1824782
2020	3137	-422616	1405303	1824782
2021	3137	-422616	1405303	1824782
2022	3137	-422616	1405303	1824782
Total (tonnes of CO ₂ equivalent)	31370	-4226160	14053030	18247820

Table.21 Estimated balance of emissions under the proposed project after the crediting period

**SECTION F. Environmental impacts****F.1. Documentation on the analysis of the environmental impacts of the project, including transboundary impacts, in accordance with procedures as determined by the host Party:**

According to the Ukrainian law "On the ecological examination" all projects that can result in violation of ecological norms and/or negative influence on the state of natural environment are subject to ecological examination. The proposed project in general has a positive impact on the environment so is not subject to special ecological examination.

Waste heaps that are burning or are close to spontaneous ignition are sources of uncontrolled greenhouse gas and hazardous substances emissions. The latter include sulphurous anhydride that transforms into sulphur acid and is the reason for acid rains, hydrogen sulphide and carbon oxide. Ground water is contaminated with solid particles, becomes hard and acid when it contacts a waste heap. Erosion processes that often destroy the integrity of the waste heaps account for contamination of nearby areas with particles that contain hazardous materials (like sulphur). Erosion can lead overtime to the total destruction of a waste heap in a massive landslide that is dangerous both in terms of direct hazard to population and property as well as massive emissions of particles and hazardous substances into the atmosphere. Erosion also helps to intensify the process of spontaneous combustion. Combustion of coal in the waste heap is rather long-term and lasts from 5 to 7 years.

Avoidance of combustion of these waste heaps will result in improvement of the ecological situation in the region, reduction of CO₂ emissions and other hazardous substances. Breaking down the waste heaps will also help to prevent ground water contamination. This will also increase areas of agricultural area and general development of lands by levelling the terrain on the site of abandoned open-pits.

The full scope EIA in accordance with the Ukrainian legislation has been conducted for the proposed project in 2006 for the waste heaps processing facility by the local developer Ltd. Scientific and industrial design company "Alyans". Key findings of this EIA are summarized below:

- Impact on air is the main environmental impact of the project activity. Dust emissions due to the erosion and project activity such as loading and offloading operations of input rock and processed coal will be limited. Also emissions from transport will be present during the project operation stage. The impact will not exceed maximum allowable concentration at the edge of the sanitary zone;
- Impact on water is minor. The project activity will use water in a closed cycle without discharge of waste water. The possible discharge of the processed water will not have negative impact on the quality of water in the surface reservoirs;
- Impacts on flora and fauna are insignificant. The design documentation demands re-cultivation of the landscape. Grass and trees will be planted on the re-cultivated areas in order to prevent flora and fauna degradation. No rare or endangered species will be impacted. Project activity is not located in the vicinity of national parks or protected areas;
- Noise impact is limited. Main source of noise will be located at the minimum required distance from residential areas, mobile noise sources (automobile transport) will be in compliance with local standards;
- Impacts on land use are positive. Significant portions of land will be freed from the waste heaps and will be available for development. Fertile soil will be used to recultivate the land lot;



- Transboundary impacts are not observed. There are no impacts that manifest within the area of any other country and that are caused by a proposed project activity which wholly physically originates within the area of Ukraine.

The list of available EIA documentation includes:

1. Project of the waste heap processing complex building. *Volume I: Explanatory note. Book 3, Environmental Impact Assessment.* Ltd. Scientific and industrial design company "Alyans", Kharkiv, 2006.

Beside the positive effect on the global climate protection, no transboundary impacts occur.

F.2. If environmental impacts are considered significant by the project participants or the host Party, please provide conclusions and all references to supporting documentation of an environmental impact assessment undertaken in accordance with the procedures as required by the host Party:

In a result of environmental impact analysis, held under F.1, it is concluded that there are no significant environmental impacts expected.



SECTION G. Stakeholders' comments

G.1. Information on stakeholders' comments on the project, as appropriate:

No stakeholder consultation process for the JI projects is required by the Host Party. Stakeholder comments will be collected during the time of this PDD publication in the internet during the determination procedure.

Annex 1**CONTACT INFORMATION ON PROJECT PARTICIPANTS**

Organisation:	Limited Liability Company Temp LTD-A
Street/P.O.Box:	Artema
Building:	33
City:	Luhansk
State/Region:	Luhansk region
Postal code:	94601
Country:	Ukraine
Phone:	+38 (064) 313-62-60
Fax:	+38 (064) 313-54-02
E-mail:	templtd-a@ukr.net
URL:	http://temp-ltda.business-guide.com.ua/
Represented by:	
Title:	Legal Counsel
Salutation:	Mr
Last name:	Karuna
Middle name:	Sergijovich
First name:	Serhiy
Department:	-
Phone (direct):	+38 (06431) 3-54-02
Fax (direct):	+38 (06431) 3-62-60
Mobile:	-
Personal e-mail:	templtd-a@ukr.net



<u>Organisation:</u>	Ohana LLP
<u>Street/P.O.Box:</u>	35A Windmill Lane
<u>Building:</u>	
<u>City:</u>	Epsom
<u>State/Region:</u>	Surrey
<u>Postal code:</u>	KT17 3AN
<u>Country:</u>	United Kingdom
<u>Phone:</u>	+44 208 786 0751
<u>Fax:</u>	+44 208 786 0751
<u>E-mail:</u>	tw@ohanallp.com
<u>URL:</u>	www.ohanallp.com
<u>Represented by:</u>	Thomas Winklehner
<u>Title:</u>	
<u>Salutation:</u>	Mr.
<u>Last name:</u>	Winklehner
<u>Middle name:</u>	
<u>First name:</u>	Thomas
<u>Department:</u>	
<u>Phone (direct):</u>	+44 208 786 0751
<u>Fax (direct):</u>	+44 208 786 0751
<u>Mobile:</u>	+44 7834 370 265
<u>Personal e-mail:</u>	tw@ohanallp.com



Annex 2

BASELINE INFORMATION

Key information and data used to establish the baseline (variables, parameters, data sources) are provided below in tabular form:

#	Parameter	Data unit	Source of data
1	$FC_{BE,Coal,y}$ Amount of coal that has been mined in the baseline scenario and combusted for energy use, equivalent to the amount of coal extracted from the waste heaps in the project activity in the period y	t	Calculation by the equation 3 or 4.
2	$EF_{CH_4,CM}$ Emission factor for fugitive methane emissions from coal mining.	m ³ /t	National Inventory Report of Ukraine 1990-2009
3	ρ_{WHB} Correction factor for the uncertainty of the waste heaps burning process.	ratio	Scientific research was verified and confirmed by accredited independent entities
4	GWP_{CH_4} Global Warming Potential of Methane	tCO ₂ e/tCH ₄	IPCC Second Assessment Report
5	ρ_{CH_4} Methane density	t/m ³	Standard (temperature 20°C and 1 ATM)
6	NCV_{coal} Net Calorific Value of coal	GJ/t	National Inventory Report of Ukraine
7	$OXID_{COAL}$ Carbon Oxidation factor of coal	Dimensionless	National Inventory Report of Ukraine
8	k^C_{coal} Carbon content of coal	tC/TJ	National Inventory Report of Ukraine
9	$FR_{Coal,y}$ Amount of sorted fraction, which is extracted from the waste heap because of the project activity in the period y	t	Data of the company. The car weights
10	$A_{Rock,y}$ Average ash content of sorted fraction, which is extracted from waste heap in period y	%	Data of the company. Laboratory research
11	$W_{Rock,y}$ Average moisture of sorted fraction, which is extracted from waste heap in period y	%	Data of the company. Laboratory research



12	$N_{Coal,y}^E$ Average electricity consumption per ton of coal, produced in Ukraine in the year y	MWh/t	Fuel and energy resources of Ukraine, Statistical Yearbook, State Statistics Committee of Ukraine, Kiev 2009-2011 ⁶⁴
13	A_{Coal} The average ash content of coal produced in Ukraine	%	Guide of quality, volume of coal production and enrichment products in 2008-2010, Ministry of Coal Industry of Ukraine, State Committee of Ukraine
14	W_{Coal} The average moisture of coal produced in Ukraine	%	Guide of quality, volume of coal production and enrichment products in 2008-2010, Ministry of Coal Industry of Ukraine, State Committee of Ukraine
15	$EF_{grid,y}$ Relevant emission factor for the electricity from the grid ⁶⁵ in the period y	kgCO ₂ /kWh	For the years 2008-2011 – NEIA Orders No.43 dated 28.03.2011, No.62 dated 15.04.2011, No.63 dated 15.04.2011, No.75 dated 12.05.2011

⁶⁴ <http://www.ukrstat.gov.ua/>

⁶⁵ For the years 2008-2011 – NEIA Orders No.43 dated 28.03.2011, No.62 dated 15.04.2011, No.63 dated 15.04.2011, No.75 dated 12.05.2011
http://neia.gov.ua/nature/control/uk/publish/category?cat_id=111922



Annex 3

MONITORING PLAN

For the monitoring plan please refer to section D of this PDD.