

SEVENTH PERIODIC JI MONITORING REPORT

Version 1.0
2 February 2011

CONTENTS

- A. General project activity and monitoring information
- B. Key monitoring activities
- C. Quality assurance and quality control measures
- D. Calculation of GHG emission reductions

SECTION A. General Project activity information

A.1 Title of the project activity:

“Improvement of the Energy efficiency at Energomashspetsstal (EMSS), Kramatorsk, Ukraine”.

A.2. JI registration number:

JI 0104

A.3. Short description of the project activity:

The project activity consists of the energy efficiency measures at the premises of EMSS through the implementation of four subprojects:

Subproject 1. Reconstruction of thermal and heating furnaces – there are thermal and heating furnaces in operation in different shops at the premises of EMSS. The main goal of this subproject is the reduction of the natural gas (NG) consumption for 26 of these furnaces by commissioning of new automated NG burners (which enables the required temperature inside of the furnace to be maintained) and by the implementation of new thermal insulation for the walls, front doors and roofs of the furnaces.

Subproject 2. Installation of a new vacuum system – The installation of a new vacuum system for the vacuumed steel production. The old vacuum system used heat and electricity, the new reconstructed vacuum system uses only electricity.

Subproject 3. Installation of an arc ladle furnace – The installation of a new arc ladle furnace for the steel production. This means that the part of the process of the steel preparation will be undertaken in the ladle, from which the steel will be cast into the forms. As a result there is reduction of the electricity consumption.

Subproject 4. Modernization of press equipment – The replacement of an old pump system, serving the 15.000 ton press, with a new more effective pump system. There are 24 old pumps (with 500 kW installed capacity each), which will be replaced by 11 new pumps (with 800 kW installed capacity each).

A.4. Monitoring period:

- Monitoring period starting date: 01.10.2010 at 00:00;
- Monitoring period closing date: 31.12.2010 at 24:00.

A.5. Methodology applied to the project activity (incl. version number):

A.5.1. Baseline methodology: The “Guidance on criteria for baseline setting and monitoring”, issued by the Joint Implementation Supervisory Committee allows using approved methodologies of the CDM. The PDD, determined by an AIE, used a JI project specific approach to establish baseline scenario.

A.5.2. Monitoring methodology: A JI-specific monitoring approach was developed for this project in line with the “Guidance on criteria for baseline setting and monitoring”. The resulting Monitoring Plan was determined as part of the determination process.

A.6. Status of implementation including time table for major project parts:

Sub Project 1 implementation is behind schedule due to a lack of financing, detailed forecast and actual dates are shown in the table below:

Activity	Date of start up according to PDD	Date of start up actual
Subproject 1. Reconstruction of thermal and heating furnaces		

Activity	Date of start up according to PDD	Date of start up actual
Thermal #1, Thermal workshop	2007	2007
Thermal #2, Thermal workshop	2007	2007
Thermal #9, Thermal workshop	2007	2007
Thermal #10, Thermal workshop	2007	2007
Thermal #30, Forge Press workshop	April 2008	May 2008
Thermal #18, Forge Press workshop	July 2008	December 2008
Heating #7, Forge Press Workshop	July 2008	October 2008
Heating #8, Forge Press Workshop	2007	2007
Heating #9, Forge Press Workshop	2007	2007
Heating #10, Forge Press Workshop	2007	February 2008
Thermal #19, Forge Press workshop	September 2008	February 2009
Thermal #20, Forge Press workshop	October 2008	March 2009
Thermal #21, Forge Press workshop	October 2008	August 2009
Thermal #32, Forge Press workshop	October 2008	July 2009
Heating #33, Forge Press workshop	October 2008	September 2009
Thermal #37, Forge Press workshop	August 2009	September 2009
Thermal #4, Thermal workshop	December 2008	11 January 2010
Heating #34, Forge Press workshop	December 2008	1 January 2010
Heating #35, Forge Press workshop	May 2009	19 January 2010
Heating #36, Forge Press workshop	August 2009	1 March 2010
Thermal #38, Forge Press workshop	August 2009	1 May 2010
Subproject 2. Installation of a new vacuum system	May 2007	February 2008
Subproject 3. Installation of an arc ladle furnace	April 2007	April 2007
Subproject 4. Modernization of press equipment	December 2007	August 2008

Table 1: Status of implementation (according to PDD)

The numbers of furnaces are correlated to the numbers in the original MSEXcel sheet “ER calculation and Cash Flow Analysis English”¹.

A.7. Intended deviations or revisions to the determined PDD:

There are few deviations to the monitoring plan included in the determined PDD. Detailed descriptions of the deviations are given in the Monitoring Report 002 that has been finally verified (see http://ji.unfccc.int/JI_Projects/DeterAndVerif/Verif/FinVerif.html). A revised monitoring plan has been submitted to the AIE during verification, which received a positive determination.

¹http://ji.unfccc.int/JI_Projects/DB/VY889VYDTR7YGFRTY9TXLB4AWBLUR/Determination/Bureau%20Veritas%20Certification1246891334.73/viewDeterminationReport.html

There were also changes during the implementation of the project. Their detailed analysis in accordance with Procedures Regarding Changes During Project Implementation² developed by JISK is provided in the Annex 1 to the **Monitoring Report 006 that has been finally verified (provide a link)**.

A.8. Intended deviations or revisions to the determined monitoring plan:

There are no deviations to the determined monitoring plan.

A.9. Changes since last verification:

There are no changes since last verification.

A.10. Person(s) responsible for the preparation and submission of the monitoring report:

OJSC “Energomashspetsstal”

- Alexander Masyuk, Deputy Chief Engineer

Global Carbon B.V.

- Lennard de Klerk, Director
- Anna Vilde, JI Consultant

² http://ji.unfccc.int/Sup_Committee/Meetings/022/Reports/Annex2.pdf

SECTION B. Key monitoring activities according to the monitoring plan for the monitoring period stated in A.4.

Key monitoring activities for each subproject could be described as follows.

Subproject 1. Reconstruction of thermal and heating furnaces. Each reconstructed furnace has a natural gas flow meter with pressure and temperature sensors in order to calculate normal cubic meters of natural gas burned in the furnace. Information from flow meters, pressure and temperature sensors are transmitting to the control and monitoring computer system where recalculation to the normal cubic meters taking place according to the approved standard.

All information about technological process is saved continuously. The archiving period for the log files is at least one year. Information that corresponds to the natural gas consumption in fourth quarter 2010 has been burned on CDs. These CDs are stored till the end of the crediting period plus two years.

Every half-finished product that processes through the furnaces has own unique certificate. This certificate reflects all operations performed on the product and the weight on the exit of every workshop. So, the weight of half-finished products that proceed through each furnace could be easily monitored. Information from the certificates is saved in the log books in order to simplify the monitoring process.

A report including natural gas consumption and weight of half finished products is generating on a monthly basis. The report is signing by Head of Energy Saving Department, Head of corresponding workshop and approved by Chief Engineer.

The natural gas meters (flow, pressure, temperature) are used in furnaces' control process. That is why any deviation/failure of the meters would be recognized immediately by disturbance of the heating process and reported to the workshop's head. As a result of disturbance furnace should be shut down for the checking procedure.

The flowcharts of the natural gas supplying system with the metering points are presented in the following figures.

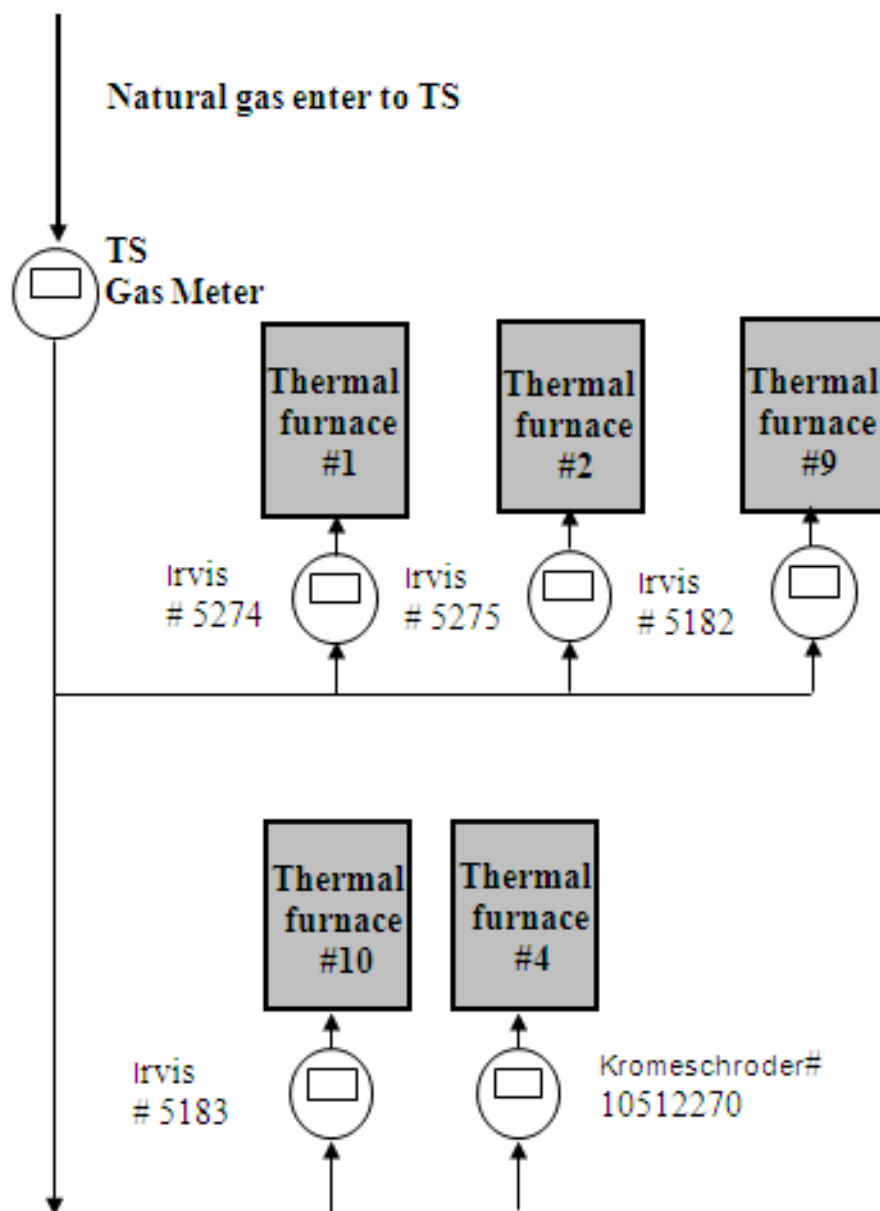

Figure 1. Natural gas metering system at the thermal workshop (TS)

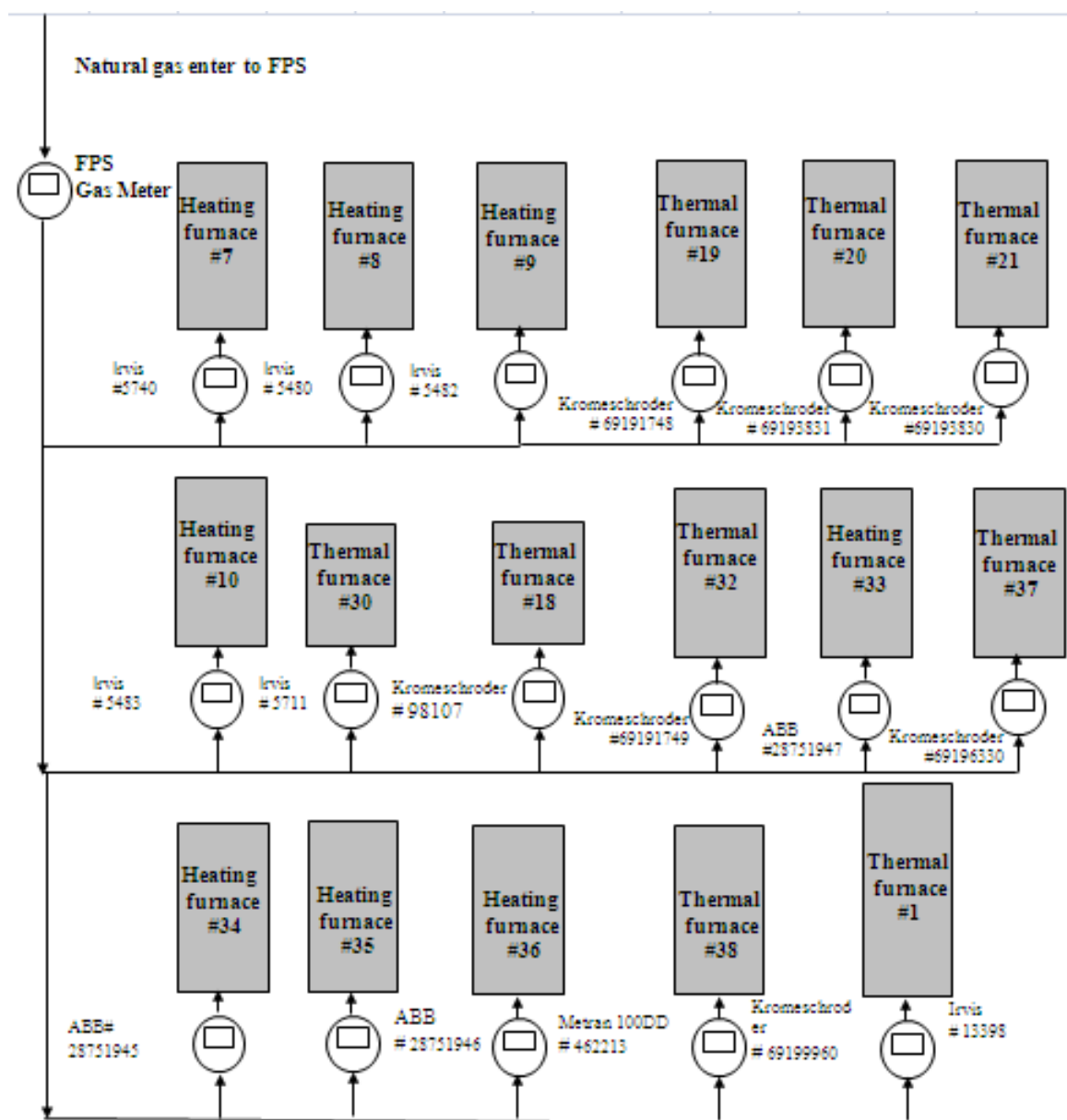

Figure 2. Natural gas metering system at Forge Press workshop (FPS)

Subproject 2. Installation of a new vacuum system.

Electricity that is consumed during the vacuum process is metered using dedicated meters for this system. Information from meters is passed to the control and monitoring computer system of the vacuumator. A computer system records information about every vacuumization session, including melt passport, time and electricity consumption. The archiving period for the log files is at least one year. Information that corresponds to the electricity consumption in the fourth quarter 2010 has been burned on CDs. These CDs are stored till the end of the crediting period plus two years.

Correctness of the meters' work is checking by the following formulae:

$$\sum(\text{meter5} + \text{meter6}) - \sum(\text{meter1} + \text{meter2} + \text{meter3} + \text{meter4} + \text{other consumers}) \leq 1.5\%$$

In the case of a difference of more than 1.5%, a verification of meters is performed, if found defective, the meter is substituted within one day.

The steel to the vacuum degasser (VD) is coming either from ladle furnace (LF) or from the electric arc furnace (EAF) in special ladle. Each ladle with liquid steel has unique certificate of melt. The following figure presents the electricity supplying system to the VD with metering points.

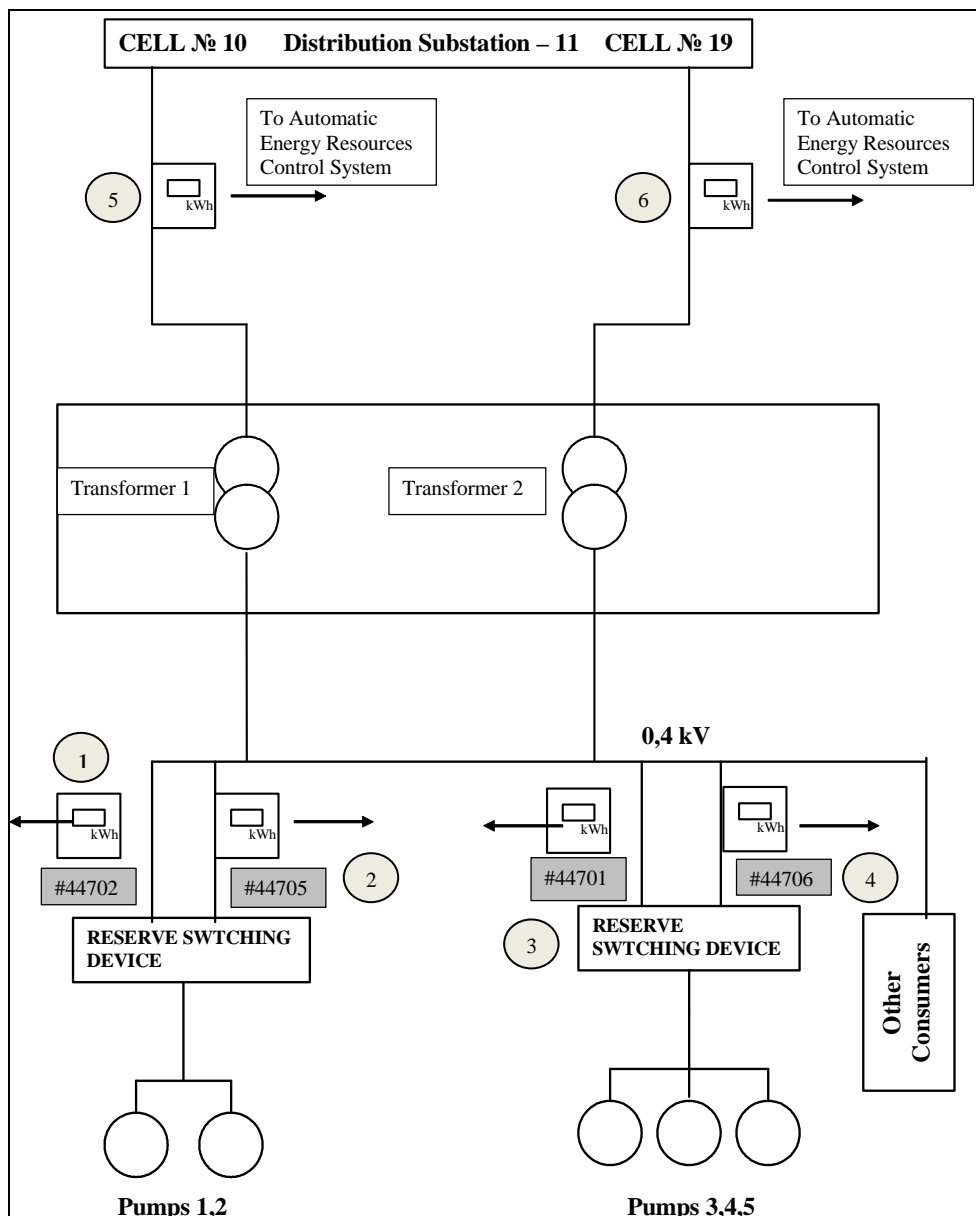

Figure 3. Electricity metering system at VD

Subproject 3. Installation of an arc ladle furnace.

LF is a comprehensive solution for high quality steel melting has been installed in the Steel Making Workshop (SMW). The main electricity consumers of the SMW are powered by the following scheme.

Close Distribution Unit (CDU) #1, 2 are electricity powering points for the EAFs (EAF50 #1, EAF100 #3, EAF100 #5 and EAF12) and LF. CDUs are powered by Transformers (T1, and T2) and Autotransformers (AT1 and AT2). EAFs and LF could be powered from any of the Transformers or Autotransformers. Commercial electricity meters are installed on each of the Transformers and Autotransformer. Cross-checking of the meters is performed by the following formulae:

$$\sum(AT1+ AT2 +T1 + T2) - \sum(EAF50 \#1 + EAF100 \#3 + EAF100 \#5+ EAF12+LF) \leq 1.5\%$$

In the case of a difference of more than 1.5%, a verification of meters is performed, if found defective, the meter is substituted within one day.

The data from electricity meters concerning electricity consumption is transmitted to the control and monitoring computer system continuously. The computer system records information about each melt process, including melt certificate. This certificate includes information about the number of EAF where steel was melted, steel content, amount of electricity consumed during melting and weight of steel. The archiving period for the log files is at least one year. All melt certificates for the fourth quarter of the year 2010 have been burned to CDs. These CDs are stored until the end of the crediting period plus two years.

The following figure presents electricity supplying system with metering points.

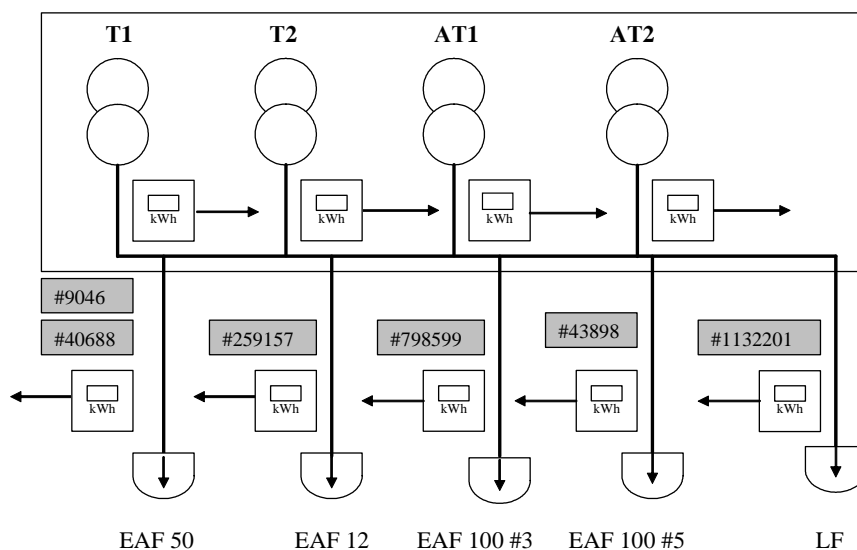

Figure 4. Electricity metering system at EAFs and LF

Subproject 4. Modernization of press equipment.

Serving motors of the press pump station are powered from the 6kV line. Substation 110/6 kV has two transformers. Each transformer has a commercial electricity meter. There are some addition consumers on the 6kV line. The performance of the meters is checked using the following formulae:

$$\Sigma(Tp1+Tp2) - \Sigma(Consumers+Pump Station) \leq 1.5\%$$

If the difference is more than 1.5%, verification of meters is performed. Defective meters being substituted within one day.

All data concerning electricity consumption is transmitted to the control and monitoring computer system. The press has a special registry log book, where working time of press is logged, among other data. The following figure presents electricity supplying system of the press with metering points.

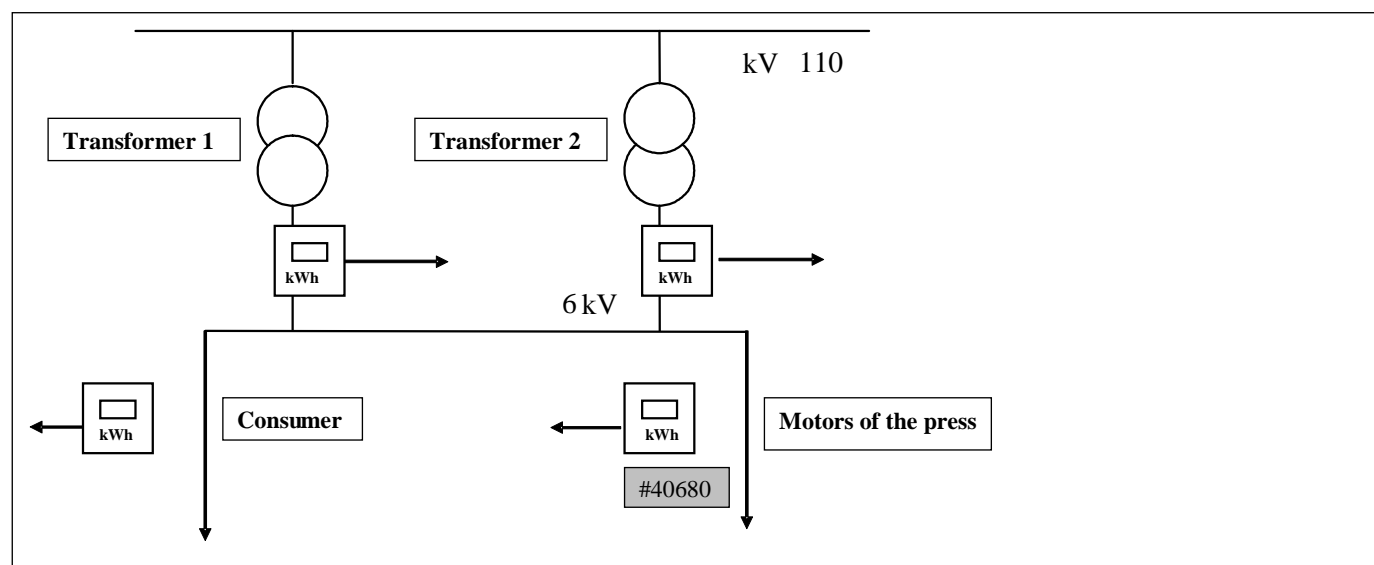

Figure 5. Electricity metering system at press

The control and monitoring system can be divided into an electrical part, a gas part, and steel weight part.

Electrical measurements

For the purpose of monitoring the emission reductions the following parameters are measured:

- Electricity consumption at EAFs;
- Electricity consumption at LF;
- Electricity consumption at VD;
- Electricity consumption at press' pump station.

Natural gas measurements

For the purpose of monitoring the emission reductions the following parameters are measured:

- Natural gas consumption, temperature and pressure at 22 reconstructed heating and thermal furnaces.

Steel weight measurement

For the purpose of monitoring the emission reductions the following parameters are measured:

- Weight of steel proceeded through the LF;
- Weight of steel proceeded through the VD;
- Weight of half-finished products proceeded through reconstructed heating and thermal furnaces.

B.1. Monitoring equipment types

1. Electricity meters “Energia -9”
2. Electricity meters “SA ZU-I670M”
3. Electricity meters “EuroAlfa”
4. Natural gas flow meters “IRVIS - K - 300”
5. Natural gas flow meter “Kromeschroder”
6. Natural gas flow meter “ABB”
7. Natural gas flow meter “Ergomera-126”
8. Natural gas flow meter “Metran 100DD”
9. Natural gas temperature meters “TSMU 274-05”
10. Natural gas temperature meters “TSPU - 205”
11. Natural gas temperature meters “TSMT -103 ”
12. Natural gas pressure meters “Metran 100 DI”
13. Natural gas pressure meter “Metran 55Ex Da”
14. Natural gas pressure meters “Metran 100 DA”
15. Logger-evaluators “Ergomera-126”
16. Weighing machine “ErMack-Vk1rk-10”

17. Weighing machine “ErMack-Vk1rk-20”
18. Weighing machine “ErMack-Vk1rk-50”
19. Weighing machine “ErMack-Vk1rk-80”
20. Weighing machine “02VPT-200MC”

B.1.2. Table providing information on the equipment used (incl. manufacturer, type, serial number, date of installation, date of last calibration, information to specific uncertainty, need for changes and replacements):

The control and monitoring system can be divided into an electrical part, a natural gas part and a steel weight part.

Electrical measurements

For the purpose of monitoring the emission reductions the following parameters are measured:

- Electricity consumption at EAFs;
- Electricity consumption at LF;
- Electricity consumption at VD;
- Electricity consumption at press’ pump station.

ID of the meter	Measuring parameter	Work parameter	Type	Serial number	Level of accuracy	Date of installation	Electricity consumed 1.10.2010-31.12.2010	Date of last calibration	Date of next calibration.
EL1	Electricity consumption at EAF50	MWh	Energia 9	40688	0.2%	2009	231.274	01.07.2007	01.07.2013
EL2	Electricity consumption at EAF100 #3 ³	kWh	SA ZU-I670M	798599	2%	2003	94.023	14.01.2008	14.01.2012
EL3	Electricity consumption at EAF100 #5	kWh	Energia 9	43898	0.2%	10.08.2008	182.074	31.01.2008	30.01.2014
EL4	Electricity consumption at LF ⁴	kWh	EuroAlpha	1132201	0.5%	2007	0	25.09.2006	25.09.2012
EL5	Electricity consumption at VD	kWh	Energia 9	44701	0.2%	2008	269.811	28.02.2008	28.02.2014
EL6	Electricity consumption at VD	kWh	Energia 9	44702	0.2%	2008	0.032	28.02.2008	28.02.2014
EL7	Electricity consumption at VD	kWh	Energia 9	44705	0.2%	2008	195.189	28.02.2008	28.02.2014
EL8	Electricity consumption at VD	kWh	Energia 9	44706	0.2%	2008	0.079	28.02.2008	28.02.2014
EL9	Electricity consumption at press	kWh	Energia 9	40680	0.2%	26.08.2008	697.09	09.2006	09.2012

³ For more details see Section B.4 “Special Event Log”

⁴ For more details see Section B.4 “Special Event Log”

JI MONITORING REPORT

“Improvement of the Energy efficiency at Energomashspetsstal (EMSS), Kramatorsk, Ukraine”

page 13

Table 2: List of electric meters

Electric current provided to the EAFs and LF have so high parameters (more than 5A), that they cannot be measured directly. The current parameters decreased through the transformers and measured. The following table presents list of transformers used in the electric current measuring.

ID of transformer	Transforming parameter	Work parameter	Type	Serial number	Level of accuracy	Transformation factor	Date of last calibration	Date of next calibration
TR1	Current at EAF50	A	TPOL-35	11	0.5%	600/5	13.05.2009	13.05.2013
TR2	Current at EAF50	A	TPOL-35	37	0.5%	600/5	13.05.2009	13.05.2013
TR3	Voltage at EAF50	V	ZNOM-35	1138121	0.5%	35000/100	13.05.2009	13.05.2013
TR4	Voltage at EAF50	V	ZNOM-35	1138211	0.5%	35000/100	13.05.2009	13.05.2013
TR5	Voltage at EAF50	V	ZNOM-35	1120877	0.5%	35000/100	13.05.2009	13.05.2013
TR6	Current at EAF100 #3	A	TPOL-35	113	0.5%	600/5	13.05.2009	13.05.2013
TR7	Current at EAF100 #3	A	TPOL-35	13	0.5%	600/5	13.05.2009	13.05.2013
TR8	Voltage at EAF100 #3	V	ZNOM-35	854859	0.5%	35000/100	13.05.2009	13.05.2013
TR9	Voltage at EAF100 #3	V	ZNOM-35	854965	0.5%	35000/100	13.05.2009	13.05.2013
TR10	Voltage at EAF100 #3	V	ZNOM-35	849517	0.5%	35000/100	13.05.2009	13.05.2013
TR11	Current at EAF100 #5	A	TPOL-35	351	0.5%	1000/5	13.05.2009	13.05.2013
TR12	Current at EAF100 #5	A	TPOL-35	458	0.5%	1000/5	13.05.2009	13.05.2013
TR13	Voltage at EAF100 #5	V	ZNOM-35	1284276	0.5%	35000/100	13.05.2009	13.05.2013
TR14	Voltage at EAF100 #5	V	ZNOM-35	1355405	0.5%	35000/100	13.05.2009	13.05.2013
TR15	Voltage at EAF100 #5	V	ZNOM-35	1213200	0.5%	35000/100	13.05.2009	13.05.2013
TR16	Current at LF	A	TPU 7051	5105040894	0.5%	500/5	13.05.2009	13.05.2013
TR17	Current at LF	A	TPU 7051	5105040895	0.5%	500/5	13.05.2009	13.05.2013
TR18	Current at LF	A	TPU 7051	5105040896	0.5%	500/5	13.05.2009	13.05.2013
TR19	Voltage at LF	V	ZNOM-35	1168572	0.5%	35000/100	13.05.2009	13.05.2013
TR20	Voltage at LF	V	ZNOM-35	1427592	0.5%	35000/100	13.05.2009	13.05.2013
TR21	Voltage at LF	V	ZNOM-35	1279988	0.5%	35000/100	13.05.2009	13.05.2013
TR22	Current at VD	A	T-0.66-1	21387	0.5%	600/5	13.05.2009	13.05.2013
TR23	Current at VD	A	T-0.66-1	19132	0.5%	600/5	13.05.2009	13.05.2013
TR24	Current at VD	A	T-0.66-1	21526	0.5%	600/5	13.05.2009	13.05.2013
TR25	Current at VD	A	T-0.66-1	83614	0.5%	600/5	13.05.2009	13.05.2013
TR26	Current at VD	A	T-0.66-1	21837	0.5%	600/5	13.05.2009	13.05.2013
TR27	Current at VD	A	T-0.66-1	19100	0.5%	600/5	13.05.2009	13.05.2013
TR28	Current at VD	A	T-0.66-1	19687	0.5%	600/5	13.05.2009	13.05.2013

JI MONITORING REPORT

“Improvement of the Energy efficiency at Energomashspetsstal (EMSS), Kramatorsk, Ukraine”

page 14

ID of transformer	Transforming parameter	Work parameter	Type	Serial number	Level of accuracy	Transformation factor	Date of last calibration	Date of next calibration
TR29	Current at VD	A	T-0.66-1	21888	0.5%	600/5	13.05.2009	13.05.2013
TR30	Current at press	A	TLK-10	3051	0.5%	1500/5	13.05.2009	13.05.2013
TR31	Current at press	A	TLK-10	3102	0.5%	6000/100	13.05.2009	13.05.2013

Table 3: List of transformers

JI MONITORING REPORT

“Improvement of the Energy efficiency at Energomashspetsstal (EMSS), Kramatorsk, Ukraine”

page 15

Natural gas measurements

For the purpose of monitoring the emission reductions the following parameters are measured:

- Natural gas consumption at 22 reconstructed heating and thermal furnaces.

ID of meter	Measuring parameter	Work parameter	Type	Serial number	Level of accuracy	Date of installation	NG consumed 1.10.2010-31.12.2010	Date of last calibration	Date of next calibration
NG1	Consumption of the NG at thermal furnace #1, TS	m ³	IRVIS - K - 300	5274	1%	01.2007	173580	02.03.2010	02.03.2012
NG2	Consumption of the NG at thermal furnace #2, TS	m ³	IRVIS - K - 300	5275	1%	01.2007	178197	03.03.2010	03.03.2012
NG3	Consumption of the NG at thermal furnace #9, TS	m ³	IRVIS - K - 300	5182	1%	01.2006	131086	04.03.2010	04.03.2012
NG4	Consumption of the NG at thermal furnace #10, TS	m ³	IRVIS - K - 300	5183	1%	01.2006	130139	02.03.2010	02.03.2012
NG5	Consumption of the NG at heating furnace #7, FPS	m ³	IRVIS - K - 300	5740	1%	10.2008	558811	03.02.2010	03.02.2012
NG6	Consumption of the NG at heating furnace #8, FPS	m ³	IRVIS - K - 300	5480	1%	12.2007	504131	20.02.2009	20.02.2011
NG7	Consumption of the NG at heating furnace #9, FPS	m ³	IRVIS - K - 300	5482	1%	12.2007	366011	20.02.2009	20.02.2011
NG8	Consumption of the NG at heating furnace #10, FPS	m ³	IRVIS - K - 300	5483	1%	12.2007	498047	20.02.2009	20.02.2011
NG9	Consumption of the NG at thermal furnace #30, FPS	m ³	IRVIS - K - 300	5711	1%	05.2007	320737	16.10.2009	16.10.2011
NG10	Consumption of the NG at thermal furnace #18, FPS	m ³	Kromschroder DM 650 Z150-40	98107	1.5%	03.2008	155467	23.03.2010	23.03.2012
NG11	Consumption of the NG at thermal furnace #19, FPS	m ³	Kromschroder DM 650 Z150-40	69191748	1.5%	05.2009	240570	08.05.2009	08.05.2011
NG12	Consumption of the NG at thermal furnace #20, FPS	m ³	Kromschroder DM 650 Z150-40	69193831	1.5%	05.2009	243322	08.05.2009	08.05.2011
NG13	Consumption of the NG at thermal furnace #21, FPS	m ³	Kromschroder DM 650 Z150-40	69193830	1%	09.2009	193160	15.07.2009	15.07.2011
NG14	Consumption of the NG at thermal furnace #32, FPS	m ³	Kromschroder DM 650 Z150-40	69191749	1%	09.2009	196724	15.07.2009	15.07.2011
NG15	Consumption of the NG at heating furnace #33, FPS	Nm ³	ABB FMT500-IG	28751947	1%	08.2009	224379	12.08.2009	12.08.2011
NG16	Consumption of the NG at thermal furnace #37, FPS	m ³	Kromschroder DM 650 Z150-40	69196330	1 %	09.2009	47609	29.04.2010	29.04.2012
NG17	Consumption of the NG at thermal furnace #4, TS	m ³	Kromschroder DM 650 Z150-40	10512270	1 %	11.2009	120426	02.09.2010	02.09.2012
NG18	Consumption of the NG at heating furnace #34, FPS	Nm ³	ABB FMT500-IG	28751945	1%	01.2009	204177	21.08.2009	21.08.2011
NG19	Consumption of the NG at heating furnace #35, FPS	Nm ³	ABB FMT500-IG	28751946	1%	01.2009	222623	21.08.2009	21.08.2011

JI MONITORING REPORT

“Improvement of the Energy efficiency at Energomashspetsstal (EMSS), Kramatorsk, Ukraine”

page 16

ID of meter	Measuring parameter	Work parameter	Type	Serial number	Level of accuracy	Date of installation	NG consumed 1.10.2010-31.12.2010	Date of last calibration	Date of next calibration
NG20	Consumption of the NG at heating furnace #36, FPS	m ³	Metran 100DD	462213	0.5%	01.2010	161966	30.09.2010	30.09.2011
NG21	Consumption of the NG at thermal furnace #38, FPS	m ³	Kromschroder DM 650 Z150-40	69199960	1 %	06.2010	36133	01.09.2010	01.09.2011
NG22	Consumption of the NG at thermal furnace #1, FPS	m ³	IRVIS – PC4	13398	1%	01.08.2010	192869	03.06.2010	03.06.2012

Table 4: List of natural gas meters

Natural gas meters measuring gas flow in the m³. To convert measuring value to Nm³, temperature and pressure meters are used. The following tables present temperature and pressure meters.

ID of meter	Measuring parameter	Work parameter	Type	Serial number	Level of accuracy	Date of installation	Date of last calibration	Date of next calibration
TP1	Temperature of the NG at thermal furnace #1, TS	C°	TSMU 274-05	655358	0.5%	09.2008	07.09.2010	07.09.2011
TP2	Temperature of the NG at thermal furnace #2, TS	C°	TSMU 274-05	655355	0.5%	09.2008	07.09.2010	07.09.2011
TP3	Temperature of the NG at thermal furnace #9, TS	C°	TSMU 274-05	655359	0.5%	09.2008	12.07.2010	12.07.2011
TP4	Temperature of the NG at thermal furnace #10, TS	C°	TSMU 274-05	655363	0.5%	09.2008	14.07.2010	14.07.2011
TP5	Temperature of the NG at heating furnace #7, FPS	C°	TSMU 274-05	655354	0.5%	09.2008	08.07.2010	08.07.2011
TP6	Temperature of the NG at heating furnace #8, FPS	C°	TSMU 274-05	655362	0.5%	09.2008	14.07.2010	14.07.2011
TP7	Temperature of the NG at heating furnace #9, FPS	C°	TSPU - 205	8360	0.008t	09.2008	21.09.2010	21.09.2011
TP8	Temperature of the NG at heating furnace #10, FPS	C°	TSPU - 205	8362	0.008t	09.2008	27.09.2010	27.09.2011
TP9	Temperature of the NG at thermal furnace #30, FPS	C°	TSPU - 205	8365	0.008t	09.2008	21.09.2010	21.09.2011
TP10	Temperature of the NG at thermal furnace #18, FPS	C°	TCMU – 274-05	655360	0.008t	07.2008	13.07.2010	13.07.2011
TP11	Temperature of the NG at thermal furnace #19, FPS	C°	TCMU – 205	6000	0.008t	05.2009	06.05.2010	06.05.2011
TP12	Temperature of the NG at thermal furnace #20, FPS	C°	TCMU – 205	6011	0.008t	05.2009	06.05.2010	06.05.2011
TP13	Temperature of the NG at thermal furnace #21, FPS	C°	TSPU - 205	655361	0.008t	09.2009	15.09.2010	15.09.2011
TP14	Temperature of the NG at thermal furnace #32, FPS	C°	TCMU – 274	655356	0.008t	09.2009	13.07.2010	13.07.2011
TP15	Temperature of the NG at thermal furnace #37, FPS	C°	TCMU – 274	750917	0.008t	09.2009	14.07.2010	14.07.2011

JI MONITORING REPORT

“Improvement of the Energy efficiency at Energomashspetsstal (EMSS), Kramatorsk, Ukraine”

page 17

TP16	Temperature of the NG at thermal furnace #4, TS	C°	TCMU – 274-05	750977	0.25%	11.2009	16.07.2010	16.07.2011
TP17	Temperature of the NG at heating furnace #36, FPS	C°	TCMT – 103	195.447	0.25%	02.2010	16.02.2010	16.02.2011
TP18	Temperature of the NG at thermal furnace #38, FPS	C°	TCMT – 103	195.435	0.25%	06.2010	16.02.2010	16.02.2011
TP19	Temperature of the NG at thermal furnace #35, FPS	C°	TCMT – 103	195.443	0.25%	02.2010	16.02.2010	16.02.2011

Table 5: List of temperature meters

JI MONITORING REPORT

“Improvement of the Energy efficiency at Energomashspetsstal (EMSS), Kramatorsk, Ukraine”

page 18

ID of meter	Measuring parameter	Work parameter	Type	Serial number	Level of accuracy	Date of installation	Date of last calibration	Date of next calibration
PR1	Pressure of the NG at thermal furnace #1, TS	kPa	Metran 100 DI	274538	0.5%	01.2007	24.11.2010	24.11.2011
PR2	Pressure of the NG at thermal furnace #2, TS	kPa	Metran 100 DI	275890	0.5%	01.2007	02.12.2010	02.12.2011
PR3	Pressure of the NG at thermal furnace #9, TS	kPa	Metran 100 DI	241764	0.5%	01.2006	17.05.2010	17.05.2011
PR4	Pressure of the NG at thermal furnace #10, TS	kPa	Metran 100 DI	241763	0.5%	01.2006	30.08.2010	30.08.2011
PR5	Pressure of the NG at heating furnace #7, FPS	kPa	Metran 100 DI	422353	0.5%	10.2008	08.07.2010	08.07.2011
PR6	Pressure of the NG at heating furnace #8, FPS	kPa	Metran 100 DI	376707	0.5%	12.2007	04.03.2010	04.03.2011
PR7	Pressure of the NG at heating furnace #9, FPS	kPa	Metran 100 DI	000088	0.5%	12.2007	23.03.2010	23.03.2011
PR8	Pressure of the NG at heating furnace #10, FPS	kPa	Metran 100 DI	000087	0.5%	12.2007	04.02.2010	04.02.2011
PR9	Pressure of the NG at thermal furnace #30, FPS	kPa	Metran 100 DI	387352	0.5%	05.2007	16.02.2010	16.02.2011
PR10	Pressure of the NG at thermal furnace #18, FPS	kPa	Metran 55 Ex DA	461211	0.25%	05.2008	13.05.2010	13.05.2011
PR11	Pressure of the NG at thermal furnace #19, FPS	kPa	Metran 55 Ex DA	486509	0.25%	05.2009	13.05.2010	13.05.2011
PR12	Pressure of the NG at thermal furnace #20, FPS	kPa	Metran 55 Ex DA	486786	0.25%	05.2009	14.05.2010	14.05.2011
PR13	Pressure of the NG at thermal furnace #21, FPS	kPa	Metran 55 DA	458976	0.5%	09.2009	14.05.2010	14.05.2011
PR14	Pressure of the NG at thermal furnace #32, FPS	kPa	Metran 55 DA	486510	0.5%	09.2009	14.05.2010	14.05.2011
PR15	Pressure of the NG at thermal furnace #37, FPS	kPa	Metran 55 Ex DA	461217	0.25%	09.2009	14.07.2010	14.07.2011
PR16	Pressure of the NG at thermal furnace #4, TS	kPa	Metran 100 DA	340571	0.5%	11.2009	22.01.2010	22.01.2011
PR17	Pressure of the NG at heating furnace #36, FPS	kPa	Metran 100 DA	442214	0.5%	01.2010	07.10.2010	07.10.2011
PR18	Pressure of the NG at thermal furnace #38, FPS	kPa	Metran 55 DA	458977	0.5%	06.2010	08.10.2010	08.10.2011
PR19	Pressure of the NG at heating furnace #35, FPS	kPa	Metran 100 DA	442216	0.5%	01.2010	04.10.2010	04.10.2011

Table 6: List of pressure meters

Steel weight measurement

For the purpose of monitoring the emission reductions the following parameters are measured:

- Weight of steel proceeded in the Electro Steel Melting Workshop;
- Weight of half-finished products proceeded through reconstructed heating and thermal furnaces.

JI MONITORING REPORT

“Improvement of the Energy efficiency at Energomashspetsstal (EMSS), Kramatorsk, Ukraine”

page 19

ID of weighing machine	Measuring parameter	Work parameter	Type	Serial number	level of accuracy	Date of installation	Date of last calibration	Date of next calibration
WM1	Weight of half-finished products of FPS	t	ErMack-Vk1rk-10	0115047	6kg	2005	01.07.2010	01.07.2011
WM2	Weight of half-finished products of TS	t	ErMack-Vk1rk-20	205122	15kg	2005	19.03.2010	19.03.2011
WM3	Weight of half-finished products of TS	t	ErMack-Vk1rk-50	506149	60kg	2006	03.06.2010	03.06.2011
WM4	Weight of half-finished products of FPS	t	ErMack-Vk1rk-80	806148	150kg	2006	03.06.2010	03.06.2011
WM5	Weight of steel melted at LF	t	01VKT-200M	222	2kg	2007	11.11.2010	11.11.2011

Table 7: List of weighting machines

The following table presents list of logger-evaluators.

ID of meter	Measuring parameter	Work parameter	Type	Serial number	Level of accuracy	Date of installation	Date of last calibration	Date of next calibration
LE1	Logging of NG consumption at thermal furnace #4, TS	Nm ³	Ergomera-126	838	0.1%	01.2010	13.08.2009	13.08.2011
LE2	Logging of NG consumption at heating furnace #35, 36, FPS	Nm ³	Ergomera-126	836	0.1%	01.2010	13.08.2009	13.08.2011
LE3	Logging of NG consumption at thermal furnace #37, FPS	Nm ³	Ergomera-126	800	0.1%	01.2010	13.08.2009	13.08.2011
LE4	Logging of NG consumption at thermal furnace #38, FPS	Nm ³	Ergomera-126	834	0.1%	06.2010	13.08.2009	13.08.2011

B.1.3. Calibration procedures

For Electricity Meters:

QA/QC procedures	Body responsible for calibration and certification
-------------------------	---

JI MONITORING REPORT

“Improvement of the Energy efficiency at Energomashspetsstal (EMSS), Kramatorsk, Ukraine”

page 20

Calibration interval of such meters is 4 years for the meters produced before 01.01.1988 and 6 years for the meters produced after 01.01.1988.	Ukrainian Centre for Standardization and Metrology
--	--

For Natural Gas Meters

QA/QC procedures	Body responsible for calibration and certification
Calibration interval of such meters is 2 years.	Ukrainian Centre for Standardization and Metrology

For temperature meters

QA/QC procedures	Body responsible for calibration and certification
Calibration interval of such meters is 1 year.	Ukrainian Centre for Standardization and Metrology

For pressure meters

QA/QC procedures	Body responsible for calibration and certification
Calibration interval of such meters is 1 year.	Ukrainian Centre for Standardization and Metrology

For weighting machines:

QA/QC procedures	Body responsible for calibration and certification
Calibration interval of such meters is 1 year.	Ukrainian Centre for Standardization and Metrology

For transformers:

QA/QC procedures	Body responsible for calibration and certification
Calibration interval of such meters is 4 years.	Ukrainian Centre for Standardization and Metrology

For loggers-evaluators:

QA/QC procedures	Body responsible for calibration and certification

Calibration interval of such meters is 2 years.

Ukrainian Centre for Standardization and Metrology

B.1.4. Involvement of Third Parties:

Ukrainian Centre for Standardization and Metrology.

B.2. Data collection (accumulated data for the whole monitoring period):

The operational and management structure of the project see PDD, *Flowchart D.3.1: Responsibilities within the monitoring team.*

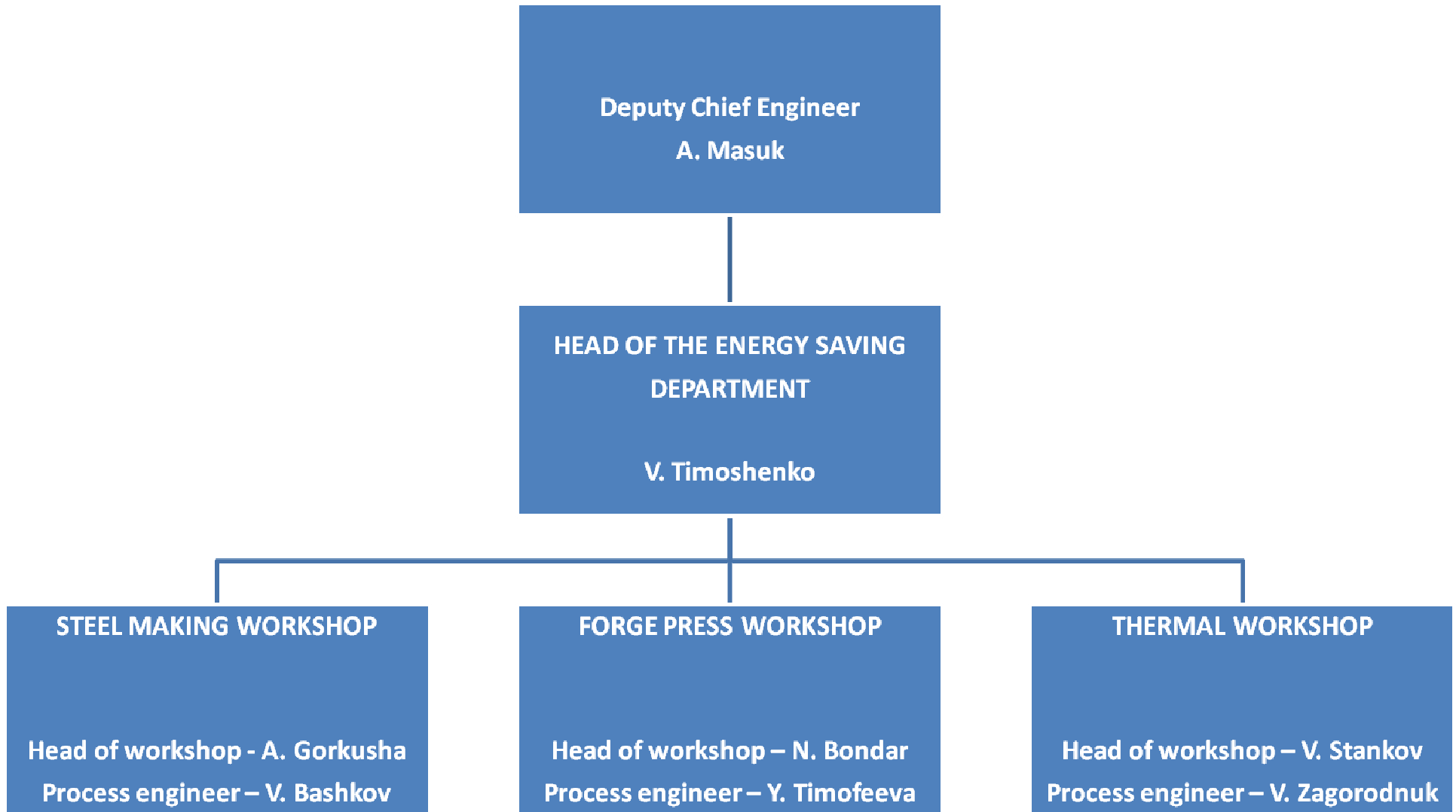

Figure 6. The operational and management structure

B.2.1. List of fixed default values and ex-ante baseline factors:

Data variable	Source of data	Data unit	Comment
EF_{NG} , emission factor of the NG burning process	IPCC 2006	tCO ₂ /MWh	IPCC 2006 default value = 0.0561 tCO ₂ /GJ.
$EF_{el,y}$, emission factor of the Ukrainian grid for reducing project	See Annex 4 of PDD	tCO ₂ /MWh	= 0.896 tCO ₂ /MWh

Table 8: Project fixed default values

Data variable	Source of data	Data unit	Comment
EF_{Coal} , emission factor for local (anthracite) coal burning	IPCC 2006	tCO ₂ /MWh	IPCC 2006 default value = 0.0983 tCO ₂ /GJ
$EF_{el,y}$, emission factor of the Ukrainian grid for reducing project	See Annex 4	tCO ₂ /MWh	= 0.896 tCO ₂ /MWh

Table 9: Baseline fixed default values

Data variable	Source of data	Data unit	Comment
$SPNG_{if}$, the baseline ex-ante specific NG consumption of the 26 reconstructed furnaces	Baseline information	1000nm ³ /t steel	See PDD, Table A2.1 for more detailed information
SPH_{VD} , the baseline ex ante specific heat consumption of the old VD	Baseline three years information	MWh/t	See PDD, Table A2.2 for more detailed information
$SPEL_{VD}$, baseline ex ante specific electrical consumption of the old VD	Baseline information	MWh/t	=0.000028 MWh/t steel
$SPEL_{ES}$, baseline ex ante specific consumption of electricity per tone of electro steel	Baseline three years information	MWh/t	See PDD, Table A2.3 for more detailed information
EL_{MOT} , installed capacity of the press' serving motors before reconstruction	Project design documentation	MW	It was 24 motors, 500kW each. So, EL_{MOT} =12MW

Table 10: Baseline ex-ante factors

B.2.2. List of variables:

The list of variables was defined in the PDD (Section D) in order to calculate ERs in a proper way. Some of variables could not be monitored directly, so data from the meters should be adjusted by appointed correction factors. The following table establishes the link between data from the meters and corresponding variables.

Data variable	Data unit	Method of calculation	Meters used for calculation
EL_{VD} , electricity consumed by the new vacuum system (VD)	MWh	$EL_{VD} = \frac{EL \times K_{TR}}{1000},$ <p>Where: EL = electricity consumption, monitored at VD, kWh; KTR = 600/5 transformation factor, (see Table 4, TR22,...,TR29).</p>	EL= (EL5+EL6+EL7+EL8) (see Table 3)
EL_{LF} , Electricity consumed by the ladle furnace	MWh	$EL_{LF} = \frac{EL \times K_{TR,current} \times K_{TR,voltage}}{1000},$ <p>Where: EL = electricity consumption, monitored at LF, kWh; K_{TR,current} = 500/5, transformation factor of current transformer, (see Table 4, TR16, TR17, TR18); K_{TR,voltage} = 35000/100, transformation factor of voltage transformer, (see Table 4, TR19, TR20, TR21);</p>	EL=EL4 (see Table 3)
EL_{EAF} , Electricity consumed by the EAFs	MWh	$EL_{EAF} = EL_{EAF50} + EL_{EAF100\#3} + EL_{EAF100\#5},$ <p>With</p> $EL_{EAF100\#3} = \frac{EL_{100\#3} \times K_{TR100\#3,current} \times K_{TR100\#3,voltage}}{1000},$ $EL_{EAF100\#5} = \frac{EL_{100\#5} \times K_{TR100\#5,current} \times K_{TR100\#5,voltage}}{1000},$ <p>Where: EL_{EAF50} = electricity consumption, monitored at EAF50, MWh; EL_{EAF100#3} = electricity consumption, monitored at EAF100#3, kWh; K_{TR100#3,current} = 600/5, transformation factor of current transformer, (see Table 4, TR6,</p>	EL _{EAF50} = EL1 (see Table 3) EL _{EAF100#3} = EL2 (see Table 3) EL _{EAF100#5} = EL3 (see Table 3)

		TR7); $K_{TR100\#3,voltage} = 35000/100$, transformation factor of voltage transformer, (see Table 4, TR8, TR9, TR10); $EL_{EAF100\#5}$ = electricity consumption, monitored at EAF100#3, kWh; $K_{TR100\#5,current} = 600/5$, transformation factor of current transformer, (see Table 4, TR11, TR12); $K_{TR100\#5,voltage} = 35000/100$, transformation factor of voltage transformer, (see Table 4, TR13, TR14, TR15);	
EL_{PR} , electricity consumed by the new pumps of the 15,000 tonnes press	MWh	$EL_{PR} = \frac{EL \times K_{TR,current} \times K_{TR,voltage}}{1000}$ <p>Where: EL = electricity consumption, monitored at press, kWh; $K_{TR,current} = 1500/5$, transformation factor of current transformer, (see Table 4, TR30); $K_{TR,voltage} = 6000/100$, transformation factor of voltage transformer, (see Table 4, TR31).</p>	EL = EL9 (see Table 3)

Table 11: Project variables

Baseline emissions variables to be measured:

Data variable	Source of data	Data unit	Method of calculation	Meters used for calculation
$PRST_{if}$, the production level of each of the 26 reconstructed thermal and heating furnaces	Measuring devices of the thermal shop and forge and press shop	Tonnes	$PRST_{if}$ is a result of direct measurement (weighing) of the of half-finished products proceeded through each furnace	WM1-WM4
$PRVS_{VD}$, the production volume of vacuumed steel	Measuring devices of the VD	Tonnes	$PRVS_{VD}$ is a result of direct measurement (weighing) of the steel proceeded through VD	WM5
$PRES$, the production volume of electro steel	Measuring devices of the electro steel shop	Tonnes	$PRES$ is a result of direct measurement (weighing) of the steel proceeded through LF	WM5
T_{pp} , working hours of press	Server at energy saving department	hours	T_{pp} is the sum from registry log book records	Registry log-book on press

Table 12: Baseline measurable variables

B.2.3. Data concerning GHG emissions by sources of the project activity:

Variable	Description	Unit	Value
$NG_{if,y,1}$	Natural gas consumption at thermal furnace #9,TS	1000Nm ³	131.086
$NG_{if,y,2}$	Natural gas consumption at thermal furnace #10,TS	1000Nm ³	130.139
$NG_{if,y,3}$	Natural gas consumption at thermal furnace #1,TS	1000Nm ³	173.580
$NG_{if,y,4}$	Natural gas consumption at thermal furnace #2,TS	1000Nm ³	178.197
$NG_{if,y,5}$	Natural gas consumption at heating furnace #10,FPS	1000Nm ³	498.047
$NG_{if,y,6}$	Natural gas consumption at heating furnace #9,FPS	1000Nm ³	366.011
$NG_{if,y,7}$	Natural gas consumption at heating furnace #8,FPS	1000Nm ³	504.131
$NG_{if,y,8}$	Natural gas consumption at heating furnace #7,FPS	1000Nm ³	558.811
$NG_{if,y,9}$	Natural gas consumption at thermal furnace #30,FPS	1000Nm ³	320.737
$NG_{if,y,10}$	Natural gas consumption at thermal furnace #18,FPS	1000Nm ³	155467
$NG_{if,y,11}$	Natural gas consumption at thermal furnace #19,FPS	1000Nm ³	240.570
$NG_{if,y,12}$	Natural gas consumption at thermal furnace #20,FPS	1000Nm ³	243.322
$NG_{if,y,13}$	Natural gas consumption at thermal furnace #21,FPS	1000Nm ³	193.160
$NG_{if,y,14}$	Natural gas consumption at thermal furnace #32,FPS	1000Nm ³	196.724
$NG_{if,y,15}$	Natural gas consumption at heating furnace #33,FPS	1000Nm ³	224.379
$NG_{if,y,16}$	Natural gas consumption at thermal furnace #37,FPS	1000Nm ³	47.609
$NG_{if,y,17}$	Natural gas consumption at thermal furnace #4,TS	1000Nm ³	120.426
$NG_{if,y,18}$	Natural gas consumption at heating furnace #34,FPS	1000Nm ³	204.177
$NG_{if,y,19}$	Natural gas consumption at heating furnace #35,FPS	1000Nm ³	222.623
$NG_{if,y,20}$	Natural gas consumption at heating furnace #36,FPS	1000Nm ³	161.966
$NG_{if,y,21}$	Natural gas consumption at thermal furnace #38,FPS	1000Nm ³	36.133
$NG_{if,y,22}$	Natural gas consumption at heating furnace #1,FPS	1000Nm ³	192.869
EL_{VD}	Electricity consumption by new VD	MWh	45.518
EL_{LF}	Electricity consumption by LF	MWh	3771.59
EL_{EAF}	Electricity consumption by EAFs	MWh	19599.74
EL_{PR}	Electricity consumption by the new pumps of the press	MWh	697.09

Table 13: Data collected in the project scenario

B.2.4.Data concerning GHG emissions by sources of the baseline:

Variable	Description	Unit	Value
$PRST_{if,1}$	Half finish products production at thermal furnace #9,TS	Tonnes	944.713
$PRST_{if,2}$	Half finish products production at thermal furnace #10,TS	Tonnes	622.398
$PRST_{if,3}$	Half finish products production at thermal furnace #1,TS	Tonnes	883.43
$PRST_{if,4}$	Half finish products production at thermal furnace #2,TS	Tonnes	1235.2
$PRST_{if,5}$	Half finish products production at heating furnace #10,FPS	Tonnes	3884.81
$PRST_{if,6}$	Half finish products production at heating furnace #9,FPS	Tonnes	4467.41
$PRST_{if,7}$	Half finish products production at heating furnace #8,FPS	Tonnes	4550.9
$PRST_{if,8}$	Half finish products production at heating furnace #7,FPS	Tonnes	5071.2
$PRST_{if,9}$	Half finish products production at thermal furnace #30,FPS	Tonnes	1424.67
$PRST_{if,10}$	Half finish products production at thermal furnace #18,FPS	Tonnes	1641.88
$PRST_{if,11}$	Half finish products production at thermal furnace #19,FPS	Tonnes	1527.82
$PRST_{if,12}$	Half finish products production at thermal furnace #20,FPS	Tonnes	1619.51
$PRST_{if,13}$	Half finish products production at thermal furnace #21,FPS	Tonnes	1419.28
$PRST_{if,14}$	Half finish products production at thermal furnace #32,FPS	Tonnes	1166.74
$PRST_{if,15}$	Half finish products production at heating furnace #33,FPS	Tonnes	2243.89
$PRST_{if,16}$	Half finish products production at thermal furnace #37,FPS	Tonnes	499.04
$PRST_{if,17}$	Half finish products production at thermal furnace #4,TS	Tonnes	1012.35
$PRST_{if,18}$	Half finish products production at heating furnace #34,FPS	Tonnes	2370.39
$PRST_{if,19}$	Half finish products production at heating furnace #35,FPS	Tonnes	2347.15
$PRST_{if,20}$	Half finish products production at heating furnace #36,FPS	Tonnes	1671.85
$PRST_{if,21}$	Half finish products production at thermal furnace #38,FPS	Tonnes	260.62
$PRST_{if,22}$	Half finished products production at heating furnace	Tonnes	1623.93

Variable	Description	Unit	Value
	#1,FPS		
$PRVS_{VD}$	Vacuumed steel production at VD	Tonnes	23959
$EBDHC$	efficiency of the steam boilers at the DHC	%	82.4
$PRES$	Steel production at LF	Tonnes	27 235.38
T_{PP}	Working time of the motors on press	Hours	1232.67

Table 14: Data collected in the baseline scenario

B.2.5.Data concerning leakage:

PDD did not identify any leakages therefore this section is not applicable.

B.2.6.Data concerning environmental impacts:

The project improved efficiency of use of natural gas, electricity and heat at the enterprise and thus led to decrease of harmful emissions.

B.3.Data processing and archiving (incl. software used):

Subproject 1. Reconstruction of thermal and heating furnaces. Information from flow meters, pressure and temperature sensors are transmitting to the control and monitoring computer system. All information about technological process is saved continuously. The archiving period for the log files is at least one year. Information that corresponds to the natural gas consumption in fourth quarter 2010 has been burned on CDs. These CDs are stored till the end of the crediting period plus two years.

Every half-finished product that process through the furnaces has its own unique certificate. This certificate reflects all operations performed on the product and the weight on the exit of every workshop. So, the weight of half-finished products that proceed through each furnace could be easily monitored. Information from the certificates is saved in the log books in order to simplify the monitoring process.

A report including natural gas consumption and weight of half finished products is generating on a monthly basis. The report is signed by the Head of Energy Saving Department, Head of corresponding workshop and approved by Chief Engineer.

Subproject 2. Installation of a new vacuum system. Information from the meters is passed to the control and monitoring computer system of vacuumator. A computer system records information about every vacuumation session, including melt passport, time and electricity consumption. The archiving period for the log files is at least one year. Information that corresponds to the electricity consumption in fourth quarter 2010 has been burned on CDs. These CDs are stored till the end of the crediting period plus two years.

Subproject 3. Installation of an arc ladle furnace. The data from electricity meters concerning electricity consumption is transmitted to the control and monitoring computer system continuously. The computer system records information about each melt process, including melt certificate. This certificate includes information about the number of the EAF where steel was melted, steel content, amount of electricity consumed during melting and weight of steel. The archiving period for the log files is at least one year. All melt certificates for the fourth quarter 2010 has been burned to CDs. These CDs are stored till the end of the crediting period plus two years.

Subproject 4. Modernization of press equipment.

All data concerning electricity consumption is transmitted to the control and monitoring computer system. The press has a special registry log book, where working time of press is logged, among other data. The following figure presents electricity supplying system of the press with metering points.

The overall data processing presents on the following figure

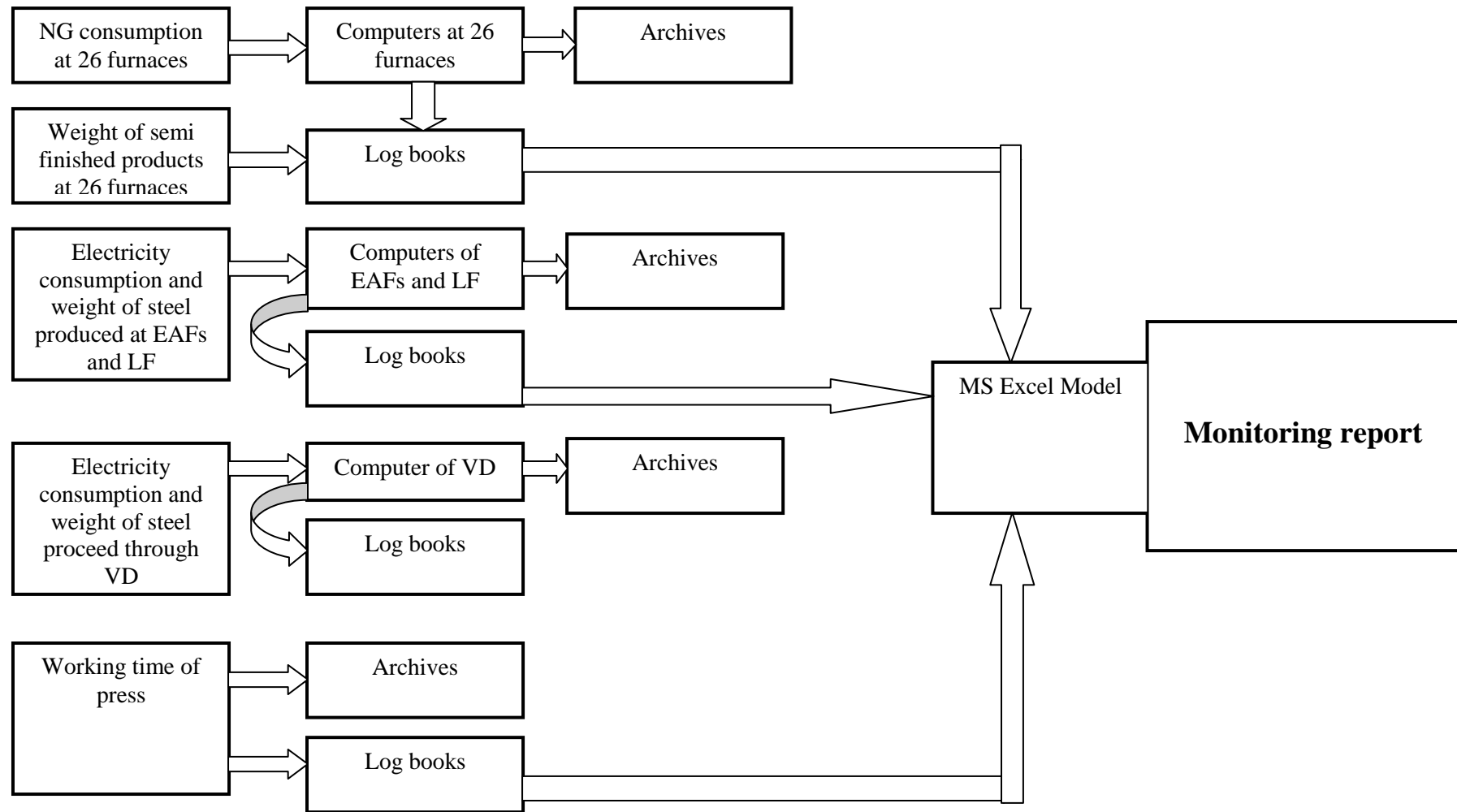

Figure 7: Data Processing Chart

B.4. Special event log:

Since 04 of February 2010, due to the Ladle Furnace’s transformer failure, feeding of the LF as well as metering of the electricity consumption was switched to the EAF100#3 transformer. All supporting documents have been submitted to the AIE during the previous site visit.

SECTION C. Quality assurance and quality control measures

C.1. Documented procedures and management plan:

C.1.1. Roles and responsibilities:

The general management of the monitoring team is implemented by the Deputy Chief Engineer of the EMSS through supervising and coordinating activities of his subordinates, such as the head of Energy Saving Department, the head of Steel Making Shop, Press-Forging Shop and Thermal Shop. On-site day-to-day (operational) management is implemented by the heads of corresponding shops. The technological process data is logged into the PCs continuously. The PCs at the reconstructed furnaces, LF, VD, etc., have not only monitoring but control functions. Keeping the PCs in a working condition is a responsibility of the Department of the automated control systems.

All data necessary for the CO₂ emission reductions calculation is collected in the Energy Saving Department. The head of the Energy Saving Department is making calculations on a monthly basis. The general supervision of the monitoring system is executed by the Deputy Chief Engineer.

For this monitoring period the names of the personnel involved is as follows:

- Deputy Chief Engineer: A. Masyuk
- Head of Energy Saving Department: V. Timoshenko
- Head of the Steel Making Shop: A. Gorkusha
- Head of the Press-Forging Shop: N. Bondar
- Head of the Thermal Shop: V. Stankov

C.1.2. Trainings:

All contracts for the equipment supplying include chapter describing personnel training. Training is providing by equipment producers.

C.2. Involvement of Third Parties:

The Ukrainian Centre for Standardization and Metrology is a Third Party involved.

C.3. Internal audits and control measures:

CO₂ emission reductions calculations are performing on the monthly basis by the head of the Energy Saving Department. All energy sources flows (such as electricity and natural gas) are logged on the server in the Energy Saving Department. Hence the head of Department checks the correctness of measurements by the indirect calculations.

C.4. Troubleshooting procedures:

Every day the Energy Saving Department reports to the Chief Engineer about energy resources consumption by EMSS. That report is the result of analyzing of the data logging on a dedicated server. In case of any meter failure, data discrepancy will be found within one day. The meter will be substituted by working one. CO₂ emissions reduction will be calculated by cross-checking method for the period of malfunctioning.

SECTION D. Calculation of GHG emission reductions

D.3.1. Project emissions:

The project emissions are calculated by the equation:

$$PE_y = \sum_{i=1}^{i=4} PE_{spi} ; \quad (Equation 1)$$

Where:

PE_y - are the project emissions for the monitoring period, [tCO₂];

PE_{spi} - are the project emissions from each subproject, from SP1 to SP4;

The project emissions [tCO₂/y] from SP1 are:

$$PE_{sp1} = \sum_{i=1}^{i=n} \left(\sum_{1}^{26} NG_{tf,i} * LCV_{NG,i} * EF_{NG} \right) ; \quad (Equation 2)$$

Where:

PE_{sp1} - is the sum of project emissions of subproject 1 from each month of the monitoring period , [tCO₂];

$NG_{tf,i}$ - is the volume of NG, used by the reconstructed furnaces in the month i, [1000 nm³];

$LCV_{NG,i}$ - is the lower calorific value of the NG for the month i, [MWh/1000nm³];

EF_{NG} - is the emission factor of the NG burning process, [tCO₂/MWh].

The project emissions [tCO₂/y] from SP2 are:

$$PE_{sp2} = \sum_{i=1}^n (EL_{VD,i} * EF_{el}); \quad (Equation 3)$$

Where:

PE_{sp2} - is the sum of project emissions of subproject 2 from each month of the monitoring period, [tCO₂];

$EL_{VD,i}$ - is the electrical consumption of the new VD in the month i, [MWh];

EF_{el} - is the calculated emission factor of the Ukrainian grid, [tCO₂/MWh].

The project emissions [tCO₂/y] from SP3 are:

$$PE_{sp3} = \sum_{i=1}^n ((EL_{LF,i} + EL_{EAF,i}) * EF_{el}); \quad (Equation 4)$$

Where:

PE_{sp3} - is the sum of project emissions of subproject 3 from each month of the monitoring period, [tCO₂];

$EL_{LF,i}$ - is the electrical consumption of the new ladle furnace in the month i, [MWh];

$EL_{EAF,i}$ - is the electrical consumption of the electric arc furnace in the month i, [MWh];

The project emissions [tCO₂/y] from SP4 are:

$$PE_{sp4} = \sum_{i=1}^n (EL_{PR,i} * EF_{el,y}); \quad (Equation 5)$$

Where:

PE_{sp4} - is the sum of project emissions of subproject 4 from each month of the monitoring period, [tCO₂];

$EL_{PR,i}$ - is the electrical consumption of the new pumps of the 15,000 tonnes press in the month i, [MWh].

4Q 2010	
Project emissions	[tCO₂e]
Subproject 1. Reconstruction of thermal and heating furnaces	9691
Subproject 2. Installation of a new vacuum system	41
Subproject 3. Installation of an arc ladle furnace	20941
Subproject 4. Modernization of press equipment	625
Total for third quarter of 2010	31297

Table 15: Project emissions

D.3.2. Baseline emissions:

$$BE_y = \sum_{i=1}^{i=4} BE_{spi}; \quad (Equation 6)$$

Where:

BE_y - are the baseline emissions for the monitoring period, [tCO₂];

BE_{spi} - are the baseline emissions from each subproject, from SP1 to SP4.

The baseline emissions for SP1 [tCO₂/y] are:

$$BE_{sp1} = \sum_1^{26} \left(\sum_{i=1}^n (SPNG_{tf} * PRST_{tf} * LCV_{NG} * EF_{NG}) \right); \quad (Equation 7)$$

Where:

BE_{sp1} - is the sum of baseline emissions of subproject from each month of the monitoring period, [tCO₂];

$SPNG_{tf}$ - is the baseline ex-ante specific NG consumption of the 26 reconstructed furnaces, [1000nm³/t steel];

$PRST_{tf}$ - is the production steel level of each of the reconstructed thermal and heating furnaces in the month i, [tonnes].

The baseline emissions for SP2 [tCO₂/y] are:

$$BE_{sp2} = \sum_{i=1}^n (SPH_{VD} * PRVS_{VD,i} * EB_{DHC} * EF_{Coal} + SPEL_{VD} * PRVS_{VD,i} * EF_{el,y}); \text{ (Equation 8)}$$

Where:

BE_{sp2} - is the sum of baseline emissions of subproject 2 from each month of the monitoring period, [tCO₂];

SPH_{VD} - is a baseline ex ante specific heat consumption of the old VD, [MWh/t];

$PRVS_{VD,i}$ - is the monthly production volume of vacuumed steel, [t];

EB_{DHC} - is the efficiency of the steam boilers at the DHC;

EF_{Coal} - is the emission factor for local (anthracite) coal burning, [tCO₂/MWh];

$SPEL_{VD}$ - is a baseline ex ante specific electrical consumption of the old VD, [MWh/t];

$EF_{el,y}$ - is the calculated emission factor of the Ukrainian grid, [tCO₂/MWh].

The baseline emissions for SP3 [tCO₂/y] are:

$$BE_{sp3} = \sum_{i=1}^n (SPEL_{ES} * PRES_i * EF_{el,y}); \text{ (Equation 9)}$$

Where:

BE_{sp3} - is the sum of baseline emissions of subproject 3 from each month of the monitoring period, [tCO₂];

$SPEL_{ES}$ - is the baseline ex ante specific consumption of electricity per tone of electro steel, [MWh/t steel];

$PRES_i$ – is the monthly production volume of electro steel, [t].

The annual baseline emissions for SP4 [tCO₂/y] are:

$$BE_{sp4} = \sum_{i=1}^n (T_{pp} * EL_{MOT} * EF_{el,y}); \text{ (Equation 10)}$$

Where:

BE_{sp4} - is the sum of baseline emissions of subproject 4 from each month of the monitoring period, [tCO₂];

T_{pp} - is a working hours of the press in the month i, [h];

EL_{MOT} - is the press’ serving motors before reconstruction, [MW].

4Q 2010	
Baseline emissions	[tCO₂e]
Subproject 1. Reconstruction of thermal and heating furnaces	56963
Subproject 2. Installation of a new vacuum system	11937
Subproject 3. Installation of an arc ladle furnace	25135
Subproject 4. Modernization of press equipment	13254
Total for third quarter of 2010	107288

Table 16: Baseline emissions

D.3.3. Leakage:

Not Applicable

D.3.4. Summary of the emissions reductions during the monitoring period:

4Q 2010	
Emission Reductions	[tCO₂e]
Subproject 1. Reconstruction of thermal and heating furnaces	47272
Subproject 2. Installation of a new vacuum system	11896
Subproject 3. Installation of an arc ladle furnace	4194
Subproject 4. Modernization of press equipment	12629
Total for third quarter of 2010	75991

Table 17: Emission Reductions