

MONITORING REPORT

JI0077 - CMM utilisation on the coal mine Shcheglovskaya-Glubokaya of the State Holding Joint-Stock Company „GOAO Shakhtoupravlenye Donbass“

Monitoring Report 02

Monitoring period
01/04/2010 to 15/03/2011

Version 5
19 May 2011

CONTENTS

- A. General project activity and monitoring information
- B. Key monitoring activities
- C. Quality assurance and quality control measures
- D. Calculation of GHG emission reductions

Annexes

- Annex 1: References
- Annex 2: Technical drawing
- Annex 3: Energy and material flowchart including metering positions
- Annex 4: Deviation from the monitoring plan as stated in the PDD
- Annex 5: Differences between the determined PDD and implemented project
- Annex 6: History of the document

SECTION A. General project activity information

A.1 Title of the project activity:

CMM utilisation on the coal mine Shcheglovskaya-Glubokaya of the State Holding Joint-Stock Company „GOAO Shakhtoupravlenye Donbass“

Table - 1 Parties involved in the project

Party involved (*) (host) indicates a host Party)	Legal entity project participant (as applicable)	Please indicate if the Party involved wishes to be considered as project participant (Yes/No)
Netherlands	Carbon-TF B.V.	no
Ukraine (host)	State Holding Joint-Stock Company „GOAO Shakhtoupravlenye Donbass“	no

A.2. JI registration number:

UA2000015, JI0077

The project is approved as JI-project since 08/12/2009.

(http://ji.unfccc.int/JI_Projects/DeterAndVerif/Verification/FinDet.html)

Details of the project approval can be found under Annex I of this Monitoring Report.

A.3. Short description of the project activity:

In this project CMM, which has been sucked out of the active coal mine “Shcheglovskaya-Glubokaya”, has been utilised in upgraded previous coal boilers, a ventilation air heater, a flare, a cogeneration unit and an emergency generator. The methane has been burned to less harmful CO₂. The units have generated heat and power which have displaced conventionally produced heat and power and gained an additional amount of CO₂ reductions.

The ventilation air heater is working only in a short period of about four months in the winter.

The emergency generator was not working during this monitoring period.

The winter boiler house worked until 19/04/2010, after that summer boiler house has worked until 06/10/2010.

The production of the flare has significantly lowered since November 2009. The flare has been shut down at 23/10/2010 due to lacking gas amount and has been finally moved to the Coal Mine Nr.22 Kommunarskaya, JI0078 at 29/10/2010. This is temporary decision and in summer 2011 flare will be returned on site of the coal mine Shcheglovskaya-Glubokaya (after stopping of the winter boilers).

Starting with the winter 2009/2010 the available utilisable CMM amount has significantly fallen down. The reason is a change to a new coal seam, which has surprisingly only very low CH₄ concentration. Consequently the CH₄-utilisation decreased.

Table - 2 Amount of methane utilised for heat and power generation

Unit	period	CH ₄ [t/period]	Heat and power generated [MWh]
Boilers	01/04/2010-15/03/2011	1,592	8,257
Ventilation Air Heater	01/04/2010-15/03/2011	137	1,844
Flare	01/04/2010-23/10/2010	577	n.a.
Cogeneration unit	01/04/2010-15/03/2011	966	4,206
Emergency generator	01/04/2010-15/03/2011	0	0
Total	2010-2011	3,272	n.a.

A.4. Monitoring period:

Start date 01/04/2010

End date 15/03/2011

Start day and end day included.

A.5. Methodology applied to the project activity (incl. version number):**A.5.1. Baseline methodology:**

The approved consolidated methodology ACM0008 / Version 03 "Consolidated baseline methodology for coal bed methane and coal mine methane capture and use for power (electrical or motive) and heat and/or destruction by flaring") has been used to identify the baseline scenario of the proposed JI project [ACM0008].

According to ACM0008 the methodological "Tool to determine project emissions from flaring gases containing methane", EB 28 Meeting report, Annex 13, has been taken for the determination of the project emissions from flaring. In difference to the flaring tool, a combustion efficiency of 99.5%, according to the IPCC 1996 guidelines, has been taken into account instead of the default value of 90% as given in the flaring tool.

A.5.2. Monitoring methodology:

A monitoring plan provided by the "Approved consolidated baseline methodology ACM0008", Version 03, Sectoral Scope: 8 and 10, EB28 is applied to the project [ACM0008]. According to ACM0008 the methodological "Tool to determine project emissions from flaring gases containing methane", EB 28 Meeting report, Annex 13, has been taken for the determination of the project emissions from flaring. In difference to the flaring tool, a combustion efficiency of 99.5%, according to the IPCC 1996 guidelines, has been taken into account instead of the default value of 90% as given in the flaring tool. This is according to the PDD.

MONITORING REPORT FORM

Applicability requirements for the monitoring plan of the ACM008 methodology are identical to respective requirements of the baseline setting.

A.6. Status of implementation including time table for major project parts:

The project has not been installed as planned in the PDD. Only one of two flares has been installed and has been removed in 2011 due to lacking gas amount.

Table - 3 Status of Implementation

Units: three identical upgraded previously coal fired boilers	
Manufacturer: Biysk Boiler Plant	
Type: DKV-10-13	
Serial Numbers (not visible): 470 (No 1), 11781 (No 3), 12645 (No 4)	
Inventar Numbers (visible): 227655 (No 1), 227654 (No 3), 227652 (No 4)	
Capacity: 3-7 Gcal/h (approx. 7.6 MW)	
Efficiency heat generation: 90%	
Activity Inventar Nummer 227652 (No 4)	Status
year of construction	1967
last major overhaul	2008 - Ukrteploservis 2009 – Donbassvugleavtomatika
Last inspection	2007 - Derzhpromnaglyad 2010 – Donbassvugleavtomatika
Upgrade, initial operation, first tests	Summer 2006
Start of operation	October 2006
Planned installation date [PDD]	10/2006
Activity Inventar Nummer 227654 (No 3)	Status
year of construction	1967
Last inspection	2008 - Derzhpromnaglyad 2010 – Donbassvugleavtomatika
Upgrade, initial operation, first tests	Summer 2007
Start of operation	October 2007
Planned installation date [PDD]	10/2006
Activity Inventar Nummer 227655 (No 1)	Status
year of construction	1957
Last inspection	2008 - Derzhpromnaglyad 2010 – Donbassvugleavtomatika
Upgrade, initial operation, first tests	Summer 2006
Start of operation	October 2006
Planned installation date [PDD]	10/2006
Units: two identical upgraded previously coal fired boilers	
Manufacturer: Biysk Boiler Plant	
Type: E-1/9	
Serial Numbers	
Inventar Numbers (visible): 227656, 227657	
Capacity: 1 Gcal/h (approx. 1.167 MW)	

MONITORING REPORT FORM

Efficiency heat generation: 89%	
Activity Inventar Nummer 227656	Status
year of construction	
last major overhaul	2008 - Ukrteploservis
Last inspection	2007 - Derzhpromnaglyad 2010 - Donbassvugleavtomatika
Upgrade, initial operation, first tests	Summer 2006
Start of operation	Summer 2006
Planned installation date [PDD]	06/2006
Activity Inventar Nummer 227657	Status
year of construction	
Last inspection	2008 - Derzhpromnaglyad 2010 - Donbassvugleavtomatika
Upgrade, initial operation, first tests	Summer 2006
Start of operation	Summer 2006
Planned installation date [PDD]	06/2006

The heat meter B-2, which should be connected to boiler #3 produced no reasonable data within the period. Actually zero is taken into account as produced heat amount for B-2.

Unit: ventilation air heater (VAH)	
Manufacturer: Kamensk Plant	
Type: WGS 1,0	
Serial Number: 3, 4, 8, 10	
Capacity: four modules a 1 MW	
Efficiency heat generation: 98.5%	
Activity	Status
year of construction	1997-1999
Last inspection	2007 - Derzhpromnaglyad 2010 - Donbassvugleavtomatika
Upgrade, initial operation, first test	Summer 2006
Start of operation	01/11/2006
Planned installation date [PDD]	11/2006

The ventilation air heater consists of four identical modules, three of which can be in operation simultaneously due to due to restrictions from the ventilation shaft. So a maximum of 3 MW heat capacity results.

Unit: Flare	
Manufacturer: Pro2 Anlagentechnik GmbH	
Type: KGUU 5/8	
Serial Number: 142401	
Capacity: 10 MW	
Efficiency methane combustion: 99.5%	
Combustion temperature: 850°C	
Activity	Status

MONITORING REPORT FORM

Year of construction	2008
Last inspection	2009 – AS Wärmetechnik GmbH
Start of operation	29/05/2009
End of operation	October 2010
Planned installation date [PDD]	03/2009
Deinstallation date:	29/10/2010

Unit: cogeneration unit	
Manufacturer: Pro2 Anlagentechnik GmbH using a gas engine from Deutz AG	
Type: NC620K16	
Serial Number: 146401	
Capacity: 3.750 MW firing, 1.35 MW _{el} , 0.93 MW _{th}	
Activity	Status
Year of construction	2000
Last major overhaul	September 2009
Last inspection	none
Date of installation	October 2009
Start of operation	29/10/2009
Planned installation date [PDD]	06/2009

Unit: emergency generator	
Manufacturer: Pervomaysk Diesel Factory	
Type: BGZHCHN 25-34-I (БГЖЧН 25-34-I)	
Serial Number: IFYUYA (ИФЮЯ) 1440000 103	
Capacity: approx. 1.111 MW firing, 0,4 MW _{el}	
Activity	Status
Year of construction	1996
Last major overhaul	n.a.
Last inspection	n.a.
Start of operation	07/2006
Planned installation date [PDD]	07/2006

The coordinates given in the PDD uses the SK-42 reference system which uses a slightly different reference ellipsoid than the WGS84 system used by Google. The SK-42 system and the substantial cartography are still in use in the most CIS countries and Ukraine too. The WGS84 coordinates are: 47°03'45" N, 37°51'55" E

A.7. Intended deviations or revisions to the registered PDD:

The first flare has been moved to another JI project, JI0078 at «Coal Mine Nr.22 Kommunaraskaya». The second flare was not installed due to Global Financial Crisis. Both flares are now pending due to the lacking gas amount. The flares will be re-installed as soon as the eligible gas amount will be available. The additionality of the project has been checked by TUEV Sued during the last verification and is still given.

MONITORING REPORT FORM

Table - 4 Implementation plan

unit	installation date (PDD)	firing capacity	Date of installation or envisaged new date of installation new timetable
boiler No: 1	10/2006	7,600 kW	October 2006
boiler No: 2	10/2006	7,600 kW	October 2006
boiler No: 3	10/2007	7,600 kW	October 2007
summer boiler 1	6/2006	700 kW	Summer 2006
summer boiler 2	6/2006	700 kW	Summer 2006
ventilation air heater	11/2006	3,000 kW	November 2006
emergency power generation unit	07/2006	400 kW total ..160 KW CMM	July 2006
flare No: 1	03/2009	5,000 kW	March 2009 removed in October 2010 <i>re-installation pending</i>
flare No: 2	09/2009	5,000 kW	<i>pending</i>
cogeneration unit	06/2009	1,350 kW _{el}	October 2009

A.8. Intended deviations or revisions to the registered monitoring plan:

A revised monitoring plan has been provided. See <Revised Monitoring Plan-SG.pdf>

The calculation of the emission reductions is not calculated on a yearly basis, but for an individual period. See A.4. for detailed data.

Flow data and flare efficiency as well as the methane amount destroyed by flaring MD_{F1} are calculated in 15 min. intervals in Excel sheets. The main emissions variables for project emissions, baseline emissions and emissions reductions are calculated on a monthly basis. Yearly sums and a total sum for the monitoring are calculated.

The formula for the calculation of project emissions from uncombusted methane has been updated. Formulae from the «Methodological “Tool to determine project emissions from flaring gases containing methane”» [AM_Tool_07]) have been applied, see Annex 4. The calculation of project emissions from uncombusted methane from flaring is now more accurate.

The heat amount produced by the ventilation air heater and the power amount produced by the emergency power generation have not been measured but calculated using the utilised methane amount. Additionally monitoring procedures applied during the monitoring period are described in Annex 3.

A.9. Changes since last verification:

The flare has been moved to the other JI project of the project owner JI0078 at «Coal Mine Nr.22 Kommunarskaya».

An electronically monitoring system has been installed for the monitoring of the gas amount sent to summer boilers. A heat meter for the produced heat has been installed.

A.10. Person(s) responsible for the preparation and submission of the monitoring report:

Coal Mine Shcheglovskaya-Glubokaya

- Viktor Ivanovich Orlov, Chief Engineer

Eco-Alliance OOO

- Vladimir Kasyanov, Managing Director
- Pavel Shelegheda, Deputy Director
- Aleksandr Didenko, Monitoring Assistant
- Viktor Avtonomov, Monitoring Assistant

Carbon-TF B.V

- Adam Hadulla, Director Business Development
- Karl Wöste, Senior Consultant

MONITORING REPORT FORM

SECTION B. Key monitoring activities

B.1. Monitoring equipment:

B.1.2. Table providing information on the equipment used (incl. manufacturer, type, serial number, date of installation, date of last calibration, information to specific uncertainty, need for changes and replacements):

Table - 5 Monitoring equipment

ID	Data	Method	Manufacturer	Classification	Serial number	Frequency of Measurement	Installation	Uncertainty level of data	Range	Calibration procedure	Last calibration	Calibrator
3	NMHC concentration	Gas chromatograph	Gazohrom	LHM-8MD	75 307	yearly	n. n.	2.5%	0-100%	The approved laboratory is responsible for regular recalibrations of the system.	14/10/2009 15/10/2010	Donetsk Standard Metrologya
5	CMM amount to winter boilers	Standard orifice and pressure difference meter	ECO-Alliance OOO	Calculation	none	Continuous record period 15 min.	31/03/2010		n.a.	Calculation	n.a	n.a.
5a	Gas flow (boiler)	Standard orifice	Himpe AG	Annular chamber standard orifice DIN 19205	none	Continuous record period 15 min.	31/03/2010	0.74%	0-8,000 m ³ /h	Calibrations made using procedures of Sumystandart-metrology. Calibration frequency – 1 year.	Calibration will be spent in April 2011	Sumystandart-metrology
5b	Pressure difference (boiler)	Pressure difference transmitter	Honeywell	STD-3000	09W33 C3180872001001	Continuous record period 15 min.	31/03/2010	0.0375 %	0-100 mbar	Initial calibration made using procedures of manufacturer. Further calibrations made using procedures of Sumystandart-metrology. Calibration frequency – 1 year.	15/09/2009 Calibration will be spent in April 2011	Honeywell Sumystandart-metrology

MONITORING REPORT FORM

ID	Data	Method	Manufacturer	Classification	Serial number	Frequency of Measurement	Installation	Uncertainty level of data	Range	Calibration procedure	Last calibration	Calibrator
5c	Pressure (boiler)	Pressure transmitter	Siemens	SITRANS P Serie Z 7MF1564	AZB/X1110844	Continuous record period 15 min.	31/03/2010	0.25%	0-1.6 bar abs	Initial calibration made using procedures of manufacturer. Further calibrations made using procedures of Sumystandart-metrology. Calibration frequency – 1 year.	Initial unknown Calibration will be spent in April 2011	SIEMENS Sumystandart-metrology
5d	Temperature (boiler)	Resistance thermometer	JUMO	dTRANS TO1 Typ 90.2820/10	TN00515987 01266669010 08400007	Continuous record period 15 min.	31/03/2010	DIN EN 60751, Class B 0.3+0.005T	-40-120°C	Initial calibration made using procedures of manufacturer. Further calibrations made using procedures of Sumystandart-metrology. Calibration frequency – 1 year.	Initial unknown Calibration will be spent in April 2011	JUMO Sumystandart-metrology
5e	CH ₄ concentration (boiler)	Infrared meter	SIEMENS	ULTRAMAT23	F-Nr-N1-WN-925	Continuous record period 15 min.	31/03/2010	1.5 %	0-100% CH ₄	Calibrations made using procedures of Sumystandart-metrology. Calibration frequency – 1 year.	20/12/2010 passport to gasanalyzer № N1-WN-925	Sumystandart-metrology
6	CMM amount to VAH	Standard orifice and pressure difference meter	ECO-Alliance OOO	calculation	none	Continuous record period 15 min.	31/03/2010	n.a.	n.a.	Calculation	n.a.	n.a.

MONITORING REPORT FORM

ID	Data	Method	Manufacturer	Classification	Serial number	Frequency of Measurement	Installation	Uncertainty level of data	Range	Calibration procedure	Last calibration	Calibrator
6a	Gas flow (VAH)	Standard orifice	Himpe AG	Annular chamber standard orifice DIN 19205	none	Continuous record period 15 min.	31/03/2010	0.54 % DIN EN ISO 5167-T.1-4	0-1,200 m ³ /h	Calibrations made using procedures of Sumystandart-metrology. Calibration frequency – 1 year.	Calibration will be spent in April 2011	Sumystandart-metrology
6b	Pressure difference (VAH)	Pressure difference transmitter	Honeywell	STD-3000	09W12 C3149127001001	Continuous record period 15 min.	31/03/2010	0.0375 %	0-100 mbar	Initial calibration made using procedures of manufacturer. Further calibrations made using procedures of Sumystandart-metrology. Calibration frequency – 1 year.	15/09/2009 Calibration will be spent in April 2011	Honeywell Sumystandart-metrology
6c	Pressure (VAH)	Pressure transmitter	Siemens	SITRANS P Serie Z 7MF1564	AZB/X1110845	Continuous record period 15 min.	31/03/2010	0.25%	0-1.6 bar abs	Initial calibration made using procedures of manufacturer. Further calibrations made using procedures of Sumystandart-metrology. Calibration frequency – 1 year.	Initial unknown Calibration will be spent in April 2011	SIEMENS Sumystandart-metrology

MONITORING REPORT FORM

ID	Data	Method	Manufacturer	Classification	Serial number	Frequency of Measurement	Installation	Uncertainty level of data	Range	Calibration procedure	Last calibration	Calibrator
6d	Temperature (VAH)	Resistance thermometer	JUMO	dTRANS TO1 Typ 90.2820/10	TN00515987 01266669010 08400002	Continuous record period 15 min.	31/03/2010	DIN EN 60751, Class B 0.3+0.005T	-40-120°C	Initial calibration made using procedures of manufacturer. Further calibrations made using procedures of Sumystandart-metrology. Calibration frequency – 1 year.	Initial unknown Calibration will be spent in April 2011	JUMO Sumystandart-metrology
7	CMM amount to flare	Standard orifice and pressure difference meter	Pro2 Anlagentechnik GmbH	calculation	none	Continuous record period 15 min.	03/2009		n.a.	Calculation	none	none
7a	Gas flow (flare)	Standard orifice	Himpe AG	annular chamber standard orifice DIN 19205	501871 (SG-F1)	Continuous record period 15 min.	13/11/2009	0.75% DIN EN ISO 5167-T.1-4	0-2,500 m ³ /h	Calibrations made using procedures of Sumystandart-metrology. Calibration frequency – 1 year.	27/10/2010 passport to flow meter № 501871 (SG-F1)	Sumystandart-metrology
7b	Pressure difference (flare)	Pressure difference transmitter	Honeywell	STD-3000	08W18 C3059154001003	Continuous record period 15 min.	03/2009	0.25%	0-100 mbar	Calibrations made using procedures of Sumystandart-metrology. Calibration frequency – 1 year.	27/10/2010 certificate № 2135	Sumystandart metrologiya
7c	Pressure (flare)	Pressure transmitter	Noeding	P 121 E02-311	EX812126966	Continuous record period 15 min.	03/2009	0.25%	0-250 mbar, rel	Calibrations made using procedures of Sumystandart-metrology. Calibration frequency – 1 year.	02/11/2010 certificate № 2171	Sumystandart metrologiya

MONITORING REPORT FORM

ID	Data	Method	Manufacturer	Classification	Serial number	Frequency of Measurement	Installation	Uncertainty level of data	Range	Calibration procedure	Last calibration	Calibrator
7d	Temperature (flare)	Resistance thermometer	JUMO GmbH	dTRANS TO1 Typ 90.2820/10	4571/1	Continuous record period 15 min.	03/2009	DIN EN 60751, Class B 0.3+0.005T	-50-250°C	Calibrations made using procedures of Sumystandart-metrology. Calibration frequency – 1 year.	27/10/2010 passport to Resistance thermometer № 4571/1	Sumystandart metrologiya
7e	CH ₄ concentration (flare)	Infrared meter	Pro 2 Anlagentechnik GmbH	BINOS 100	120482003017	Continuous record period 15 min.	03/2009	1.5%	0-100% CH ₄	Initial calibration made using procedures of manufacturer. Further calibrations made using procedures of Sumystandart-metrology. Calibration frequency – 1 year. Calibrations made using procedures of Eco-Alliance OOO every two weeks	01/12/2010 passport to gas analyzer № 120482003017	Sumystandart metrologiya Eco-Alliance OOO
8	CMM amount to cogeneration unit	Standard orifice and pressure difference meter	Pro2 Anlagentechnik GmbH	calculation	none	Continuous record period 15 min.	10/2009		n.a.	Calculation	n.a.	n.a.
8a	Gas flow (cogeneration unit)	Standard orifice	Himpe AG	annular chamber standard orifice DIN 19205	501029	Continuous record period 15 min.	10/2009	0.56 % DIN EN ISO 5167-T.1-4	0-1,200 m ³ /h	Calibrations made using procedures of Sumystandart-metrology. Calibration frequency – 1 year.	31/03/2010 passport to flow meter № 501029	Sumystandart metrologiya

MONITORING REPORT FORM

ID	Data	Method	Manufacturer	Classification	Serial number	Frequency of Measurement	Installation	Uncertainty level of data	Range	Calibration procedure	Last calibration	Calibrator
8b	Pressure difference (cogeneration unit)	Pressure difference transmitter	Honeywell	STD-3000	08W18 C3059154001002	Continuous record period 15 min.	10/2009	0.25%	0-100 mbar	Calibrations made using procedures of Sumystandart-metrology. Calibration frequency – 1 year.	31/03/2010 certificate № 0482	Sumystandart metrologya
8c	Pressure (cogeneration unit)	Pressure transmitter	Noeding	P 121	EX812127132	Continuous record period 15 min.	10/2009	0.25%	0-250 mbar	Calibrations made using procedures of Sumystandart-metrology. Calibration frequency – 1 year.	31/03/2010 certificate № 0484	Sumystandart metrologya
8d	Temperature (cogeneration unit)	Resistance thermometer	JUMO GmbH	dTRANS TO1 Typ 90.2820/10	TN00515988 01264830010 08370001 (98023 for calibration)	Continuous record period 15 min.	10/2009	DIN EN 60751, Class B 0.3+0.005T	-40-120°C	Calibrations made using procedures of Sumystandart-metrology. Calibration frequency – 1 year.	31/03/2010 passport to Resistance thermometer № 98023	Sumystandart metrologya
9	Flame temperature of the flare	Thermocouple	Herth GmbH	DIN 43733, Type S, PtRh-Pt	71089 until 10/11/2009 66315 since 10/11/2010	Continuous record period 15 min.	10/2010	DIN 43733, Class 2 0°C - 600°C +/-1.5 K 600°C - 1600°C +/- 0.25%	0-1,700°C	Initial calibration made using procedures of manufacturer. None, thermocouple is supposed to be changed at least one time per year, according to the flaring tool	Isn't subject to calibration, as changes every year	Herth
10	Power production	Electricity meter	NZR	IGZ-FDWB7307	475072	Continuous, cumulative value Read period daily	10/2009	Class 1 IEC 1036	n.a.	Calibration made using procedures of manufacturer using German Calibration Standards (Eichvorschriften) Valid for 8 years.	2006	NZR

MONITORING REPORT FORM

ID	Data	Method	Manufacturer	Classification	Serial number	Frequency of Measurement	Installation	Uncertainty level of data	Range	Calibration procedure	Last calibration	Calibrator
10a	Power production	Electricity meter	Kuhse	KMU45B	82365	Continuous, cumulative value Read period daily	2008 2010	0.1% U 0.15% I	n.a.	Initial calibration made using procedures of manufacturer.	02/02/2010	Kuhse
11	Heat production winter boilers	Calculation	ECO-Alliance OOO	none	none	Continuous record period 15 min.	31/03/2010		n.a.	calculation	n.a.	n.a.
11a	Inlet temperature one measurement for all three boilers 1,3,4	Resistance thermometer	AOZT «TERA»	TSP U 1-3 PT-100	09456	Continuous record period 15 min.	31/03/2010	0.5%	-50-250°C	Initial calibration made using procedures of manufacturer. Further calibrations made using procedures of Sumystandart-metrology. Calibration frequency – 1 year.	12/2009 Calibration will be spent in April 2011	Manufacturer Sumystandart metrologiya
11.4	Heat production boiler 4	Heat meter	ECO-Alliance OOO	calculation	none	Continuous record period 15 min.	31/03/2010		n.a.	n.a.	n.a.	n.a.
11.4a	Water flow Boiler 4	Standard orifice	Lvivpribor	n.a.	4	n.a.	10/2009	Unknown, set to 2.5%)	0-400 m³/h	Yearly inspection made using procedures of Donbassvugleavtomatyka	12/10/2009	Donbassvugleavtomatyka
11.4b	Pressure difference (boiler 4)	Pressure difference transmitter	Lvivpribor	DM3583M	19 Inventar Nr: 105321	Continuous record period 15 min.	10/2009	1.5%	0-25 kPa	Calibration made using procedures of Donbassvugleavtomatyka. Calibration frequency – 1 year.	29/12/2010	Donbassvugleavtomatyka

MONITORING REPORT FORM

ID	Data	Method	Manufacturer	Classification	Serial number	Frequency of Measurement	Installation	Uncertainty level of data	Range	Calibration procedure	Last calibration	Calibrator
11.4c	Indicator (boiler 4)	Chart Recorder	Lvivpribor	KSD-023	9056848	Continuous record period 15 min.	10/2009	1.0%	0-400 m ³ /h	Calibration made using procedures of Donbassvugleavtomatyka. Calibration frequency – 1 year.	29/12/2010	Donbassvugle avtomatyka
11.4d	Outlet temperature Boiler 4	Resistance thermometer	AOZT «TERA»	TSP U 1-3 PT-100	09444	Continuous record period 15 min.	31/03/2010	0.5%	-50-250°C	Initial calibration made using procedures of manufacturer. Further calibrations made using procedures of Sumystandart-metrology. Calibration frequency – 1 year.	12/2009 Calibration will be spent in April 2011	Manufacturer Sumystandart metrologya
11.3	Heat production boiler 3	Heat meter	ECO-Alliance OOO	calculation	none	Continuous record period 15 min.	31/03/2010		n.a.	n.a	n.a.	n.a.
11.3a	Water flow Boiler 3	Standard orifice	Lvivpribor	DM3583M	3	Continuous record period 15 min.	10/2009	Unknown, set to 2.5%	0-250 m ³ /h	Yearly inspection made using procedures of Donbassvugleavtomatyka.	12/10/2009	Donbassvugle avtomatyka
11.3b	Pressure difference (boiler 3)	Pressure difference transmitter	Lvivpribor	KSD-023	71329 Inventar Nr: 105621	Continuous record period 15 min.	10/2009	1.5%	0-25 kPa	Calibration made using procedures of Donbassvugleavtomatyka. Calibration frequency – 1 year.	29/12/2010	Donbassvugle avtomatyka

MONITORING REPORT FORM

ID	Data	Method	Manufacturer	Classification	Serial number	Frequency of Measurement	Installation	Uncertainty level of data	Range	Calibration procedure	Last calibration	Calibrator
11.3c	Indicator (boiler 3)	Chart Recorder	Lvivpribor	KSD-023	4014777	Continuous record period 15 min.	10/2009	1.0%	0-250 m ³ /h	Calibration made using procedures of Donbassvugleavtomatyka. Calibration frequency – 1 year.	29/12/2010	Donbassvugleavtomatyka
11.3d	Outlet temperature Boiler 3	Resistance thermometer	AOZT «TERA»	TSP U 1-3 PT-100	09448	Continuous record period 15 min.	31/03/2010	0.5%	-50-250°C	Initial calibration made using procedures of manufacturer. Further calibrations made using procedures of Sumystandart-metrology. Calibration frequency – 1 year.	12/2009 Calibration will be spent in April 2011	Manufacturer Sumystandart metrologiya
11.1	Heat production boiler 1	Heat meter	ECO-Alliance OOO	calculation	none	Continuous record period 15 min.	31/03/2010		n.a.	n.a	n.a.	n.a.
11.1a	Water flow Boiler 1	Standard orifice	Lvivpribor	DM3583M	1	Continuous record period 15 min.	10/2009	Unknown, set to 2.5%	0-320 m ³ /h	Yearly inspection made using procedures of Donbassvugleavtomatyka	14/10/2009	Donbassvugleavtomatyka
11.1b	Pressure difference (boiler 1)	Pressure difference transmitter	Lvivpribor	KSD-023	n.n. Inventar Nr: 101503	Continuous record period 15 min.	10/2009	1.5%	0-25 kPa	Calibration made using procedures of Donbassvugleavtomatyka. Calibration frequency – 1 year.	29/12/2010	Donbassvugleavtomatyka

MONITORING REPORT FORM

ID	Data	Method	Manufacturer	Classification	Serial number	Frequency of Measurement	Installation	Uncertainty level of data	Range	Calibration procedure	Last calibration	Calibrator
11.1c	Indicator (boiler 1)	Chart Recorder	Lvivpribor	KSD-023	8087123	Continuous record period 15 min.	10/2009	1.0%	0-320 m ³ /h	Calibration made using procedures of Donbassvugleavtomatyka. Calibration frequency – 1 year.	29/12/2010	Donbassvugleavtomatyka
11.1d	Outlet temperature Boiler 1	Resistance thermometer	AOZT «TERA»	TSP U 1-3 PT-100	09451	Continuous record period 15 min.	31/03/2010	0.5%	-50-250°C	Initial calibration made using procedures of manufacturer. Further calibrations made using procedures of Sumystandart-metrology. Calibration frequency – 1 year.	12/2009 Calibration will be spent in April 2011	Manufacturer Sumystandart metrologiya
12	CMM amount to summer boiler	Standard orifice and pressure difference meter	ECO-Alliance OOO	calculation	none	Continuous record period 15 min.	05/06/2010		n.a.	Calculation	n.a	n.a.
12a	Gas flow (summer boiler)	Standard orifice	PRPE "Energoteh"	Annular chamber standard orifice DIN 19205	none	Continuous record period 15 min.	17/06/2010	None	58.49...300 m ³ /h	Initial calibration made using procedures of manufacturer. Further calibrations made using procedures of Sumystandart-metrology. Calibration frequency – 1 year.	16/06/2010 Calibration will be spent in April 2011	"Energoteh" Sumystandart metrologiya

MONITORING REPORT FORM

ID	Data	Method	Manufacturer	Classification	Serial number	Frequency of Measurement	Installation	Uncertainty level of data	Range	Calibration procedure	Last calibration	Calibrator
12b	Pressure difference (summer boiler)	Pressure difference transmitter	Honeywell	STD-3000	09W33 C3180872001001	Continuous record period 15 min.	Will be installed at transition to summer boilers from winter boilers	0.0375 %	0-100 mbar	Initial calibration made using procedures of manufacturer. Further calibrations made using procedures of Sumystandart-metrology. Calibration frequency – 1 year.	15/09/2009 Calibration will be spent in April 2011	Honeywell Sumystandart-metrologya
12c	Pressure (summer boiler)	Pressure transmitter	Siemens	SITRANS P Serie Z 7MF1564	AZB/X1110844	Continuous record period 15 min.	Will be installed at transition to summer boilers from winter boilers	0.5%	0-1.6 bar abs	Initial calibration made using procedures of manufacturer. Further calibrations made using procedures of Sumystandart-metrology. Calibration frequency – 1 year.	Initial unknown Calibration will be spent in April 2011	SIEMENS Sumystandart-metrology
12d	Temperature (summer boiler)	Resistance thermometer	JUMO	dTRANS TO1 Typ 90.2820/10	TN00515987 01266669010 08400007	Continuous record period 15 min.	Will be installed at transition to summer boilers from winter boilers	DIN EN 60751, Class B 0.3+0.005T	-40-120°C	Initial calibration made using procedures of manufacturer. Further calibrations made using procedures of Sumystandart-metrology. Calibration frequency – 1 year.	Initial unknown Calibration will be spent in April 2011	JUMO Sumystandart-metrology
13	Heat production summer boiler	Calculation	ECO-Alliance OOO	none	none	Continuous record period 15 min.	05/06/2010		n.a.	calculation	n.a.	n.a.

MONITORING REPORT FORM

ID	Data	Method	Manufacturer	Classification	Serial number	Frequency of Measurement	Installation	Uncertainty level of data	Range	Calibration procedure	Last calibration	Calibrator
13a	Hot water flow (summer boiler)	Standard orifice	PRPE "Energoteh"	Annular chamber standard orifice DIN 19205	none	Continuous record period 15 min.	17/06/2010	none	12.13...65 m3/h	Initial calibration made using procedures of manufacturer. Further calibrations made using procedures of Sumystandart- metrology. Calibration frequency – 1 year.	16/06/2010 Calibration will be spent in April 2011	"Energoteh" Sumystandart metrologiya
13b	Pressure difference (summer boiler)	Pressure difference transmitter	Honeywell	STD-3000	09W12 C3149127001001	Continuous record period 15 min.	Will be installed at transition to summer boilers from VAH	0.0375 %	0-100 mbar	Initial calibration made using procedures of manufacturer. Further calibrations made using procedures of Sumystandart- metrology. Calibration frequency – 1 year.	15/09/2009 Calibration will be spent in April 2011	Honeywell Sumystandart -metrology
13c	Pressure (summer boiler)	Pressure transmitter	Siemens	SITRANS P Serie Z 7MF1564	AZB/A2199936	Continuous record period 15 min.	05/06/2010	0.25%	0-10 bar abs	Initial calibration made using procedures of manufacturer. Further calibrations made using procedures of Sumystandart- metrology. Calibration frequency – 1 year.	Initial unknown Calibration will be spent in April 2011	SIEMENS Sumystandart -metrology

MONITORING REPORT FORM

ID	Data	Method	Manufacturer	Classification	Serial number	Frequency of Measurement	Installation	Uncertainty level of data	Range	Calibration procedure	Last calibration	Calibrator
13d	Temperature (summer boiler)	Resistance thermometer	AOZT «TERA»	TSP U 1-3 PT-100	09442	Continuous record period 15 min.	05/06/2010	0.5%	-50-250°C	Initial calibration made using procedures of manufacturer. Further calibrations made using procedures of Sumystandart-metrology. Calibration frequency – 1 year.	12/2009 Calibration will be spent in April 2011	AOZT «TERA» Sumystandart-metrology
13e	Temperature on an input (summer boiler)	Resistance thermometer	AOZT «TERA»	TSP U 1-3 PT-100	09443	Continuous record period 15 min.	05/06/2010	0.5%	-50-250°C	Initial calibration made using procedures of manufacturer. Further calibrations made using procedures of Sumystandart-metrology. Calibration frequency – 1 year.	12/2009 Calibration will be spent in April 2011	AOZT «TERA» Sumystandart-metrology

*) The calibration has been provided in Germany according to the German Calibration Act. The calibration is manifested by a test badge (Eichmarke) fixed to the unit and valid for 8 years.

B.1.3. Involvement of Third Parties:

The lab analysis for the determination of the NMHC concentration has been done by MAKNIИ

- The calibration of CH₄-concentration and some measurement units has been done by DTOV Donbasvugleavtomatyka
- Sumystandartmetrologiya has calibrated several units
- Eco-Alliance OOO supported the coal mine with the collecting of the monitoring data, electronically collected data have been provided to BV
- Carbon-TF B.V. has supervised the data for plausibility and completeness.

B.2. Data collection (accumulated data for the whole monitoring period):

B.2.1. List of fixed default values:

Table - 6 List of ex-ante fixed values

ID number	Data variable	Source of data	Data unit	Comment
P8, B49 CEF _{ELEC,PJ}	Carbon emission factor of CONS _{ELEC,PJ}	National Environmental Investment Agency of Ukraine, NEIA	tCO _{2eq} /MWh	Official Ukrainian data have been published at 28/03/2011 and 12/05/2011 at the NEIA website. According to the information given in the PDD these data are taken into account. Set to: 1.067 t CO ₂ / MWh (2010) 1.063 t CO ₂ / MWh (2011) Value for thermal power plants which are connected to the Ukrainian Power grid. [NEIA]
P13 Eff _{FL}	Flare combustion efficiency	monitored data, revised monitoring plan	t CH ₄	Set to: 99.5 % for: T _{Flame} > 850°C [PDD, ACM0008/IPCC] 90% for: 500°C < T _{Flame} < 850°C [AM_Tool_07] 0% for: T _{Flame} < 500°C [AM_Tool_07]
P16 Eff _{ELEC}	Efficiency of methane destruction / oxidation in power plant	ACM0008 / IPCC	%	set at 99.5% (IPCC)
P19 Eff _{HEAT}	Efficiency of methane destruction / oxidation in heat plant	ACM0008 / IPCC	%	set at 99.5% (IPCC)
P23, B19 CEF _{CH4}	Carbon emission factor for combusted methane	ACM0008 / IPCC	t CO _{2eq} /t CH ₄	set at 2.75 t CO _{2eq} /t CH ₄
P28, B18 GWP _{CH4}	Global warming potential of methane	ACM0008 / IPCC	t CO _{2eq} /t CH ₄	set at 21

MONITORING REPORT FORM

B55 EF _{HEAT}	CO ₂ emission factor of fuel used for captive power or heat	IPCC Guidelines 1 Introduction Table 1.2	tCO ₂ /MWh	set to 0.3406 tCO ₂ /MWh Using the value for "Other Bituminous Coal" of 94,600 kg CO ₂ /TJ, [IPCC-2]
B57 Eff _{COAL}	Energy efficiency of previously coal fired heat plant	Boiler pass	%	90.0 % upgraded winter boiler (measured value) 89.0 % summer boilers
Eff _{VAH}	Efficiency of the heat generation by ventilation air heater	VAH Technical report	%	Set to 97.25 % [Technical Report]
Eff _{EPG}	Efficiency of the power generation by emergency power generator	PDD	%	Set to 36% [PDD]
HV _{CH4}	Heating value of methane	DIN EN ISO 6976	kWh/m ³ MWh/t	set to 9.65 kWh/m ³ equal to 13.899 MWh/t

B.2.2. List of variables:

Table - 7 List of variables

ID number	Data variable	Source of data	Data unit	Comment
P1 PE	Project emissions	monitored data	tCO _{2eq}	calculated using formula (1) from the revised Monitoring Plan
P2 PE _{ME}	Project emissions from energy use to capture and use methane	monitored data	tCO _{2eq}	calculated using formula (2) from the revised Monitoring Plan
P3 PE _{MD}	Project emissions from methane destroyed	monitored data	tCO _{2eq}	calculated using formula (3) from the revised Monitoring Plan
P4 PE _{UM}	Project emissions from uncombusted methane	monitored data	tCO _{2eq}	calculated using formula (9) from the revised Monitoring Plan
P5 CONS _{ELEC,PJ}	Additional electricity consumption by project	monitored data	MWh	calculated using formula (31) from the revised Monitoring Plan
P11 MD _{FL}	Methane destroyed by flaring	monitored data	t CH ₄	calculated using formula (5) from the revised Monitoring Plan
P12 MM _{FL}	Methane sent to flare	flow meter	t CH ₄	
PE _{Flare}	Project emissions from flaring	monitored data	t CO _{2eq}	calculated using formula (9a) from the revised Monitoring Plan
T _{Flame}	Flame temperature of the flare	thermo couple	°C	
P14 MD _{ELEC}	Methane destroyed by power generation	monitored data	t CH ₄	calculated using formula (6) from the revised Monitoring Plan

MONITORING REPORT FORM

P15 MM _{ELEC}	Methane sent to power plant	flow meter	t CH ₄	calculated using formula (6a) from the revised Monitoring Plan
MM _{CHP}	Methane sent to cogeneration unit	flow meter	t CH ₄	measured, calculated using formula (29) from the revised Monitoring Plan for April 2010
MM _{EPG}	Methane sent to emergency power generator	flow meter	t CH ₄	
Eff _{CHP}	efficiency of power generation in the cogeneration unit	monitored data	%	calculated using formula (30) from the revised Monitoring Plan
P17 MD _{HEAT}	Methane destroyed by heat generation	monitored data	t CH ₄	calculated using formula (7) from the revised Monitoring Plan
P18 MM _{HEAT}	Methane sent to heat generation	monitored data	t CH ₄	calculated using formula (7a) from the revised Monitoring Plan
MM _{WBoil}	Methane sent to winter boilers	flow meter	t CH ₄	
MM _{WBoil}	Methane sent to summer boilers	flow meter	t CH ₄	
MM _{VAH}	Methane sent to ventilation air heater	flow meter	t CH ₄	
P24 CEF _{NMHC}	Carbon emission factor for combusted non methane hydrocarbons (various)	lab analysis	t CO ₂ /t _{NMHC}	Calculated if applicable
P25 PC _{CH4}	Concentration of methane in extracted gas	IR measurement	%	
P26 PC _{NMHC}	NMHC concentration in coal mine gas	lab analysis	%	Used to check if more than 1% of emissions and to calculate r
P27 r	Relative proportion of NMHC compared to methane	lab analysis	%	Calculated using formula (4) if applicable, based on the lab analysis.
B1 BE	Baseline emissions	monitored data	t CO _{2eq}	calculated using formula (10) from the revised Monitoring Plan
B3 BE _{MR}	Baseline emissions from release of methane into the atmosphere that is avoided by the project activity	monitored data	t CO _{2eq}	calculated using formula (14) from the revised Monitoring Plan
B4 BE _{Use}	Baseline emissions from the production of power, heat or supply to gas grid replaced by the project activity	monitored data	t CO _{2eq}	calculated using formula (24) from the revised Monitoring Plan
B14 CMM _{PJ}	CMM captured in the project activity	monitored data	t CH ₄	calculated using formula (14a) from the revised Monitoring Plan

MONITORING REPORT FORM

B46 GEN	electricity generation by project	monitored data	MWh	calculated using formula (27) from the revised Monitoring Plan
GEN _{CHP}	Electricity generated by the cogeneration unit	power meter	MWh	
GEN _{EPG}	Electricity generated by the emergency power generator	monitored data	MWh	calculated using formula (28) from the revised Monitoring Plan
B47 HEAT	Heat generation by project	monitored data	MWh	calculated using formula (25) from the revised Monitoring Plan
HEAT _{WBoil}	Heat generation by winter boilers	heat meter	MWh	Measured
HEAT _{SBoil}	Heat generation by summer boilers	heat meter	MWh	Measured
HEAT _{VAH}	Heat generation by Ventilation Air Heater	monitored data	MWh	calculated using formula (26) from the revised Monitoring Plan

B.2.3. Data concerning GHG emissions by sources of the project activity

Table - 8 GHG emissions by sources of the project activity

ID number	Data variable	Source of data	Data unit	Comment
P12 MM _{FL}	Methane sent to flare	flow meter	t CH ₄	Measured
P15 MM _{ELEC}	Methane sent to power plant	monitored data	t CH ₄	calculated using formula (6a) from the revised Monitoring Plan
P18 MM _{HEAT}	Methane sent to heat generation	monitored data	t CH ₄	calculated using formula (7a) from the revised Monitoring Plan
P25 PC _{CH4}	Concentration of methane in extracted gas	IR measurement	%	
P26 PC _{NMHC}	NMHC concentration in coal mine gas	lab analysis	%	Used to check if more than 1% of emissions and to calculate r.

B.2.4. Data concerning GHG emissions by sources of the baseline

Table - 9 GHG emissions by sources of the baseline

ID number	Data variable	Source of data	Data unit	Comment
B14 CMM _{PJ}	CMM captured in the project activity	monitored data	t CH ₄	calculated using formula (14a) from the revised Monitoring Plan
B47 HEAT	Heat generation by project	monitored data	MWh	calculated using formula (25) from the revised Monitoring Plan

MONITORING REPORT FORM

B46 GEN	electricity generation by project	monitored data	MWh	calculated using formula (27) from the revised Monitoring Plan
------------	--------------------------------------	-------------------	-----	--

B.2.5. Data concerning leakage

Not applicable.

B.2.6. Data concerning environmental impacts

SU Donbass is the owner of two coal mines, coal mine Shcheglovskaya-Glubokaya and Coal Mine Nr 22 Kommunaraskaya. SU Donbass started works on reducing greenhouse gas emissions already in 2006. As first pilot CMM utilisation two previously coal fired boilers at the coal mine Shcheglovskaya-Glubokaya have been upgraded with CMM burning systems. This early action has been verified as Greening AAU's. In the second phase further CMM utilisation units followed and a second JI project at Coal Mine Nr 22 Kommunaraskaya was initiated. At the time nearly all of the CMM from the suction system of both coal mines is utilised and no longer blown into atmosphere.

B.3. Data processing and archiving (incl. software used):

Two different but similar systems are used for electronically data collection.

Data from the boilers and the VAH are collected, processed and stored using a Siemens SIMATIC PLC S7 system and Siemens WINCC programming software. All data is stored in the internal memory about 2 GB. One time per hour the data are sent via GPS to an Internet-based Server data base. Eco-Alliance ensures regular back up's and archiving. The data can be read any time from the internet data base by authorised personnel. The utilised methane amount is automatically calculated and stored in the PLC. As all input data are stored, the automatically calculation can be checked in retrospect any time.

Data from the flare and the cogeneration unit are collected, processed and stored using a Siemens SIMATIC PLC S7 system and Siemens WINCC programming software. All data is stored in the internal memory about 2 GB. The data are read daily by Kuhse GmbH via GPS and stored in the Kuhse database in Germany. The data can be viewed any time using special access software provided by Kuhse. Kuhse ensures regular back ups and archiving. The data are regularly reviewed by Carbon-TF and Eco-Alliance OOO. Carbon-TF provides regularly storing and archiving of the data as well as regularly transfer to Excel sheets for analysis, evaluation and reporting procedures.

The data can be read any time from the Kuhse data base by authorised personnel. The utilised methane amount is automatically calculated and stored in the PLC. As all input data are stored, the automatically calculation can be checked in retrospect any time.

For plausibility checks and potential data back up, data recorded by coal mine personnel in hand written journals can be taken. The journals are stored by the coal mine.

B.4. Special event log:

The production of the flare has significantly lowered since November 2009.

Starting with the winter 2009/2010 the available utilisable CMM amount has significantly fallen down. The reason is a change to a new coal seam, which has surprisingly only very low CH₄ concentration. Consequently the CH₄-utilisation decreased. Finally the flare has been shut down at 23/10/2010 due to lacking gas amount and has been moved to another JI project of the project owner, to the Coal Mine Nr.22 Kommunarskaya, JI0078, at 29/10/2010.

From 01/04/2010 to 20/04/2010 no plausible data have been recorded for the CMM flow amount of the CHP unit. The pressure difference meter of the CHP was malfunctioning. For simplification the CH₄ flow data for the complete month April have been recalculated using the produced power amount.

On 19/04/2010 works on transferring of the monitoring system for summer boilers have started and on 26/04/2010 the monitoring system has been shut down for adjustment until 06/06/2010 when the works on transferring have been finished. During the period the emissions weren't taken into account.

SECTION C. Quality assurance and quality control measures

C.1. Documented procedures and management plan:

C.1.1. Roles and responsibilities:

The general project management is implemented by the Technical Director of Shakhtoupravlenye Donbass, the Holding Company of the Shcheglovskaya-Glubokaya Coal Mine, through supervision and coordination of activities of his subordinates, such as deputy director on surface degasification, heat technician, and heads of safety engineering departments.

Daily a group of mechanics and electricians who are responsible for the measures and maintenance of all technological equipment and measuring instruments are present on-site. There are two shifts, 12 h each. For every shift there is one person on-duty responsible for the proper operation and keeping of the journals.

Overview calculations about the methane amount utilised are made on a monthly and yearly basis and notified in the journal. The monitoring system is supervised by the administration of the coal mine under the existing control and reporting system. The general supervision of the new electronically monitoring system is executed by Eco-Alliance OOO, who is consultant for the coal mine

C.1.2. Trainings:

The employees responsible for the monitoring control have been trained on-the-job during the installation of the system.

The responsible personnel of Eco-Alliance has been trained on the handling with CMM-utilisation units and the applied monitoring systems, during an eight week long practical course in Germany in the autumn of 2005 and a two-week practical course in August/September 2008. In this courses which has been carried out by A-TEC Anlagentechnik GmbH, a Joint-Venture participant of Eco-Alliance, also the basic principles of emissions trading and the background of the monitoring has been explained. A-TEC Anlagentechnik GmbH is already running several CMM utilisation plants and monitoring systems in Germany.

These trained personnel is the basis of a team of engineers, which should establish a specialised service team in the Ukraine and instruct further operating and monitoring personnel, as well for this project.

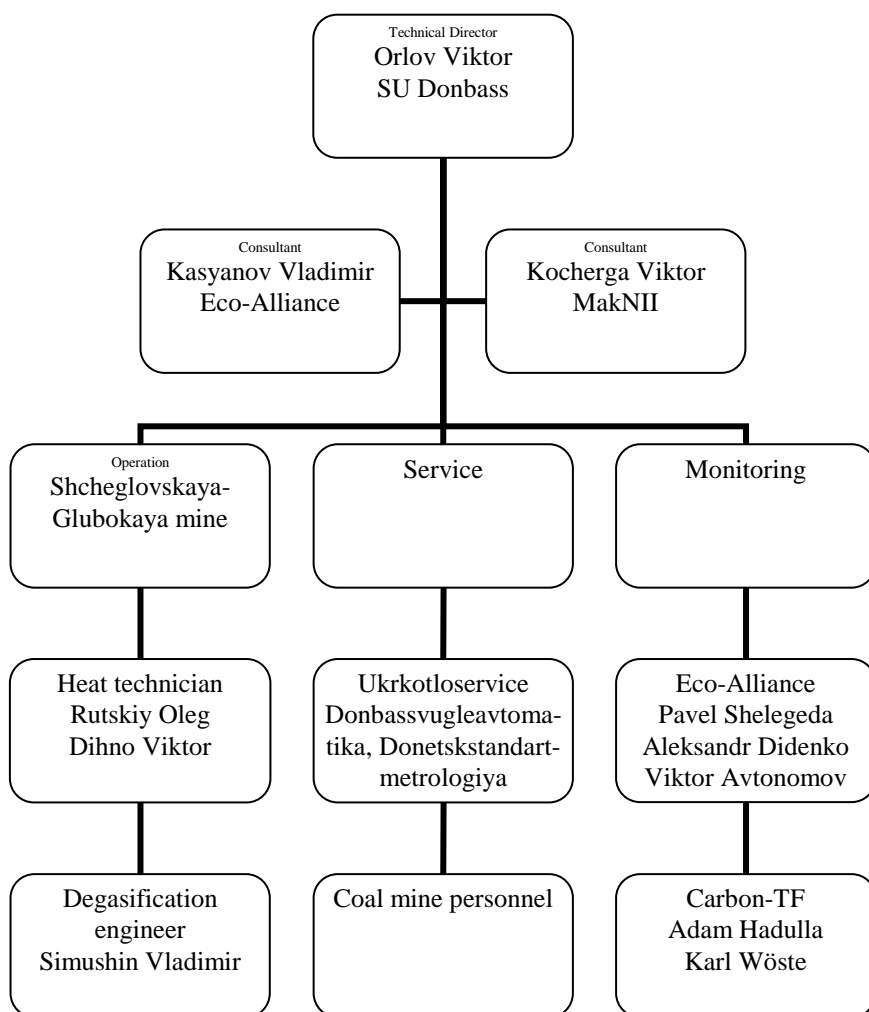

Figure 1 – Organigram

C.2. Involvement of Third Parties:

- MakNII Institute, the “State Makeyevka Institute for Research and Education for Safe Work in the Coal Mining Industry”, a subsidiary of the “Ukrainian Ministry for Fuel and Energy”, has been involved for the lab analysis (NMHC) of the CMM.
- Ukrkotloservis has been involved for the service of the boiler.
- Donbasvugleavtomatyka OOO has been involved for the regular calibrations and service of the measurement and control equipment of the boilers and VAH.
- Sumystandardmetrologiya has been involved for the regular calibrations and service of the monitoring devices

C.3. Internal audits and control measures:

Methane concentration and CMM flow data of the flares are compared with the indication of the meters from the vacuum pump station for plausibility. The coal mine personnel have been instructed by Eco-Alliance.

QM procedure:

- Electronic data are stored at Eco-Alliance and Carbon-TF.
- Back-ups are made regularly by Eco-Alliance and Carbon-TF.
- A monitoring engineer from Eco-Alliance checks the data from web-site every day and makes internal weekly reports.
- Eco Alliance prepares monthly reports which are checked by Carbon-TF B.V.
- Carbon-TF prepares the monitoring report, which is checked by Eco-Alliance and the coal mine.
- Additionally data are recorded manually in journals by the coal mine personnel
- The journals are checked daily by the chief heat technician and cross-checked monthly by Eco Alliance OOO
- The paper data are stored at the coal mine.
- Every 2 weeks a monitoring engineer from Eco-Alliance makes audits and remarks this in the operation journal.
- The mechanic on duty from the coal mine makes daily audits.
- Eco-Alliance makes service audits every month.

C.4. Troubleshooting procedures:

The general troubleshooting procedures for the boilers and the VAH are available at the coal mine. The coal mine personnel are instructed to follow the procedures.

In case of disturbance the gas supply to the boiler is shut down by a quick acting valve and the CMM supplied by the degasification system of the coal mine is blown to the atmosphere. The flare and the cogeneration unit are also automatically shut down in case of faults.

SECTION D. Calculation of GHG emission reductions

D.1. Table providing the formulas used:

Table - 10 Formulae used taken from the revised Monitoring Plan

ID number	Data variable	Nr.	Formula
P1 PE	Project emissions	(1)	$PE = PE_{ME} + PE_{MD} + PE_{UM}$
P2 PE _{ME}	Project emissions from energy use to capture and use methane	(2)	$PE_{ME} = CONS_{ELEC,PJ} \times CEF_{ELEC,PJ}$
P3 PE _{MD}	Project emissions from methane destroyed	(3)	$PE_{MD} = (MD_{FL} + MD_{ELEC} + MD_{HEAT}) \times (CEF_{CH4} + r \times CEF_{NMHC})$
P4 PE _{UM}	Project emissions from uncombusted methane	(9)	$PE_{UM} = GWP_{CH4} \times [MM_{ELEC} \times (1 - Eff_{ELEC}) + MM_{HEAT} \times (1 - Eff_{HEAT})] + PE_{Flare}$
P5 CONS _{ELEC,PJ}	Additional electricity consumption by project	(31)	$CONS_{ELEC} = GEN_{CHP} * 0.035$
PE _{Flare}	Project emissions from flaring	(9a)	$PE_{Flare} = (MM_{F1} - MD_{F1}) \times GWP_{CH4}$
P11 MD _{FL}	Methane destroyed by flaring	(5)	$MD_{FL} = \sum_{i=1}^n MM_{FL,i} \times \eta_{flare,i}$
P14 MD _{ELEC}	Methane destroyed by power generation	(6)	$MD_{ELEC} = MM_{ELEC} \times Eff_{ELEC}$
P15 MM _{ELEC}	Methane sent to power generation	(6a)	$MM_{ELEC} = MM_{CHP} + MM_{EPG}$
P17 MD _{HEAT}	Methane destroyed by heat generation	(7)	$MD_{HEAT} = MM_{HEAT} \times Eff_{HEAT}$
P18 MM _{HEAT}	Methane sent to heat generation	(7a)	$MM_{HEAT} = MM_{WBOIL} + MM_{SBOIL} + MM_{VAH}$
P27 r	Relative proportion of NMHC compared to methane	(4)	$r = PC_{NMHC} / PC_{CH4}$
B1 BE	Baseline emissions	(10)	$BE = BE_{MR} + BE_{Use}$
B3 BE _{MR}	Baseline emissions from release of methane into the atmosphere that is avoided by the project activity	(14)	$BE_{MR} = CMM_{PJ} \times GWP_{CH4}$
B4 BE _{Use}	Baseline emissions from the production of power, heat or supply to gas grid replaced by the project activity	(24)	$BE_{Use} = GEN \times EF_{ELEC} + (HEAT / Eff_{COAL}) \times EF_{HEAT}$
B14 CMM _{PJ}	CMM captured in the project activity	(14a)	$CMM_{PJ} = MM_{FL} + MM_{ELEC} + MM_{HEAT}$

MONITORING REPORT FORM

B46 GEN	Electricity generation by project	(27)	$GEN = GEN_{CHP} + GEN_{EPG}$
GEN _{EPG}	Electricity generation by emergency power generator	(28)	$GEN_{EPG} = MM_{EPG} \times Eff_{ELEC} \times Eff_{EPG} \times HV_{CH_4}$
B47 HEAT	Heat generation by project	(25)	$HEAT = HEAT_{WBoil} + HEAT_{SBoil} + HEAT_{VAH}$
HEAT _{VAH}	Heat generation by VAH	(26)	$HEAT_{VAH} = MM_{VAH} \times Eff_{HEAT} \times Eff_{VAH} \times HV_{CH_4}$
ER	Emission reductions	(18)	$ER = BE - PE$
MM _{CHP}	Methane sent to cogeneration unit	(29)	$MM_{CHP} = \frac{GEN_{CHP}}{Eff_{ELEC} \times HV_{CH_4}}$
Eff _{CHP}	efficiency of power generation in cogeneration unit	(30)	$Eff_{CHP} = \frac{GEN_{CHP}}{MM_{CHP} \times HV_{CH_4}}$

MONITORING REPORT FORM

D.2. Description and consideration of measurement uncertainties and error propagation:

Some minor errors which have been identified in hand written operation journals have been corrected. Mistakes were made during the writing the DATA from the monitor into journals. During checking the DATA, the monitoring engineer has made adjustments to the time of measurement, namely: record the exact time (hours and minutes).

D.3. GHG emission reductions (referring to B.2. of this document):

D.3.1. Comparison:

Period	Prospected emission reductions, PDD [t CO _{2eq}]		Monitored emission reductions [t CO _{2eq}]	
	Full year	Proportionally for the monitoring period	in tonnes and percentage of prospected emissions	
01/04/2010-31/12/2010	172,692 (2010)	129,519	52,227	40.3%
01/01/2011-15/03/2011	172,555 (2011)	35,949	15,198	42.2%
Total 2010-2011		165,468	67,425	40.7%

The monitored values are significantly lower than the prospected values, because of the lower gas amount produced by the coal mine. See A.3. for justification.

D.3.2 Monitored project emissions

Monitored project emissions [t CO _{2eq} / a]			
period	01/04/2010-31/12/2010	01/01/2011-15/03/2011	Total 2010-2011
methane destruction			
flaring	1,783	0	1,783
heat generation	2,913	1,999	4,912
power generation	2,744	2	2,746
additional power consumption			
power generation	157	0	157
Total	7,597	2,001	9,598

MONITORING REPORT FORM

D.3.3 Monitored baseline emissions

Monitored baseline emissions [t CO2eq / a]			
period	01/04/2010-31/12/2010	01/01/2011-15/03/2011	Total 2010-2011
release of methane that is avoided by the project			
flaring	12,108	0	12,108
heat generation	21,533	14,777	36,310
power generation	20,281	13	20,294
production of heat that is displaced by the project	1,418	2,406	3,824
production of power that is displaced by the project	4,484	3	4,487
Total	59,824	17,199	77,023

D.3.4

Table E-6 – Project emissions and emission reductions during the 2st verification period

period	Monitored project emissions (tonnes of CO2 equivalent)	Monitored leakage (tonnes of CO2 equivalent)	Monitored baseline emissions (tonnes of CO2 equivalent)	Monitored emissions reductions (tonnes of CO2 equivalent)
01/04/2010-31/12/2010	7,597	-	59,824	52,227
01/01/2011-15/03/2011	2,001	-	17,199	15,198
Total (tonnes of CO2 equivalent)	9,598	-	77,023	67,425

Annex 1**REFERENCES**

- [PDD], Project Design Document; Version 07, dated 2009-08-06
- [IPCC], Revised 1996 IPCC Guidelines for National Greenhouse Gas Inventories, Reference Manual (Volume 3), Chapter Energy, 1.4.1 Unoxidized Carbon, Page 1.32, 1996, <http://www.ipcc-nggip.iges.or.jp/public/gl/invs6a.htm>
- [IPCC-2], IPCC - Terms of Reference, Chapter1, Introduction, Source of Categories, Table 1.2
- [ACM0008], Approved consolidated baseline methodology ACM0008 – Consolidated baseline methodology for coal bed methane and coal mine methane capture and use for power (electrical or motive) and heat and/or destruction by flaring, version 03, EB28
<http://cdm.unfccc.int/methodologies/PAmethodologies/approved.html>
- [AM_Tool_07], Methodological “Tool to determine project emissions from flaring gases containing methane”, EB 28, Meeting report, Annex 13
- Final Determination Report for the project: JI0077 CMM utilisation on the coal mine Shcheglovskaya-Glubokaya of the State Holding Joint-Stock Company „GOAO Shakhtoupravlenye Donbass“ Report No: 2008-1321 Rev 02, by DNV Det Norske Veritas, dated 2009-08-07
- The project is approved as JI-project since 08/12/2009
(http://ji.unfccc.int/JI_Projects/DeterAndVerif/Verification/FinDet.html)
Registration numbers UA2000015, JI0077
- Letter of Approval, Nr. M000015, issued on 2008-03-26 by the Ukraine (host party)
- Letter of Approval, Nr. 2008JI04, issued on 2008-04-22 by the Kingdom of the Netherlands (investor party)
- Determination and verification manual (version 01), undated
<http://ji.unfccc.int/Ref/Guida/index.html>
- further supporting evidence documents provided by the coal mine

Annex 3

Energy and material flowchart including metering positions

The electronically data storage system is fully in operation. Manual records (journals) are still used by the coal mine and can be taken for backup.

The heat produced by the VAH and the power produced by the emergency power generator are not recorded with meters but calculated using the utilised methane amount.

Two additional CH4 meters are installed in the central suction system. The measurements results are recorded in hand written journals and can be taken as plausibility measurement.

The general installation scheme is given in Figure-3. The ID's given in Figure-3 are corresponding to the ID's in Table-5.

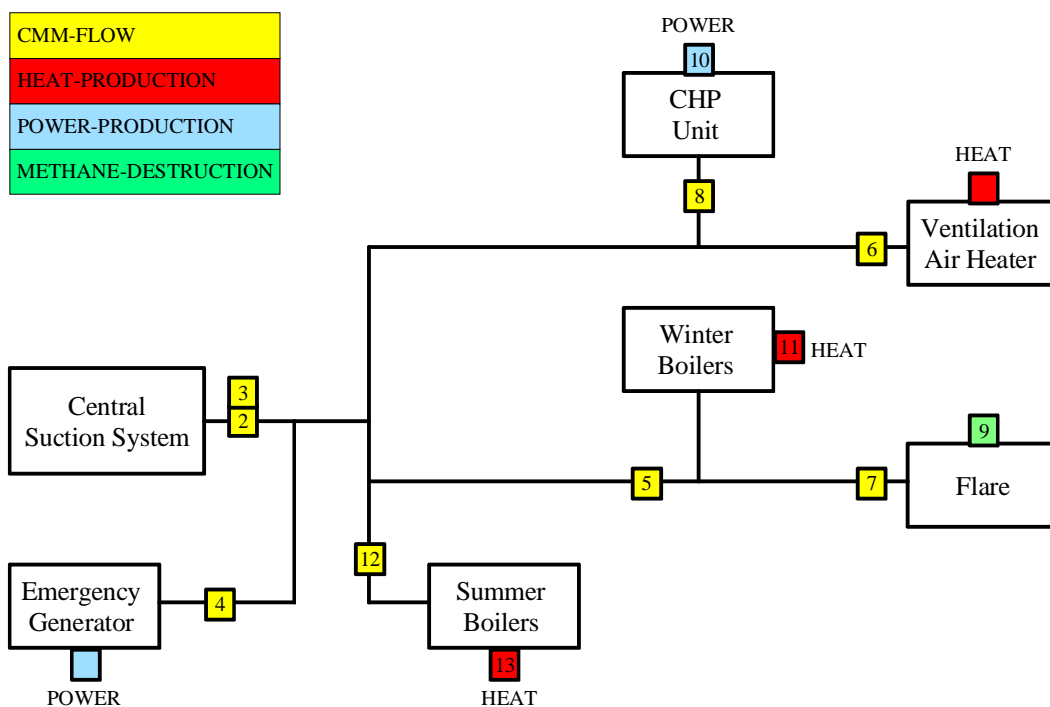

Figure-3 Installation scheme and positioning of the meters

The flare and the cogeneration unit have been equipped with an similar electronically monitoring system. The monitoring plan applied during the monitoring period is according to the PDD. See Figure-4

CMM from central suction system

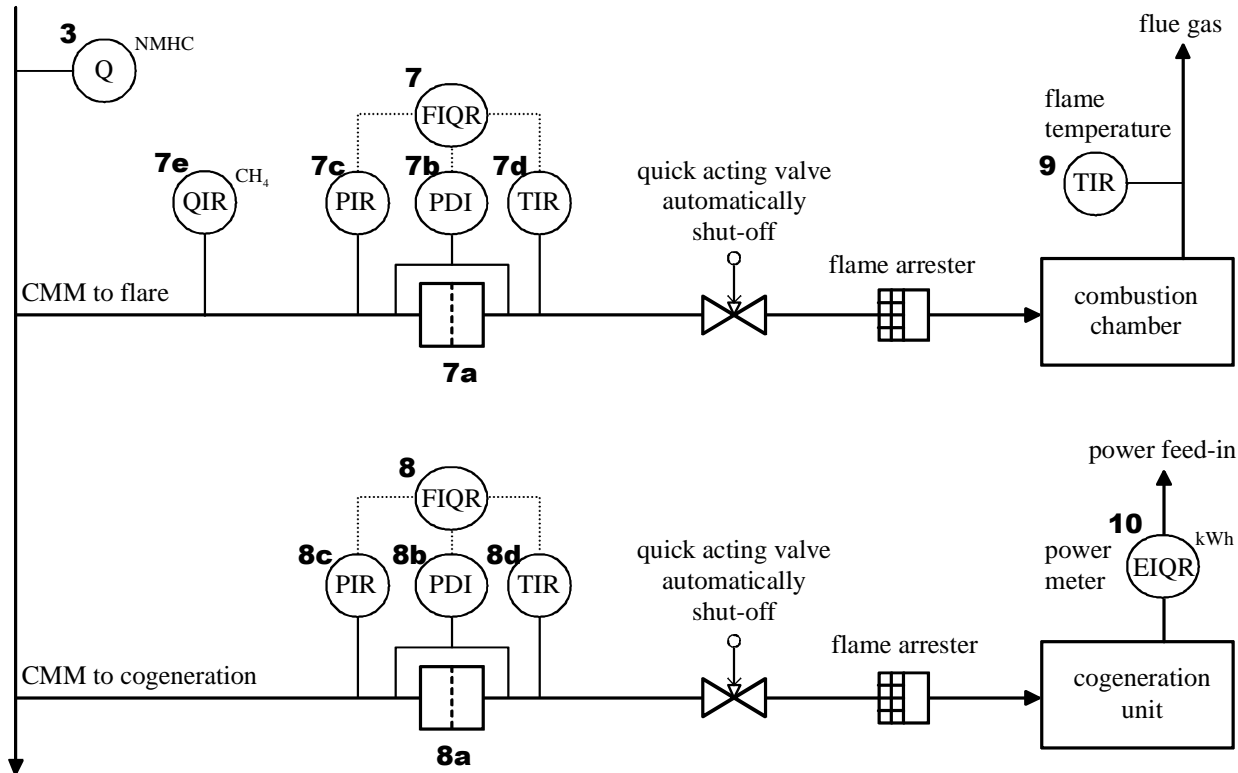

Figure -4 Installation scheme and positioning of the meters, flare and CHP

CMM from central suction system

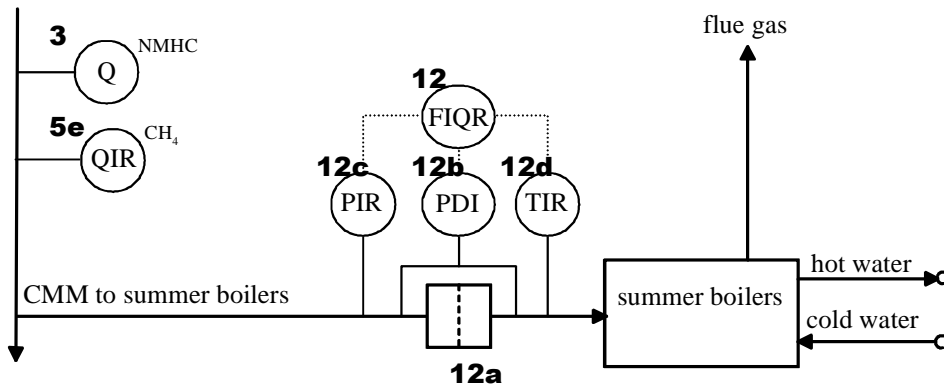

Figure -5 Installation scheme and positioning of the meters, summer boilers

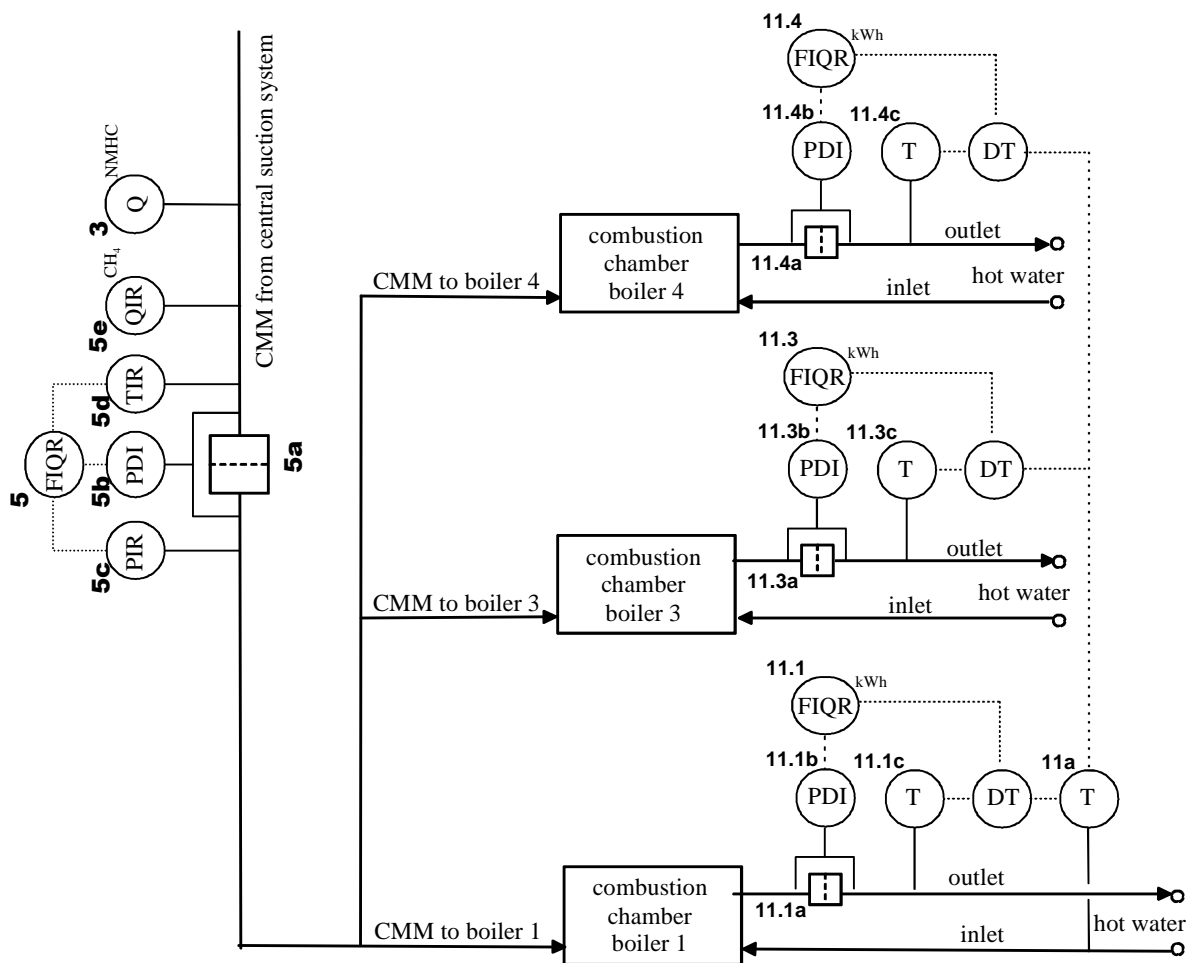

Figure -6 Installation scheme and positioning of the meters, winter boilers 1, 3 and 4

Annex 4

Deviation from the monitoring plan as stated in the PDD

A4.1 Project emissions from flaring

The formula for the calculation of project emissions from uncombusted methane has been updated. The calculation of project emissions from uncombusted methane from flaring are now more accurate.

In the PDD the formula for project emissions from uncombusted methane is given as per:

$$PE_{UM} = GWP_{CH_4} \times [(MM_{FL} \times (1 - Eff_{FL}) + MM_{ELEC} \times (1 - Eff_{ELEC}) + MM_{HEAT} \times (1 - Eff_{HEAT}))] \quad (9) \text{ old}$$

In the revised monitoring plan the formula (9) has been replaced by the following formula:

$$PE_{UM} = GWP_{CH_4} \times [MM_{ELEC} \times (1 - Eff_{ELEC}) + MM_{HEAT} \times (1 - Eff_{HEAT})] + PE_{flare} \quad (9) \text{ new}$$

PE_{flare} is calculated using adopted formulae from the «Methodological “Tool to determine project emissions from flaring gases containing methane”» [AM_Tool_07] and ACM0008 Version 5. The original formulae refers to a yearly basis. The formulae have been adapted in the revised monitoring plan to variable monitoring periods:

The original formulae are:

$$PE_{flare} = \sum_{i=1}^n TM_{RG,i} \times (1 - \eta_{flare,i}) \times \frac{GWP_{CH_4}}{1000} \quad (9a)$$

where:

- PE_{flare} Project emissions from flaring in the regarded period (t CO₂eq)
- $TM_{RG,i}$ Mass flow rate of methane in the regarded interval i (kg/interval)
- $\eta_{flare,i}$ flare efficiency in the interval i
- GWP_{CH_4} Global warming potential of methane (21 tCO₂eq/tCH₄)
- n number of samples (intervals) in the regarded period

and

$$MD_{FL} = MM_{FL} - (PE_{flare}/GWP_{CH_4}) \quad (5)$$

where:

- MD_{FL} Methane destroyed through flaring in the regarded period (t CH₄)
- MM_{FL} Methane sent to flaring in the regarded period (t CH₄)
- PE_{flare} Project emissions from flaring in the regarded period (t CO₂eq)
- GWP_{CH_4} Global warming potential of methane (21 tCO₂eq/tCH₄)

In the revised monitoring plan and this monitoring report, formulae 9a and 5, see above have been resolved to fit better to the monitored data.

The project emissions from flaring are calculated using the equation:

$$PE_{flare} = (MM_{FI} - MD_{FL}) * GWP_{CH_4} \quad (9a)$$

where:

- PE_{flare} Project emissions from flaring in the regarded period (t CO₂eq)

MD_{ELEC} Methane destroyed through power generation (t CH₄)
 MM_{ELEC} Methane measured sent to power plant (t CH₄)
 GWP_{CH4} Global warming potential of methane (21 tCO₂eq/tCH₄)

The formula for the methane destroyed through flaring is:

$$MD_{FL} = \sum_{i=1}^n MM_{FL,i} \times \eta_{flare,i} \quad (5)$$

where:

MD_{FL} Methane destroyed through flaring (t CH₄)
 MM_{FL,i} Methane sent to flaring in the interval i (t CH₄)
 $\eta_{flare,i}$ Efficiency of methane destruction/oxidation in flare in the interval i, see below
 n number of samples (intervals) in the regarded period

The interval is set to 15 min during the monitoring period, which is more accurate than the 1 h intervals from the «Methodological “Tool to determine project emissions from flaring gases containing methane”» [AM_Tool_07])

For $\eta_{flare,i}$ three different values are taken, depending on the current combustion temperature T_{Flame,i} of the flare in the interval i:

T _{Flame,i}	$\eta_{flare,i}$	Source
> 850°C	99.5%	[PDD, revised monitoring plan Section D.1.1 and Annex 3]
500-850°C	90.0%	[AM_Tool_07-15]
< 500°C	0%	[AM_Tool_07-15]

where:

T_{Flame,i} Flame temperature of the flare in the regarded interval i (°C)
 $\eta_{flare,i}$ flare efficiency in the interval i

A.4.2 Cogeneration unit

The power amount of the cogeneration is counted a mechanical counter (NZR). Daily readings are recorded manually in a journal. There is also an electronically power rating meter (KMU) built-in in the cogeneration engine. For the determination of the power amount produced the electronically recorded values are taken (KMU). The difference between the both power meters is negligible.

During the first month of the monitoring period (April 2010), the data acquisition system was disturbed, so that no reasonable electronically data for power production (KMU) and methane amount consumed by the unit are available. For this period manually recorded data from the NZR journal have been taken for the power production.

The methane amount utilised in April 2010 has been recalculated using the produced power amount (NZR) and the average power generation efficiency determined from the later steady operation period.

$$MM_{CHP} = \frac{GEN_{CHP}}{Eff_{ELEC} \times HV_{CH4}} \quad (29)$$

with

MM_{CHP} Methane amount utilised by the cogeneration unit in the specific period [t CH₄]
 GEN_{CHP} Electricity produced by the project [MWh]
 Eff_{CHP} efficiency of power generation [%] recalculated from later steady operation period
 HV_{CH4} heating value of methane [9.965 kWh/m³, equal to 13.899 MWh/t]

The efficiency of power generation in the cogeneration unit is recalculated from later steady operation period:

$$Eff_{CHP} = \frac{GEN_{CHP}}{MM_{CHP} \times HV_{CH4}} \quad (30)$$

with

Eff_{CHP} efficiency of power generation
 GEN_{CHP} Electricity produced by the project in the specific period [MWh]
 MM_{CHP} Methane amount utilised by the cogeneration unit in the specific period [t CH₄]
 HV_{CH4} heating value of methane [9.965 kWh/m³, equal to 13.899 MWh/t]

The cogeneration unit needs additional power especially for the cooling fans. The power amount consumed by the power generation units is taken into account as $CONS_{ELEC,PJ}$. The additional energy is not measured with power meters, but calculated using a fixed percentage of the produced power. The percentage has been fixed to 3.5% based on experience made with more than 120 cogeneration units in Germany.

$$CONS_{ELEC} = GEN_{CHP} * 0.035 \quad (31)$$

A.4.3 Emergency Power Cogeneration unit

The power amount of the emergency power generator has not been counted. The electricity production has been recalculated using the methane amount consumed by the unit and the power efficiency as given in the PDD.

$$GEN_{EPG} = MM_{EPG} \times Eff_{ELEC} \times Eff_{EPG} \times HV_{CH4} \quad (28)$$

with

GEN_{EPG} electricity produced by the project [MWh]
 MM_{EPG} methane amount sent to emergency power generation, measured with flow meter [t CH₄]
 Eff_{ELEC} efficiency of methane destruction/oxidisation in power plant, set to 99.5% (ACM0008/IPCC)
 Eff_{EPG} efficiency of emergency power generation; set to 36% as given in the PDD
 HV_{CH4} heating value of methane [9.965 kWh/m³, equal to 13.899 MWh/t]

A4.4 Heat generation by summer boilers and VAH

The heat amount produced by the VAH has not been measured but calculated using the utilised CH₄ amount and the VAH efficiency.

$$\text{HEAT}_{\text{VAH}} = \text{MM}_{\text{VAH}} \times \text{Eff}_{\text{HEAT}} \times \text{Eff}_{\text{VAH}} \times \text{HV}_{\text{CH}_4} \quad (25)$$

with

HEAT_{VAH}	heat generated by the ventilation air heater [MWh]
MM_{VAH}	methane amount sent to ventilation air heater [t CH ₄]
Eff_{HEAT}	Efficiency of methane destruction/oxidation in heat plant (take as 99.5% from ACM0008/IPCC)
Eff_{VAH}	efficiency of heat production in ventilation air heater; set to 97.25%
HV_{CH_4}	heating value of methane [9.965 kWh/m ³ , equal to 13.899 MWh/t]

Annex 5**Differences between the determined PDD and implemented project**

There are some differences between the determined PDD and implemented project. The conditions defined by paragraph 33 of the JI guidelines are still met for the project.

- The physical location of the project has not changed.
- The emission sources have not changed.
- The baseline scenario has not changed.
- The changes are consistent with the JI specific approach and/or the clean development mechanism (CDM) methodology upon which the determination was prepared for the project.

The differences of the project installation as described in the PDD and the implemented project are listed in the table below.

unit	Difference	justification
Winter boilers No: 1, 3 & 4	missing monitoring system	The installation of the monitoring system was delayed due to lacking funds and has been completed in February 2010.
Summer boilers No: 1 & 2	missing monitoring system	The installation of the monitoring system was delayed due to lacking funds and has been completed in June 2010.
flare No: 1	changed firing capacity 10 MW instead of 5 MW	In the PDD a flaring capacity of 5 MW was given. The installed flare has originally a capacity of up to 8.525 MW and has been slightly modified to reach an extended capacity of up to 10 MW. This allowed a higher utilisation of CH ₄ in the beginning of the project while the installation of the other units was delayed. The flare has shut down production in October 2010 and has been moved to the JI-Project Coal Mine Nr.22 Kommunarskaya in November 2010 of the same project owner, due to lacking gas amount.
flare No: 2	delay / pending	The installation of the second was delayed due to lacking funds due to delayed project registration. The installation is now pending due to lacking gas amount.
ventilation air heater	missing monitoring system	The installation of the monitoring system was delayed due to lacking funds and has been completed in February 2010.

Annex 6**History of the Document**

Version	Date	Nature of Revision
1	8 March 2011	Initial adoption
2	1 April 2011	Updated version
3	21 April 2011	Revised version
4	12 May 2011	Revised version
5	19 May 2011	Revised version