



JOINT IMPLEMENTATION PROJECT DESIGN DOCUMENT FORM
Version 01 – in effect as of: 15 June 2006

CONTENTS

- A. General description of the project
- B. Baseline
- C. Duration of the project / crediting period
- D. Monitoring plan
- E. Estimation of greenhouse gas emission reductions
- F. Environmental impacts
- G. Stakeholders' comments

Annexes

Annex 1: Contact information on project participants

Annex 2: Baseline information

Annex 3: Monitoring plan

**SECTION A. General description of the project****A.1. Title of the project:****Reduction of greenhouse gases emissions by gasification of Ivano-Frankivsk region**

Sectoral scope:

Sector 3 – Energy demand

PDD Version: 02

Date: 10/10/2012

A.2. Description of the project:*The main goals of project activity.*

The main purpose of the project is reduction of greenhouse gas emissions by changing the structure of fuel consumption in industrial, utility, administrative and private sectors by replacing solid and liquid fuels with natural gas. The project provides for the construction and expansion of gas distribution systems (GDS), which will also improve the energy efficiency of thermal power generation due to the transition of existing heating systems to natural gas. The Project that is initiated by PJSC “Ivano-Frankivskgas” will result in the reduction of greenhouse gas emissions into the atmosphere and will improve the environmental situation in the region.

Short description of the company.

The main type of activity of PJSC “Ivano-Frankivskgas” is natural gas distribution, transportation and supply. One of the main objectives of the enterprise is uninterrupted and safe gas provision of consumers in Ivano-Frankivsk region, as well as implementation of advanced solutions for the economical use of natural gas. For the implementation of the above, special attention is paid to the improvement of quality of maintenance of gas supply systems, timely overhaul thereof, gas pipelines protection from electrochemical corrosion and other damage. The Company uses modern reliable technologies of well-known national and foreign producers in order to ensure stable and safe operation of the gas supply system and to maintain the desired working gas pressure. However, the structure of existing tariffs for gas transportation regulated by the state does not take into consideration amortization and investment needs of gas distribution companies. This hinders the flow of sufficient funds for the purposes of repair, modernization and development of gas networks, procurement of appropriate technological equipment and components.

Code in the Unified State Register of Enterprises and Organizations of Ukraine – 03361046

Name of activities under the Foreign-Economic Activities Code: 40.22.0 Gas distribution and supply; 45.33.3 Gas pipeline works; 45.21.4 Construction of local pipelines, communication lines and power supply.

The situation existing prior to the project activity

Prior to the proposed project construction of gas networks didn't take place. All funds were spent on maintaining the company's gas distribution system in operation, eliminating local damage and repair. This hampered the development of natural gas supply system, and therefore the transition of consumers from the use of solid and liquid fuels to natural gas.



The baseline scenario.

Therefore the most plausible baseline scenario, which can continue to operate energy complex, is to continue operating the existing systems of transportation and preparation of energy carrier as well as heat supply systems that would result in the use by the end consumers of less environment-friendly fuel (fuel oil, coal), which would generate a significant amount of greenhouse gases (GHG) when combusted. In addition, the continued operation of obsolete equipment (most of which was produced in the USSR) and, consequently, low efficiency of transportation system and energy consumption system would lead to excessive use of fossil fuel that would have negative impact on the atmosphere because of GHG emissions.

Project scenario.

The project scenario involves expansion of the territorial gas supply system, which includes construction and reconstruction of gas distribution networks (GDN) and related equipment. The project provides for modernization of the fuel consumption system by means of transition of heating systems to natural gas and transferring the consumers from centralized to individual heating and hot water supply systems, which, in turn, would lead to the use of more efficient and environment-friendly fossil fuel (natural gas), improvement of the quality of heating and hot water supply services, reduction of thermal energy consumption due to increased efficiency of individual systems in comparison with the centralized ones.

In general, the project activity is aimed at:

- ensuring the supply of gas fuel (natural gas) to end users by means of construction and reconstruction of gas distribution networks (gasification);
- replacement of solid and liquid fuels with natural gas;
- increase in thermal energy efficiency;
- reduction of greenhouse gas emission under the Joint Implementation (JI) Mechanism.

The project implementation will be carried out in three main sectors: industrial, social and administrative. Nowadays, natural gas does not enjoy strong demand. First of all, this is due to the lack of an extensive gas distribution network that would meet fuel demand of consumers of industrial, social (household) and administrative sectors.

First of all, the gasification project provides for the construction of the main pipeline system for gasification of consumers of industrial and energy sectors. The project further provides for gasification of consumers in household, administrative and commercial sectors and a gradual transition of households to gas fuel. For gasification of new territories, new gas distribution networks will be developed and built. This will expand the national gas distribution network.

History of the project activity

26/09/2003 – PJSC “Ivano-Frankivskgas” started activities on gas distribution network expansion within the framework of the Joint Implementation Project “Reduction of greenhouse gases emissions by gasification of Ivano-Frankivsk region”.

30/08/2012 – supporting materials on the project of anthropogenic GHG emission reduction were submitted to the State Environmental Investment Agency of Ukraine.



04/10/2012 - the State Environmental Investment Agency of Ukraine issued a Letter of Endorsement No.2889/23/7 for the Jl project "Reduction of greenhouse gases emissions by gasification of Ivano-Frankivsk region".

A.3. Project participants:

<u>Party involved</u> *	<u>Legal entity project participant</u> (as applicable)	Please indicate if the <u>Party involved</u> wishes to be considered as <u>project participant</u> (Yes/No)
Ukraine (Host Party)	<ul style="list-style-type: none"> PJSC "Ivano-Frankivskgas" 	No
Switzerland	<ul style="list-style-type: none"> CEP CARBON EMISSIONS PARTNERS S.A 	No

*Please indicate if the Party involved is a Host Party.

The Developer's company will be the official project owner and managing entity and the responsible body for all administrative affairs of the involved parties in Host and Investor Countries.

Information on the organization, that is a potential ERUs purchaser is provided in Annex 1.

A.4. Technical description of the project:

A.4.1. Location of the project:

The project is located in the Ivano-Frankivsk region in southwestern Ukraine, the area bordered by the Zakarpattia, Lviv, Ternopil and Chernivtsi regions. The regional center of Ivano-Frankivsk - Ivano-Frankivsk.

A.4.1.1. Host Party(ies):

The project is located in Ukraine.

Ukraine is an Eastern European country that ratified the Kyoto Protocol to the UN Framework Convention on Climate Change on February 4, 2004¹. It is listed in the Annex 1 and meets the requirements of participation in Joint Implementation projects².

A.4.1.2. Region/State/Province etc.:

The project is located in the territory of Ivano-Frankivsk region.

A.4.1.3. City/Town/Community etc.:

The project encompasses Ivano-Frankivsk region.

¹ <http://zakon.rada.gov.ua/cgi-bin/laws/main.cgi?nreg=1430-15>

² http://zakon.rada.gov.ua/cgi-bin/laws/main.cgi?page=1&nreg=995_801

A.4.1.4. Detail of physical location, including information allowing the unique identification of the project (maximum one page):

The project is implemented in the territory of Ivano-Frankivsk region (24.693241 N, 48.92315 E - the coordinates of PJSC “Ivano-Frankivskgas” headquarters). The geographic location of the project is shown below:



Figure 1. Location of Ivano-Frankivsk region on the map of Ukraine

A.4.2. Technology(ies) to be employed, or measures, operations or actions to be implemented by the project:

Emission reductions will occur mainly due to the substitution of solid and liquid fuels with natural gas, which generates less GHG emissions.

The project “Reduction of greenhouse gases emissions by gasification of Ivano-Frankivsk region” provides for the construction of new and expansion of existing gas distribution systems (GDS), which consist of organizationally and technologically connected facilities designed to transport natural gas directly from main pipelines to individual consumers. GDSs will be developed taking into account the type of the gas source, its properties and the degree of purification, the size of the already gasified territory and its building system features, population density, number and nature of industrial and utility enterprises. Depending on the abovementioned factors GDSs, which will differ by the method of gas supply from main pipelines, the type of equipment and facilities of gas distribution networks (GDNs), communications and remote control systems, will be built. Construction and expansion of GDSs involves the construction of new GDNs using modern equipment and technology.

Gas pipelines are the main GDN element. They are classified by the gas pressure, intended use, location in relation to city planning (street, inner-block, yard and inter-workshop), location in relation to ground surface (underground, ground and aboveground) and by the material (metallic, non-metallic). Depending on the

pressure of the transported gas, pipelines are divided into: high pressure gas pipelines of category I - operating gas pressure is above 0.6 MPa (6 kgf/cm²), high pressure gas pipelines of category II - operating gas pressure is 0.3 MPa (3 kgf/cm²) - 0.6 MPa (6 kgf/cm²), mean pressure gas pipelines - operating gas pressure is 0.05 MPa (0.5 kgf/cm²) - 0.3 MPa (3 kg/cm²), low pressure gas pipelines - operating gas pressure is up to 0.05 MPa (0.5 kgf/cm²), inclusive.

Low-pressure gas pipelines are used to transport gas to residential and public buildings, catering companies, as well as to the boiler rooms and consumer services companies. Individual consumers and small heating boiler houses are also connected to low-pressure gas pipelines. Municipal high-pressure gas pipelines are the main arteries that supply natural gas to big cities. They may be executed as a dead-end schemes, where consumers get gas from only one side, or as mesh circuits, when consumers get gas from both sides of a closed circle. They deliver gas through gas distribution points (GDPs) to the medium and high pressure networks, as well as to large industrial companies, manufacturing processes of which require gas pressure of above 0.6 MPa.

For the construction of gas pipelines of high, mean and low pressure it is planned to use:

- straight seam steel welded pipes that are produced by means of electric welding of a direct joint in parallel to the axis of the tube. These pipes will be used for the construction of pipelines with operating pressure of up to 1.6 MPa. The project provides for the use of pipes of national producers, made of steel according to the standards SSTU 380-94 and SSTU 1050-88.
- polyethylene pipes of domestic production, in particular those produced by “Polimerbud” LLC³. They are designed to supply flammable gas used as raw material and fuel for industrial and public-utility use, and may be used for construction and repair of gas supply networks. The pipes are produced according to SSTU B V.2.7-73-98 “Polyethylene pipes for supplying flammable gases”⁴ made of polyethylene of PE 80 and PE 100 class, standard dimension ratio SDR 17.6 and SDR 11, nominal diameters from 20 to 400 mm. Colour of pipes is black with yellow marking stripes.

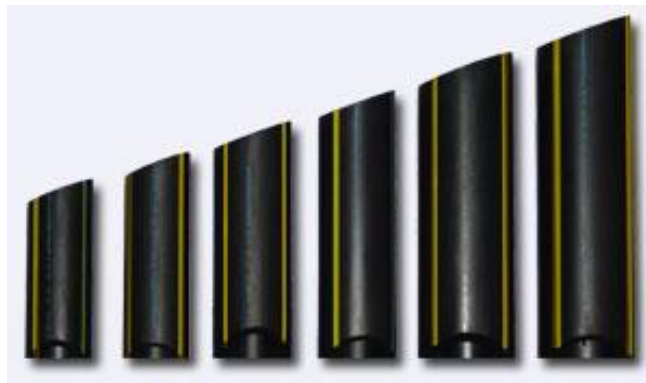

Figure 2. Appearance of polyethylene gas pipes of PE type produced by “Polimerbud” LLC

Detailed specifications of pipes manufactured by “Polimerbud” LLC as well as of connecting elements for polymer pipes can be found on the manufacturer’s web-site.^{5,6}

The choice of polyethylene pipes for the expansion of the GDS is connected with a number of their operational and technical advantages, namely:

³ http://polystroy.com/index_ukr.html

⁴ <http://www.info-build.com.ua/normativ/detail.php?ID=46127>

⁵ http://www.polimerbud.com.ua/gas_polyethylene_pipes_ukr.html

⁶ http://www.polimerbud.com.ua/soedinenie_ukr.html

- Resistance to galvanic corrosion, electrical corrosion, impacts of earth currents;
- Do not require cathodic protection and waterproofing;
- Chemical resistance to aggressive substances;
- High elasticity, ductility and breaking strength;
- Smooth inner surface (minimal flow resistance);
- High connection leak-proofness due to the polyfusion;
- Simplicity and ease of installation (no need to use sophisticated excavating equipment);
- Relatively low cost of the pipelines construction;
- Significant guaranteed lifetime (50 years).

The project provides for the use of flexible gas hose. Corrugated stainless steel tubing (CSST) and fittings (connecting elements) made of brass produced by Dong-A Flexible Metal Tubes Co., Ltd⁷ (Korea) are a reliable alternative to conventional gas pipes. This pipeline system was recognized by many countries, as well as American and Canadian Gas Associations.

Advantages of stainless technology of flexible, corrugated gas hose installation are:

- corrugated pipe is mounted by using seamless method, which means no seams and as a consequence - the safety and reliability of the pipeline. Gas leaks often occur precisely at the welding seams. In addition, all the conventional black rubber pipes tend to mummify and eventually crack. Also, welding seams are an additional resistance during transit. Since the new pipe installation technology is seamless, in case of bend the inner pipe section does not change, so resistance is minimal;
- flexible pipe is installed easily (it can take any configuration without welding, so it is indispensable when the reconstruction and construction take place, it bends without any microcracks and mechanical stress in the metal);
- installation of pipes takes a minimum of time, thus increasing labour efficiency (more work can be done per unit time)
- flexible corrugated hoses are durable (lifetime of stainless hose is 100 years, and lifetime of brass fittings is at least 50 years);
- corrugated hose combines flexibility and rigidity as to internal and external mechanical influences;
- CSSTs provide for protection from electro-mechanical processes and earth currents (due to lack of contact between the pipe and fittings);
- flexible hoses can be used for both internal and external works.



Figure 3. Corrugated stainless steel tubing produced by Dong-A Flexible Metal Tubes Co., Ltd (Korea)

⁷<http://www.dongaflexible.co.kr/english/index.asp>

Technologies of gas pipelines laying, which will be applied in the project:

- subsurface pipe-laying in trenches and impassable channels (in the soil or in constructional structures of buildings). Access to the pipes during operation is possible only after demolishing the relevant structures;
- above-ground laying of gas pipelines that may be situated on the ground or above ground at such a level so that not to impede traffic. Above-ground laying is used on country roads when crossing ravines, rivers, railways and other structures;
- trenchless construction of underground communications by using horizontal directional drilling.

Controlled horizontal drilling is a method of making horizontal wells with design parameters, continuous monitoring of the process and adjustment of the drilling route in the course of its construction with the further locking of metal and plastic pipes as well as electric cables with underground by-pass of obstacles. The main advantages of this method compared to traditional trenchless method are:

- reduction of the time for performance of work and administrative as well as technical approvals due to reduction of the volume of excavation works, works aimed at restoring the pavements, green areas, urban infrastructure, and consequently, reduction of the estimated construction cost;
- possibility to adjust the route in the process of work;
- minimization of anthropogenic impact on the environment;
- possibility to carry out works under water bodies, forests, agricultural facilities, in security zones of transmission lines, main transmission pipelines, in conditions of a dense residential development, under functional railroads and highways.



Figure 4. Operation of horizontal drilling machine

The GDN element is gas fittings (latches, valves, cork taps). Latches with rising stems and non rising stems are used. The first ones are used for above-ground installations, the second ones - for underground installations. Valves are used in cases where high pressure loss can be neglected, for example, on impulse lines. Cork taps have a much lower hydraulic resistance than the valves. They are distinguished by the conical stoppers tightening, and could be nongland and gland, and by the method of connection to pipes – coupler-joined and flanged. The project provides for the use of gas fittings of the following manufacturers: EFAWA⁸, Georg Fischer Wavin Ltd⁹.

⁸ <http://www.efawa.com.pl/>

⁹ <http://www.piping.georgfischer.com/go/05CE6B90D60EB5FC0F2285EE764987EB>



Figure 5. Appearance of gas fittings (ELGEF Plus Ball Valve produced by Georg Fischer Wavin Ltd), that are planned for installation in the framework of the project “Reduction of greenhouse gases emissions by gasification of Ivano-Frankivsk region”

The project provides for the installation of cathodic protection plants produced by “Elkon”¹⁰ and “Electroobrazovatel” Ltd¹¹. The completing units of the cathodic protection plant ensure:

- Maintenance of a given load current when changing the network voltage within the range of 170V - 250V interruption of load current;
- Automatic maintenance of a given protective potential;
- Recording of time when there is a specified potential at the facility, which is protected;
- Protection against overloads and short circuits in the load circuit;
- Overvoltage protection during storms;
- Shutting off of the plant when the supply voltage decreases below 170V with automatic switch to the operating mode when the voltage is increasing;
- Automatic switching to the operating mode after the complete disappearance and the subsequent appearance of the supply voltage.

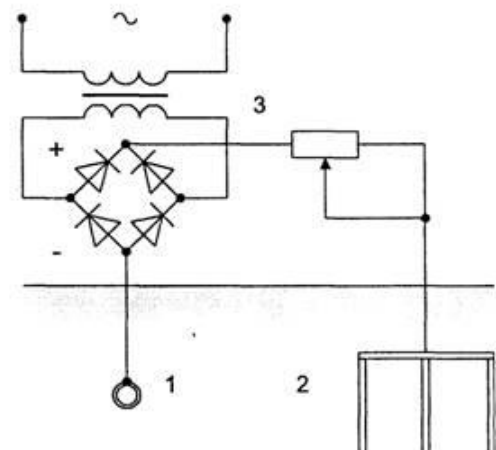

Figure 6. Appearance of a cathodic protection plant “Elkon” and basic scheme of cathodic protection: 1 – gas pipeline, 2 - anode electrode, 3 - cathodic protection station

¹⁰<http://esmatech.com.ua/>

¹¹<http://www.uralstars.com/ex/Gai/product.htm#1>

Cathodic protection plants operate on the basis of the electric transducer (CPET). CPET is designed for anti-corrosion protection of external surfaces of underground metal constructions of various purposes, in particular: pipelines and reservoirs made of carbon and low-alloy steel, main heating-,oil-,gas pipelines and their branches; compressor pipelines, gas control points and pumping plants.



Figure 7. Cathodic protection electric transducer (CPET), produced by “Elkon”.

The project provides for a geographic information system (GIS). GIS is designed to solve complex problems of exploitation and development of the gas supply system of the city. This system is based on a digital spatial model of gas networks of the capital and specialized algorithms for the hydraulic calculation of gas pipelines.

GIS will allow PJSC “Ivano-Frankivskgas” to:

- register the presence, location and characteristics of the gas network state;
- perform a quick search and navigate with the map;
- carry out information and algorithmic support for the preparation of technical conditions for connection and coordination of projects;
- analyze and display network status when connecting / disconnecting users, routine maintenance and repair works;
- select the optimal diameter of pipes in the course of designing new parts of the network.

For the remote metering of gas it is planned to install an automated gas metering system (AGMS) produced by SSPE “Electronmash”. The automated gas metering system is designed to service one or more buildings with a total number of subscribers of up to 512 for each of the buildings.

AGMS for each building has the following structure:

- Apartment meters that are connected directly to the conversion signal module (CSM);
- CSM modules, each of which can be connected to 16 gas meters;
- modules for signal conversion (SMSC), each of which can be connected to 32 CSM;
- Radio-frequency transceiver (for AGMS-1) or GSM modem (for AGMS-2) which is connected to the output of the SMPS and which represents the information output of the building;
- Computer (dispatch server), intended for collecting and processing data on gas.

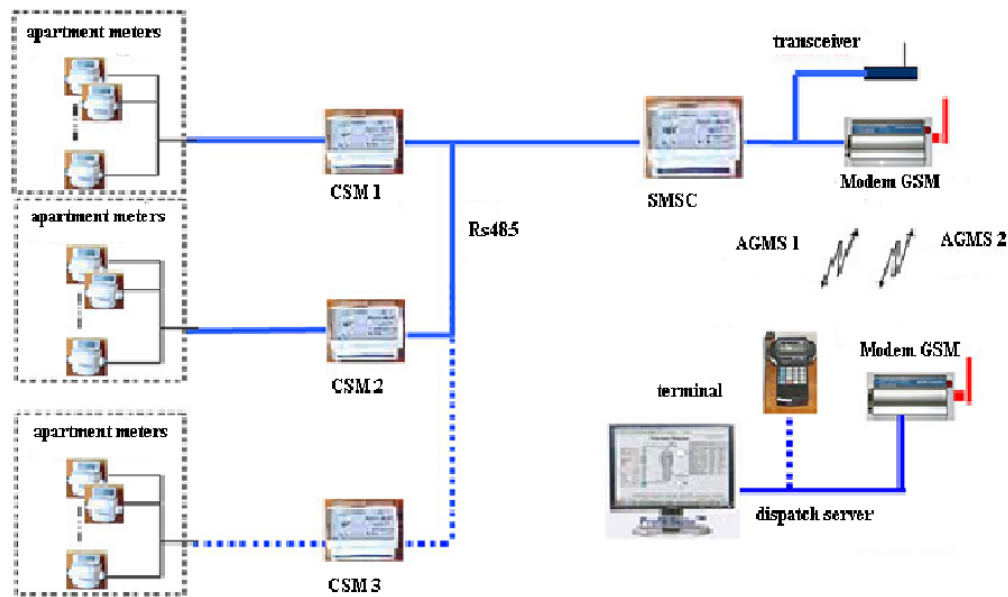

Figure 8. Scheme of the automated gas metering system

In addition to the abovementioned equipment it is planned to use the following complexes GMS-G16-40-1.0-U2-NP with a calculating machine VEGA-1-01-VB-0.5MPa-80mm (GP factory “Arsenal”¹², Kyiv), DELTA S3-FLOV G -650 with a calculator OE-22LA (“Actaris”¹³).

It is planned to buy all necessary equipment for the project from leading Ukrainian and European companies on a tender basis. During the project activity replacement of installed equipment is not planned (except for unscheduled emergency repair works) because its warranty period does not exceed the lifetime of the project.

The project provides for implementation of next milestones:

1. Construction of GDNs:
 - a. Using steel welded pipes of medium and low pressure
 - b. Using polyethylene pipes of medium and low pressure
2. Installation of means of protection from electrical and chemical corrosion
3. Installation of other GDN elements
 - a. Measuring and control gas fittings
 - b. Shut-off and control gas fittings

The major milestones of the implementation of the project “Reduction of greenhouse gases emissions by gasification of Ivano-Frankivsk region” are parallel because the GDN is a comprehensive and uniform system, and the performance of individual steps (such as installation of protection plants from electrical and chemical corrosion without gas pipeline construction) is physically impossible. Ending of all phases is planned in 2012.

¹² <http://zavodarsenal.kiev.ua/>

¹³ <http://www.actaris.ru/gas/>



A.4.3. Brief explanation of how the anthropogenic emissions of greenhouse gases by sources are to be reduced by the proposed JI project, including why the emission reductions would not occur in the absence of the proposed project, taking into account national and/or sectoral policies and circumstances:

The project activities provide for the construction and expansion of gas distribution systems. In the baseline scenario heat-generating installations of end-consumers will continue to run on solid and liquid fuels. Such energy resources are characterized by high factor of greenhouse gas emissions in the stationary combustion. The project implementation will promote the transition from solid, liquid fuels to more efficient fuel - natural gas, which will lead to significant reductions in greenhouse gas emissions.

Increase in energy efficiency of thermal plants after gasification will promote decrease in energy consumption, leading to greenhouse gas emission reductions.

A.4.3.1. Estimated amount of emission reductions over the crediting period:

Table 1. Estimated amount of emission reductions for the period preceding the first commitment period (2004 - 2007)

	Years
Length of the crediting period	4
Year	Estimate of annual emission reductions in tonnes of CO ₂ equivalent
2004	1 172 403
2005	1 325 885
2006	1 239 929
2007	1 112 144
Total estimated emission reductions before the crediting period (tonnes of CO ₂ equivalent)	4 850 361
Annual average of estimated emission reductions before the crediting period (tonnes of CO ₂ equivalent)	1 212 590

Table 2. Estimated amount of emission reductions over the first commitment period (2008-2012)

	Years
Length of the crediting period	5
Year	Estimate of annual emission reductions in tonnes of CO ₂ equivalent
2008	1 010 779
2009	1 019 328
2010	1 129 323
2011	1 004 021
2012	1 004 021
Total estimated emission reductions over the crediting period (tonnes of CO ₂ equivalent)	5 167 472



Annual average of estimated emission reduction over the <u>crediting period</u> (tonnes of CO ₂ equivalent)	1 033 494
--	-----------

Table 3. Estimated amount of emission reductions for the period following the first commitment period (2013-2020)

	Years
Length of the <u>crediting period</u>	8
Year	Estimate of annual emission reductions in tonnes of CO ₂ equivalent
2013	1 004 021
2014	1 004 021
2015	1 004 021
2016	1 004 021
2017	1 004 021
2018	1 004 021
2019	1 004 021
2020	1 004 021
Total estimated emission reductions after the <u>crediting period</u> (tonnes of CO ₂ equivalent)	8 032 168
Annual average of estimated emission reduction after the <u>crediting period</u> (tonnes of CO ₂ equivalent)	1 004 021

Detailed information about emission reductions estimation can be found in Supporting Documents 1.1-1.3 (Excel files).

Description of formulae used for preliminary estimation of the quantity of emission reduction units is given in Section D and Supporting Documents 1.1-1.3.

Supporting Documents 1.1-1.3, 2, 3, 4 were submitted to the Accredited Independent Entity for determination.

A.5. Project approval by the Parties involved:

Letter of Endorsement No.2889/23/7 of 04/10/2012 was received for the JJ project "Reduction of greenhouse gases emissions by gasification of Ivano-Frankivsk region" by the State Environmental Investment Agency of Ukraine.

Upon determination of the project, the PDD and the Determination report will be submitted to the State Environmental Investment Agency of Ukraine in order to obtain a Letter of Approval.

**SECTION B. Baseline****B.1. Description and justification of the baseline chosen:**

The proposed project uses a specific approach for the determination of JJ projects based on approved methodology ACM0009 “Consolidated baseline and monitoring methodology for fuel switching from coal or petroleum fuel to natural gas” - Version 4.0.0¹⁴.

Dynamic baseline was chosen according to the requirements of the “Guidance on criteria for baseline setting and monitoring”, for the Joint Implementation Project Version 03¹⁵. According to the Guidelines for users of the Joint Implementation Project Design Document Form, Version 04¹⁶, a stepwise approach is used to describe and justify the baseline chosen:

Step 1. Identification and description of the selected approach for the baseline setting.

The baseline is determined by the selection of the most plausible scenario from a list and by the description of plausible future scenarios based on conservative assumptions.

The following steps were used to determine the most plausible baseline scenario:

1. Identification of plausible alternatives that could be the baseline scenario
2. Justification of exclusion from consideration of alternatives with a low plausibility from technical and / or economic point of view.

In the process of baseline setting and justification of additionality (Section B.2.) the following key factors were taken into account:

- Government's policies and applicable law in the energy sector;
- Economic situation in the energy sector in Ukraine and forecasted demand for fossil fuels;
- Technical aspects of management and operation of energy supply systems;
- Availability of capital, including investment barriers that are typical for PJSC “Ivano-Frankivskgas”;
- The local availability of technology / equipment;
- Price and availability of fuel.

Step 2. Application of the approach chosen

The choice of the plausible baseline scenario is based on assessment of alternative options for transportation of fossil fuels to end users that potentially could have taken place as of the beginning of the project implementation.

The following alternatives were analysed:

Alternative 1.1: Continuation of existing practice, without the JJ project.

Alternative 1.2: The project activities without the use of the Joint Implementation mechanism.

Below is a detailed analysis of each alternative.

¹⁴ <http://cdm.unfccc.int/methodologies/DB/49516CYT8X8LZ3F4YRXKSIHRXMOTR5>

¹⁵ http://ji.unfccc.int/Ref/Documents/Baseline_setting_and_monitoring.pdf

¹⁶ <http://ji.unfccc.int/Ref/Documents/Guidelines.pdf>

**Alternative 1.1**

Continuation of existing practice with minimum repairs, against the background of the general deterioration of gas supply systems.

State of the fuel and energy sector (energy supply systems) in Ukraine.

The state and development trends of energy supply systems in Ukraine were quite unsatisfactory in the baseline period. This was due to flawed principle of pricing for the provision of services, which failed to provide for development of subjects of the system, as well as the inflow of investment into the sector (lack of cost-effective modernization of equipment).

In the framework of the existing market model for the supply of fossil fuels, the effective competition among producers and suppliers of fuel could not be achieved; this market model couldn't also provide for the competitive fuel pricing, which would stimulate providers to improve efficiency and increase investment in the energy sector. Neither existing market mechanisms, nor targeted administrative measures did provide the necessary modernization of existing transportation systems. The situation is becoming particularly critical given the growth of the need for fossil fuel in the near future, the lack of which represents a threat to safe operation of local heating and hot water supply systems, electricity generation systems, and other consumers of fossil fuels. Inadequate tariff policy also leads to an increase in accounts payable of the fossil fuels suppliers that results in their bankruptcy or non-transparent privatization. State investment programs in most cases are targeted at the administrative and organizational implementations¹⁷. In addition, there are no conditions for contributing to the inflow of investment both from national and foreign investors.

This alternative is the most plausible baseline scenario because:

- It allows for transporting fossil fuels with existing facilities;
- It does not require investment in new equipment.

Accordingly, *Alternative 1.1* can be considered as the most plausible baseline.

Alternative 1.2

The project activities without the use of Joint Implementation mechanism.

The main obstacle that hinders the implementation of this scenario is an investment barrier, because it requires attracting significant additional funds. Such investment is characterized by a significant payback period and high investment risks.

This alternative cannot be considered as the most plausible baseline scenario, as the main obstacle to its implementation is the lack of investment in new manufacturing equipment and high investment risks.

Accordingly, *Alternative 1.2* cannot be viewed as the most plausible baseline.

Analysis of the alternatives described above shows that the most plausible alternative is *Alternative 1.1*.

Results of the performed investment analysis in Section B.2 show that *Alternative 1.2* can't be considered as the most plausible alternative from a financial point of view. Detailed information relating to analysis of investment barriers is provided in Section B.2.

The results of analysis performed in accordance with the "Tool for the demonstration and assessment of additionality"¹⁸ (Version 06.0.0) in Section B.2 show that the project scenario is additional.

¹⁷ http://www.ukrenergo.energy.gov.ua/ukrenergo/control/uk/publish/archive?&cat_id=33495&stind=1

¹⁸ <http://cdm.unfccc.int/methodologies/PAmethodologies/tools/am-tool-01-v6.0.0.pdf>

**Baseline scenario description**

The baseline scenario, which the power complex may follow, is to continue operating the existing systems of transportation and preparation of energy carrier as well as heat supply systems that will result in the use by the end consumers of less ecological fuel (fuel oil, coal), which will generate a significant amount of greenhouse gases (GHG) when burned. In addition, the continued operation of obsolete equipment (most of which was produced in the USSR) and, consequently, low efficiency of transportation system and energy consumption system will lead to excessive use of fossil fuel that would cause the harmful effects of atmosphere because of GHG emissions.

Determination of GHG emissions in the baseline scenario will be performed using a specific approach for joint implementation projects for each year when monitoring of the project activity will take place, in such a way so that to adjust volume of fossil fuel substituted with gas. This will allow for calculation of the volume of greenhouse gas emissions for each project year in the absence of the project activity.

Consumers, which are gasified within the framework of the JI project, are members of the sectors of housing (apartment buildings, private residences), industry, energy (district boiler rooms, municipal boiler houses, etc.) and administration (office and amenity buildings and structures). Industrial and administration consumers use fuel for heating, hot water supply and technical purposes. Energy sector uses fossil fuel for heat generation.

Housing consumers use fossil fuel for heating and hot water supply. Heat consumption for cooking is less than 1% of the total heat consumption of a consumer (heating, hot water supply). Besides, apartment buildings use electric stoves, which are not gasified in the course of the project activity due to fire safety standards. Thus, fossil fuel consumption for cooking is conservatively excluded from fossil fuel substituted with natural gas in the course of project activity.

Heat-generating units used by consumers for heating and hot water supply prior to the project have very low efficiency factors of fuel combustion (30-70%). In particular, housing sector often uses central heat supply networks (which provide heating and hot water supply), with an efficiency rate between 40 and 50%, individual double-circuit boilers (provide heat and hot water supply, efficiency rate is 60-70%), furnace heating and hot water supply (efficiency rate is 30-40%). Industrial and administrative sectors use both centralized networks and private boiler houses (efficiency rate is 50-70%).

Due to a large number of consumers, their wide variety in terms of sectors, and absence of data on types of heat-generating units, in accordance with conservative principles and based on approved methodology ACM0009 "Consolidated baseline and monitoring methodology for fuel switching from coal or petroleum fuel to natural gas" - Version 4.0.0¹⁹, the following efficiency factors were used for heat-generating units:

Heat supply technology	Default factor
New heat-generating unit that runs on fuel oil	0.9
New heat-generating unit that runs on coal	0.85
Old heat-generating unit that runs on fuel oil	0.85
Old heat-generating unit that runs on coal	0.8

¹⁹ <http://cdm.unfccc.int/methodologies/DB/49516CYT8X8LZ3F4YRXKSIHRXMOTR5>

These factors exceed substantially the efficiency factors of heat-generating units used by consumers prior to the project (described above), which leads to a decrease in calculated GHG emission reductions, which complies with conservative principles.

Leaks due to fossil fuel preparation and transportation to the consumer are excluded from calculations because they are beyond the project developer's control.

Information about the algorithm of baseline emissions calculation of baseline parameters is provided below and in Section D.1 and Annex 2.

Baseline GHG emissions:

$$BE_y = \sum_{i=1}^I BE_{i,y}, \text{ where:} \quad (\text{B.1})$$

BE_y - total greenhouse gas (GHG) emissions caused by the use of the old energy supply system by consumers, in period "y", in the baseline scenario (t CO₂e);

$BE_{i,y}$ - GHG emissions caused by the use of the old energy supply system by consumer "i", in period "y", in the baseline scenario (t CO₂e).

$$BE_{i,y} = \frac{FC_{FF,i,y} \cdot NCV_{FF,y} \cdot EF_{CO_2,FF,y}}{1000}, \text{ where:} \quad (\text{B.2})$$

$FC_{FF,i,y}$ - total amount of FF-type fossil fuel that would be combusted by consumer "i", in period "y", in the baseline scenario (t);

$NCV_{FF,y}$ - net calorific value of "FF"-type fossil fuel (GJ/t);

$EF_{CO_2,FF,y}$ - default carbon dioxide emission factor for stationary combustion of "FF"-type fossil fuel, in the baseline scenario (t CO₂/TJ);

1000 – GJ to TJ conversion coefficient (GJ/TJ).

$$FC_{FF,i,y} = FC_{NG,i,y} \cdot \frac{NCV_{NG,y} \cdot \eta_{PJ,i}}{NCV_{FF,y} \cdot \eta_{BL,i}}, \text{ where:} \quad (\text{B.3})$$

$FC_{NG,i,y}$ - volume of natural gas combusted by consumer "i", in period "y", in the project scenario (ths m³);

$NCV_{NG,y}$ - net calorific value of natural gas (GJ/ths m³);

$NCV_{FF,y}$ - net calorific value of "FF"-type fossil fuel (GJ/t);

$\eta_{PJ,i}$ - efficiency of stationary natural gas combustion at the site of consumer "i";

$\eta_{BL,i}$ - efficiency of stationary coal or fuel oil combustion at the site of consumer "i".

$$EF_{CO_2,FF,y} = EF_{C,FF,y} \cdot OXID_{FF,y} \cdot 44/12, \text{ where:} \quad (\text{B.4})$$

$EF_{C,FF,y}$ - carbon emission factor in the course of "FF"-type fossil fuel combustion (t C/TJ);

$OXID_{FF,y}$ - carbon oxidation factor in the course of "FF"-type fossil fuel combustion (relative units);

44/12 - stoichiometric ratio between the molecular weight of carbon dioxide and carbon (t CO₂/t C).



Detailed information about the algorithm of baseline emissions calculation of baseline parameters is provided in Section D.1 and Annex 2.

Key information for baseline setting is stated in the tables given below.

Data/Parameter	$FC_{NG,i,y}$
Data unit	ths m ³
Description	Total natural gas consumption in period “y” by consumer “i”
Time of <u>determination/monitoring</u>	Monthly
Source of data (to be) used	Gas meters
Value of data applied (for ex ante calculations/determinations)	Subject to periodical monitoring
Justification of the choice of data or description of measurement methods and procedures (to be) applied	Measurements will be performed by gas meters
QA/QC procedures (to be) applied	Equipment is calibrated and verified according to the quality management procedures, the law of Ukraine “On metrology and metrological activities” ²⁰ .
Any comment	A cubic meter, reduced to standard conditions (T = 20 degrees, C, P = 101.325 kPa (760 mm of mercury) and relative humidity is equal to zero) is taken as the unit of account of gas supplied to a consumer. Data about the amount of gas consumption by consumers are the basic data allowing for calculation of GHG emissions for each year in the <u>project</u> scenario; information will be archived in paper and electronic form

Data/Parameter	$NCV_{FF,y}$
Data unit	GJ/ t
Description	Net calorific value of “FF”-type fossil fuel. (“FF”-type fossil fuel means coal, fuel oil)
Time of <u>determination/monitoring</u>	Annually
Source of data (to be) used	The “National inventory report of anthropogenic greenhouse gas emissions by sources and removals by sinks in Ukraine for 1990-2010” ²¹

²⁰ <http://www.ucrf.gov.ua/uk/doc/laws/1099563058/>

²¹ http://unfccc.int/files/national_reports/annex_i_ghg_inventories/national_inventories_submissions/application/zip/ukr-2012-nir-13apr.zip



Value of data applied (for ex ante calculations/determinations)		2004	2005	2006	2007	2008
	Hard coal (for the population), GJ/ t	20.9	21.16	21.34	21.95	22.1
	Fuel oil (for heat generation), GJ/t	39.98	39.92	39.98	40.5	40.7
		2009	2010	2011	2012	
	Hard coal (for the population), GJ/ t	22.6	21.4	21.4	21.4	
	Fuel oil (for heat generation), GJ/t	40.4	40.5	40.5	40.5	
Justification of the choice of data or description of measurement methods and procedures (to be) applied	The parameter is used according to the approved CDM methodology ACM0009 “Consolidated baseline and monitoring methodology for fuel switching from coal or petroleum fuel to natural gas” - Version 4.0.0 ²² and “Guidance on criteria for <u>baseline setting and monitoring</u> ”, for the <u>Joint Implementation Project Version 03</u> ²³ . Net calorific value of natural gas that is based on officially approved national data will be used. Data on the type of fossil fuel used by the consumer before the gasification are provided by city administrations.					
QA/QC procedures (to be) applied	Officially approved national data that are actual at the moment of monitoring report preparation will be used.					
Any comment	Data allowing for calculation of GHG emissions in the baseline scenario; information will be archived in paper and electronic form.					

Data/Parameter	$NCV_{NG,y}$					
Data unit	GJ/ ths m ³					
Description	Net calorific value of natural gas					
Time of <u>determination/</u> <u>monitoring</u>	Annually					
Source of data (to be) used	The “National inventory report of anthropogenic greenhouse gas emissions by sources and removals by sinks in Ukraine for 1990-2010” ²⁴					
Value of data applied (for ex ante calculations/determinations)		2004	2005	2006	2007	2008
	Natural gas, GJ/ths m ³	33.82	33.82	33.85	33.85	33.8

²² <http://cdm.unfccc.int/methodologies/DB/49516CYT8X8LZ3F4YRXKSIHRXMOTR5>

²³ http://ji.unfccc.int/Ref/Documents/Baseline_setting_and_monitoring.pdf

²⁴ http://unfccc.int/files/national_reports/annex_i_ghg_inventories/national_inventories_submissions/application/zip/ukr-2012-nir-13apr.zip



	2009	2010	2011	2012	
Natural gas, GJ/th _s m ³	33.8	33.8	33.8	33.8	
Justification of the choice of data or description of measurement methods and procedures (to be) applied	The parameter is used according to the approved CDM methodology ACM0009 “Consolidated baseline and monitoring methodology for fuel switching from coal or petroleum fuel to natural gas” - Version 4.0.0 ²⁵ and “Guidance on criteria for <u>baseline setting and monitoring</u> ”, for the <u>Joint Implementation Project Version 03</u> ²⁶ . Net calorific value of natural gas that is based on officially approved national data will be used.				
QA/QC procedures (to be) applied	Officially approved national data that are actual at the moment of monitoring report preparation will be used.				
Any comment	According to principle of conservatism minimal calorific value of gas is used.				

Data/Parameter	$EF_{C,FF,y}$					
Data unit	t C/TJ					
Description	Carbon emission factor in the course of “FF”-type fossil fuel combustion (“FF”-type fossil fuel means coal, fuel oil)					
Time of determination/monitoring	Annually					
Source of data (to be) used	The “National inventory report of anthropogenic greenhouse gas emissions by sources and removals by sinks in Ukraine for 1990-2010” ²⁷					
Value of data applied (for ex ante calculations/determinations)		2004	2005	2006	2007	2008
	Hard coal,t C/TJ	26.78	26.8	26.8	26.8	25.3
	Fuel oil,t C/TJ	21.1	21.1	21.1	21.1	21.1
		2009	2010	2011	2012	
	Hard coal,t C/TJ	25.3	25.3	25.3	25.3	
	Fuel oil,t C/TJ	21.1	21.1	21.1	21.1	
Justification of the choice of data or description of measurement methods and procedures (to be) applied	According to “Guidance on criteria for <u>baseline setting and monitoring</u> ”, for the <u>Joint Implementation Project Version 03</u> ²⁸					

²⁵ <http://cdm.unfccc.int/methodologies/DB/49516CYT8X8LZ3F4YRXKSIHRXMOTR5>

²⁶ http://ji.unfccc.int/Ref/Documents/Baseline_setting_and_monitoring.pdf

²⁷ http://unfccc.int/files/national_reports/annex_i_ghg_inventories/national_inventories_submissions/application/zip/ukr-2012-nir-13apr.zip

²⁸ http://ji.unfccc.int/Ref/Documents/Baseline_setting_and_monitoring.pdf



QA/QC procedures (to be) applied	Officially approved national data that are actual at the moment of monitoring report preparation will be used.
Any comment	Data allowing for calculation of GHG emissions in the baseline scenario; information will be archived in paper and electronic form

Data/Parameter	$OXID_{FF,y}$					
Data unit	Relative units					
Description	Carbon oxidation factor in the course of fossil fuel of “FF” type combustion. (Fuel of “FF” type means coal, fuel oil)					
Time of determination/monitoring	Annually					
Source of data (to be) used	The “National inventory report of anthropogenic greenhouse gas emissions by sources and removals by sinks in Ukraine for 1990-2010” ²⁹					
Value of data applied (for ex ante calculations/determinations)		2004	2005	2006	2007	2008
	Hard coal, relative units	0.98	0.98	0.98	0.98	0.98
	Fuel oil, relative units	0.99	0.99	0.99	0.99	0.99
		2009	2010	2011	2012	
	Hard coal, relative units	0.98	0.98	0.98	0.98	
	Fuel oil, relative units	0.99	0.99	0.99	0.99	
Justification of the choice of data or description of measurement methods and procedures (to be) applied	Carbon oxidation factor in the course of fossil fuel combustion is used to determine the default carbon dioxide emission factor for stationary combustion of fossil fuels in Ukraine. The data source for this parameter is the “National inventory report of anthropogenic greenhouse gas emissions by sources and removals by sinks in Ukraine for 1990-2010” ³⁰ , based on approved national data.					
QA/QC procedures (to be) applied	Officially approved national data that are actual at the moment of the monitoring report preparation will be used.					
Any comment	Data allowing for calculation of GHG emissions in the baseline scenario; information will be archived in paper and electronic form					

Data/Parameter	$\eta_{PJ,i}$
Data unit	Relative units
Description	Efficiency of stationary natural gas combustion in at the site of

²⁹ http://unfccc.int/files/national_reports/annex_i_ghg_inventories/national_inventories_submissions/application/zip/ukr-2012-nir-13apr.zip

³⁰ http://unfccc.int/files/national_reports/annex_i_ghg_inventories/national_inventories_submissions/application/zip/ukr-2012-nir-13apr.zip



	consumer “i”
Time of <u>determination/monitoring</u>	Once at the beginning of the <u>project</u>
Source of data (to be) used	Detailed determination of the factor is provided in Supporting Document 3.
Value of data applied (for ex ante calculations/determinations)	0.92
Justification of the choice of data or description of measurement methods and procedures (to be) applied	This applies in case of transfer of individual and central heat supply systems to gas. This factor was determined by analyzing the actual performance characteristics of technological equipment located in different regions of Ukraine (Odesa, Donetsk, Kyiv, Mykolayiv regions).
QA/QC procedures (to be) applied	N/A
Any comment	Data allowing for calculation of GHG emissions in the baseline scenario; information will be archived in paper and electronic form

Data/Parameter	$\eta_{BL,y}$	
Data unit	Relative units	
Description	Efficiency of stationary coal or fuel oil combustion at the site of consumer “i”	
Time of <u>determination/monitoring</u>	Once at the beginning of the <u>project</u>	
Source of data (to be) used	Approved consolidated baseline and monitoring methodology ACM0009 “Consolidated baseline and monitoring methodology for fuel switching from coal or petroleum fuel to natural gas” - Version 4.0.0 ³¹ .	
Value of data applied (for ex ante calculations/determinations)	Heat supply technology	Default factor
	New fuel oil-run heat-generating unit	0.9
	New coal-run heat-generating unit	0.85
	Old fuel oil-run heat-generating unit	0.85
	Old coal-run heat-generating unit	0.8
Justification of the choice of data or description of measurement methods and procedures (to be) applied	Values are applied in accordance with Table 2 of the approved methodology “Consolidated baseline and monitoring methodology for fuel switching from coal or petroleum fuel to natural gas” - Version 4.0.0 ³² .	
QA/QC procedures (to be) applied	N/A	
Any comment	Data allowing for calculation of GHG emissions in the baseline scenario; information will be archived in paper and electronic form	

³¹ <http://cdm.unfccc.int/methodologies/DB/49516CYT8X8LZ3F4YRXKSIHRXMOTR5>

³² <http://cdm.unfccc.int/methodologies/DB/49516CYT8X8LZ3F4YRXKSIHRXMOTR5>

**B.2. Description of how the anthropogenic emissions of greenhouse gases by sources are reduced below those that would have occurred in the absence of the JI project:**

Anthropogenic emissions of greenhouse gases in the project scenario will be decreased due to complex modernization of the fossil fuel supply system by introduction of technologies proposed in the project activity and described above.

Additionality of the project

The additionality of the project activity is demonstrated and assessed by using the “Tool for the demonstration and assessment of additionality”³³ (Version 06.0.0). This manual was elaborated in original for CDM projects, but it may be also applied to JI projects.

Step 1. Identification of alternatives to the project activity and their consistency with current laws and regulations**Sub-step 1a. Define alternatives to the project activity**

There are two alternatives to this project (which have already been discussed in Section B.1).

Alternative 1.1: Continuation of existing situation, without JI project implementation.

Alternative 1.2: Project activity without application of Joint Implementation mechanism.

Outcome of Sub-step 1a. Two realistic alternative scenarios to the project activity are identified***Sub-step 1b. Consistency with mandatory laws and regulations***

Alternative 1.1: Continuation of current practice of exploitation of PJSC “Ivano-Frankivskgas” existing capacities is the most realistic and credible alternative to the Project implementation, since this variant is associated with minimal costs for PJSC “Ivano-Frankivskgas”.

No programs or regulations that oblige PJSC “Ivano-Frankivskgas” to gasify; neither there are legislative limitations of the baseline scenario. According to the Law of Ukraine “On principles of the natural gas market functioning”³⁴ Article 8, PJSC “Ivano-Frankivskgas” and the competent authorities of the government and local self-government shall:

- Ensure efficient use of natural, human and financial resources;
- Ensure the participation in the development and approval of plans of prospective development of gas pipelines on corresponding territory;
- Promote the development of gas distribution networks;
- Ensure the participation in formation and approval of the list of enterprises, which in the period of seasonal fall of temperature shall be converted to work with reserve fuel;
- Ensure compliance with the legislation of Ukraine in the field of environmental protection.

Article 13. Gas transmission enterprise:

- is obliged to ensure equal access to its networks for all suppliers and consumers of natural gas;
- during the transportation of natural gas is obliged to comply with the requirements for transportation of gas, set regulations and regulatory documents;
- has the right to transit natural gas through the territory of Ukraine, implementation of such activity can not restrict the scope of the enterprise as a participant of the natural gas market.

³³ <http://cdm.unfccc.int/methodologies/PAmethodologies/tools/am-tool-01-v6.0.0.pdf>

³⁴ <http://zakon1.rada.gov.ua/cgi-bin/laws/main.cgi?nreg=2467-17>



The current Ukrainian system of formation of the tariff for natural gas does not include any investment component for the development of gas distribution networks. According to the Law of Ukraine “On principles of natural gas market functioning”, PJSC “Ivano-Frankivskgas” is not obliged and it is unmotivated to build new gas distribution systems at its own expense.

Alternative 1.2: So far PJSC “Ivano-Frankivskgas” has not performed any significant measures for gasification. Moreover, PJSC “Ivano-Frankivskgas” does not have any incentives or funds for implementation of the measures provided by the Project in the absence of its support by the mechanisms established in article 6 of the Kyoto Protocol to the UN Framework Convention On Climate Change (step 1.2, step 2 and step 3 below). PJSC “Ivano-Frankivskgas” does not have any financial incentives to cover such costs on implementation of this Project or similar measures to the ones represented in this project, except for possible proceeds that are received under the mechanism established by article 6 of the Kyoto Protocol to the UN Framework Convention On Climate Change.

Construction, reconstruction and modernization without the use of JJ mechanism shall be consistent with mandatory laws and regulations. Detailed information on analysis of consistency with the law was made for *Alternative 1.1*, which is similar in terms of consistency with mandatory laws and regulations for *Alternative 1.2*.

Outcome of Sub-step 1b. Under such circumstances one may say that all scenarios are consistent with current laws and regulatory acts.

Therefore Step 1 is satisfied.

According to the document the “Tool for the demonstration and assessment of additionality”³⁵ (Version 06.0.0) further justification of additionality shall be performed by means of investment analysis.

Step 2 - Investment Analysis.

The main purpose of investment analysis is to determine whether the proposed project:

- (a) is not the most economically or financially attractive, or
- (b) is not economically or financial feasible without income from sale of emission reduction units (ERUs) related to the JJ project.

Sub-step 2a - Determination of appropriate analysis method.

There are three methods used for investment analysis: a simple cost analysis, a comparative investment analysis and a benchmark analysis. If the project activities and alternatives identified in Step 1 do not receive other financial or economic benefits other than income related to JJ, then the simple cost analysis (Variant I) is applied. Otherwise, the comparative investment analysis (Variant II) or the benchmark analysis (Variant III) are used.

Guidelines for additionality allow for performance of comparative investment analysis, which compares corresponding financial indices for the most realistic and reasonable investment alternatives (Variant II), or the benchmark analysis (Variant III). For this project it is appropriate to apply analysis using Variation III, according to the instructions of Guidelines for additionality.

Sub-step 2b–Banchmark analysis.

The proposed project “Reduction of greenhouse gases emissions by gasification of Ivano-Frankivsk region” will be implemented by the project participant, namely PJSC “Ivano-Frankivskgas”. The approach

³⁵ <http://cdm.unfccc.int/methodologies/PAmethodologies/tools/am-tool-01-v6.0.0.pdf>

recommended in paragraph 12 of the “Guidelines on the assessment of investment analysis ver.05”³⁶ provides for the use of a discount rate that is determined by considering the weighted average cost of capital (WACC). WACC is calculated as a weighted average cost of own and debt capital. The structure of capital is taken in the form of 50% of own and 50% of debt capital. In accordance with paragraph 18 of the “Guidelines on the assessment of investment analysis ver. 05”³⁷ cost of own capital is calculated as the sum of risk-free rate, the risk premium on investment in own capital and country risk³⁸, according to the “Default values for the expected return on equity”³⁹. The cost of own capital and listed indexes are given in table below. The cost of debt capital is estimated at the average cost of credit in foreign currency as of 2004 according to the NBU⁴⁰. Cash flow is adjusted by inflation index for the Eurozone⁴¹, because the calculations are made in euros.

Table 4. Initial data for investment analysis.

Expected price per ton of CO ₂ , Euro	1
Discount rate (IRR benchmark), based on WACC, %	14,5%
Inflation as of 2003	<u>2,10%</u>
Operational lifetime (min), year	20
The average rate on crediting in foreign currency as of 2003	<u>12,80%</u>
Cost of own capital	16,25%
Risk-free rate	<u>3%</u>
The risk premium on investment real economy	<u>6,50%</u>
The risk premium on investment in foreign economy	<u>6,75%</u>
Euro Exchange Rate	<u>6,02</u>

If the proposed project (not implemented as a JJ project) has a less favourable rate, i.e. lower internal rate of return (IRR), than the total limit level, the project may not be considered as financially attractive.

Sub-step 2c – Calculation and comparison of financial indicators.

Financial analysis refers to the time of making investment decisions. The following assumptions were used based on information provided by the company:

1. The settlement period is 17 years (minimum equipment operational life is 20 years);
 2. The residual value is calculated as the result of multiplication of unused resource for initial expenses.
- Analysis of cash flow takes into account the cash outflow connected with investments and operational costs⁴² and cash inflow associated with the receipt of revenues from providing of services by the enterprise. Financial performance of the project is provided below.

³⁶http://cdm.unfccc.int/Reference/Guidclarif/reg/reg_guid03.pdf

³⁷http://cdm.unfccc.int/Reference/Guidclarif/reg/reg_guid03.pdf

³⁸<http://pages.stern.nyu.edu/~adamodar/pc/archives/ctryprem06.xls>

³⁹http://cdm.unfccc.int/Panels/meth/meeting/11/049/mp49_an14.pdf

⁴⁰<http://www.bank.gov.ua/doccatalog/document?id=51803>

⁴¹<http://www.finfacts.ie/inflation.htm>

⁴² Supporting Document 2

Table 5. Financial indicators of the project

Revenues from gas supply without VAT (ths EUR)	Cash flow (ths EUR)	dr (discount rate)	NPV (ths EUR)	IRR (%)	Residual value (ths EUR)
90 789	-11 072	14,5%	-8651,02	-5,36%	22 154

The source of prices for the service of gas distribution and supply provided by PJSC “Ivano-Frankivskgas” is the information provided by the company and NERC of Ukraine Decree N 983 dated 04/09/2002, Kyiv “On approval of the method of calculating tariffs for the transportation and supply of natural gas for gas supply and gasification companies”⁴³.

When analyzing the cash flow the IRR that is below the established limit level of IRR (shown in table below). As a result NPV is negative. Therefore the project cannot be considered as financially attractive.

Sub-step 2d: Sensitivity analysis

The sensitivity analysis is conducted to confirm whether the conclusions on the financial / economic attractiveness are enough stable at different substantiated variants of the baseline conditions change. The following two key factors were considered in sensitivity analysis: investment and operational expenses as well as tariff for natural gas transportation. According to the guidelines for additionality (paragraph 17) the sensitivity analysis should be made for key indicators in the range of variation $\pm 10\%$.

Table 6. Price for gas supply the company

	-10%	0%	+10%
NPV (ths EUR)	-11788,11	-8651,02	-5513,93
IRR (%)	-8,90%	-5,36%	-1,10%

Table 7. Investment expenses

	-10%	0%	+10%
NPV (ths EUR)	-4648,83	-8651,02	-12653,22
IRR (%)	-0,55%	-5,36%	-8,59%

Sensitivity analysis was used to assess the sensitivity of the project to changes that may occur during the project implementation and operation. IRR varies because of changes of prices for natural gas transportation in the range of -10% and +10% demonstrated above. IRR varies because of changes of investment and operational costs in the range of -10% and +10% demonstrated above. Expenditures that are considered in the framework of the project are high, and increase of expenditures will result in a negative NPV. However in case of expected price of the investment and the income from the sale of ERUs the project is viable and will bring enough profit even in case of credit financing of the project and it should make a profit even if the above changes in price of investment take place.

Outcome of Step 2: sensitivity analysis consistently supports (for a realistic range of assumptions) the conclusion that the project is unlikely to be financially / economically attractive.

Step 3: Barrier Analysis

According to the Guidelines of additionality the barrier analysis was not conducted.

⁴³<http://zakon.nau.ua/doc/?code=v0983227-02>

**Step 4: Common practice analysis****Sub-step 4a. Analysis of other activities similar to the proposed project activity**

Analysis of other activities similar to the proposed project activity has shown that similar JIP "Reduction of greenhouse gases emissions by gasification of Mariupol city", "Reduction of greenhouse gases emissions by gasification of Kyiv city" was implemented within the territory of Ukraine; but according to the "Tool for the demonstration and assessment of additionality"⁴⁴ (Version 06.0.0) there is no need to conduct analysis of similar project activity.

Outcome of Sub-step 4a: There is no need to conduct analysis of similar project activity.

According to the "Tool for the demonstration and assessment of additionality"⁴⁵ (Version 06.0.0) all steps are satisfied.

Conclusion

Based on the above analysis we can conclude that the project is additional.

⁴⁴ <http://cdm.unfccc.int/methodologies/PAMethodologies/tools/am-tool-01-v6.0.0.pdf>

⁴⁵ <http://cdm.unfccc.int/methodologies/PAMethodologies/tools/am-tool-01-v6.0.0.pdf>

**B.3. Description of how the definition of the project boundary is applied to the project:**

Project boundary according to the specific approach is outlined by physical, geographic location of the unified gas supply system of PJSC “Ivano-Frankivskgas” (gas networks(total length – 2856,35 km) and gas supply facilities of settlements, the system of gas pipelines, GCP, GDP, pressure regulators, gas supply system of municipal and industrial enterprises, gas supply to buildings and structures , etc.). and includes all anthropogenic emissions by sources:

1. GHG emissions from fossil fuel combustion in heat-generating units due to the use of the old energy supply system by the consumers
2. GHG emissions from natural gas combustion in heat-generating units due to the use of the new energy supply system by the consumers;
3. GHG leaks from natural gas leaks in the course of gas transportation by gas transportation networks;
4. GHG leaks from gas fuel combustion by gas turbines in the process of natural gas transportation to end consumers place.

Leaks associated with fossil fuel supply to the consumer under the baseline scenario, are excluded from calculations because they are beyond the project developer’s control.

Table below demonstrates the overview of GHG emission sources in the baseline scenario boundary for the project.

Table 8. An overview of all sources of emissions in the baseline scenario

Source	Gas	Included / Excluded	Substantiation / explanation
<u>Baseline emissions</u>			
<u>GHG emissions</u> from fossil fuel combustion in heat-generating units due to the use of the old energy supply system by the consumers	CO ₂	Included	GHG emissions due to fossil fuel combustion by end consumers. The baseline scenario provides for the use of less environmentally friendly fuel (coal, fuel oil, diesel oil).

Table below demonstrates the overview of GHG emission sources in the project scenario boundary.

Table 9. An overview of all sources of emissions in the project scenario

Source	Gas	Included / Excluded	Substantiation / explanation
<u>Project emissions</u>			
<u>GHG emissions</u> from natural gas combustion in heat-generating units due to use of the new energy supply system by the consumers	CO ₂	Included	<u>GHG emissions</u> due to combustion of natural gas as more environmentally friendly fuel.



Table below demonstrates the overview of possible leak sources in the project and baseline scenarios.

Table 10. An overview of leak sources in the project and baseline scenarios

Source	Gas	Included / Excluded	Substantiation / explanation
Leaks			
<u>GHG leaks</u> from natural gas combustion by gas turbine units in the course of transportation of natural gas to end consumers	CO ₂	Included	<u>GHG leaks</u> in the process of combustion of natural gas by gas turbine units for transportation of natural gas to end consumers. Leaks relate to the project scenario.
<u>GHG leaks</u> in the course of gas transportation by gas transportation networks	CH ₄	Included	Methane leaks at technological equipment and at end consumer's place (valve stations, connections, thermal equipment etc.). Leaks relate to the project scenario.

**B.4. Further baseline information, including the date of baseline setting and the name(s) of the person(s)/entity(ies) setting the baseline:**

Baseline formation date: 24/09/2012

The baseline has been set by CEP Carbon Emissions Partners S.A. and PJSC “Ivano-Frankivskgas”.

PJSC “Ivano-Frankivskgas”:

76010, Ivano-Frankivsk, 20, Lenkavskoho Str.

Ihor Prokopiv

Chairman of the Board

Telephone: +38 (0342) 50 16 22

Fax: +38 (0342) 50 16 02

E-mail: boss@gaz.if.ua

PJSC “Ivano-Frankivskgas” is the project participant (stated in Annex 1).

CEP Carbon Emissions Partners S.A.:

Route de Thonon 52, Geneva, Case postale 170 CH-1222 Vérenaz, Switzerland.

Fabian Knodel,

Director.

Telephone: +41 (76) 346 11 57

Fax: +41 (76) 346 11 57

E-mail: 0709bp@gmail.com

CEP Carbon Emissions Partners S.A. is the project participant (stated in Annex 1).

**SECTION C. Duration of the project / crediting period****C.1. Starting date of the project:**

The starting date of the project is deemed to be 26/09/2003 when started activities on gas distribution network expansion within the framework of the Joint Implementation Project.

C.2. Expected operational lifetime of the project:

Number of project implementations in 2003 was not significant so the starting date of lifetime of the project is 01/01/2004

Expected operational lifetime of the project in years and months is 17 years or 204 months (from 01/01/2004 to 31/12/2020).

C.3. Length of the crediting period:

The project provides that the first assigned amount units are expected to be generated from 01/01/2004 to 31/12/2007. Generation of ERUs relates to the first commitment period for 5 years (01/01/2008 – 31/12/2012). Prolongation of the crediting period beyond 2012 is subject to approval by the host Party. Calculations of emission reductions are provided separately for the period before 2012 and after 2012.

If after the first commitment period under the Kyoto Protocol its validity is prolonged, the crediting period under the project will be prolonged by 8 years/96 months until December 31, 2020.

**SECTION D. Monitoring plan****D.1. Description of monitoring plan chosen:**

The proposed project uses a specific approach to JJ projects based on approved methodology ACM0009 “Consolidated baseline and monitoring methodology for fuel switching from coal or petroleum fuel to natural gas” - Version 4.0.0⁴⁶ and “Guidance on criteria for baseline setting and monitoring”, for the Joint Implementation Project Version 03⁴⁷. The monitoring plan is designed for accurate and clear measurement and calculation of greenhouse gas emissions and is implemented according to practices established at PJSC “Ivano-Frankivskgas” for measurement of supplied and consumed natural gas. Project monitoring does not require any changes in the existing system of data accounting and collection. All relevant data are calculated and recorded and stored within two years after transfer of the last emission reduction units generated by the project.

The monitoring plan includes measures (measurements, maintenance, registration and calibration), which should be implemented to satisfy the requirements of the chosen methodology of monitoring and guarantee the possibility of verification of calculation on GHG emission reductions. The main stages of the monitoring plan are described below.

Data and parameters not monitored throughout the whole crediting period, but determined only once, which are available at the stage of PDD development:

$\eta_{BL,i}$	Efficiency of stationary coal or fuel oil combustion at consumer’s “i” place, relative units
$\eta_{PJ,i}$	Efficiency of stationary natural gas combustion at consumer’s “i” place, relative units

Data and parameters that are not monitored during the crediting period but are identified only once and are not available at the PDD development stage: none

Data and parameters monitored during the whole crediting period:

$FC_{NG,i,y}$	Total volume of natural gas combusted in period “y” by consumer “i”, ths m ³
$L_{PJ,y}$	Length of gas distribution systems constructed in the framework of the project, ths km
$NCV_{NG,y}$	Net calorific value of natural gas, GJ/ ths m ³
$NCV_{FF,y}$	Net calorific value of fossil fuel of “FF” type, GJ/t (Fuel of “FF” type means coal, fuel oil)

⁴⁶ <http://cdm.unfccc.int/methodologies/DB/49516CYT8X8LZ3F4YRXKSIHRXMOTR5>

⁴⁷ http://ji.unfccc.int/Ref/Documents/Baseline_setting_and_monitoring.pdf



$EF_{C,NG,y}$	Carbon emission factor in the course of natural gas combustion, t C/TJ
$OXID_{NG,y}$	Carbon oxidation factor in the course of natural gas combustion, relative units
$EF_{C,FF,y}$	Carbon emission factor in the course of fossil fuel of “FF” type combustion, t C/TJ (Fuel of “FF” type means coal, fuel oil)
$OXID_{C,FF,y}$	Carbon oxidation factor in the course of fossil fuel of “FF” type combustion, relative units
$EF_{CH_4,los1,y}$	Default methane emission factor in the process of natural gas transportation and distribution, t CH ₄ e/ths km
$EF_{CH_4,los2,y}$	Default methane emission factor at technological gas equipment at end consumer’s place, t CH ₄ /PJ
$EF_{CO_2,GTU,y}$	Reduced GHG emission factor in the course of natural gas transportation to end consumers, t CO ₂ /m ³
GWP_{CH_4}	Global warming potential for methane, t CO ₂ e/t CH ₄

D.1.1. Option 1 – Monitoring of the emissions in the project scenario and the baseline scenario:

D.1.1.1. Data to be collected in order to monitor emissions from the project, and how these data will be archived:

Data/Parameter	$FC_{NG,i,y}$
Data unit	ths m ³
Description	Total quantity of natural gas combusted in period “y” by consumer “i”
Time of <u>determination/monitoring</u>	Monthly
Source of data (to be) used	Gas meters
Value of data applied (for ex ante calculations/determinations)	Subject to periodical monitoring
Justification of the choice of data or description of measurement methods and procedures (to be) applied	Measurements will be performed by gas meters

This template shall not be altered. It shall be completed without modifying/adding headings or logo, format or font.



Joint Implementation Supervisory Committee

QA/QC procedures (to be) applied	Equipment is calibrated and verified according to the quality management procedures, the law of Ukraine “On metrology and metrological activities” ⁴⁸ .
Any comment	A cubic meter, reduced to standard conditions (T = 20 degrees, C, P = 101.325 kPa (760 mm of mercury) and relative humidity is equal to zero) is taken as the unit of account of gas supplied to a consumer. Data about the amount of gas consumption by consumers are the basic data allowing for calculation of GHG emissions for each year in the project scenario; information will be archived in paper and electronic form

Data/Parameter	$NCV_{NG,y}$					
Data unit	GJ/th _s m ³					
Description	Net calorific value of natural gas					
Time of <u>determination/monitoring</u>	Annually					
Source of data (to be) used	The “National inventory report of anthropogenic greenhouse gas emissions by sources and removals by sinks in Ukraine for 1990-2010” ⁴⁹					
Value of data applied (for ex ante calculations/determinations)		2004	2005	2006	2007	2008
	Natural gas, GJ/th _s m ³	33.82	33.82	33.85	33.85	33.8
		2009	2010	2011	2012	
	Natural gas, GJ/th _s m ³	33.8	33.8	33.8	33.8	

⁴⁸ <http://www.ucrf.gov.ua/uk/doc/laws/1099563058/>

⁴⁹ http://unfccc.int/files/national_reports/annex_i_ghg_inventories/national_inventories_submissions/application/zip/ukr-2012-nir-13apr.zip



Joint Implementation Supervisory Committee

Justification of the choice of data or description of measurement methods and procedures (to be) applied	The parameter is used according to the approved CDM methodology ACM0009 “Consolidated baseline and monitoring methodology for fuel switching from coal or petroleum fuel to natural gas” - Version 4.0.0 ⁵⁰ and “Guidance on criteria for <u>baseline setting and monitoring</u> ”, for the <u>Joint Implementation Project Version 03</u> ⁵¹ . Net calorific value of natural gas that is based on officially approved national data will be used.
QA/QC procedures (to be) applied	Officially approved national data that are actual at the moment of monitoring report preparation will be used.
Any comment	According to principle of conservatism minimal calorific value of gas is used.

Data/Parameter	$EF_{C,NG,y}$						
Data unit	t C/TJ						
Description	Carbon emission factor in the course of natural gas combustion						
Time of <u>determination/monitoring</u>	Annually						
Source of data (to be) used	The “National inventory report of anthropogenic greenhouse gas emissions by sources and removals by sinks in Ukraine for 1990-2010” ⁵²						
Value of data applied (for ex ante calculations/determinations)		2004	2005	2006	2007	2008	
	Natural gas, t C/TJ	15.18	15.19	15.22	15.16	15.17	
		2009	2010	2011	2012		
	Natural gas, t C/TJ	15.2	15.17	15.17	15.17		

⁵⁰ <http://cdm.unfccc.int/methodologies/DB/49516CYT8X8LZ3F4YRXKSIHRXMOTR5>

⁵¹ http://ji.unfccc.int/Ref/Documents/Baseline_setting_and_monitoring.pdf

⁵² http://unfccc.int/files/national_reports/annex_i_ghg_inventories/national_inventories_submissions/application/zip/ukr-2012-nir-13apr.zip



Joint Implementation Supervisory Committee

Justification of the choice of data or description of measurement methods and procedures (to be) applied	According to “Guidance on criteria for <u>baseline setting and monitoring</u> ”, for the <u>Joint Implementation Project</u> Version 03 ⁵³ .
QA/QC procedures (to be) applied	Officially approved national data that are actual at the moment of monitoring report preparation will be used.
Any comment	Data allowing for calculation of GHG emissions in the project scenario; information will be archived in paper and electronic form

Data/Parameter	$OXID_{NG,y}$					
Data unit	Relative units					
Description	Carbon oxidation factor in the course of natural gas combustion.					
Time of <u>determination/monitoring</u>	Annually					
Source of data (to be) used	The “National inventory report of anthropogenic greenhouse gas emissions by sources and removals by sinks in Ukraine for 1990-2010” ⁵⁴					
Value of data applied (for ex ante calculations/determinations)		2004	2005	2006	2007	2008
	Natural gas, relative units	0.995	0.995	0.995	0.995	0.995
		2009	2010	2011	2012	
	Natural gas, relative units	0.995	0.995	0.995	0.995	
Justification of the choice of data or description of measurement methods and	Carbon oxidation factor in the course of natural gas combustion is used to determine the default carbon dioxide emission factor for stationary combustion of fossil fuels in Ukraine. The data source for					

⁵³ http://ji.unfccc.int/Ref/Documents/Baseline_setting_and_monitoring.pdf

⁵⁴ http://unfccc.int/files/national_reports/annex_i_ghg_inventories/national_inventories_submissions/application/zip/ukr-2012-nir-13apr.zip



procedures (to be) applied	this parameter is the “National inventory report of anthropogenic greenhouse gas emissions by sources and removals by sinks in Ukraine for 1990-2010” ⁵⁵ , based on approved national data.
QA/QC procedures (to be) applied	Officially approved national data that are actual at the moment of the monitoring report preparation will be used.
Any comment	Data allowing for calculation of GHG emissions in the project scenario; information will be archived in paper and electronic form

D.1.1.2. Description of formulae used to estimate project emissions (for each gas, source etc.; emissions in units of CO₂ equivalent):

GHG emissions in the project scenario:

$$PE_y = \sum_{i=1}^I PE_{i,y}, \text{ where:} \quad (D.1)$$

PE_y - total quantity of greenhouse gas (GHG) emissions from natural gas combustion caused by the use of the new energy supply system by consumers, in period “y”, in the project scenario (t CO_{2e});

$PE_{i,y}$ - GHG emissions from natural gas combustion caused by the use of the new energy supply system by consumer “i”, in period “y”, in the project scenario (t CO_{2e});

y - index that corresponds to monitoring period;

i - index that corresponds to consumer.

$$PE_{i,y} = \frac{FC_{NG,i,y} \cdot NCV_{NG,y} \cdot EF_{CO_2,NG,y}}{1000}, \text{ where:} \quad (D.2)$$

$FC_{NG,i,y}$ - volume of natural gas combusted by consumer “i”, in period “y”, in the project scenario (ths m³);

$NCV_{NG,y}$ - net calorific value of natural gas (GJ/ths m³);

$EF_{CO_2,NG,y}$ - default carbon dioxide emission factor for stationary combustion of natural gas, in the project scenario (t CO₂ /TJ);

⁵⁵ http://unfccc.int/files/national_reports/annex_i_ghg_inventories/national_inventories_submissions/application/zip/ukr-2012-nir-13apr.zip



1000 – GJ to TJ conversion factor (GJ/TJ).

NG - index that corresponds to natural gas;

y - index that corresponds to monitoring period;

i - index that corresponds to consumer.

$$EF_{CO_2,NG,y} = EF_{C,NG,y} \cdot OXID_{NG,y} \cdot 44 / 12, \text{ where:} \quad (D.3)$$

$EF_{C,NG,y}$ - carbon emission factor in the course of natural gas combustion (t C/TJ);

$OXID_{NG,y}$ - carbon oxidation factor in the course of natural gas combustion (relative units);

44 / 12 - stoichiometric ratio between the molecular weight of carbon dioxide and carbon (t CO₂ / t C);

NG - index that corresponds to natural gas;

y - index that corresponds to monitoring period.

D.1.1.3. Relevant data necessary for determining the baseline of anthropogenic emissions of greenhouse gases by sources within the project boundary, and how such data will be collected and archived:

Data/Parameter	$FC_{NG,i,y}$
Data unit	ths m ³
Description	Total quantity of natural gas combusted in period “y” by consumer “i”
Time of determination/monitoring	Monthly
Source of data (to be) used	Gas meters
Value of data applied (for ex ante calculations/determinations)	Subject to periodical monitoring
Justification of the choice of data or description of measurement methods and procedures (to be) applied	Measurements will be performed by gas meters

This template shall not be altered. It shall be completed without modifying/adding headings or logo, format or font.



Joint Implementation Supervisory Committee

QA/QC procedures (to be) applied	Equipment is calibrated and verified according to the quality management procedures, the law of Ukraine “On metrology and metrological activities” ⁵⁶ .
Any comment	A cubic meter, reduced to standard conditions (T = 20 degrees, C, P = 101.325 kPa (760 mm. of mercury) and relative humidity is equal to zero) is taken as the unit of account of gas supplied to a consumer. Data about the amount of gas consumption by consumers are the basic data allowing for calculation of GHG emissions for each year in the project scenario; information will be archived in paper and electronic form

Data/Parameter	$NCV_{FF,y}$					
Data unit	GJ/ t					
Description	Net calorific value of fossil fuel of “FF” type. (Fuel of “FF” type means coal, fuel oil)					
Time of determination/monitoring	Annually					
Source of data (to be) used	The “National inventory report of anthropogenic greenhouse gas emissions by sources and removals by sinks in Ukraine for 1990-2010” ⁵⁷					
Value of data applied (for ex ante calculations/determinations)		2004	2005	2006	2007	2008
	Hard coal (for the population), GJ/ t	20.9	21.16	21.34	21.95	22.1
	Fuel oil (for heat generation), GJ/t	39.98	39.92	39.98	40.5	40.7

⁵⁶ <http://www.ucrf.gov.ua/uk/doc/laws/1099563058/>

⁵⁷ http://unfccc.int/files/national_reports/annex_i_ghg_inventories/national_inventories_submissions/application/zip/ukr-2012-nir-13apr.zip



	2009	2010	2011	2012	
Hard coal (for the population), GJ/ t	22.6	21.4	21.4	21.4	
Fuel oil (for heat generation), GJ/t	40.4	40.5	40.5	40.5	
Justification of the choice of data or description of measurement methods and procedures (to be) applied	The parameter is used according to the approved CDM methodology ACM0009 “Consolidated baseline and monitoring methodology for fuel switching from coal or petroleum fuel to natural gas” - Version 4.0.0 ⁵⁸ and “Guidance on criteria for <u>baseline setting and monitoring</u> ”, for the <u>Joint Implementation Project Version 03</u> ⁵⁹ . Net calorific value of natural gas that is based on officially approved national data will be used. Data on the type of fossil fuel used by the consumer before the gasification are provided by city administrations.				
QA/QC procedures (to be) applied	Officially approved national data that are actual at the moment of monitoring report preparation will be used.				
Any comment	Data allowing for calculation of GHG emissions in the baseline scenario; information will be archived in paper and electronic form.				

⁵⁸ <http://cdm.unfccc.int/methodologies/DB/49516CYT8X8LZ3F4YRXXSIHRXMOTR5>

⁵⁹ http://ji.unfccc.int/Ref/Documents/Baseline_setting_and_monitoring.pdf



Data/Parameter	$NCV_{NG,y}$					
Data unit	GJ/th _s m ³					
Description	Net calorific value of natural gas					
Time of determination/monitoring	Annually					
Source of data (to be) used	The “National inventory report of anthropogenic greenhouse gas emissions by sources and removals by sinks in Ukraine for 1990-2010” ⁶⁰					
Value of data applied (for ex ante calculations/determinations)		2004	2005	2006	2007	2008
	Natural gas, GJ/th _s m ³	33.82	33.82	33.85	33.85	33.8
		2009	2010	2011	2012	
	Natural gas, GJ/th _s m ³	33.8	33.8	33.8	33.8	
Justification of the choice of data or description of measurement methods and procedures (to be) applied	The parameter is used according to the approved CDM methodology ACM0009 “Consolidated baseline and monitoring methodology for fuel switching from coal or petroleum fuel to natural gas” - Version 4.0.0 ⁶¹ and “Guidance on criteria for <u>baseline setting and monitoring</u> ”, for the <u>Joint Implementation Project Version 03</u> ⁶² . Net calorific value of natural gas that is based on officially approved national data will be used.					
QA/QC procedures (to be) applied	Officially approved national data that are actual at the moment of monitoring report preparation will be used.					
Any comment	According to principle of conservatism minimal calorific value of gas is used.					

⁶⁰ http://unfccc.int/files/national_reports/annex_i_ghg_inventories/national_inventories_submissions/application/zip/ukr-2012-nir-13apr.zip

⁶¹ <http://cdm.unfccc.int/methodologies/DB/49516CYT8X8LZ3F4YRXKSIHRXMOTR5>

⁶² http://ji.unfccc.int/Ref/Documents/Baseline_setting_and_monitoring.pdf



Data/Parameter	$EF_{C,FF,y}$					
Data unit	t C/TJ					
Description	Carbon emission factor in the course of fossil fuel of “FF” type combustion. (Fuel of “FF” type means coal, fuel oil)					
Time of determination/monitoring	Annually					
Source of data (to be) used	The “National inventory report of anthropogenic greenhouse gas emissions by sources and removals by sinks in Ukraine for 1990-2010” ⁶³					
Value of data applied (for ex ante calculations/determinations)		2004	2005	2006	2007	2008
	Hard coal, t C/TJ	26.78	26.8	26.8	26.8	25.3
	Fuel oil, t C/TJ	21.1	21.1	21.1	21.1	21.1
		2009	2010	2011	2012	
	Hard coal, t C/TJ	25.3	25.3	25.3	25.3	
	Fuel oil, t C/TJ	21.1	21.1	21.1	21.1	
Justification of the choice of data or description of measurement methods and procedures (to be) applied	According to “Guidance on criteria for <u>baseline setting and monitoring</u> ”, for the <u>Joint Implementation Project</u> Version 03 ⁶⁴ .					
QA/QC procedures (to be) applied	Officially approved national data that are actual at the moment of monitoring report preparation will be used.					
Any comment	Data allowing for calculation of GHG emissions in the baseline scenario; information will be archived in paper and electronic form					

⁶³ http://unfccc.int/files/national_reports/annex_i_ghg_inventories/national_inventories_submissions/application/zip/ukr-2012-nir-13apr.zip

⁶⁴ http://ji.unfccc.int/Ref/Documents/Baseline_setting_and_monitoring.pdf



Data/Parameter	$OXID_{FF,y}$						
Data unit	Relative units						
Description	Carbon oxidation factor in the course of fossil fuel of “FF” type combustion. (Fuel of “FF” type means coal, fuel oil).						
Time of <u>determination/monitoring</u>	Annually						
Source of data (to be) used	The “National inventory report of anthropogenic greenhouse gas emissions by sources and removals by sinks in Ukraine for 1990-2010” ⁶⁵						
Value of data applied (for ex ante calculations/determinations)		2004	2005	2006	2007	2008	
	Hard coal, relative units	0.98	0.98	0.98	0.98	0.98	
	Fuel oil, relative units	0.99	0.99	0.99	0.99	0.99	
		2009	2010	2011	2012		
	Hard coal, relative units	0.98	0.98	0.98	0.98		
	Fuel oil, relative units	0.99	0.99	0.99	0.99		
Justification of the choice of data or description of measurement methods and procedures (to be) applied	Carbon oxidation factor in the course of fossil fuel combustion is used to determine the default carbon dioxide emission factor for stationary combustion of fossil fuels in Ukraine. The data source for this parameter is the “National inventory report of anthropogenic greenhouse gas emissions by sources and removals by sinks in Ukraine for 1990-2010” ⁶⁶ , based on approved national data.						
QA/QC procedures (to be) applied	Officially approved national data that are actual at the moment of the monitoring report preparation will be used.						

⁶⁵ http://unfccc.int/files/national_reports/annex_i_ghg_inventories/national_inventories_submissions/application/zip/ukr-2012-nir-13apr.zip

⁶⁶ http://unfccc.int/files/national_reports/annex_i_ghg_inventories/national_inventories_submissions/application/zip/ukr-2012-nir-13apr.zip



Any comment	Data allowing for calculation of GHG emissions in the baseline scenario; information will be archived in paper and electronic form
-------------	--

Data/Parameter	$\eta_{PJ,i}$
Data unit	Relative units
Description	Efficiency of stationary natural gas combustion at the site of consumer “i”
Time of <u>determination/monitoring</u>	Once at the beginning of the project
Source of data (to be) used	Detailed determination of the factor is provided in Supporting Document 3.
Value of data applied (for ex ante calculations/determinations)	0.92
Justification of the choice of data or description of measurement methods and procedures (to be) applied	This applies in case of transfer of individual and central heat supply systems to gas. This factor was determined by analyzing the actual performance characteristics of technological equipment located in different regions of Ukraine (Odesa, Donetsk, Kyiv, Mykolayiv regions).
QA/QC procedures (to be) applied	N/A
Any comment	Data allowing for calculation of GHG emissions in the baseline scenario; information will be archived in paper and electronic form

Data/Parameter	$\eta_{BL,y}$
Data unit	Relative units
Description	Efficiency of stationary coal or fuel oil combustion at the site of consumer “i”
Time of	Once at the beginning of the project



determination/monitoring		
Source of data (to be) used	Approved consolidated baseline and monitoring methodology ACM0009 “Consolidated baseline and monitoring methodology for fuel switching from coal or petroleum fuel to natural gas” - Version 4.0.0 ⁶⁷ .	
Value of data applied (for ex ante calculations/determinations)	Heat supply technology	Default factor
	New fuel oil-run heat-generating unit	0.9
	New coal-run heat-generating unit	0.85
	Old fuel oil-run heat-generating unit	0.85
	Old coal-run heat-generating unit	0.8
Justification of the choice of data or description of measurement methods and procedures (to be) applied	Values are applied in accordance with Table 2 of the approved methodology “Consolidated baseline and monitoring methodology for fuel switching from coal or petroleum fuel to natural gas” - Version 4.0.0 ⁶⁸ .	
QA/QC procedures (to be) applied	N/A	
Any comment	Data allowing for calculation of GHG emissions in the baseline scenario; information will be archived in paper and electronic form	

⁶⁷ <http://cdm.unfccc.int/methodologies/DB/49516CYT8X8LZ3F4YRXKSIHRXMOTR5>

⁶⁸ <http://cdm.unfccc.int/methodologies/DB/49516CYT8X8LZ3F4YRXKSIHRXMOTR5>

**D.1.1.4. Description of formulae used to estimate baseline emissions (for each gas, source etc.; emissions in units of CO₂ equivalent):**

Greenhouse gas baseline emissions:

$$BE_y = \sum_{i=1}^I BE_{i,y}, \text{ where:} \quad (D.4)$$

BE_y - total quantity of greenhouse gas (GHG) emissions from fossil fuel combustion caused by the use of the old energy supply system by consumers, in period “y”, in the baseline scenario (t CO₂e);

$BE_{i,y}$ - GHG emissions from fossil fuel combustion caused by the use of the old energy supply system by consumer “i”, in period “y”, in the baseline scenario (t CO₂e);

y - index that corresponds to monitoring period;

i - index that corresponds to consumer.

I - index that corresponds to total number of consumers.

$$BE_{i,y} = \frac{FC_{FF,i,y} \cdot NCV_{FF,y} \cdot EF_{CO_2,FF,y}}{1000}, \text{ where:} \quad (D.5)$$

$FC_{FF,i,y}$ - total quantity of fossil fuel of “FF” type that would be combusted by consumer “i”, in period “y”, in the baseline scenario (t);

$NCV_{FF,y}$ net calorific value of fossil fuel of “FF” type (GJ/t);

$EF_{CO_2,FF,y}$ - default carbon dioxide emission factor for stationary combustion of fossil fuel of “FF” type, in the baseline scenario (t CO₂/TJ);

1000 – GJ to TG conversion factor (GJ/TJ).

y - index that corresponds to monitoring period;

BL - index that corresponds to the baseline scenario;

FF - index that corresponds to type of fossil fuel;

i - index that corresponds to consumer.

$$FC_{FF,i,y} = FC_{NG,i,y} \cdot \frac{NCV_{NG,y} \cdot \eta_{PJ,i}}{NCV_{FF,y} \cdot \eta_{BL,i}}, \text{ where:} \quad (D.6)$$

This template shall not be altered. It shall be completed without modifying/adding headings or logo, format or font.



$FC_{NG,i,y}$ - volume of natural gas combusted by consumer “ i ”, in period “ y ”, in the project scenario (ths m³);

$NCV_{NG,y}$ - net calorific value of natural gas (GJ/ths m³);

$NCV_{FF,y}$ - net calorific value of fossil fuel of “ FF ” type (GJ/t);

$\eta_{PJ,i}$ - Efficiency of stationary natural gas combustion at the site of consumer “ i ”;

$\eta_{BL,i}$ - Efficiency of stationary coal or fuel oil combustion at the site of consumer “ i ”;

y^- - index that corresponds to monitoring period;

y_0^- - index that corresponds to the baseline scenario;

NG - index that corresponds to natural gas;

FF - index that corresponds to type of fossil fuel;

i - index that corresponds to consumer.

$EF_{CO_2,FF,y} = EF_{C,FF,y} \cdot OXID_{FF,y} \cdot 44 / 12$, where: (D.7)

$EF_{C,FF,y}$ - carbon emission factor in the course of fossil fuel of “ FF ” type combustion (t C/TJ);

$OXID_{FF,y}$ - carbon oxidation factor in the course of fossil fuel of “ FF ” type combustion (relative units);

$44 / 12$ - stoichiometric ratio between the molecular weight of carbon dioxide and carbon (t CO₂ / t C);

y^- - index that corresponds to monitoring period;

FF - index that corresponds to type of fossil fuel.

**D. 1.2. Option 2 – Direct monitoring of emission reductions from the project (values should be consistent with those in section E.):****D.1.2.1. Data to be collected in order to monitor emission reductions from the project, and how these data will be archived:**

ID number (Please use numbers to ease cross-referencing to D.2.)	Data variable	Source of data	Data unit	Measured (m), calculated (c), estimated (e)	Recording frequency	Proportion of data to be monitored	How will the data be archived? (electronic/paper)	Comment

N/A

D.1.2.2. Description of formulae used to calculate emission reductions from the project (for each gas, source etc.; emissions/emission reductions in units of CO₂ equivalent):

N/A

D.1.3. Treatment of leakage in the monitoring plan:**D.1.3.1. If applicable, please describe the data and information that will be collected in order to monitor leakage effects of the project:**

Data/Parameter	$FC_{NG,i,y}$
Data unit	ths m ³
Description	Total quantity of natural gas combusted in period “y” by consumer “i”
Time of <u>determination/monitoring</u>	Monthly
Source of data (to be) used	Gas meters
Value of data applied (for ex ante calculations/determinations)	Subject to periodical monitoring

This template shall not be altered. It shall be completed without modifying/adding headings or logo, format or font.



Joint Implementation Supervisory Committee

Justification of the choice of data or description of measurement methods and procedures (to be) applied	Measurements will be performed by gas meters
QA/QC procedures (to be) applied	Equipment is calibrated and verified according to the quality management procedures, the law of Ukraine “On metrology and metrological activities” ⁶⁹ .
Any comment	A cubic meter, reduced to standard conditions (T = 20 degrees, C, P = 101.325 kPa (760 mm. of mercury) and relative humidity is equal to zero) is taken as the unit of account of gas supplied to a consumer. Data about the amount of gas consumption by consumers are the basic data allowing for calculation of GHG leaks for each year in the project scenario; information will be archived in paper and electronic form

Data/Parameter	$NCV_{NG,y}$						
Data unit	GJ/ ths m ³						
Description	Net calorific value of natural gas						
Time of <u>determination/monitoring</u>	Annually						
Source of data (to be) used	The “National inventory report of anthropogenic greenhouse gas emissions by sources and removals by sinks in Ukraine for 1990-2010” ⁷⁰						
Value of data applied (for ex ante calculations/determinations)		2004	2005	2006	2007	2008	
	Natural gas, GJ/ths m ³	33.82	33.82	33.85	33.85	33.8	

⁶⁹ <http://www.ucrf.gov.ua/uk/doc/laws/1099563058/>

⁷⁰ http://unfccc.int/files/national_reports/annex_i_ghg_inventories/national_inventories_submissions/application/zip/ukr-2012-nir-13apr.zip



	2009	2010	2011	2012	
Natural gas, GJ/th _s m ³	33.8	33.8	33.8	33.8	
Justification of the choice of data or description of measurement methods and procedures (to be) applied	The parameter is used according to the approved CDM methodology ACM0009 “Consolidated baseline and monitoring methodology for fuel switching from coal or petroleum fuel to natural gas” - Version 4.0.0 ⁷¹ and “Guidance on criteria for <u>baseline setting and monitoring</u> ”, for the <u>Joint Implementation Project</u> Version 03 ⁷² . Net calorific value of natural gas that is based on officially approved national data will be used.				
QA/QC procedures (to be) applied	Officially approved national data that are actual at the moment of monitoring report preparation will be used.				
Any comment	According to principle of conservatism minimal calorific value of gas is used.				

Data/Parameter	$EF_{CO_2,GTU,y}$
Data unit	t CO _{2e} /m ³
Description	Reduced GHG emission factor in the course of natural gas transportation to end consumers
Time of <u>determination/monitoring</u>	Once at the beginning of the project
Source of data (to be) used	Official data of the Ministry of Energy and Coal Industry of Ukraine and the “National inventory report of anthropogenic greenhouse gas emissions by sources and removals by sinks in Ukraine for 1990-2010” ⁷³ .

⁷¹ <http://cdm.unfccc.int/methodologies/DB/49516CYT8X8LZ3F4YRXKSIHRXMOTR5>

⁷² http://ji.unfccc.int/Ref/Documents/Baseline_setting_and_monitoring.pdf

⁷³ http://unfccc.int/files/national_reports/annex_i_ghg_inventories/national_inventories_submissions/application/zip/ukr-2012-nir-13apr.zip



	Detailed calculation and the reference to the source of data are provided in the Supporting Document 1.3 (Excel file) and Annex 3.				
Value of data applied (for ex ante calculations/determinations)	Reduced GHG emission factor in the course of transportation of 1000 m ³ of gas, $EF_{CO_2,GTU,y}$, t CO ₂ e/ths m ³				
	2004	2005	2006	2007	2008
	0.072873	0.096111	0.071339	0.067368	0.074541
	2009	2010	2011	2012	
	0.057990	0.049032	0.046397	0.046397	
Justification of the choice of data or description of measurement methods and procedures (to be) applied	See Annex 3				
QA/QC procedures (to be) Applied	Calculations are based on the officially approved national data of the Ministry of Energy and Coal Industry of Ukraine and the “National inventory report of anthropogenic greenhouse gas emissions by sources and removals by sinks in Ukraine for 1990-2010” ⁷⁴ .				
Any comment	N/A				

Data/Parameter	$L_{PJ,y}$
Data unit	ths km
Description	Length of gas distribution systems constructed in the framework of the project
Time of <u>determination/monitoring</u>	Monthly
Source of data (to be) used	Commissioning of gas distribution networks certificate
Value of data applied	Subject to periodic monitoring

⁷⁴ http://unfccc.int/files/national_reports/annex_i_ghg_inventories/national_inventories_submissions/application/zip/ukr-2012-nir-13apr.zip



Joint Implementation Supervisory Committee

(for ex ante calculations/determinations)	
Justification of the choice of data or description of measurement methods and procedures (to be) applied	Monitoring of the length of constructed gas distribution systems will be carried out by people responsible for this activity on the basis of commissioning certificates for each monitoring period. The length of gas distribution systems built in monitoring period “y” will be calculated by summing up the lengths of gas pipelines under each commissioning certificate for the period.
QA/QC procedures (to be) applied	See Section D.2. below
Any comment	Data allowing for calculation of GHG leaks in the project scenario; information will be archived in paper and electronic form

Data/Parameter	$EF_{CH_4,los1,y}$
Data unit	t CH ₄ /ths km
Description	Default methane emission factor in the course of natural gas transportation and distribution
Time of <u>determination/monitoring</u>	Annually
Source of data (to be) used	The “National inventory report of anthropogenic greenhouse gas emissions by sources and removals by sinks in Ukraine for 1990-2010” ⁷⁵ . Table 1.V.2
Value of data applied (for ex ante calculations/determinations)	Subject to periodic monitoring
Justification of the choice of data or description of measurement methods and procedures (to be) applied	Default methane emission factor in the course of natural gas transportation and distribution is used for determining of GHG emissions from methane leaks at technological equipment. The data source for this parameter is the “National inventory report of

⁷⁵ http://unfccc.int/files/national_reports/annex_i_ghg_inventories/national_inventories_submissions/application/zip/ukr-2012-nir-13apr.zip



Joint Implementation Supervisory Committee

	anthropogenic greenhouse gas emissions by sources and removals by sinks in Ukraine for 1990-2010 ⁷⁶ , based on approved national data.
QA/QC procedures (to be) applied	Officially approved national data that are actual at the moment of the monitoring report preparation will be used.
Any comment	Data allowing for calculation of GHG leaks in the project scenario; information will be archived in paper and electronic form

Data/Parameter	$EF_{CH_4,los2,y}$
Data unit	t CH ₄ /PJ
Description	Default methane emission factor at technological gas equipment at end consumers place
Time of determination/monitoring	Annually
Source of data (to be) used	The “National inventory report of anthropogenic greenhouse gas emissions by sources and removals by sinks in Ukraine for 1990-2010” ⁷⁷ . Table 1.V.2
Value of data applied (for ex ante calculations/determinations)	Subject to periodic monitoring
Justification of the choice of data or description of measurement methods and procedures (to be) applied	Default methane emission factor at technological gas equipment at end consumers place is used for determining of GHG emissions from methane leaks at technological equipment at end consumer place. The data source for this parameter is the “National inventory report of anthropogenic greenhouse gas emissions by sources and removals by sinks in Ukraine for 1990-2010” ⁷⁸ , based on approved national data.

⁷⁶ http://unfccc.int/files/national_reports/annex_i_ghg_inventories/national_inventories_submissions/application/zip/ukr-2012-nir-13apr.zip

⁷⁷ http://unfccc.int/files/national_reports/annex_i_ghg_inventories/national_inventories_submissions/application/zip/ukr-2012-nir-13apr.zip

⁷⁸ http://unfccc.int/files/national_reports/annex_i_ghg_inventories/national_inventories_submissions/application/zip/ukr-2012-nir-13apr.zip



QA/QC procedures (to be) applied	Officially approved national data that are actual at the moment of the monitoring report preparation will be used.
Any comment	Data allowing for calculation of GHG leaks in the project scenario; information will be archived in paper and electronic form

Data/Parameter	GWP_{CH_4}
Data unit	t CO ₂ e / t CH ₄
Description	Global warming potential for methane
Time of determination/monitoring	Once at the beginning of the project
Source of data (to be) used	According to data approved by the IPCC
Value of data applied (for ex ante calculations/determinations)	21
Justification of the choice of data or description of measurement methods and procedures (to be) applied	Global warming potential for methane is determined according to the decision 2/CP.3 and provided in IPCC Guidelines
QA/QC procedures (to be) applied	The value is used for the first commitment period and may subsequently be revised in accordance with Article 5 of the Kyoto Protocol.
Any comment	N/A

D.1.3.2. Description of formulae used to estimate leakage (for each gas, source etc.; emissions in units of CO₂ equivalent):

Greenhouse gas (GHG) leaks:

$$LE_y = LE_{CO_2,los,y} + LE_{CO_2,GTU,y}, \text{ where:} \quad (D.8)$$

$LE_{CO_2,los,y}$ - methane leaks at technological equipment and at end consumer's place in period "y", in the project scenario (t CO₂e);

$LE_{CO_2,GTU,y}$ - GHG leaks due to combustion of gas fuel by gas turbine units in the course of transportation of natural gas to end consumers (t CO₂e);

This template shall not be altered. It shall be completed without modifying/adding headings or logo, format or font.



$[y]$ - index that corresponds to the monitoring period;

$[los]$ - index that corresponds to methane leaks at technological equipment and at a site of end consumers;

$[GTU]$ - index that corresponds to leaks from gas fuel combustion by gas turbine installations in the course of natural gas transportation to end consumers.

$$LE_{CO_2,los,y} = LE_{CO_2,los1,y} + LE_{CO_2,los2,y}, \text{ where:} \quad (D.9)$$

$LE_{CO_2,los1,y}$ - GHG leaks from methane leaks at technological equipment in period “y”, in the project scenario (t CO_{2e});

$LE_{CO_2,los2,y}$ - GHG leaks from methane leaks at equipment of end consumers in period “y”, in the project scenario (t CO_{2e});

$[y]$ - index that corresponds to the monitoring period;

$[los]$ - index that corresponds to methane leaks at technological equipment and at a site of end consumers;

$[los1]$ - index that corresponds to methane leaks at technological equipment;

$[los2]$ - index that corresponds to methane leaks at equipment of end consumers.

$$LE_{CO_2,los1,y} = \sum L_{PJ,y} \cdot EF_{CH_4,los1,y} \cdot GWP_{CH_4}, \text{ where:} \quad (D.10)$$

$L_{p,los1,y}$ - Length of gas distribution systems constructed in the framework of the project (ths km);

$EF_{CH_4,p,los1,y}$ - Default methane emission factor in the course of natural gas transportation and distribution (t CH₄ /ths km);

GWP_{CH_4} - Global warming potential for methane; it is determined according to the IPCC recommendations, (tCO₂/tCH₄);

$[y]$ - index that corresponds to the monitoring period;

$[los1]$ - index that corresponds to methane leaks at technological equipment;

$[PJ]$ - index that corresponds to project scenario;

CH_4 - index that corresponds to methane.

$$LE_{CO_2,los2,y} = \frac{\sum_i FC_{NG,i,y} \cdot NCV_{NG,y} \cdot EF_{CH_4,los2,y} \cdot GWP_{CH_4}}{10^6}, \text{ where:} \quad (D.11)$$



$\sum_1^i FC_{NG,i,y}$ - Total quantity of natural gas combusted in period “y” by consumers (ths m³);

$NCV_{NG,y}$ - Net calorific value of natural gas (GJ/ths m³);

$EF_{CH_4,los2,y}$ - Default methane emission factor at technological gas equipment at end consumers place (t CH₄ /PJ).

GWP_{CH_4} - Global warming potential for methane, t CO₂/t CH₄; it is determined according to the IPCC recommendations, (tCO₂/tCH₄);

10⁶ - GJ to PJ conversion factor (GJ/PJ);

\bar{y} - index that corresponds to the monitoring period;

NG - index that corresponds to natural gas;

CH_4 - index that corresponds to methane;

i - index that corresponds to consumer;

[$los2$] - index that corresponds to methane leaks at equipment of end consumers;

[I] - index that corresponds to total number of consumers.

$$LE_{CO_2,GTU,y} = \sum_1^I FC_{NG,i,y} \cdot EF_{CO_2,GTU,y}, \text{ where:} \quad (D.12)$$

$\sum_1^i FC_{NG,i,y}$ - Total quantity of natural gas combusted in period “y” by consumer “i” (ths m³);

$EF_{CO_2,GTU,y}$ - Reduced GHG emission factor in the course of natural gas transportation to end consumers (t CO₂ /m³). Determination of the factor is provided in section of Annex 3 and in Supporting Document 1.3. (Excel file);

[GTU] - index that corresponds to leaks from gas fuel combustion by gas turbine installations in the course of natural gas transportation to end consumers;

\bar{y} - index that corresponds to the monitoring period;

NG - index that corresponds to natural gas;

i - index that corresponds to consumer.

**D.1.4. Description of formulae used to estimate emission reductions for the project (for each gas, source etc.; emissions/emission reductions in units of CO₂ equivalent):****Quantity of Emission Reduction Units (ER), t CO₂e:**

$$ERU_y = BE_y - PE_y - LE_y, \text{ where:} \quad (D.13)$$

BE_y - total quantity of greenhouse gas (GHG) emissions from natural gas combustion caused by the use of the old energy supply system by consumers, in period “y”, in the baseline scenario (t CO_{2e});

PE_y - total quantity of greenhouse gas (GHG) emissions from natural gas combustion caused by the use of the new energy supply system by consumers, in period “y”, in the project scenario (t CO_{2e});

LE_y - GHG leaks caused by the use of the new energy supply system by consumers, in period “y”, in the project scenario (t CO_{2e});

y - index that corresponds to monitoring period.

D.1.5. Where applicable, in accordance with procedures as required by the host Party, information on the collection and archiving of information on the environmental impacts of the project:

The main legislative acts of Ukraine concerning the monitoring of the environmental impact of business entities are:

- Law of Ukraine № 1264-XII “On environmental protection”⁷⁹ dated 25/06/1991;
- Law of Ukraine № 2707-XII “On atmospheric air protection”⁸⁰ dated 16/10/1992.
- Current rules on emission limitation: “Norms of maximum permissible emissions of pollutants from permanent sources” – approved by the Ministry of Environmental Protection of Ukraine dated 27/06/2006, №309 and registered in the Ministry of Justice of Ukraine dated 01/09/2006, №912/12786.

In the framework of procedures performed at the request of the Law of Ukraine “On State Statistics”, the company periodically reports on environmental indicators, in particular environmental department of PJSC “Ivano-Frankivskgas” develops quarterly report in the form № 2-TP (air) that is submitted to the State Statistics.

⁷⁹<http://zakon.rada.gov.ua/cgi-bin/laws/main.cgi?nreg=1264-12>

⁸⁰<http://zakon.rada.gov.ua/cgi-bin/laws/main.cgi?nreg=2707-12>



D.2. Quality control (QC) and quality assurance (QA) procedures undertaken for data monitored:		
Data (Indicate table and ID number)	Uncertainty level of data (high/medium/low)	Explain QA/QC procedures planned for these data, or why such procedures are not necessary.
$FC_{NG,i,y}$	Low	Calibration of accounting and metering devices is carried out according to manufacturer's instructions, approved methodologies of verification / calibration of metering equipment and also in accordance with the national standards of Ukraine;
$NCV_{NG,y}$	Low	Net calorific value of natural gas is determined according to the "National inventory report of anthropogenic greenhouse gas emissions by sources and removals by sinks in Ukraine for 1990-2010" ⁸¹ , issued by the State Environmental Investment Agency of Ukraine. This document is subject to periodic review and adding of actual data thereto.
$NCV_{FF,y}$	Low	Net calorific value of fossil fuel is determined according to the "National inventory report of anthropogenic greenhouse gas emissions by sources and removals by sinks in Ukraine for 1990-2010" ⁸² , issued by the State Environmental Investment Agency of Ukraine. This document is subject to periodic review and adding of actual data thereto.
$L_{PJ,y}$	Low	The length of gas distribution systems, implemented in the framework of the project, assembly and technical service of PJSC "Ivano-Frankivskgas" is responsible for collection of information (Commissioning certificate).
$EF_{C,NG,y}$	Low	Carbon emission factor for natural gas combustion is determined according to the "National inventory report of anthropogenic greenhouse gas emissions by sources and removals by sinks in Ukraine for 1990-2010" ⁸³ , issued by the State Environmental Investment Agency of Ukraine. This document is subject to periodic review and adding of actual data thereto.
$OXID_{NG,y}$	Low	Carbon oxidation factor for natural gas combustion is determined according to the "National inventory report of anthropogenic greenhouse gas emissions by sources and removals by sinks in Ukraine for 1990-2010" ⁸⁴ , issued by the State Environmental Investment Agency of Ukraine. This document is subject to periodic review and adding of actual data thereto.

⁸¹ http://unfccc.int/files/national_reports/annex_i_ghg_inventories/national_inventories_submissions/application/zip/ukr-2012-nir-13apr.zip

⁸² http://unfccc.int/files/national_reports/annex_i_ghg_inventories/national_inventories_submissions/application/zip/ukr-2012-nir-13apr.zip

⁸³ http://unfccc.int/files/national_reports/annex_i_ghg_inventories/national_inventories_submissions/application/zip/ukr-2012-nir-13apr.zip

⁸⁴ http://unfccc.int/files/national_reports/annex_i_ghg_inventories/national_inventories_submissions/application/zip/ukr-2012-nir-13apr.zip



$EF_{C,FF,y}$	Low	Carbon emission factor for fossil fuel of “FF” type combustion is determined according to the “National inventory report of anthropogenic greenhouse gas emissions by sources and removals by sinks in Ukraine for 1990-2010” ⁸⁵ , issued by the State Environmental Investment Agency of Ukraine. This document is subject to periodic review and adding of actual data thereto.
$OXID_{FF,y}$	Low	Carbon oxidation factor for fossil fuel of “FF” type combustion is determined according to the “National inventory report of anthropogenic greenhouse gas emissions by sources and removals by sinks in Ukraine for 1990-2010” ⁸⁶ , issued by the State Environmental Investment Agency of Ukraine. This document is subject to periodic review and adding of actual data thereto.
$EF_{CH_4,los1,y}$	Low	Default methane emission factor in the course of natural gas transportation and distribution is determined according to the “National inventory report of anthropogenic greenhouse gas emissions by sources and removals by sinks in Ukraine for 1990-2010” ⁸⁷ , issued by the State Environmental Investment Agency of Ukraine. This document is subject to periodic review and adding of actual data thereto.
$EF_{CH_4,los2,y}$	Low	Default methane emission factor at technological gas equipment at the site of end consumers is determined according to the “National inventory report of anthropogenic greenhouse gas emissions by sources and removals by sinks in Ukraine for 1990-2010” ⁸⁸ , issued by the State Environmental Investment Agency of Ukraine. This document is subject to periodic review and adding of actual data thereto.

According to the Law of Ukraine “On metrology and metrological activity”⁸⁹, metering devices operating at PJSC “Ivano-Frankivskgas” is subject to periodic verification and calibration. The frequency of verification/calibration is set under the manufacturers’ manuals, approved methodologies on verification/calibration of metering devices, as well as the national standards of Ukraine.

⁸⁵ http://unfccc.int/files/national_reports/annex_i_ghg_inventories/national_inventories_submissions/application/zip/ukr-2012-nir-13apr.zip

⁸⁶ http://unfccc.int/files/national_reports/annex_i_ghg_inventories/national_inventories_submissions/application/zip/ukr-2012-nir-13apr.zip

⁸⁷ http://unfccc.int/files/national_reports/annex_i_ghg_inventories/national_inventories_submissions/application/zip/ukr-2012-nir-13apr.zip

⁸⁸ http://unfccc.int/files/national_reports/annex_i_ghg_inventories/national_inventories_submissions/application/zip/ukr-2012-nir-13apr.zip

⁸⁹ <http://www.ucrf.gov.ua/uk/doc/laws/1099563058/>



D.3. Please describe the operational and management structure that the project operator will apply in implementing the monitoring plan:

Operational and management structure to be applied by PJSC “Ivano-Frankivskgas” for implementation of monitoring is given below.

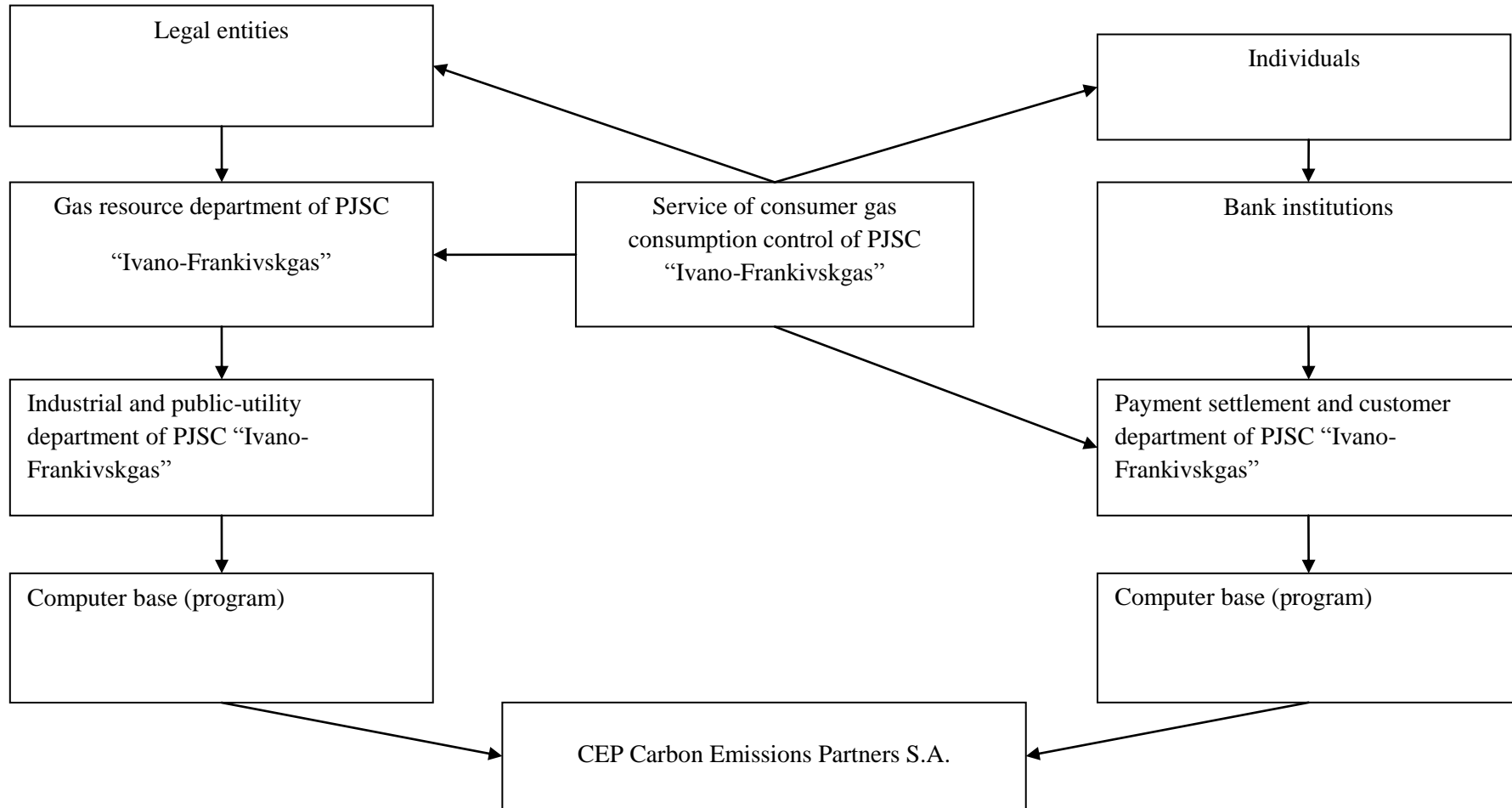

Figure 9. Structure of collection and processing of gas supply data.

This template shall not be altered. It shall be completed without modifying/adding headings or logo, format or font.



Monitoring of natural gas consumption by legal entities.

1. Legal entities supply information on gas consumption to the Gas resource department of PJSC “Ivano-Frankivskgas” every month.
2. Gas resource department conducts monthly inspections of meters, executes a certificate signed by the enterprise and transfers it to the Industrial and public-utility department of PJSC “Ivano-Frankivskgas”.
3. Industrial and public-utility department of PJSC “Ivano-Frankivskgas” processes information into basic form by program.
4. Indices of gas supply volume processed by program are delivered to the project developer.

Monitoring of natural gas consumption by individuals.

1. Service of consumer gas consumption control conducts monthly inspections of meters, executes a certificate signed by an individual and transfers it to the Consumers service.
2. Bank institutions deliver the information on gas consumption in the form of paid bills to the Payment settlement and customer department of PJSC “Ivano-Frankivskgas”.
3. Consumers service processes received information and bases it into program.
4. Indices of gas supply volume processed by program are delivered to the project developer.

The length of gas distribution systems, implemented in the framework of the project is determined by the assembly and technical service based on GDN commissioning certificates.

Project monitoring does not require any changes in PJSC “Ivano-Frankivskgas” existing data accounting and collection system.

The data subject to monitoring and required for determination and further verification will be archived and stored at PJSC “Ivano-Frankivskgas” for two years after the transfer of emission reduction units generated by the project.



D.4. Name of person(s)/entity(ies) establishing the monitoring plan:

The monitoring plan is determined by the project developer, CEP Carbon Emissions Partners S.A. and PJSC “Ivano-Frankivskgas”.

PJSC “Ivano-Frankivskgas”:

76010, Ivano-Frankivsk, 20, Lenkavskoho Str.

Ihor Prokopiv

Chairman of the Board

Telephone: +38 (0342) 50 16 22

Fax: +38 (0342) 50 16 02

E-mail: boss@gaz.if.ua

PJSC “Ivano-Frankivskgas” is the project participant (stated in Annex 1).

CEP Carbon Emissions Partners S.A.:

Route de Thonon 52, Geneva, Case postale 170 CH-1222 Vérenaz, Switzerland.

Fabian Knodel,

Director.

Telephone: +41 (76) 346 11 57

Fax: +41 (76) 346 11 57

E-mail: 0709bp@gmail.com

CEP Carbon Emissions Partners S.A. is the project participant (stated in Annex 1).

**SECTION E. Estimation of greenhouse gas emission reductions****E.1. Estimated project emissions:**

Estimation of project emissions was made according to the formulas given in Section D.1.1.2. Results of calculations are given in tables below. The calculations are presented in Supporting Document 1.1-1.3 (Excel files) attached to PDD.

Estimated project emissions for the period of 2004-2011 are calculated using actual data of PJSC “Ivano-Frankivskgas” on gas transportation volumes; for the period of 2012-2020 estimated data according to the company strategic development plan were used.

Table 11. Estimated project emissions for the period preceding the first commitment period January 1, 2004 – December 31, 2007

Year	<u>Project</u> emissions (tonnes of CO ₂ equivalent)
2004	1 438 315
2005	1 655 860
2006	1 586 213
2007	1 436 909
Total <u>project</u> emissions over the period 2004 to 2007 (tonnes of CO ₂ equivalent)	6 117 297

Table 12. Estimated project emissions during the first commitment January 1, 2008 – December 31, 2012

Year	<u>Project</u> emissions (tonnes of CO ₂ equivalent)
2008	1 521 868
2009	1 509 955
2010	1 636 625
2011	1 475 427
2012	1 475 427
Total <u>project</u> emissions over the period from 2008 to 2012 (tonnes of CO ₂ equivalent)	7 619 302

Table 13. Estimated project emissions for the period following the first commitment period January 1, 2013 - December 31, 2020

Year	<u>Project</u> emissions (tonnes of CO ₂ equivalent)
2013	1 475 427
2014	1 475 427
2015	1 475 427
2016	1 475 427
2017	1 475 427
2018	1 475 427
2019	1 475 427
2020	1 475 427
Total <u>project</u> emissions over the period from 2013 to 2020 (tonnes of CO ₂ equivalent)	11 803 416

**E.2. Estimated leakage:**

Estimation of project leakages was performed by the formulae specified in Section D.1.3.2. To estimate leakages for the period 2004-2011 existing data of PJSC “Ivano-Frankivskgas” relating to actual monitoring parameters values during the relevant period were used, predicted data according to the company development plan were used for the period 2012-2020.

The calculation results are provided in the tables below. The calculations are provided in Supporting Document 1.1-1.3 (Excel files) attached to the PDD.

Table 14. Estimated project leakage for the period preceding the first commitment period (January 1, 2004– December 31, 2007)

Year	Estimated project leakage (tonnes of CO ₂ equivalent)
2004	226 906
2005	288 145
2006	298 770
2007	288 865
Total estimated project leakage over the period 2004 to 2007 (tonnes of CO ₂ equivalent)	1 102 686

Table 15. Estimated project leakages during the first commitment period (January 1, 2008 – December 31, 2012)

Year	Estimated project leakage (tonnes of CO ₂ equivalent)
2008	304 747
2009	291 065
2010	294 557
2011	280 134
2012	280 134
Total estimated project leakage over the period from 2008 to 2012 (tonnes of CO ₂ equivalent)	1 450 637

Table 16. Estimated project leakages for the period following the first commitment period (January 1, 2013 – December 31, 2020)

Year	Estimated project leakage (tonnes of CO ₂ equivalent)
2013	280 134
2014	280 134
2015	280 134
2016	280 134
2017	280 134
2018	280 134
2019	280 134
2020	280 134
Total estimated project leakage over the period from 2013 to 2020 (tonnes of CO ₂ equivalent)	2 241 072

Detailed calculations are provided in Supporting Documents 1.1-1.3.

**E.3. The sum of E.1 and E.2:**

The calculation results are provided in the tables below. The calculations are provided in Supporting Documents 1.1-1.3 (Excel files) attached to the PDD.

Table 17. Table containing sum of emissions from leakages due to project activities during the first commitment period (January 1, 2004– December 31, 2007)

Year	Estimated <u>project</u> emissions (tonnes of CO ₂ equivalent)	Estimated <u>leakage</u> (tonnes of CO ₂ equivalent)	Estimated emissions and <u>leakage</u> (tonnes of CO ₂ equivalent)
2004	1 438 315	226 906	1 665 221
2005	1 655 860	288 145	1 944 005
2006	1 586 213	298 770	1 884 983
2007	1 436 909	288 865	1 725 774
Total emissions (tonnes of CO₂ equivalent)	6 117 297	1 102 686	7 219 983

Table 18. Table containing sum of emissions from leakages due to project activities during the first commitment period (January 1, 2008 – December 31, 2012)

Year	Estimated <u>project</u> emissions (tonnes of CO ₂ equivalent)	Estimated <u>leakage</u> (tonnes of CO ₂ equivalent)	Estimated emissions and <u>leakage</u> (tonnes of CO ₂ equivalent)
2008	1 521 868	304 747	1 826 615
2009	1 509 955	291 065	1 801 020
2010	1 636 625	294 557	1 931 182
2011	1 475 427	280 134	1 755 561
2012	1 475 427	280 134	1 755 561
Total emissions (tonnes of CO₂ equivalent)	7 619 302	1 450 637	9 069 939

Table 19. Table containing sum of emissions from leakages due to project activities after the first commitment period (January 1, 2013 – December 31, 2020)

Year	Estimated <u>project</u> emissions (tonnes of CO ₂ equivalent)	Estimated <u>leakage</u> (tonnes of CO ₂ equivalent)	Estimated emissions and <u>leakage</u> (tonnes of CO ₂ equivalent)
2013	1 475 427	280 134	1 755 561
2014	1 475 427	280 134	1 755 561
2015	1 475 427	280 134	1 755 561
2016	1 475 427	280 134	1 755 561
2017	1 475 427	280 134	1 755 561
2018	1 475 427	280 134	1 755 561
2019	1 475 427	280 134	1 755 561
2020	1 475 427	280 134	1 755 561
Total emissions (tonnes of CO₂ equivalent)	11 803 416	2 241 072	14 044 488

**E.4. Estimated baseline emissions:**

Estimation of baseline emissions was made according to the formulae given in Section D.1.1.4.

Results of calculations are given in tables below. The calculations are presented in Supporting Document 1.1-1. 3 (Excel files) attached to the PDD.

Estimated baseline GHG emissions for the period of 2004-2011 are calculated by taking ex-post data of gas consumed by PJSC “Ivano-Frankivskgas”, for the period of 2012-2020 predicted data according to the company development plan were used.

Table 20. Estimated baseline emissions for the period preceding the first commitment period January 1, 2004 – December 31, 2007

Year	Estimated <u>baseline emissions</u> (tonnes of CO ₂ equivalent)
2004	2 837 624
2005	3 269 890
2006	3 124 912
2007	2 837 918
Total <u>baseline</u> emissions over the period 2004 to 2007 (tonnes of CO ₂ equivalent)	12 070 344

Table 21. Estimated baseline emissions during the first commitment period January 1, 2008 roky – December 31, 2012

Year	Estimated <u>baseline emissions</u> (tonnes of CO ₂ equivalent)
2008	2 837 394
2009	2 820 348
2010	3 060 505
2011	2 759 582
2012	2 759 582
Total baseline emissions over the period from 2008 to 2012 (tonnes of CO ₂ equivalent)	14 237 411

Table 22. Estimated baseline emissions for the period following the first commitment period January 1, 2013 - December 31, 2020

Year	Estimated <u>baseline emissions</u> (tonnes of CO ₂ equivalent)
2013	2 759 582
2014	2 759 582
2015	2 759 582
2016	2 759 582
2017	2 759 582
2018	2 759 582
2019	2 759 582
2020	2 759 582
Total <u>baseline</u> emissions over the period from 2013 to 2020 (tonnes of CO ₂ equivalent)	22 076 656

**E.5. Difference between E.4. and E.3. representing the emission reductions of the project:**

Emission reductions were calculated according to the formula (D.13) provided in Section D.1.1.4. Results of calculations are given in tables below. The calculations are presented in Supporting Document 1.1-1. 3 (Excel files) attached to the PDD.

Table 23. Estimated emission reduction for the period preceding the first commitment period from January 1, 2004– December 31, 2007

Year	Estimated emission reduction (tonnes of CO ₂ equivalent)
2004	1 172 403
2005	1 325 885
2006	1 239 929
2007	1 112 144
Total estimated emission reduction over the period 2004 to 2007 (tonnes of CO ₂ equivalent)	4 850 361

Table 24. Estimated emission reduction during the first commitment period from January 1, 2008 – December 31, 2012

Year	Estimated emission reduction (tonnes of CO ₂ equivalent)
2008	1 010 779
2009	1 019 328
2010	1 129 323
2011	1 004 021
2012	1 004 021
Total estimated emission reduction over the period from 2008 to 2012 (tonnes of CO ₂ equivalent)	5 167 472

Table 25. Estimated emission reduction for the period following the first commitment period January 1, 2013 - December 31, 2020

Year	Estimated emission reduction (tonnes of CO ₂ equivalent)
2013	1 004 021
2014	1 004 021
2015	1 004 021
2016	1 004 021
2017	1 004 021
2018	1 004 021
2019	1 004 021
2020	1 004 021
Total estimated emission reduction over the period from 2013 to 2020 (tonnes of CO ₂ equivalent)	8 032 168

**E.6. Table providing values obtained when applying formulae above:***Table 26. Table containing results of estimation reduction for the period preceding the first commitment period from January 1, 2004, to December 31, 2007.*

Year	Estimated <u>project</u> emissions (tonnes of CO ₂ equivalent)	Estimated <u>leakage</u> (tonnes of CO ₂ equivalent)	Estimated <u>baseline</u> <u>emissions</u> (tonnes of CO ₂ equivalent)	Estimated emission reduction (tonnes of CO ₂ equivalent)
2004	1 438 315	226 906	2 837 624	1 172 403
2005	1 655 860	288 145	3 269 890	1 325 885
2006	1 586 213	298 770	3 124 912	1 239 929
2007	1 436 909	288 865	2 837 918	1 112 144
Total (tonnes of CO₂ equivalent)	6 117 297	1 102 686	12 070 344	4 850 361

Table 27. Table containing results of estimation of emission reduction during the first commitment period from January 1, 2008, to December 31, 2012

Year	Estimated <u>project</u> emissions (tonnes of CO ₂ equivalent)	Estimated <u>leakage</u> (tonnes of CO ₂ equivalent)	Estimated <u>baseline</u> <u>emissions</u> (tonnes of CO ₂ equivalent)	Estimated emission reduction (tonnes of CO ₂ equivalent)
2008	1 521 868	304 747	2 837 394	1 010 779
2009	1 509 955	291 065	2 820 348	1 019 328
2010	1 636 625	294 557	3 060 505	1 129 323
2011	1 475 427	280 134	2 759 582	1 004 021
2012	1 475 427	280 134	2 759 582	1 004 021
Total (tonnes of CO₂ equivalent)	7 619 302	1 450 637	14 237 411	5 167 472

Table 28. Table containing results of estimation reduction for the period following the first commitment period January 1, 2013, to December 31, 2020

Year	Estimated <u>project</u> emissions (tonnes of CO ₂ equivalent)	Estimated <u>leakage</u> (tonnes of CO ₂ equivalent)	Estimated <u>baseline</u> <u>emissions</u> (tonnes of CO ₂ equivalent)	Estimated emission reduction (tonnes of CO ₂ equivalent)
2013	1 475 427	280 134	2 759 582	1 004 021
2014	1 475 427	280 134	2 759 582	1 004 021
2015	1 475 427	280 134	2 759 582	1 004 021
2016	1 475 427	280 134	2 759 582	1 004 021
2017	1 475 427	280 134	2 759 582	1 004 021
2018	1 475 427	280 134	2 759 582	1 004 021
2019	1 475 427	280 134	2 759 582	1 004 021
2020	1 475 427	280 134	2 759 582	1 004 021
Total (tonnes of CO₂ equivalent)	11 803 416	2 241 072	22 076 656	8 032 168

**SECTION F. Environmental impacts****F.1. Documentation on the analysis of the environmental impacts of the project, including transboundary impacts, in accordance with procedures as determined by the host Party:**

According to the Ukrainian legislation, projects of new construction of gas distribution networks must include Environmental Impact Assessment (EIA), the basic requirements of which are listed in the State building norms of Ukraine A.2.2-1-2003 “The composition and content of environmental impact assessment (EIA) in the design and construction of plants, buildings and structures”⁹⁰.

PJSC “Ivano-Frankivskgas” has the necessary Environmental Impact Assessment for all projects on gas distribution network construction in accordance with Ukrainian law. EIA of the projects is developed by subcontracting project-assembling organizations and is provided in the sections of reconstruction project document of PJSC “Ivano-Frankivskgas”.

Overall, the impact of the project “Reduction of greenhouse gases emissions by gasification of Ivano-Frankivsk region” on the environment during the construction work can be assessed as permissible, because the impact is temporary. Project facilities are not included in the list of activities and facilities of environmental hazard.

Analysis of the facilities impact of the environment showed that taking into account all the considered factors, we can conclude that in the normal technical operational mode they will neither cause any negative processes in the environment of the city, nor lead to any negative social and economic consequences and the risk of accidents and their possible impact is minimized.

Facilities included in the project boundaries meet all standards and requirements of the Laws of Ukraine “On air protection”⁹¹ and “On Environmental Protection”⁹², and the SSR -96 “Planning and development of human settlements”, are ecologically safe and have no negative impact on the environment.

Transboundary impacts of the project activities according to their definition in the text of ratified by Ukraine “Convention on transboundary pollution at a great distance”, will not take place.

⁹⁰ <http://www.budinfo.com.ua/dbn/8.htm>

⁹¹ <http://zakon.rada.gov.ua/cgi-bin/laws/main.cgi?nreg=2707-12>

⁹² <http://zakon.rada.gov.ua/cgi-bin/laws/main.cgi?nreg=1264-12>



F.2. If environmental impacts are considered significant by the project participants or the host Party, please provide conclusions and all references to supporting documentation of an environmental impact assessment undertaken in accordance with the procedures as required by the host Party:

All working projects of gas flowlines and distribution networks to be constructed under this project will be considered and approved by the chief of the State Administration of Environment.

Impact on water medium

Impact on water medium is absent.

Impact on air environment

In the operation of project facilities air environment will be influenced by the processes of production and technological (normalized) gas losses—marginal gas leakage when it is possible to ensure reliable operation and conditional normative hermetization of gas pipelines, connecting pieces, fittings, expansion joints, gas equipment, appliances etc. In addition, the industrial-technological gas losses include leakage of gas during manufacturing, maintenance and overhaul, and gas pipe tie-in and connections, installation of fixtures, appliances, equipment that uses gas and connecting parts that do not exceed the norms of gas leakage, established by effective regulations. All the technological gas leakages are included in the project boundary and are accounted as emissions generated within the framework of the project (See Section B, D).

Impact on land use

To prevent impact on the environment during construction processes measures aimed at restoring the ecological balance are carried out. In order to reduce impact on the environment all construction and installation works are carried out exclusively within the right-of-way.

Land reclamation is planned on land:

- Trails of the pipeline across the width of the allotment;
- The territory of temporary storage of pipes and ancillary materials;
- Affected land surface on the trails of temporary roads;
- The area around ground facilities affected during construction;
- Other territories in the areas of construction, as a result of the passage of vehicles, clogged and polluted with industrial and domestic waste and oil products.

Technical reclamation of areas includes the following measures:

- Removal and preparation of soil and vegetation layer in the areas of construction;
- Cleaning of construction debris, unused materials, and all contaminants of area remained after the process of dismantling of temporary structures, bases after the completion of works on the trace;
- Restore the topsoil.

Waste generation, their treatment and disposal

According to the Ukrainian Law “On wastes”⁹³, (Article 17) “Obligations of business entities’ activity in the sphere of wastes disposal”:

- enterprises shall produce the report about formation, collection, transportation, storage, treatment, utilization, destruction and removal of wastes;

⁹³ <http://zakon2.rada.gov.ua/laws/show/187/98-BP>



- ensure complete collection, appropriate storage and prevention of wastes deterioration, for utilization of which there is corresponding technology in Ukraine.

In the process of construction activities to reduce negative impact on land resources it is provided to equip working areas and building plots with containers for household and construction waste, followed by their removal to authorized solid waste landfills.

Impact on biodiversity

There is no impact on biodiversity.

So, summing up, we can say that the project “Reduction of greenhouse gases emissions by gasification of Ivano-Frankivsk region” doesn’t have any negative effects on the environment.

**SECTION G. Stakeholders' comments****G.1. Information on stakeholders' comments on the project, as appropriate:**

In pursuance of requirements of Art. 18 of the Law of Ukraine “On planning and development of areas”⁹⁴ and Art. 11 of the Law of Ukraine “On ecological expertise”⁹⁵, PJSC “Ivano-Frankivskgas” informs the public through local media on the implementation of area planning .

All obtained comments related to the project implementation were positive. Negative comments and critical comments relating to the project were not made.

⁹⁴ <http://zakon.rada.gov.ua/cgi-bin/laws/main.cgi?nreg=1699-14>

⁹⁵ <http://zakon.rada.gov.ua/cgi-bin/laws/main.cgi?nreg=45%2F95-%E2%F0>

Annex 1**CONTACT INFORMATION ON PROJECT PARTICIPANTS****Project participant:**

Organisation:	PJSC "Ivano-Frankivskgas"
Street/P.O.Box:	Lenkavskoho Street
Building:	20
City:	Ivano-Frankivsk
State/Region:	-
Postal code:	76010
Country:	Ukraine
Phone:	+38 (0342) 50 16 22
Fax:	+38 (0342) 50 16 02
E-mail:	boss@gaz.if.ua
Represented by:	
Title:	Chairman of the Board
Salutation:	Mr
Last name:	Prokopiv
Middle name:	Bogdanovich
First name:	Ihor
Department:	
Fax (direct):	+38 (0342) 50 16 22
Phone (direct):	+38 (0342) 50 16 02
Mobile:	
Personal e-mail	boss@gaz.if.ua

Potential ERUs purchaser:

Organisation:	CEP Carbon Emissions Partners S.A.
Street/P.O.Box:	Route de Tonon
Building:	52
City:	Geneva
State/Region:	
Postal code:	Case postale 170 CH-1222 Vérenaz
Country:	Switzerland
Phone:	+41 (76) 346 11 57
Fax:	+41 (76) 346 11 57
E-mail:	0709bp@gmail.com
Represented by:	
Title:	Director
Salutation:	Mr.
Last name:	Knodel
Middle name:	
First name:	Fabian
Department:	
Fax (direct):	+41 (76) 346 11 57
Phone (direct):	+41 (76) 346 11 57
Mobile:	+41 (76) 346 11 57
Personal e-mail	

Annex 2**BASELINE INFORMATION**

The baseline was set according to a specific approach to the Joint Implementation (JI) projects, relying on “Guidance on criteria for baseline setting and monitoring”, for the Joint Implementation Project Version 03⁹⁶.

Summarized information on key elements of the baseline is presented in the table, which is given below:

Parameter	Description of the parameter	Measured (m), calculated (c), estimated (e)	Value (for the fixed parameter)	Source of data
$FC_{NG,i,y}$	Total quantity of natural gas combusted in period “y” by a consumer, ths m ³	m	N/A	Gas meters
$NCV_{FF,y}$	Net calorific value of fossil Fuel of “FF” type (Fuel of “FF” type means coal, fuel oil), GJ/t	e	See Section B.1	The “National inventory report of anthropogenic greenhouse gas emissions by sources and removals by sinks in Ukraine for 1990-2010” ⁹⁷ . Data on the type of fossil fuel used by a consumer before the gasification are provided by district administrations and village councils.
$NCV_{NG,y}$	Net calorific value of natural gas, GJ/ ths m ³	e	See Section B.1.	The “National inventory report of anthropogenic greenhouse gas emissions by sources and removals by sinks in Ukraine for 1990-2010” ⁹⁸ ,
$OXID_{FF,y}$	Carbon oxidation factor in the course of fossil fuel of “FF” type combustion	e	See Section B.1.	Carbon oxidation factor when combusting fossil fuel is used to

⁹⁶http://ji.unfccc.int/Ref/Documents/Baseline_setting_and_monitoring.pdf

⁹⁷http://unfccc.int/files/national_reports/annex_i_ghg_inventories/national_inventories_submissions/application/zip/ukr-2012-nir-13apr.zip

⁹⁸http://unfccc.int/files/national_reports/annex_i_ghg_inventories/national_inventories_submissions/application/zip/ukr-2012-nir-13apr.zip



	(Fuel of “ <i>FF</i> ” type means coal, fuel oil), relative units			determine on default carbon dioxide emission factor for stationary combustion of fossil fuels in Ukraine. The data source for this parameter is the “National inventory report of anthropogenic greenhouse gas emissions by sources and removals by sinks in Ukraine for 1990-2010” ⁹⁹ .
$EF_{C,FF,y}$	Carbon emission factor in the course of fossil fuel of “ <i>FF</i> ” type combustion. (Fuel of “ <i>FF</i> ” type means coal, fuel oil), t C/TJ	e	See Section B.1.	The “National inventory report of anthropogenic greenhouse gas emissions by sources and removals by sinks in Ukraine for 1990-2010” ¹⁰⁰
$\eta_{PJ,i}$	Efficiency of stationary natural gas combustion at the site of consumer “ <i>i</i> ”, relative units	e	See section B 1.	Detailed calculation is provided in Supporting Document 3.
$\eta_{BL,i}$	Efficiency of stationary coal or fuel oil combustion at the site of consumer “ <i>i</i> ”, relative units	e	See section B 1.	The parameter is used according to the approved CDM methodology ACM0009 “Consolidated baseline and monitoring methodology for fuel switching from coal or petroleum fuel to natural gas” - Version 4.0.0 ¹⁰¹

⁹⁹ http://unfccc.int/files/national_reports/annex_i_ghg_inventories/national_inventories_submissions/application/zip/ukr-2012-nir-13apr.zip

¹⁰⁰ http://unfccc.int/files/national_reports/annex_i_ghg_inventories/national_inventories_submissions/application/zip/ukr-2012-nir-13apr.zip

¹⁰¹ <http://cdm.unfccc.int/methodologies/DB/49516CYT8X8LZ3F4YRXKSIHRXMOTR5>



The baseline is set by using the specific approach based on approved methodology ACM0009 ACM0009 “Consolidated baseline and monitoring methodology for fuel switching from coal or petroleum fuel to natural gas” - Version 4.0.0¹⁰².

¹⁰² <http://cdm.unfccc.int/methodologies/DB/49516CYT8X8LZ3F4YRXKSIHRXMOTR5>

Annex 3**MONITORING PLAN**

An approach for baseline setting and monitoring developed according to Appendix B of the JI guidelines, namely specific JI approach was used to determine the monitoring methodology. The monitoring plan for this project was established in accordance with “Guidance on criteria for baseline setting and monitoring”, for the Joint Implementation Project Version 03¹⁰³.

Monitoring plan provides for the following measures:

1. Identification of all potential sources of emissions within the project.
2. Collection of information on greenhouse gas emissions within the project during the crediting period.
3. Assessment of the project implementation schedule.
4. Collection of the information on measurement equipment, its calibration.
5. Collection and archiving information on the impact of project activities on the environment.
6. Data archiving.
7. Determination of the structure of responsibility for project monitoring.
8. Analysis of organization of personnel training.

Calculation of reduced GHG emission factor when transporting natural gas to end consumers.

$$EF_{CO_2,GTU,y} = \frac{PE_{GTU,y}}{FC_{NG,y}}$$

- $EF_{CO_2,GTU,y}$ - reduced GHG emission factor when transporting natural gas to end consumers, t CO₂e/ m³
- $FC_{NG,y}$ - total volume of transit natural gas transported through Ukraine in year “y”. (according to the Ministry of Energy and Coal Industry of Ukraine¹⁰⁴) bln m³;
- $PE_{GTU,y}$ - total amount of CO₂ that is released when transporting natural gas to end consumers, tCO₂.

$$PE_{GTU,y} = \frac{44}{12} * HC_y * EF_{C,NG,y} * OXID_{NG,y}$$

- HC_y - total quantity of heat spent on transporting of natural gas through Ukraine, TJ. (according to data from the “National inventory report of anthropogenic emissions by sources and removals by sinks of greenhouse gases in Ukraine for 1990-2010”¹⁰⁵, Table 1 A(a)s3)
- $EF_{C,NG,y}$ - Carbon emission factor when combusting natural gas, t C/TJ;
- $OXID_{NG,y}$ - Carbon oxidation factor when combusting natural gas, relative units.

Calculations are based on approved national data of the Ministry of Energy and Coal Industry of Ukraine and data from the “National inventory report of anthropogenic greenhouse gas emissions by sources and

¹⁰³http://ji.unfccc.int/Ref/Documents/Baseline_setting_and_monitoring.pdf

¹⁰⁴http://mpe.kmu.gov.ua/fuel/control/uk/publish/category?cat_id=35081

¹⁰⁵http://unfccc.int/files/national_reports/annex_i_ghg_inventories/national_inventories_submissions/application/zip/ukr-2012-nir-13apr.zip



removals by sinks in Ukraine for 1990-2010¹⁰⁶. Frequency of monitoring of data is annual. Detailed calculations are provided in Supporting Document 1.3 (Excel file).

Table 29. Annual total transit natural gas transported through Ukraine in 2004-2012 (according to the Ministry of Energy and Coal Industry of Ukraine¹⁰⁷)

Total volume of transit natural gas transported through Ukraine m ³ of gas, $FC_{NG,y}$ bln m ³				
2004	2005	2006	2007	2008
137.1	101.9	128.5	115.2	109.9
2009	2010	2011	2012	
95.2	98.6	104.2	104.2	

Table 30. Annual amount of heat spent on natural gas transportation through Ukraine in 2004-2012, TJ (according to data from the "National inventory report of anthropogenic emissions by sources and removals by sinks of greenhouse gases in Ukraine for 1990-2010"¹⁰⁸)

Total quantity of heat energy (obtained by natural gas combustion), necessary for transporting of natural gas in gas distribution networks of Ukraine, TJ				
2004	2005	2006	2007	2008
180 401	176 724	165 090	140 318	148 018
2009	2010	2011	2012	
99 552	87 352	87 352	87 352	

¹⁰⁶

http://unfccc.int/files/national_reports/annex_i_ghg_inventories/national_inventories_submissions/application/zip/ukr-2012-nir-13apr.zip

¹⁰⁷ http://mpe.kmu.gov.ua/fuel/control/uk/publish/category?cat_id=35081

¹⁰⁸ http://unfccc.int/files/national_reports/annex_i_ghg_inventories/national_inventories_submissions/application/zip/ukr-2012-nir-13apr.zip