

THE JOINT IMPLEMENTATION PROJECT

Dismantling of waste heap №2 at mine №22 "Lisova"

Financial Director

SIA "Vidzeme Eko"  
(position)



(signature)

Aleksandrs Fridkins  
(name)

Director

"TH "Metalprom"  
(position)



(signature)

Gazizov Roman V.  
(name)

Kyiv  
April 2012



**JOINT IMPLEMENTATION PROJECT DESIGN DOCUMENT FORM**  
**Version 01 - in effect as of: 15 June 2006**

**CONTENTS**

- A. General description of the project
- B. Baseline
- C. Duration of the project / crediting period
- D. Monitoring plan
- E. Estimation of greenhouse gas emission reductions
- F. Environmental impacts
- G. Stakeholders' comments

**Annexes**

Annex 1: Contact information on project participants

Annex 2: Baseline information

Annex 3: Monitoring plan

Annex 4: Calculation the cost of electricity for the processing technology of rock on the beneficiation plant

**SECTION A. General description of the project****A.1. Title of the project:****Dismantling of waste heap #2 at mine #22 "LISOVA"**

Sectoral scope: 8. Mining/mineral production

PDD version 2.0

dated 03/05/2012

**A.2. Description of the project:***General description of the sector, company and activities*

Dump (waste heap) is an integral part of the landscape of the Donbas region. In the Donetsk Basin there is one of the largest deposits of coal in the world (Ukraine by geological reserves of fossil coal ranks first in Europe and eighth in the world). Coal production in Donbass is carried out mostly by mine way and has 300-year history. The total basin area is about 60 th. km<sup>2</sup> and covers the territory of Dnipropetrovsk, Donetsk and Lugansk regions. Stocks of coal up to a depth of 1800 m are about 140.8 billion tons<sup>1</sup>. Coal beds occur at medium (400 - 800 m) and large (over 1000 m) depths and in most cases have little power (about 0,6-1,2 m). Coal layers are alternating with the usual rock (shale, sandstone, limestone). Coal mining is accompanied, therefore, with lifting to the surface the large amount of rock.

Rocks that are sent into the dump, are formed by shaft sinking (52%) and repair (48%). These "empty" rocks stored near mine shafts in the form of heaps up to 60-80 m and vertebral dumps (amounting to 92%), at least - flat dump (8%)<sup>2</sup>. Dumps of Donbass cover an area of over 7000 hectares.

Most of the coal is produced by large coal-mining unions of different ownership. Along with them there are small private companies involved in coal extraction and its processing (sorting, enrichment) and fuel trade.

LLC "Trading House "Metalprom" engaged in wholesale fuel, has considerable experience in excavation and mining, as well as in land reclamation and landscaping. LLC " Trading House "Metalprom" uses the dump #2 of mine #22 "Lisova" in a legitimate basis.

*Situation before the proposed project start*

By-product of continuous operation of coal mines is the formation of conic dumps of coal rocks - heaps. Smoldering and burning waste heap is a fundamental factor in violation of environmental and economic balance of Donbass mining areas, causing the formation of a complicated ecological situation, which affects the state of the atmosphere, soil, water objects, leading to degradation of natural landscapes and detrimental to health and people life.

The process of enrichment at the mines was not very effective, there are not considered economically feasible to extract 100% of the coal rocks that rose to the surface. Consequently, the dumps of Donbass, especially formed in 60-70 years, contain large amounts of coal. Examined mine waste heaps mass has an ash content within 57-99%, accounting for an average of 88.5%. Humidity varies from 0.2% to 11.7%, accounting for an average of 3.4%<sup>3</sup>. However, coal content even within the same waste heap undergoes significant fluctuations and poorly predicted. There is a possibility that much of the rock dump may contain a small amount of coal, while another part has a high concentration of coal mass and increased susceptibility to spontaneous combustion. Over time, almost all dumps, that contain coal, are very susceptible to spontaneous ignition and self-sustained combustion. Those dumps, that are currently burning or are at risk of ignition, are the sources of uncontrolled emission of greenhouse gases and hazardous substances. Oxidation and burning of rocks is accompanied by emission of a wide range of volatile components that stand out from rock mass, enriched by coal substance. Hot waste heaps produce steam,

<sup>1</sup> BS Busygin, Dr. Sc. Sciences, prof., EL Sergejev. Monitoring data of Donbass heaps by multispectral satellite imagery. ISSN 2071-2227, Naukovy Visnyk of the NGU, 2011, № 2

<sup>2</sup> [http://www.ipages.ru/index.php?ref\\_item\\_id=2607&ref\\_dl=1](http://www.ipages.ru/index.php?ref_item_id=2607&ref_dl=1)

<sup>3</sup> [http://www.ipages.ru/index.php?ref\\_item\\_id=2607&ref\\_dl=1](http://www.ipages.ru/index.php?ref_item_id=2607&ref_dl=1)



which also may contain water and sulfuric acid (sulfate ion), carbon dioxide, nitrogen dioxide (nitrate ion). With a lack of oxygen in the vapour and gas emissions are hydrogen sulfide, hydrocarbons, ammonia, carbon monoxide. Water erosion of heap causes in leaching of toxic components and contamination of soil and groundwater, spreading them over long distances. Thus, the role of waste heaps in the ecology of the region is extremely negative, increasing many times at his burning. However, an outbreak and its very possibility is difficult to forecast, we can only estimate the probability of ignition, which is very high, based on statistics. You can say that most waste heaps, sooner or later ignited. The process of combustion of carbon in the dumps is long enough and lasts 5-7 years<sup>4</sup>.

Despite the fact that the owners of waste heaps obliged to take measures to prevent their burning, immediate quenching the rock dumps is not common practice in the Donbass region. Fines paid by pollution costs much less than money spent on measures to prevent ignition or burning. In the baseline scenario assumed that the common practice will be continued - heap may be spontaneously ignited with a certain probability, and the process of burning will continue while the all coal, contained therein, will burn. The process of combustion is accompanied by release the carbon dioxide into the atmosphere.

Proposed project provides a complete dismantling of the dump #2 at mine #22 "Lisova". During dismantling of dump it will be dismantling of the rock mass by special technics, loading into trucks, and transportation to the beneficiation factory LLC "PC" Donetsk coal fuel" for further enrichment, in which the coal concentrate will be obtained. This product is further directed to boiler houses for burning as fuel. Thus, rock mass of dump will be fully utilized, and the received coal will replace coal, which must be produced by mine way. As the result of project, the opportunity of self-ignition of heap will be eliminated.

An important component of the project is its second phase - complex reclamation of area by restoring its fertile layer and the full restoration of natural ecological community. This part of the project is required, but totally expensive, due to this mechanism of joint implementation was one of the prominent factors of the project from the beginning, and financial benefits as part of this mechanism considered one of the reasons of the project implementation.

### A.3. Project participants:

Table 1 - Project participants

<u>Party involved</u>	<u>Legal entity project participant</u> (as applicable)	Please indicate if the <u>Party involved</u> wishes to be considered as <u>project participant</u> (Yes/No)
Ukraine (Host party)	LLC " Trading House "Metalprom"	No
Republic of Latvia	SIA "Vidzeme Eko"	No

.The role of project participants:

- LLC "TH "Metalprom"- a legal entity, that operates lawfully the dump #2 of mine #22 "Lisova ", and introduces the proposed JI project;
- SIA "Vidzeme Eko " responsible for the preparation of the PDD, obtaining approvals from the parties, monitoring and transfer of ERUs generated / AAUs.

See detailed information on project participants in Annex 1.

<sup>4</sup> <http://ji.unfccc.int/UserManagement/FileStorage/IE7LK2SZF1NOXRVB4CYG65WQPJMHA3>





**A.4. Technical description of the project:**

Technical description of the project, as well as detailed information on the location of the project, are given below in sections from A.4.1. to A.4.3.

**A.4.1. Location of the project:**

Waste heap #2 of mine #22 "Lisova"

**A.4.1.1. Host Party(ies):**

Ukraine

**A.4.1.2. Region/State/Province etc.:**

Donetsk region, Torez district



Figure 1 - Location of the project on the map of Ukraine

**A.4.1.3. City/Town/Community etc.:**

Urban village Pelagiyvka





**A.4.1.4. Detail of physical location, including information allowing the unique identification of the project (maximum one page):**

Complex for sorting rock dump is located on the industrial site of the mine #22 "Lisova" on the northeast end of u.v. Pelagyivka

Location of project: 48° 06' 56" N. Lt. and 38° 37' 00" E. Lg.



Figure 2 - The exterior of the waste heap #2 of mine #22 "Lisova" under stage of dismantling

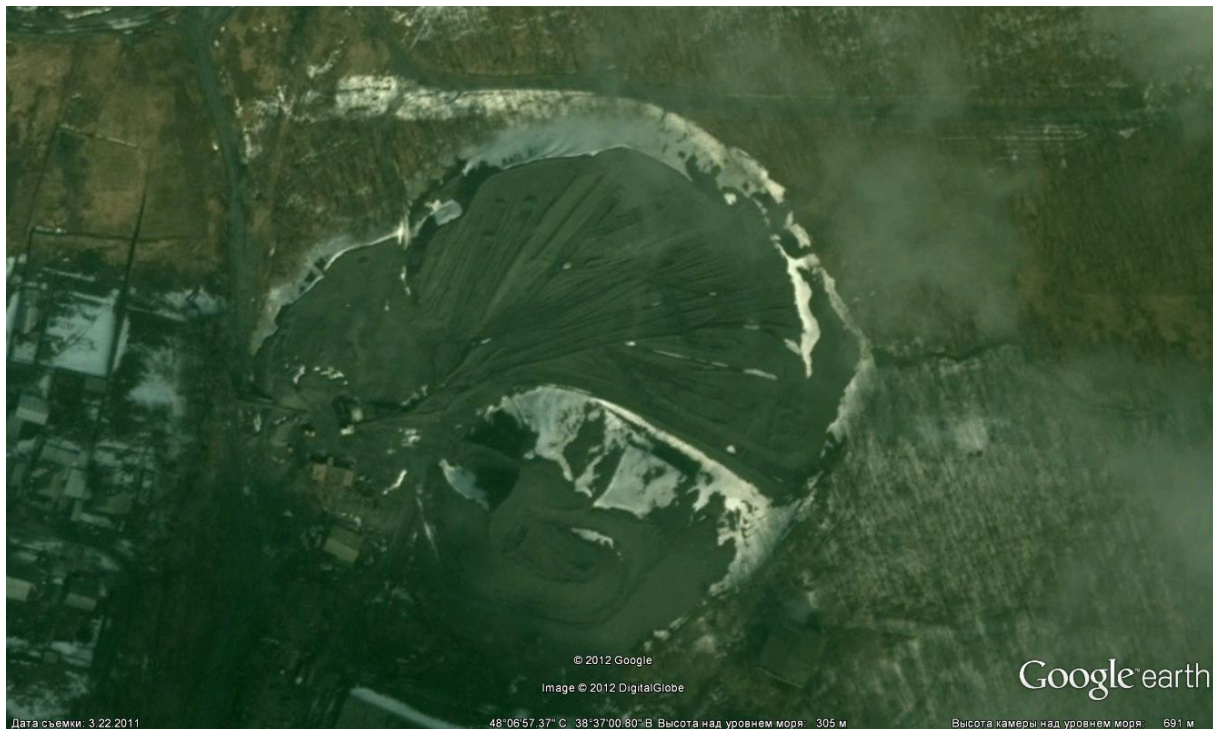

Figure 3 - Heap #2 of mine #22 "Lisova" under dismantling, the appearance from the satellite

**A.4.2. Technology(ies) to be employed, or measures, operations or actions to be implemented by the project:**

The project provides the most rational in terms of capital costs scheme of dismantling of dump, which supposed the application to dump only special equipment that provides dismantling of dump and loading carbonaceous rock mass at vehicles for further delivery to beneficiation factory.

Excavators, bulldozers, and cargo vehicles ( trucks) are involved in dismantling of the dump.

Dismantling of dump is made by NPAOP 10.0-5.21-04 "Instruction to prevent spontaneous combustion, fire and dismantling dumps"<sup>5</sup> the following combined technology:

Bulldozers rise to the top of blade on its tail section. Dismantling of dump by bulldozers T-170 (operational capacity of 132 kW, the specific fuel consumption at capacity, 218 g / kWh)<sup>6</sup> occurs by horizontal layers. After lowering the height of dump to 25-30 m, dismantling by slope (15 °) layers allowed.



Figure 4 - Special Machinery. Bulldozer T-170

A combined method of dismantling dumps is used, when after layerwise lowering by bulldozer to the height, at which entrance road can be constructed, further dismantling is carried out by excavator EO-5126 (1.8 m<sup>3</sup> bucket capacity, operational capacity of 132 kW, the specific fuel consumption for operating capacity 220 kg / kW)<sup>7</sup> with direct load of rocks into vehicles (trucks KAMAZ 55111, carrying capacity 13 tons, 162 kW engine power, fuel consumption 39 l/100 km)<sup>8</sup>. The design capacity of dismantling complex allowed to process 700 thousand tons of rock mass per year.

<sup>5</sup> <http://document.ua/instrukcija-iz-zapobigannja-samozapalyvannyu-gasinnja-ta-ro-nor2799.html>

<sup>6</sup> [http://www.stroygruz.ru/arenda-tex/buldozer\\_t\\_170.html](http://www.stroygruz.ru/arenda-tex/buldozer_t_170.html)

<sup>7</sup> [http://www.uraltehnika.ru/opisanie/ekskavatory/eo\\_5126](http://www.uraltehnika.ru/opisanie/ekskavatory/eo_5126)

<sup>8</sup> <http://www.politechsnaab.ru/kamaz/kamaz55102.php>





Figure 5 - Special Machinery. Excavator EO-5126, truck Kamaz 55111

In the second stage the rock mass is further supplied to a special beneficiation factory - LLC "PC" Donetsk coal fuel ". Address - Donetsk region., t.Dimitrov, Lenin Street 12, geographic coordinates: 48° 18'08" N. Lt, 37 °15'41" E.Ln. Rock mass enters on the inertial screening sifter for the pre-classification by class of 100 mm. After the pre-classification, the coal mass delivered to the preparatory screening to sifter HYL-52a<sup>9</sup> (by dry or wet mode). Beneficiation of large class 13 mm is made on heavy media separator SKV-20<sup>10</sup>, and Beneficiation of small class 3-13 mm - at hydrocyclone GT-710<sup>11</sup>. Next, it takes place washing suspension of beneficiation products and dehydrating products by dressing screens and centrifuge, regeneration suspension at electromagnetic separator. Thus the water in this process is used in closed loop. Beneficiation products (coal concentrate) are transported by conveyor belt into bins for further shipment to the consumer. Waste transported on flat dump



Figure 6 - Separator SKV-20

<sup>9</sup> <http://www.zaoplatov.ru/equipment/miner?n=213>

<sup>10</sup> [http://www.gmuo.com.ua/files\\_ru/separat/skv.htm](http://www.gmuo.com.ua/files_ru/separat/skv.htm)

<sup>11</sup> [http://www.gmuo.com.ua/files\\_ru/separat/skv.htm](http://www.gmuo.com.ua/files_ru/separat/skv.htm)



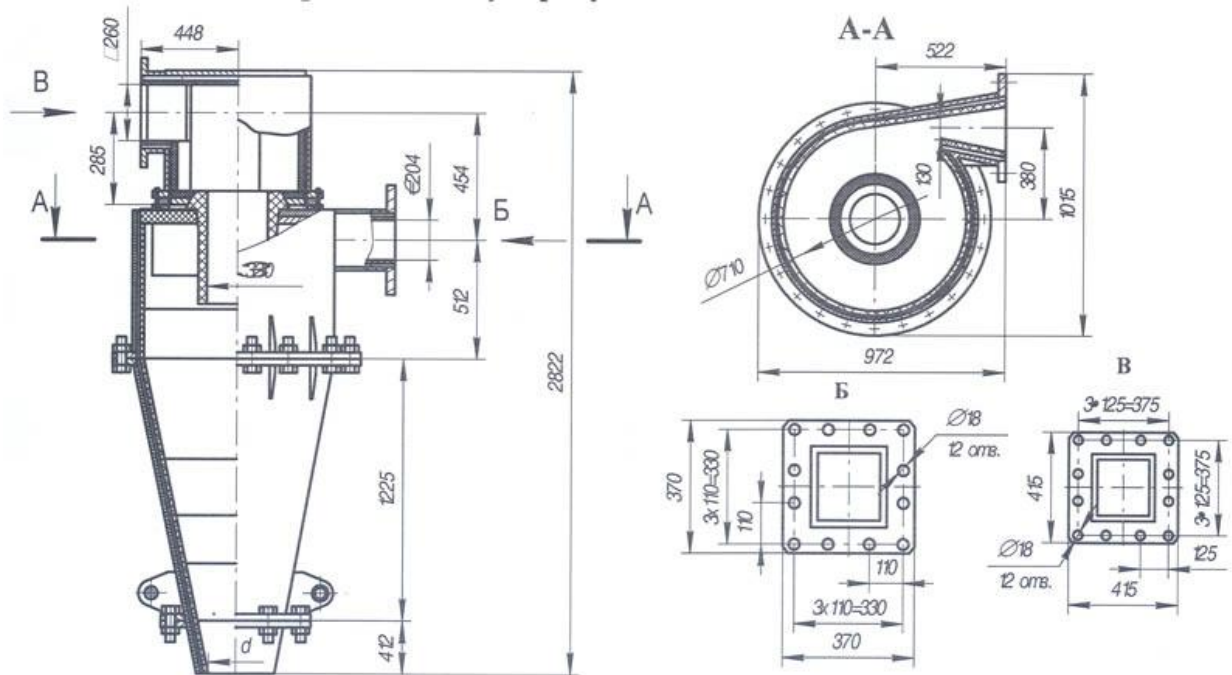

Figure 7 - Hydrocyclone GT-710

The first phase of the project - dismantling of rock dump has began at October 23, 2009, the second stage - the reclamation of land is planned to start at the second half of 2012 and finish by the end of 2012.

**A.4.3. Brief explanation of how the anthropogenic emissions of greenhouse gases by sources are to be reduced by the proposed JI project, including why the emission reductions would not occur in the absence of the proposed project, taking into account national and/or sectoral policies and circumstances:**

The project activities aimed at extracting coal from the dump #2 of the mine #2 "Lisova" to prevent emissions into the atmosphere when spontaneous burning of dumps occur and receiving more quantity of coal. Rock mass delivered for enrichment at beneficiation factory with aim of receiving the steam coal and subsequent combustion at boiler houses. It is planned to achieve maximum rates of dismantling in the Kyoto period.

After the final sorting of dump it is planned reclamation of land with restoration of vegetation layer. After the restoration of vegetation layer it will be made planting grass, trees and shrubs characteristic for climatic zone of Donbass.

The problem of waste heaps is very crucial at this time in the Donbass. Waste heaps not only derive considerable land area from economic turnover and lead to disruption of ecological balance of natural biological community, but also are a source of high environmental hazard. Even at non-burning condition heap is a source of pollution of air, soil, nearby water bodies and groundwater. This risk is increased many times by burning waste heaps<sup>12</sup>. The only way to eliminate the harmful effects of heap on the environment is its complete dismantling. However, the process of dismantling of heap is a very costly process, which economic benefit is not offset possible costs. In addition there are significant risks associated with the inability to timely determination of coal in total volume of waste heap. Significant costs bears followed after dismantling renewal of fertile layer and reclamation of earth area. This leads to a situation where the process of dismantling of heap facing financial difficulties, and for its successful implementation it is necessary search for additional sources of funding. Receipt of additional income from the sale of quotas under the Joint Implementation project provides a powerful incentive for successful completion of this project.

<sup>12</sup> [http://terrikon.donbass.name/ter\\_s/290-model-samovozgoraniya-porodnyx-otvalov-ugolnyx-shax-t-donbassa.html](http://terrikon.donbass.name/ter_s/290-model-samovozgoraniya-porodnyx-otvalov-ugolnyx-shax-t-donbassa.html)



Processing of these dumps will avoid burning, improve ecological situation in the region, significantly reduce emissions of CO<sub>2</sub> and other harmful substances. Dismantling of rock dumps will reduce the probability of groundwater contamination. The area of land for agricultural activities and for other purposes will increase. Also you get an extra amount of coal that does not need to produce, thus able to avoid leaks of methane, which is accompanied by a coal mine way. Emission reductions can be sold as ERUs on the international market of emissions trading.

The proposed project is aimed at reducing anthropogenic emissions. Emission reductions created by:

- Eliminate sources of greenhouse gases associated with burning waste heaps, by extracting coal from the rock dumps;
- Reduce uncontrolled emissions of methane due to replacement of coal that would have been extract mine way;
- Reduce electricity consumption at waste heap dismantling in comparison with electricity consumption at coal mine.

Efforts to stop dumps burning and full their dismantling corresponds to the current legislation of Ukraine on the environmental protection. The proposed project is evaluated positively by local authorities. Detailed description of the baseline and additionality contained in Section B of the project documentation.

#### **A.4.3.1. Estimated amount of emission reductions over the crediting period:**

Table 2 - The total expected emission reductions over the crediting period

	Years
Length of the <u>crediting period</u>	3 years 2 months
Year	Estimate of annual emission reductions in tonnes of CO <sub>2</sub> equivalent
From 23/10/2009	103267
2010	438747
2011	465962
2012	299767
Total estimated emission reductions over the <u>crediting period</u> (tonnes of CO <sub>2</sub> equivalent)	<b>1307743</b>
Annual average of estimated emission reductions over the <u>crediting period</u> (tonnes of CO <sub>2</sub> equivalent)	<b>412971</b>

#### **A.5. Project approval by the Parties involved:**

Project Idea (PIN) was submitted to the Designated Coordinating Center (National Environmental Investment Agency) at March 23, 2012. Letter of support number 1154/23/7 was given 28/04/2012 by NEIA that supports further development of the proposed project. Expected to get letters of approval from NEIA and letter of approval from a foreign country in May 2012.

**SECTION B. Baseline****B.1. Description and justification of the baseline chosen:**

The baseline for a JI project should be brought into compliance with Annex B to Decision 9/CMP.1 ("Guidelines for the implementation of Article 6 of the Kyoto Protocol")<sup>13</sup>, and according to the "Guidance On Criteria For Baseline Setting And Monitoring, Version 0.3"<sup>14</sup> (hereinafter - the "Guidelines") issued by the supervisory JI (JISC).

Under the Guidance, the baseline for a JI project is a scenario that objectively represents the anthropogenic emissions of GHG sources or anthropogenic GHG removals by the acquisition, which could occur in the absence of the proposed project. In accordance with paragraph 9 of the Guidance, the project participants may choose either approach the criteria for establishing the baseline and monitoring, designed in accordance with Annex B of the Guidance or method for determining the baseline setting and monitoring adopted by the Executive Committee of the clean development mechanism (CDM).

Article 11 of Guidance allows project participants to choose an approach to JI projects, or use the combination of approved methodologies for CDM baseline or approved CDM methodological tools. For description and justification of the baseline the following step by step approach used:

**Step 1: Indication and description of the approach chosen regarding baseline setting**

The baseline of this project is defined on a special project basis in accordance with Article 21 of the JISC Guidance. Can not be used multi-project emission factor or sectoral baseline, because the project under consideration is one of the few of its kind, both in the sector (mining of rock dumps in Ukraine) as well as among JI projects.

According to Article 9 of the JISC Guidance, Option A selected for determining the baseline: *(a) An approach for determining the baseline and monitoring designed in accordance with Annex B of JI Guidelines (JI specific approach);*

Under Article 11 of Guidance for setting the baseline the latest version of the current methodology is used, which have chosen in the project " Waste heaps dismantling with the aim of decreasing the greenhouse gases emissions into the atmosphere. ", which is published on the website of the UNFCCC<sup>15</sup>.

The most likely future scenarios will be identified by checking whether all alternatives to meet the applicable law and regulations, and by analyzing the barriers. If only two alternatives remained, one of which represents the project scenario without the JI incentive, you must use Tools Clean Development Mechanism (CDM) "Tool for demonstration and assessment of additionality" to prove that the project scenario cannot be regarded as the most plausible.

**Step 2. Application of the approach chosen**

Plausible future scenarios will be identified in order to establish a baseline.

***Sub step 2a. Identifying and listing plausible future scenarios.*****Scenario 1. Continuation of existing situation**

In the current situation waste heaps are not utilized. Spontaneous self-heating and subsequent burning of waste heaps is very common and measures to extinguish fire are taken sporadically. Burning waste heaps are sources of uncontrolled greenhouse gas emissions. Coal is not extracted from the waste heaps. Coal is produced by underground mines of the region and used for energy production or other purposes. Coal mining activities cause emissions of fugitive methane and also the formation of new waste-heaps.

<sup>13</sup> <http://unfccc.int/resource/docs/2005/cmp1/eng/08a02.pdf>

<sup>14</sup> [http://ji.unfccc.int/Ref/Documents/Baseline\\_setting\\_and\\_monitoring.pdf](http://ji.unfccc.int/Ref/Documents/Baseline_setting_and_monitoring.pdf)

<sup>15</sup> <http://ji.unfccc.int/UserManagement/FileStorage/IE7LK2SZF1NOXRVB4CYG65WQPMHA3>



Scenario 2. Direct energy production from the heat energy of burning waste heap

Waste heaps are not extinguished and not monitored properly. Some burning heaps are used to produce energy by direct insertion of heat exchangers into the waste heap<sup>16</sup>. This captures a certain amount of heat energy for direct use or conversion into electricity. The coal is not extracted from the waste heaps. Coal is produced by underground mines of the region and used for energy production or other purposes.

Mining activities, resulting in fugitive gas release, and the formation of more waste-heaps.

Scenario 3. Production of construction materials from rock dumps.

Waste heaps are being processed in order to produce construction materials (bricks, panels, etc.). Coal in the waste heap matter is burnt during the agglomeration process<sup>17</sup>. Coal is produced by underground mines of the region and used for energy production or other purposes. Mining activities, resulting in fugitive gas release, and the formation of more waste-heaps.

Scenario 4. Coal extraction from waste heaps without JI incentives

This scenario is similar to the project activity only in this case the project does not benefit from the possible development as a joint implementation project. In this scenario waste heaps are processed in order to extract coal and used it the energy sector. Less coal is produced by underground mines of the region.

Scenario 5. Systematic monitoring of waste heaps condition and regular fire prevention and extinguishing measures

Waste heaps are systematically monitored and their thermal condition is researched. Regular fire prevention measures are taken. In case of a burning waste heap, the fire is extinguished and measures are taken to prevent burning in the future. Coal is not extracted from the waste heaps. Coal is produced by underground mines of the region and used for energy production or other purposes. Mining activities, resulting in fugitive gas release, and the formation of more waste-heaps.

***Sub step 2b. Consistency with mandatory applicable laws and regulations.***

Existing Ukrainian laws and regulations treat waste heaps as sources of possible dangerous emissions into the atmosphere. In general burning waste heaps should be extinguished and measures must be taken to prevent fires in the future. However, due to the large numbers of waste heaps and their substantial sizes, combined with the limited resources of the owners, they typically do not even undertake the minimum required regular monitoring. Even when informed of a burning waste heap, and measures have to be taken under existing legislation, it is more typical to accept the fine for air contamination, rather than take action to extinguish the burning waste heap itself.

Monitoring of dumps is not conducted systematically, and all activities are at the discretion of the owner of dumps. Basically dumps are in ownership of mines or regional coal association. Coal mines of Ukraine are suffering from limited investment, which often leads to security problems due to severe conditions of production and financial difficulties, including the wages of miners often delayed for several months. In this case dumps are considered as an additional burden, but mine usually do not make even minimum measures required. Ignition and burning heaps are very common, and investigated 373 of the dumps in the

---

<sup>16</sup> *Method to utilize energy of the burning waste heaps*, Melnikov S.A., Zhukov Y.P., Gavrilenko B.V., Shulga A.Y., State Committee Of Ukraine For Energy Saving, 2004

<http://masters.donntu.edu.ua/2004/fgtu/zayanchukovskaya/library/artcl3.htm>

<sup>17</sup> *Opportunities for international best practice use in coal mining waste heap utilization of Donbas*, Matveeva N.G., Ecology: Collection of Scientific Papers, Eastern Ukrainian National University, Luhansk, #1 2007  
[http://www.nbu.gov.ua/portal/natural/Ecology/2007\\_1/Article\\_09.pdf](http://www.nbu.gov.ua/portal/natural/Ecology/2007_1/Article_09.pdf)

**Joint Implementation Supervisory Committee**

page 13

Donetsk region, only 22 relatively precisely known, they are not burned, to the same exact data are not always available<sup>18</sup>.

In such circumstances it is safe to say that all scenarios do not contradict existing laws and regulations.

***Sub step 2c. Barrier analysis*****Scenario 1. Continuation of existing situation**

This scenario does not anticipate any activities and therefore does not face any barriers.

**Scenario 2. Direct energy production from the heat energy of burning waste heap**

*Technological barrier:* This scenario is based on the highly experimental technology, which has not been implemented even in a pilot project. It is also not suitable for all waste heaps as the project owner will have to balance the energy resource availability (i.e. waste heap location) and the location of the energy user. On-site generation of electricity addresses this problem but requires additional interconnection engineering. In general this technology has yet to prove its viability. In addition it does not allow the control and management of the emitted gases.

*Investment barrier:* Investment into unproven technology carries a high risk. In case of Ukraine, which carries a high country risk, investment into such unproven energy projects are less likely to attract investors than some other opportunities in the energy sector with higher returns. The pioneering character of the project may appeal to development programmes and governmental incentives but cost of the produced energy is likely to be much higher than alternatives.

**Scenario 3. Production of construction materials from waste heap matter**

*Technological barrier:* This scenario is based on known technology, however, this technology is not currently available in Ukraine and there is no evidence that such projects will be implemented in the near future. It is also not suitable for all types of waste heaps as the content of waste heap has to be predictable in order for project owner to be able to produce quality materials. High contents of sulphur and moisture can reduce the suitability of the waste heap for processing. A large scale deep exploration of the waste heap has to be performed before the project can start.

**Scenario 4. Coal extraction from waste heaps without JI incentives**

*Investment barrier:* This scenario is financially unattractive and faces barriers. Please refer to section B.2 for details.

**Scenario 5. Systematic monitoring of waste heaps condition and regular fire prevention and extinguishing measures**

*Investment barrier:* This scenario does not represent any revenues but anticipates additional costs for waste heaps owners. Monitoring of the waste heap status is not done systematically and in general actions are left to the discretion of the individual owners. Waste heaps are mostly owned by mines or regional coal mining associations. Coal mines in Ukraine suffer from limited investment resulting often in safety problems due to complicated mining conditions and financial constraints, with miners' salaries often being delayed by few months. Waste heaps in this situation are considered as additional burdens and mines often do not even perform minimum required maintenance. Spontaneous self-heating and subsequent burning of waste heaps is very common and among 594 surveyed waste heaps in Donetsk region alone, only 20 are known not to have been burning at sometime, exact data are not always available. From a commercial view point the fines that are usually levied by the authorities are considerably lower than costs of all the measures outlined by this scenario.

***Sub step 2d. Baseline identification***

---

<sup>18</sup> Report on the fire risk of Donetsk Region's waste heaps, Scientific Research Institute "Respirator", Donetsk, 2012.

**Joint Implementation Supervisory Committee**

page 14

All scenarios, except Scenario 1 - Continuation of existing situation, face prohibitive barriers. Therefore, continuation of existing situation is the most plausible future scenario and is the baseline scenario.

This baseline scenario has been established according to the criteria outlined in the JISC Guidance:

- 1) On a project specific basis. This project is the first of its kind and therefore other options could not be used;
- 2) In a transparent manner with regard to the choice of approaches, assumptions, methodologies, parameters, data sources and key factors. All parameters and data are either monitored by the project participants or are taken from sources that provide a verifiable reference for each parameter. Project participants use approaches suggested by the JISC Guidance and methodological tools provided by the CDM Executive Board;
- 3) Taking into account relevant national and/or sectoral policies and circumstances, such as sectoral reform initiatives, local fuel availability, power sector expansion plans, and the economic situation in the project sector. It is demonstrated by the above analysis that the baseline chosen clearly represents the most probable future scenario given the circumstances of modern day Donetsk coal sector;
- 4) In such a way that emission reduction units (ERUs) cannot be earned for decreases in activity levels outside the project activity or due to force majeure. According to the proposed approach emission reductions will be earned only when project activity will generate coal from the waste heaps, so no emission reductions can be earned due to any changes outside of project activity.
- 5) Taking account of uncertainties and using conservative assumptions. A number of steps have been taken in order to account for uncertainties and safeguard conservativeness:
  - a. Same approaches as used for the calculation of emission levels in the National Inventory Reports (NIRs) of Ukraine are used to calculate baseline and project emissions when possible. NIRs use the country specific approaches and country specific emission factors that are in line with default IPCC values;
  - b. Lower range of parameters is used for calculation of baseline emissions and higher range of parameters is used for calculation of project activity emissions;
  - c. Default values were used to the extent possible in order to reduce uncertainty and provide conservative data for emission calculations.

**Baseline Emissions**

In order to calculate baseline emissions following assumptions were made:

- 1) The project will produce carbonaceous fraction (0-30mm), which contains energy coal that will displace the same amount of the same type of coal in the baseline scenario;
- 2) The coal that is displaced in the baseline scenario and the coal that is generated in the project activity are used for the same type of purpose and is stationary combusted;
- 3) The coal that is displaced in the baseline scenario is produced by the underground mines of the region and as such causes fugitive emissions of methane;
- 4) The technology of production coal in the mine involves using a large amount of electricity;
- 5) Coal production in mine is accompanied by consumption of other energy sources (gas, diesel, fuel oil), but their share in compare with electricity are small<sup>19</sup>;
- 6) Waste-heaps of the region are vulnerable to spontaneous self-heating and burning and at some point in time will burn;
- 7) Probability of the waste heap burning at any point in time is determined on the basis of the survey of all the waste heaps in the area that provides a ratio of waste heaps that are or have been burning at any point in time to all existing waste heaps;
- 8) Coal burning in the waste heaps will oxidize to CO<sub>2</sub> completely if allowed to burn uncontrolled. Baseline emissions come from two major sources:
  - Carbon dioxide emissions that occur during combustion of energy coal. These are calculated as stationary combustion emissions from mining coal in the equivalent of the amount of coal that is extracted from the waste heaps in the project scenario. These emissions in the baseline scenario is exactly equal to the same emissions in the project scenario, thus are excluded from the calculation;

---

<sup>19</sup> The effective method of electricity consumption control at coal mines. B.A.Gryaduschy, Doctor of Technical. Science, DonUGI, G.N.Lisovoy, V.I.Myalkovsky, Chehlaty NA, Cand. Science, NIIGM named M.M.Fedorov, Donetsk, Ukraine [www.mishor.esco.co.ua/2005/Thesis/10.doc](http://www.mishor.esco.co.ua/2005/Thesis/10.doc)



**Joint Implementation Supervisory Committee**

page 15

- Carbon dioxide emissions from burning waste heaps. These emissions are calculated as emissions of carbon dioxide generated by burning coal dumps, the equivalent amount of coal extracted from the rock dump in the project scenario, adjusted for the probability of burning dumps at any time;

As the baseline suggests that the current situation is preserved regarding the waste heaps burning, it is assumed that for any given waste heap, actual burning will occur in some point in time. This probability of burning is established by the study<sup>20</sup> that assessed the status of all existing waste heaps in Donetsk Region historically. Based on the gathered data it is concluded that 83% of all waste heaps in the Donetsk Region have been, or are now, on fire.

The table below provides values for constant parameters used to determine the baseline emissions

Table 3 - List of constants in the calculation of baseline emissions

<i>Data / Parameter</i>	<i>Data unit</i>	<i>Description</i>	<i>Data Source</i>	<i>Value</i>
$NCV_{Coal}$	TJ/kt	Net Calorific Value of coal	National Inventory Report of Ukraine 1990- 2010 <sup>21</sup> , p. 462, 468 (in the monitoring period the value can be changed)	2009-21.8 2010-21.6 2011-21.6 2012-21.6
$OXID_{Coal}$	d/l	Carbon Oxidation factor of coal	National Inventory Report of Ukraine 1990- 2010, p. 465,471 (in the monitoring period the value can be changed)	2009-0.963 2010-0.962 2011-0.962 2012-0.962
$K_{Coal}^C$	tC/TJ	Carbon content of coal	National Inventory Report of Ukraine 1990- 2010, c. 464,470 (in the monitoring period the value can be changed)	2009-25.97 2010-25.99 2011-25.99 2012-25.99
$p_{WHB}$	d/l	Probability of waste heap burning.	<i>Report on the fire risk of Donetsk Region's waste heaps</i> , Scientific Research Institute "Respirator", Donetsk, 2012.	0.83

Emissions in the baseline scenario are calculated as follows:

$$BE_y = BE_{WHB,y} \quad , \quad (1)$$

where:

$BE_y$  – baseline Emissions in the year y (tCO<sub>2</sub>),

$BE_{WHB,y}$  - baseline Emissions due to burning of the waste heaps in the year y (tCO<sub>2</sub>),

Baseline emissions due to burning dumps in year y calculated by the formula:

$$BE_{WHB,y} = \frac{FC_{BE,Coal,y}}{1000} \cdot p_{WHB} \cdot NCV_{Coal} \cdot OXID_{Coal} \cdot K_{Coal}^C \cdot 44/12 \quad (2)$$

<sup>20</sup> *Report on the fire risk of Donetsk Region's waste heaps*, Scientific Research Institute "Respirator", Donetsk, 2012. This is a proprietary study that will be made available to the accredited independent entity.

<sup>21</sup> [http://unfccc.int/files/national\\_reports/annex\\_i\\_ghg\\_inventories/national\\_inventories\\_submissions/application/zip/ukr-2012-nir-13apr.zip](http://unfccc.int/files/national_reports/annex_i_ghg_inventories/national_inventories_submissions/application/zip/ukr-2012-nir-13apr.zip)



where:

$FC_{BE,Coal,y}$  - amount of coal that has been mined in the baseline scenario and combusted for energy use, equivalent to the amount of coal extracted from the waste heaps because of the project activity in the year  $y$ , t;

$p_{WHB}$  - probability of waste heap burning, d/l;

$NCV_{Coal}$  - net Calorific Value of coal, TJ/kt;

$OXID_{Coal}$  - carbon Oxidation factor of coal, d/l;

$K_{Coal}^c$  - carbon content of coal, tC/TJ;

1/1000 - conversion factor from tons in kilotonnes, d / 1

44/12 - stoichiometric relationship between the molecular weight of carbon dioxide and carbon.

### Leakages

Leakage is the net change of anthropogenic emissions by sources and/or removals by sinks of GHGs which occurs outside the project boundary, and that can be measured and is directly attributable to the JI project.

This project will result in a net change in fugitive methane emissions due to the mining activities. As coal in the baseline scenario is only coming from mines it causes fugitive emissions of methane. These are calculated as standard country specific emission factor applied to the amount of coal that is extracted from the waste heaps in the project scenario (which is the same as the amount of coal that would have been mined in the baseline scenario). Source of the leakage are the fugitive methane emissions due to coal mining. These emissions are specific to the coal that is being mined. Coal produced by the project activity is not mined but extracted from the waste heap through the advanced beneficiation process. Therefore, coal produced by the project activity substitutes the coal would have been otherwise mined in the baseline. Coal that is mined in the baseline has fugitive methane emissions associated with it and the coal produced by the project activity does not have such emissions associated with it.

As reliable and accurate national data on fugitive CH<sub>4</sub> emissions associated with the production of coal are available, project participants used this data to calculate the amount of fugitive CH<sub>4</sub> emission as described below.

This leakage is measurable: through the same procedure as used in 2006 IPCC Guidelines<sup>22</sup> (See Volume 2, Chapter 4, Page 4-11) and also used in CDM approved methodology ACM0009<sup>23</sup> (Page 8). Activity data (in our case amount of coal extracted from the waste heap which is monitored directly) is multiplied by the emission factor (which is sourced from the relevant national study – National Inventory Report of Ukraine under the Kyoto Protocol) and any conversion coefficients.

Electricity consumption and related greenhouse gas emissions due to dismantling of waste heap to be taken into account in calculating the leakages when implementing the project on the basis of calculations beneficiation plant for electricity consumption per tonne of coal received at the processing of rock from dump. Carbon dioxide emissions due to electricity consumption in the coal mine way in an amount, equivalent to the design of coal - a leakage, that can be taken into account at base of the State Statistics Committee data<sup>24</sup>, concerning unit costs of electricity at coal mines in Ukraine in the relevant year.

This leakage is directly attributable to the JI project activity according to the following assumption: the coal produced by the project activity from the waste heap will substitute the coal produced by underground mines of the region in the baseline scenario. This assumption is explained by the following logic: Energy coal market is demand driven as it is not feasible to produce coal without demand for it. Coal is a commodity that can be freely transported to the source of demand and coal of identical quality can substitute some other coal easily. The project activity cannot influence demand for coal on the market and supplies coal extracted from the waste heaps. In the baseline scenario demand for coal will stay the same and will be met by the traditional source – underground mines of the region. Therefore, the coal supplied by the project in the project scenario will have to substitute the coal mined in the baseline scenario. According to this approach equivalent product supplied by the project activity (with lower associated specific green-house gas emissions) will substitute the baseline product (with higher associated specific green-house gas emissions). This methodological approach is very common and is applied in all renewable

<sup>22</sup> [http://www.ipcc-nggip.iges.or.jp/public/2006gl/pdf/2\\_Volume2/V2\\_4\\_Ch4\\_Fugitive\\_Emissions.pdf](http://www.ipcc-nggip.iges.or.jp/public/2006gl/pdf/2_Volume2/V2_4_Ch4_Fugitive_Emissions.pdf)

<sup>23</sup> <http://cdm.unfccc.int/UserManagement/FileStorage/K4P3YG4TNQ5ECFNA8MBK2QSMR6HTEM>

<sup>24</sup> <http://www.ukrstat.gov.ua/>



## Joint Implementation Supervisory Committee

page 17

energy projects (substitution of grid electricity with renewable-source electricity), projects in cement sector (e.g. JI0144 Slag usage and switch from wet to semi-dry process at Volyn-Cement, Ukraine<sup>25</sup>), projects in metallurgy sector (e.g. UA1000181 Implementation of Arc Furnace Steelmaking Plant "Electrostal" at Kurakhovo, Donetsk Region<sup>26</sup>) and others.

These leakages are significant and will be included in the calculation of the project emission reductions. Procedure for ex ante estimate and quantification of this source of leakage is provided below:

Table 4 List of constants used in the calculations of leakage

<i>Data / Parameter</i>	<i>Data unit</i>	<i>Description</i>	<i>Data Source</i>	<i>Value</i>
$GWP_{CH_4}$	tCO <sub>2</sub> /tCH <sub>4</sub>	Global Warming Potential of Methane	IPCC Second Assessment Report <sup>27</sup>	21
$\rho_{CH_4}$	t/m <sup>3</sup>	Methane density	Standard (at room temperature 20°C and 1 ATM) <sup>28</sup>	0.000668
$EF_{CH_4}$	m <sup>3</sup> /t	Emission factor for fugitive methane emissions from coal mining.	National Inventory Report of Ukraine 1990- 2009 <sup>29</sup> , p. 90 (On monitoring stage value can be changed)	25.67
$N_{B,Coal,y}^E$	MWh/t	average electricity consumption per tonne of coal, produced in Ukraine in the year y	Fuel and energy resources of Ukraine, Statistical Yearbook, State Statistics Committee of Ukraine, Kiev 2009-2011 <sup>30</sup> (On monitoring stage value can be changed)	2009 – 0.0905 2010 – 0.0926 2011 – 0.0905 2012 – 0.0905
$EF_{CO_2,EL}$	tCO <sub>2</sub> /MWh	Specific carbon dioxide emissions due to production of electricity at TPP and by its consumption	Order of State Environmental Investments Agency № 63, 43, 75 <a href="http://www.neia.gov.ua/nature/doccatalog/document?id=127171,127172,126006,127498">http://www.neia.gov.ua/nature/doccatalog/document?id=127171, 127172, 126006, 127498</a> (On monitoring stage value can be changed)	2009 – 1.237 2010 – 1.225 2011 – 1.227 2012 – 1.227

25

[http://ji.unfccc.int/JI\\_Projects/DB/P1QYRYMBQCEQOT0HOQM60MBQ0HXNYU/Determination/Bureau%20Veritas%20Certification1266348915.6/viewDeterminationReport.html](http://ji.unfccc.int/JI_Projects/DB/P1QYRYMBQCEQOT0HOQM60MBQ0HXNYU/Determination/Bureau%20Veritas%20Certification1266348915.6/viewDeterminationReport.html)

<sup>26</sup> <http://ji.unfccc.int/JIITLProject/DB/4THB9WT0PK6F721UQA5H6PTHZEXT4C/details>

<sup>27</sup> IPCC Second Assessment: Climate Change 1995. A Report of the Intergovernmental Panel on Climate Change". Bolin, B. et al. (1995). IPCC website. <http://www.ipcc.ch/pdf/climate-changes-1995/ipcc-2nd-assessment/2nd-assessment-en.pdf>

<sup>28</sup> [http://www.engineeringtoolbox.com/gas-density-d\\_158.html](http://www.engineeringtoolbox.com/gas-density-d_158.html)

<sup>29</sup> [http://unfccc.int/files/national\\_reports/annex\\_i\\_ghg\\_inventories/national\\_inventories\\_submissions/application/zip/ukr-2011-nir-08jun.zip](http://unfccc.int/files/national_reports/annex_i_ghg_inventories/national_inventories_submissions/application/zip/ukr-2011-nir-08jun.zip)

<sup>30</sup> <http://www.ukrstat.gov.ua/>

This template shall not be altered. It shall be completed without modifying/adding headings or logo, format or font.





Joint Implementation Supervisory Committee  
Baseline leakages in year y calculated as follows:

page 18

$$LE_y = LE_{CH_4,y} + LE_{B,EL,y} \quad (3)$$

where:

$LE_y$  - leakages in year y, (τ CO<sub>2</sub>e);

$LE_{CH_4,y}$  - leakages due to fugitive emissions of methane in the mining activities in the year y, (τ CO<sub>2</sub>e);

$LE_{B,EL,y}$  - leakages due to consumption of electricity in the mining activities in the year y, (τ CO<sub>2</sub>e).

Leakages due to fugitive emissions of methane in the mining activities in the year y calculated as follows:

$$LE_{CH_4,y} = -FC_{BE,Coal,y} \cdot EF_{CH_4} \cdot \rho_{CH_4} \cdot GWP_{CH_4} \quad (4)$$

Where:

$FC_{BE,Coal,y}$  - amount of coal that has been mined in the baseline scenario and combusted for energy use, equivalent to the amount of coal extracted from the waste heaps because of the project activity in the year y, t;

$EF_{CH_4}$  - emission factor for fugitive methane emissions from coal mining, m<sup>3</sup>/t;

$\rho_{CH_4}$  - methane density (standard, at room temperature 20 ° C and 1 atm), t/m<sup>3</sup>;

$GWP_{CH_4}$  - global warming potential for methane, τCO<sub>2</sub>/τCH<sub>4</sub>.

Leakages due to consumption of electricity in the mining activities in the year y calculated as follows:

$$LE_{B,EL,y} = -FC_{BE,Coal,y} \cdot N_{B,Coal,y}^E \cdot EF_{CO_2,EL} \quad (5)$$

Where:

$FC_{BE,Coal,y}$  - amount of coal that has been mined in the baseline scenario and combusted for energy use, equivalent to the amount of coal extracted from the waste heaps because of the project activity in the year y, t;

$N_{B,Coal,y}^E$  - average electricity consumption per tonne of coal, produced in Ukraine in the year y, MW-h/t

$EF_{CO_2,EL}$  - Specific carbon dioxide emissions due to production of electricity at TPP and by its consumption, tCO<sub>2</sub>/MW-h

Baseline emissions due to consumption of other types of energy in coal mines are insignificant compared to the emissions due to electricity consumption<sup>31</sup>, so in connection with this, and for reasons of conservatism, take them equal to zero.

Key information and data used to establish the baseline are provided below in tabular form:

Table 5 - Amount of coal that has been mined in baseline scenario

Data/Parameter	$FC_{BE,Coal,y}$
Data unit	t
Description	Amount of coal that has been mined in the baseline scenario and combusted for energy use, equivalent to the amount of coal extracted from the waste heaps because of the project activity in year y
Time of <u>determination/monitoring</u>	Yearly monitoring.
Source of data (to be) used	Project owner calculations
Value of data applied (for ex ante calculations/determinations)	Provided by project owner
Justification of the choice of data or description of measurement methods and procedures (to be) applied	Measured for the commercial purposes on site
QA/QC procedures (to be) applied	According to the project owner policy.
Any comment	No

<sup>31</sup> The effective method of electricity consumption control at coal mines. B.A.Gryaduschy, Doctor of Technical Science, DonUGI, G.N.Lisovoy, V.I.Myalkovsky, Chehlaty NA, Cand. Science, NIIGM named M.M.Fedorov, Donetsk, Ukraine [www.mishor.esco.co.ua/2005/Thesis/10.doc](http://www.mishor.esco.co.ua/2005/Thesis/10.doc)



Table 6 - Net Calorific Value of coal

<b>Data/Parameter</b>	<i>NCV<sub>Coal</sub></i>
Data unit	TJ/kt
Description	Net Calorific Value of coal
Time of determination/ <u>monitoring</u>	Fixed ex ante.
Source of data (to be) used	National Inventory Report of Ukraine 1990- 2010., p. 462,468 (in the monitoring period the value can be changed)
Value of data applied (for ex ante calculations/determinations)	2009-21.8 2010-21.6 2011-21.6 2012-21.6
Justification of the choice of data or description of measurement methods and procedures (to be) applied	The default value is set according to the National Inventory.
QA/QC procedures (to be) applied	According to the National Inventory.
Any comment	No

Table 7 - Carbon Oxidation factor of coal

<b>Data/Parameter</b>	<i>OXID<sub>Coal</sub></i>
Data unit	d/l
Description	Carbon Oxidation factor of coal
Time of determination/monitoring	Fixed ex ante.
Source of data (to be) used	National Inventory Report of Ukraine 1990- 2010., p. . 465, 471 (in the monitoring period the value can be changed)
Value of data applied (for ex ante calculations/determinations)	2009-0.963 2010-0.962 2011-0.962 2012-0.962
Justification of the choice of data or description of measurement methods and procedures (to be) applied	The default value is set according to the National Inventory.
QA/QC procedures (to be) applied	According to the National Inventory.
Any comment	No



Table 8 - Carbon content of coal

<b>Data/Parameter</b>	$K_{coal}^c$
Data unit	tC/TJ
Description	Carbon content of coal
Time of determination/monitoring	Fixed ex ante.
Source of data (to be) used	National Inventory Report of Ukraine 1990- 2010., p. 464, 470 (in the monitoring period the value can be changed)
Value of data applied (for ex ante calculations/determinations)	2009-25.97 2010-25.99 2011-25.99 2012-25.99
Justification of the choice of data or description of measurement methods and procedures (to be) applied	The default value is set according to the National Inventory.
QA/QC procedures (to be) applied	According to the National Inventory.
Any comment	No

Table 9 - Probability of waste heap burning.

<b>Data/Parameter</b>	$p_{WHB}$
Data unit	d/l
Description	Probability of waste heap burning.
Time of determination/monitoring	Fixed ex ante.
Source of data (to be) used	<i>Report on the fire risk of Donetsk Region's waste heaps</i> , Scientific Research Institute "Respirator", Donetsk, 2012.
Value of data applied (for ex ante calculations/determinations)	0.83
Justification of the choice of data or description of measurement methods and procedures (to be) applied	The default value is set according to the Scientific Research Institute "Respirator"
QA/QC procedures (to be) applied	According to the Scientific Research Institute "Respirator"
Any comment	No

**B.2. Description of how the anthropogenic emissions of greenhouse gases by sources are reduced below those that would have occurred in the absence of the JI project:**

The following step-wise approach is used to demonstrate that the project provides reductions in emissions by sources that are additional to any that would otherwise occur:

**Step 1. Indication and description of the approach applied**

As suggested by Paragraph 2 (b) of the Annex 1 of JISC " Guidance on Criteria for Baseline Setting and Monitoring " version 03, the approach to demonstrate additionality will consist of provision of traceable and transparent information that an accredited independent entity has already positively determined that a comparable project (to be) implemented under comparable circumstances (same GHG mitigation measure, same country, similar technology, similar scale) would result in a reduction of anthropogenic emissions by sources or an enhancement of net anthropogenic removals by sinks that is additional to any that would otherwise occur and a justification why this determination is relevant for the project at hand.

**Step 2. Application of the approach chosen**

The following steps are taken in order to demonstrate additionality of this project:

***Step 1: Identify comparable project where an accredited independent entity has already positively determined that it would result in a reduction of anthropogenic emissions by sources or an enhancement of net anthropogenic removals by sinks that is additional to any that would otherwise occur.***

The project "Waste heaps dismantling with the aim of decreasing the greenhouse gases emissions into the atmosphere" is selected as the comparable JI project. Accredited independent entity has already positively determined that it would result in a reduction of anthropogenic emissions by sources or an enhancement of net anthropogenic removals by sinks that is additional to any that would otherwise occur. This determination has already been deemed final by the JISC. Appropriate documentation such as PDD and Determination Report regarding this project is available traceably and transparently on the UNFCCC JI Website<sup>32</sup>

***Step 2: Demonstrate that the identified project is a comparable project (to be) implemented under comparable circumstances:***

- 1) Both projects propose **same GHG mitigation measure:** The proposed GHG mitigation measure under both projects is coal extraction from the mine's waste heaps. This will prevent greenhouse gas emissions into the atmosphere during combustion of the heaps and will contribute an additional amount of coal, without the need for mining.
- 2) Both projects are implemented within the **same country:** The proposed project and identified comparable project are both located in Ukraine.
- 3) Both projects utilize **similar technology:** The technology utilized by the proposed project and identified comparable project is similar. In both projects the waste heap is dismantled using standard excavators and bulldozers. Trucks are used to move the waste heap matter to the processing facility. The processing facility in both projects is the coal washing plant that utilizes several technologies to separate coal from the rest of the matter. Both technologies use gravity separation method. Gravity separation is an industrial method of separating two components from a suspension or any other homogeneous mixture where separating the components with gravity is sufficiently practical. So both technologies are similar.
- 4) Both projects have **similar scale:** Both projects are large scale JI projects. Both projects process waste heaps of comparable scale. The proposed project consists of one site that will operate during a certain period of time while the comparable project consists of two sites that will have a very limited period of simultaneous operation. Nominal capacity of the processing plant in comparable project consists 100000 tonnes of material per month or 1200000 tones per year. Equipment in the comparable project does not

<sup>32</sup>

[http://ji.unfccc.int/JI\\_Projects/DB/VOZK3HERSNQGFCLCY0YZ3AX5W676M5R/Determination/Bureau%20Veritas%20Certification1277814730.41/viewDeterminationReport.html](http://ji.unfccc.int/JI_Projects/DB/VOZK3HERSNQGFCLCY0YZ3AX5W676M5R/Determination/Bureau%20Veritas%20Certification1277814730.41/viewDeterminationReport.html)

**Joint Implementation Supervisory Committee**

page 22

work at full capacity, so the resulting coal (60,000 tons per year) is less than in the proposed project (approximately 200,000 tonnes per year), but these figures the same order. The scale of coal extraction is limited by the coal content of the waste heap matter and the size of the waste heaps. Therefore the criteria identified by the Guidance are satisfied and the identified project is indeed a comparable project implemented under comparable circumstances

**Step 3: Provide justification why determination for a comparable project is relevant for the project at hand.**

The project “Waste heaps dismantling with the aim of decreasing the greenhouse gases emissions into the atmosphere” and the proposed project are both implemented within the same geographic region of Ukraine – the Donbas coal mining region. The implementation timeline is quite similar: Kyoto period (2008-2012) is a period where a most extensive work in both projects is carried out.

Both projects will share the same investment profile and market environment. These two projects are implemented by private companies with no utilization of public funds. The investment climate will be comparable in both cases with the coal sector being an almost non-profitable sector in Ukraine<sup>33</sup> burdened by many problems. The market for the extracted coal will also be similar for both projects as these are small private companies that will not be able to sell coal in big quantities under long-term contracts. Ukrainian coal sector is largely state-controlled. Energy and Coal Ministry of Ukraine decides production level of state mines, based on their performance. After this, state controlled mines sell their coal to the state Trading Company "Coal of Ukraine". This company also buys coal from private mines and arranges supply of coal to thermal electricity companies. Prices for coal mines differ significantly for public and private mines. In general, prices of state mines are more than 60% higher than the prices for private enterprises<sup>34</sup>. Both projects also share the investment climate of Ukraine which is far from being favourable. Ukraine is considered to be a high risk country for doing business and investing in. Almost no private capital is available from domestic or international capital markets for mid to long term investments, and any capital that is available has high cost. The table below represents risks of doing business in Ukraine according to various international indexes and studies.

Table 10 - International ratings of Ukraine<sup>35</sup>

<b>Organization, which provides rating</b>	<b>Name of rating</b>	<b>Ukraine's place in the rating</b>	<b>Number of countries in the rating</b>
Fung Heritage (2010)	Economic Freedom Rating	162	179
Pro UN (2009)	The Human Development Index	85	182
Transparency International (2009)	Index of corruption	146	180
Freedom House (2009)	freedom of Speech	115	195
World Bank, The International Finance Corporation and the Audit Company Price Waterhouse Coopers (2010)	Rating of ease of paying taxes	181	183
World Economic Forum (Davos) (2009-2010)	Rating of global competitiveness	82	133
World Economic Forum (Davos) (2009)	Financial strength rating	55	55
“Alliance for Property Rights” (USA)	Rating of property rights protection	58	70

<sup>33</sup> [http://www.necu.org.ua/wp-content/plugins/wp-download\\_monitor/download.php?id=126](http://www.necu.org.ua/wp-content/plugins/wp-download_monitor/download.php?id=126)

<sup>34</sup> [http://www.ier.com.ua/files/publications/Policy\\_papers/German\\_advisory\\_group/2009/PP\\_09\\_2009\\_ukr.pdf](http://www.ier.com.ua/files/publications/Policy_papers/German_advisory_group/2009/PP_09_2009_ukr.pdf)

<sup>35</sup> [http://sd.net.ua/2010/06/11/ukraine\\_ratings.html](http://sd.net.ua/2010/06/11/ukraine_ratings.html)



**Joint Implementation Supervisory Committee**

The data above shows that both real and perceived risks of investing in Ukraine are in place and influence the availability of capital in Ukraine both in terms of size of the investments and in terms of capital costs. The comparison of commercial lending rates in Ukraine and in Eurozone for the loans over 5 years in EUR is presented in a figure below:

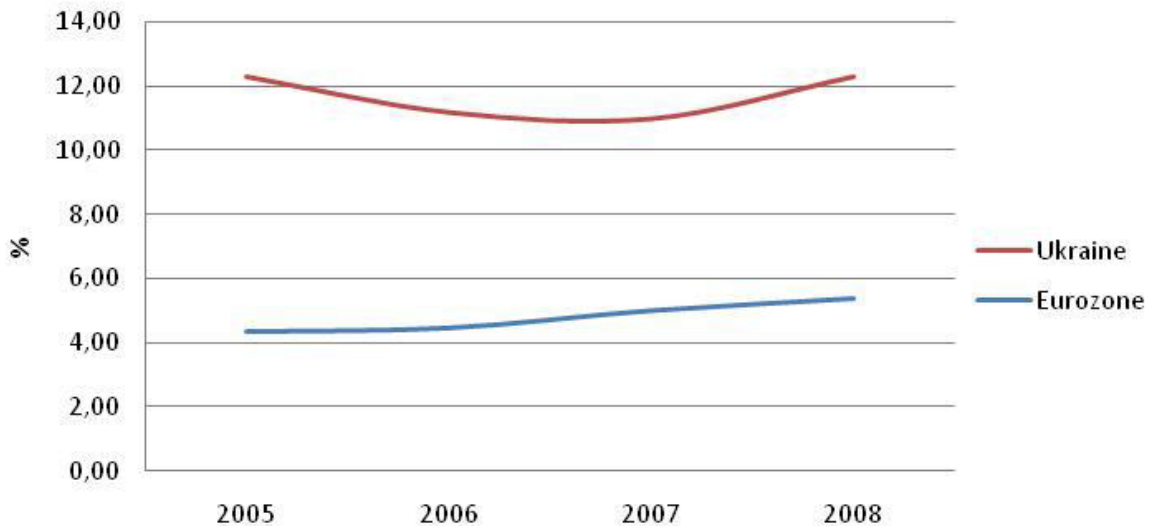

Figure 8 - Commercial lending rates, EUR, over 4 years<sup>36</sup>

Cost of debt financing in Ukraine is at least twice as high than in the Eurozone. The risks of investing into Ukraine are additionally confirmed by the country ratings provided by the Moody’s international rating agency and the associated country risk premium. The table below compares country risk premiums for Russia and Ukraine<sup>37</sup>:

Table 11 - Sovereign Awards for Russia and Ukraine in 2004-2006

Total Risk Premium, %	2004	2005	2006
Russia	7.02	6.6	6.64
Ukraine	11.59	10.8	10.16

As stated at the OECD Roundtable on Enterprise Development and Investment Climate in Ukraine, the current legal basis is not only inadequate, but to a large extent it sabotages the development of market economy in Ukraine. Voices in the western press can basically be summarized as follows: The reforms in the tax and legal systems have improved considerably with the adoption of the commercial Code, Civil Code and Customs Code on 1 January 2004 but still contain unsatisfactory elements and pose a risk for foreign investors<sup>38</sup>. Ukraine is considered to be heading in the right direction with significant reforms having been put into action but still has a long way to go to realize its full potential. Frequent and unpredictable changes in the legal system along with conflicting and inconsistent Civil and Commercial Codes do not allow for a transparent and stable enforced legal business environment. This is perceived as a great source of uncertainty by international companies, which make future predictions of business goals and strategy risky.

<sup>36</sup> Data for Ukraine from National Bank of Ukraine

[http://www.bank.gov.ua/Statist/Electronic%20bulletin/data/4-Financial%20markets\(4.1\).xls](http://www.bank.gov.ua/Statist/Electronic%20bulletin/data/4-Financial%20markets(4.1).xls)

<sup>37</sup> Data from Aswath Damodaran, Ph.D., Stern School of Business NYU <http://pages.stern.nyu.edu/~adamodar/>

<sup>38</sup> Foreign Direct Investment in Ukraine – Donbass, Philip Burris, Problems of foreign economic relations development and attraction of foreign investments: regional aspect., ISSN 1991-3524, Donetsk, 2007. p. 507-510



The conclusion from the abovementioned is as follows: the investment climate of Ukraine is risky and unwelcoming, private capital is not available from domestic or international sources or available at prohibitively high cost due to real and perceived risks of doing business in Ukraine as shown by various sources. Alternatives markets, such as Russia, offer similar profile of investment opportunities with lower risk and better business environment.

Taking into account the information provided above it is possible to conclude that the determination of the project "Waste heaps dismantling with the aim of decreasing the greenhouse gases emissions into the atmosphere" is relevant for the project at hand.

**Outcome of the analysis:** We have provided traceable and transparent information that an accredited independent entity has already positively determined that a comparable project "Waste heaps dismantling with the aim of decreasing the greenhouse gases emissions into the atmosphere" (Registration Project ID: 0214) implemented under comparable circumstances (same GHG mitigation measure, same country, similar technology, similar scale) would result in a reduction of anthropogenic emissions by sources or an enhancement of net anthropogenic removals by sinks that is additional to any that would otherwise occur and have provided justification on why this determination is relevant for the project at hand. Therefore, this project is additional.

### **B.3. Description of how the definition of the project boundary is applied to the project:**

Project implementation will take place only on dump, which officially is in use of LLC "Trading House "Metalprom". At the same time, according to baseline, the notional typical mine, which produces coal, replaced by the coal from dismantling of heap, takes part in fugitive emissions. The specific of energy consumption at coal mines is determined by the following main components: power consumption, heat consumption, air consumption, consumption of natural gas and other types of fuel and water, sewage discharges, sewage treatment. As a result of the work<sup>39</sup> is found, that about 90% of the total consumption of energy in coal mines is electricity.

There are several sources of greenhouse gases due to mining:

- Uncontrolled methane emissions as a result of working the coal industry in Ukraine;
- Carbon dioxide emissions due to electricity consumption at the mine;
- Emissions of carbon dioxide due to burning of the new dumps formed due to mining;
- Carbon dioxide emissions due to consumption of other types of fuel at the mine (given the small number and for reasons of conservatism is not considered);

Carbon dioxide emissions due to consumption of electricity produced by burning fossil fuels in power plants of Ukraine and uncontrolled methane emissions as a result of mining activity, are leakages .

The table 10 shows an overview of all sources of emissions in the baseline and project scenarios. The project boundaries depicted in accordance with the provisions of Articles 14, 16, 17 Guidelines Supervisory Committee.

---

<sup>39</sup> The effective method of electricity consumption control at coal mines. B.A.Gryaduschy, Doctor of Technical. Science, DonUGI, G.N.Lisovoy, V.I.Myalkovsky, Chehlaty NA, Cand. Science, NIIGM named M.M.Fedorov, Donetsk, Ukraine [www.mishor.esco.co.ua/2005/Thesis/10.doc](http://www.mishor.esco.co.ua/2005/Thesis/10.doc)

Table 12 - Sources of emissions in the baseline and project scenario.

Baseline scenario	Source	Gas	Included/ Excluded	Justification / Explanation
	Waste heap burning	CO <sub>2</sub>	Included	Main emission source
	Coal consumption	CO <sub>2</sub>	Excluded	This coal is displaced in the project activity by the coal extracted from the waste heaps.
Project scenario	Coal consumption	CO <sub>2</sub>	Excluded	The coal is extracted from waste heap.
	Consumption of fossil fuel due to extracting coal from dump	CO <sub>2</sub>	Included	Main emission source.
Leakages	Emissions of methane as a result of the coal industry	CH <sub>4</sub>	Included	These leaks are taking place in the baseline scenario associated with the uncontrolled leakage of methane in the mine
	Consumption of electricity due to mining	CO <sub>2</sub>	Included	Leakages due to baseline activity
	Use of other types of energy resources due to mining	CO <sub>2</sub>	Excluded	These emissions are not significant <sup>40</sup> , and also for reasons of conservatism, they are excluded from consideration.
	Consumption of electricity due to beneficiation of coal from dump	CO <sub>2</sub>	Included	Leakages due to project activity

### The baseline scenario

The basic scenario is the continuation of the current situation. Coal is mined in underground mines, which causes uncontrolled methane emissions. When coal is consumed electricity and other fuels. Coal is used for energy production. In the process of coal formed a new blade. Dumps heat and often light up, resulting in emissions of carbon dioxide in the atmosphere. The sources of emissions in the baseline scenario are:

- Emissions of carbon dioxide due to consumption of coal for energy production (identical in baseline and project scenario);
- Emissions of carbon dioxide due to burning of coal dump;

### Project scenario

By the project scenario dumps are dismantled, and all combustible materials are removed. Thus, emissions due to ignition and burning dumps are reduced. Project implementation includes additional burning diesel fuel due to supply the rock from dumps to the sorting point of coal. For operation of the equipment the electricity is used. Additional amount of coal obtained from the project, reduced the need for its production in the mines. The sources of emissions in the project scenario are:

- Emissions of carbon dioxide from the use of fuel for the operation of the project equipment (technics);
- Emissions of carbon dioxide from the consumption of coal for energy production (identical in baseline and project scenario).

---

<sup>40</sup> The effective method of electricity consumption control at coal mines. B.A.Gryaduschy, Doctor of Technical. Science, DonUGI, G.N.Lisovoy, V.I.Myalkovsky, Chehlaty NA, Cand. Science, NIIGM named M.M.Fedorov, Donetsk, Ukraine [www.mishor.esco.co.ua/2005/Thesis/10.doc](http://www.mishor.esco.co.ua/2005/Thesis/10.doc)

The sources of leakages are:

- Uncontrolled methane emissions due to coal mining in the mines;
- Emissions of carbon dioxide due to consumption of electricity and other forms of energy in coal mining in the mine.
- Emissions of carbon dioxide associated with electricity consumption at beneficiation plant for receiving the coal concentrate from rock material of dump.

The following figures show the project boundaries and sources of emissions in the baseline and project scenarios:

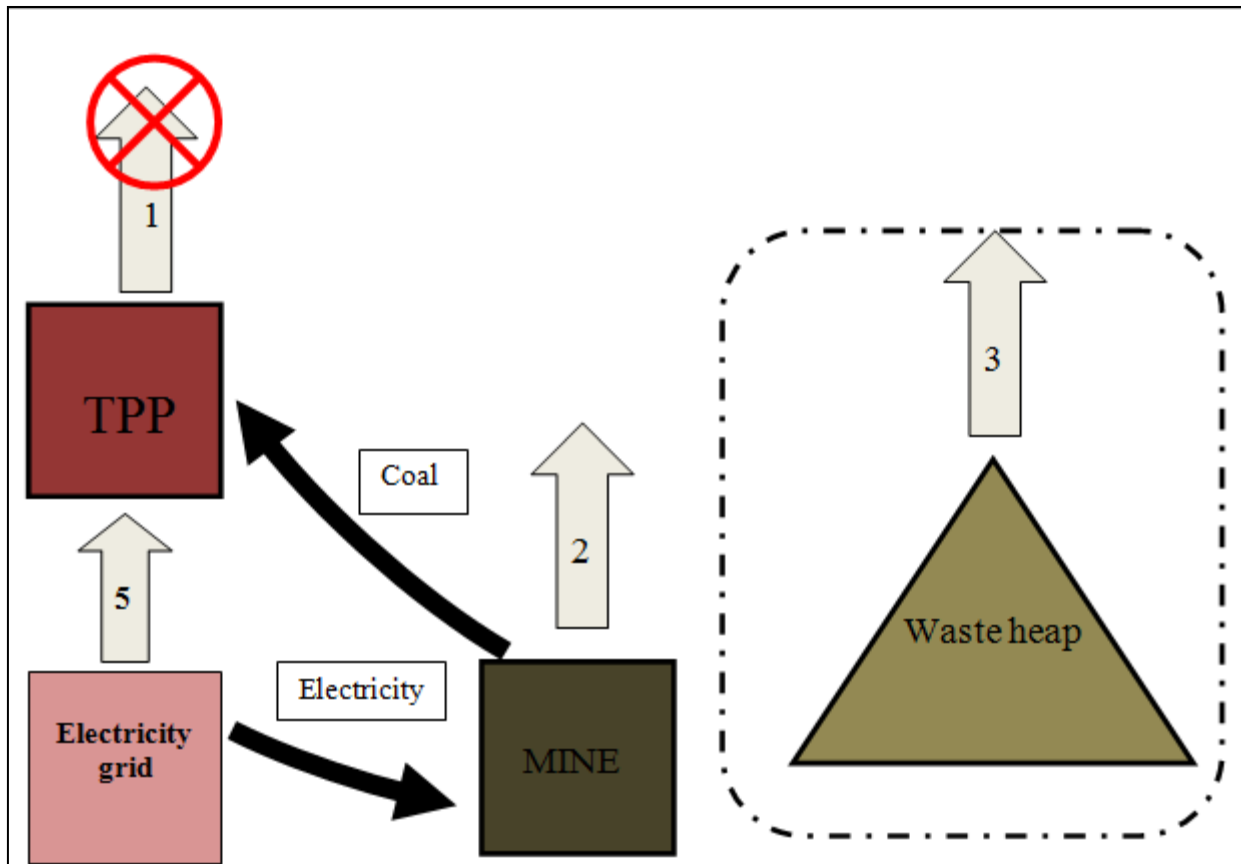

Figure 9 - The boundaries of the project and the sources of emissions in the baseline scenario

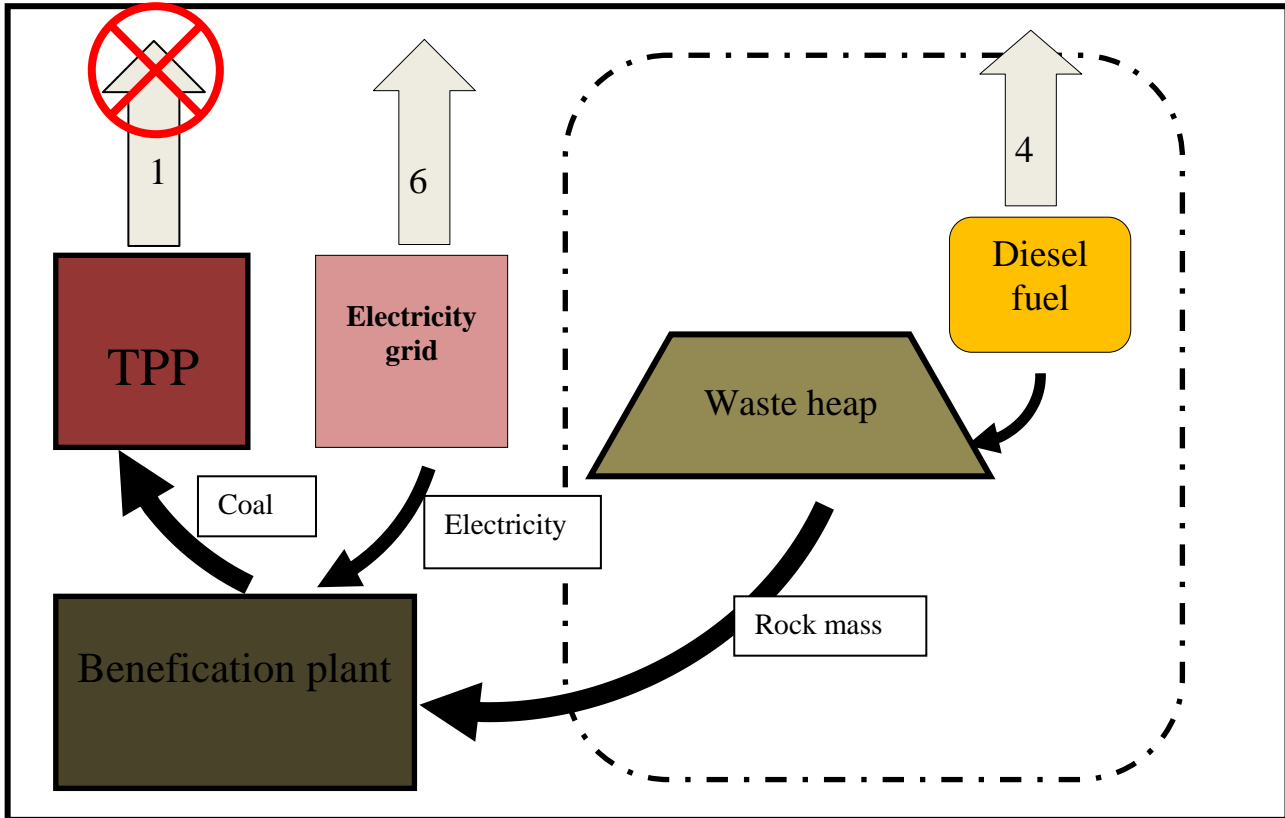
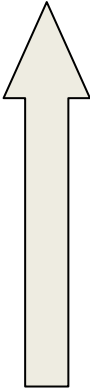



Figure 10 - The boundaries of the project and the source of emissions in the project scenario

#### Sources of greenhouse gas emissions at schemes

- 
1. Carbon dioxide due to burning of coal
  2. Leakages of methane due to mining
  3. Carbon dioxide due to burning of waste heap
  4. Carbon dioxide due to consumption of diesel fuel during dismantling the dump
  5. Carbon dioxide due to consumption of electricity in mine
  6. Carbon dioxide due to consumption of electricity during beneficiation of rock mass from the dump
- 
- Emissions due to burning of coal excluded from consideration

#### B.4. Further baseline information, including the date of baseline setting and the name(s) of the person(s)/entity(ies) setting the baseline:

Date of determination the baseline scenario: 23/03/2012

Name of person / organization, determining the baseline scenario:

Gennadiy Ivanenko, Project manager at SIA "Vidzeme Eko", tel: +38044 222 61 63, fax: +38044 222 61 63, e-mail: info@ekoji.lv

"Vidzeme Eko" – project participant, contact details are available in Annex 1.



**SECTION C. Duration of the project / crediting period****C.1. Starting date of the project:**

The date of commencement of the project is 23-th of October, 2009. From this date the dismantling of waste heap begins.

**C.2. Expected operational lifetime of the project:**

The life cycle of the project will last from 23/10/2009 to 31/12/2012.

**C.3. Length of the crediting period:**

Length of crediting period - from 23/10/2009 to 31/12/2012.

**SECTION D. Monitoring plan****D.1. Description of monitoring plan chosen:**

In order to provide a detailed description of the monitoring plan chosen, a step-wise approach is used:

***Step 1. Indication and description of the approach chosen for realizing of monitoring.***

Option *a* provided by the Guidelines For The Users Of The Joint Implementation Project Design Document Form, Version 04<sup>41</sup> is used: JI specific approach is used in this project and therefore will be used for establishment of monitoring plan.

Among other things, the monitoring plan includes the following:

- Collecting and archiving all relevant data needed for evaluation and measurement of anthropogenic emissions by sources of emissions that occur within the project during the crediting period;
- Collecting and archiving all relevant data necessary for determining the baseline of anthropogenic emissions by sources of GHGs within the project during the crediting period;
- Identify all potential sources and collect and archive data regarding the enhancement the level of anthropogenic emissions by sources of emissions outside the project, which is significant and which can be attributed to the project during the crediting period.
- Procedures to ensure quality control and process monitoring;
- Procedures for periodic calculation reductions of anthropogenic emissions from sources in the proposed JI project, and procedures for calculating the effects of leakage, if any.

***Step 2. Application of the approach chosen.***

All data collected during monitoring should be archived and stored for at least 2 years after the last application for ERU.

These should be checked, unless otherwise indicated in the following sections. All measurements must be executed with calibrated measurement equipment according to industry standards for the branch.

***Baseline scenario***

The baseline scenario is the continuation of the current situation. Coal is mined in underground mines, which causes uncontrolled methane emissions. Due to mining the electricity and other types of fuel are consumed. Coal is used for energy production. A new dump formed In the process of coal mining. Dumps are heated and often are ignited, resulting in emissions of carbon dioxide in the atmosphere. The sources of emissions in the baseline

---

<sup>41</sup> <http://ji.unfccc.int/Ref/Documents/Guidelines.pdf>



scenario are:

- Emissions of carbon dioxide due to consumption of coal for energy production;
- Emissions of carbon dioxide due to burning of coal dump;

The sources of leakages are:

- Uncontrolled methane emissions due to coal mining in the mines;
- Emissions of carbon dioxide due to consumption of electricity and other forms of energy in coal mining in the mine.

### ***Project scenario***

In the project scenario dumps are dismantled, and all combustible materials are removed. Thus, emissions due to ignition and burning dumps are reduced. Project implementation includes additional burning diesel fuel to supply the mining of rock dumps to the point of beneficiation of coal. The electricity is used for operation of the equipment of beneficiation plant. Additional coal obtained from the project, reducing the need for its production in the mines. The sources of emissions in the project scenario are:

- Emissions of carbon dioxide due to consumption of fuel for the operation of the project equipment (mining machinery);
- Emissions of carbon dioxide due to consumption of electricity by project equipment;
- Emissions of carbon dioxide from the use of coal mined from rock dump for energy production (equal to emissions from burning an equivalent amount of coal produced in mines in the baseline scenario, so they are excluded from the calculation in both scenarios).

The sources of emissions in the project scenario are:

- Emissions of carbon dioxide due to consumption of electricity by the equipment of beneficiation plant;

During any period of monitoring must be collected and recorded data on the following parameters:

#### **1. Amount of diesel fuel consumed in the appropriate period as a result of a project activity.**

To determine this parameter the commercial data of company are used. To confirm the consumed amount of fuel checks and other accounting documents are used. The fuel consumption, which is related to a project activity, is taken into account. Information summary report is based on accounts. In the industrial site there is not any additional equipment, but if such equipment is used, fuel consumption of this equipment is also considered. If the data in these documents are in litres instead of tonnes, these data must be converted using factor of 0.85 kg / l<sup>42</sup>. For purpose of control a theoretical calculation of diesel fuel consumption is made on basis of technical specifications and actual record of machinery work.

#### **2. Amount of coal, which is in the appropriate period was extracted from the dump and combusted for obtaining the energy, used for activities under the project, equal to the amount of coal that was in the baseline scenario produced from the mine and combusted for obtaining the energy.**

---

<sup>42</sup> <http://elarus.ru/info/standards/gost-305-82/>



To determine this parameter the commercial data of company are used. To confirm the amount of coal checks and documents from customers are used. Taken into account and refers to the project activity only product which delivered to the customer. Weighing takes place on site using certified scales. Regular cross-inspections with customers are executed. Information of summarized reports is based on these delivery data.

### **Measuring devices**

The method of measurement, chosen for this project, is based on the measurement of some parameters to be monitored - extracted coal, and the study of accounting documents and reports on other parameters (used fuel). For measuring procedures in the project the following equipment is used:

- electronic truck gage scales BTA-60, produced by JV "Ukrestmarkinvest" accuracy "Medium" (III) (measurement error with standard truck load of + / - 0.25%)  
frequency of testing 12 months;

### **Archiving, data storage and record handling procedure**

Documents and reports on the data that are monitored will be archived and stored by the project participants. The following documents will be stored: primary documents for the accounting of monitored parameters in paper form; intermediate reports, orders and other monitoring documents in paper and electronic form; documents on measurement devices in paper and electronic form. These documents and other data monitored and required for determination and verification, as well as any other data that are relevant to the operation of the project will be kept for at least two years after the last transfer of ERUs.

### **Training of monitoring personnel**

The project will utilize technology that requires skills and knowledge in heavy machinery operation, coal washing technology operation, electric equipment operation etc. This kind of skills and knowledge is available locally through the system of vocational training and education. This system is state-supervised in Ukraine. Professionals who graduate from vocational schools receive a standard certificate in the field of their professional study. Only workers with proper training can be allowed to operate industrial equipment like. Management of the project host will ensure that personnel of the project have received proper training and are eligible to work with the prescribed equipment.

Training on safety issues is mandatory and must be provided to all personnel of the project as required by local regulations. Procedure for safety trainings includes the scope of the trainings, training intervals, forms of training, knowledge checks etc. The project host management will maintain records for such trainings and periodic knowledge check-ups.

Activities that are directly related to the monitoring do not require specific training other than provided by the professional education. However, monitoring personnel will receive training on monitoring procedures and requirements. Personnel of the project host management will receive necessary training and consultations on Kyoto Protocol, JI projects and monitoring from the project participant - SIA "Vidzeme Eko".

### **Procedures identified for corrective actions in order to provide for more accurate future monitoring and reporting**

In cases if any errors, fraud or inconsistencies will be identified during the monitoring process special commission will appointed by project host management that will conduct a review of such case and issue an order that must also include provisions for necessary corrective actions to be implemented that will ensure such situations are avoided in future.



The project host management will also establish a communication channel that will make it possible to submit suggestions, improvement proposals and project ideas for more accurate future monitoring for every person involved in the monitoring activities. These actions occur through close cooperation with SIA "Vidzeme Eko", external consultant LLC "Trading House "Metalprom" on JI projects.

#### Emergency preparedness for cases where emergencies can cause unintended emissions

The project operation does not foresee any factors or emergencies that can cause unintended GHG emissions. Safe operation of equipment and personnel is ensured by systematic safety training. Procedures for dealing with general emergencies such as fire, major malfunction etc., are developed as part of the mandatory business regulations and are in accordance with local requirements.

Table 13 - List of constants used in the calculations of emissions

<i>Data / Parameter</i>	<i>Data unit</i>	<i>Description</i>	<i>Data Source</i>	<i>Value</i>
$GWP_{CH_4}$	tCO <sub>2</sub> / tCH <sub>4</sub>	Global Warming Potential of Methane	IPCC Second Assessment Report	21
$\rho_{CH_4}$	t/m <sup>3</sup>	Methane density	Standard (at room temperature 20°C and 1 ATM)	0,000668
$NCV_{Coal}$	TJ/kt	Net Calorific Value of coal	National Inventory Report of Ukraine 1990- 2010., p. 462, 471	2009-21.8 2010-21.6 2011-21.6 2012-21.6
$NCV_{Diesel}$	TJ/kt	Net Calorific Value of diesel fuel	National Inventory Report of Ukraine 1990- 2010., p. 476, 479	2009-42.3 2010-42.5 2011-42.5 2012-42.5
$OXID_{Coal}$	d/l	Carbon Oxidation factor of coal	National Inventory Report of Ukraine 1990- 2010, p. 465, 471	2009-0.963 2010-0.962 2011-0.962 2012-0.962
$OXID_{Diesel}$	d/l	Carbon Oxidation factor of diesel fuel	National Inventory Report of Ukraine 1990- 2010, p. 478,481	2009-0.99 2010-0.99 2011-0.99 2012-0.99





$K_{coal}^c$	tC/TJ	Carbon content of coal	National Inventory Report of Ukraine 1990- 2010, p. 464,470	2009-25.97 2010-25.99 2011-25.99 2012-25.99
$K_{Diesel}^c$	tC/TJ	Carbon content of diesel fuel	National Inventory Report of Ukraine 1990- 2010, p. 477, 480	2009-20.2 2010-20.2 2011-20.2 2012-20.2
$EF_{CH_4}$	m <sup>3</sup> /t	Emission factor for fugitive methane emissions from coal mining.	National Inventory Report of Ukraine 1990- 2009, p. 90	25.67
$EF_{CO_2,EL}$	tCO <sub>2</sub> /MWh	Specific carbon dioxide emissions due to production of electricity at TPP and by its consumption	Order of State Environmental Investments Agency № 63, 43, 75 <a href="http://www.neia.gov.ua/nature/doccatalog/document?id=127171,127172,126006,127498">http://www.neia.gov.ua/nature/doccatalog/document?id=127171, 127172, 126006, 127498</a>	2009 – 1.237 2010 – 1.225 2011 – 1.227 2012 – 1.227
$p_{WHB}$	d/l	Probability of waste heap burning.	<i>Report on the fire risk of Donetsk Region's waste heaps</i> , Scientific Research Institute "Respirator", Donetsk, 2012.	0.83
$N_{B,Coal,y}^E$	MWh/t	average electricity consumption per tonne of coal, produced in Ukraine in the year y	Fuel and energy resources of Ukraine, Statistical Yearbook, State Statistics Committee of Ukraine, Kiev, 2009-2011.	2009 – 0.0905 2010 – 0.0926 2011 – 0.0905 2012 – 0.0905
$N_{P,Coal,y}^E$	MWh/t	average electricity consumption per tonne of coal for the processing technology of rock on the beneficiation plant	Calculation the cost of electricity for the processing technology of rock on the beneficiation plant (See Annex 4)	0.015

**D.1.1. Option 1 – Monitoring of the emissions in the project scenario and the baseline scenario:****D.1.1.1. Data to be collected in order to monitor emissions from the project, and how these data will be archived:**

ID number (Please use numbers to ease cross-referencing to D.2.)	Data variable	Source of data	Data unit	Measured (m), calculated (c), estimated (e)	Recording frequency	Proportion of data to be monitored	How will the data be archived? (electronic/paper)	Comment
P1	$FC_{PE,Diesel,y}$ – Amount of diesel fuel, consumed in project in year y	Company records	t	M	Щомісяця	100%	In paper and electronic form	
P2	$NCV_{Diesel}$ – Net Calorific Value of diesel fuel	See section D.1. Fixed ex ante	TJ/kt	E	Fixed ex ante	100%	In electronic form	
P3	$OXID_{Diesel}$ - Carbon Oxidation factor of diesel fuel	See section D.1. Fixed ex ante	d/l	E	Fixed ex ante	100%	In electronic form	
P4	$K_{Diesel}^C$ - Carbon content of diesel fuel	See section D.1. Fixed ex ante	tC/TJ	E	Fixed ex ante	100%	In electronic form	

**D.1.1.2. Description of formulae used to estimate project emissions (for each gas, source etc.; emissions in units of CO<sub>2</sub> equivalent):**

Emissions from the project activity are calculated as follows:

$$PE_y = PE_{Diesel,y} \quad (7)$$

where:



$PE_y$  - project Emissions due to project activity in the year  $y$  ( tCO<sub>2</sub> equivalent),

$PE_{Diesel,y}$  - project Emissions due to consumption of diesel fuel by the project activity in the year  $y$  (tCO<sub>2</sub> equivalent).

Project Emissions due to consumption of diesel fuel by the project activity in the year  $y$  are calculated as follows:

$$PE_{Diesel,y} = \frac{FC_{PE,Diesel,y}}{1000} \cdot NCV_{Diesel} \cdot OXID_{Diesel} \cdot K_{Diesel}^c \cdot 44/12, \quad (9)$$

Where:

$FC_{PE,Diesel,y}$  - amount of diesel fuel, consumed in project in year  $y$ , t;

$NCV_{Diesel}$  - Net Calorific Value of diesel fuel, TJ/kt;

$OXID_{Diesel}$  - carbon Oxidation factor of diesel fuel, d/l;

$K_{Diesel}^c$  - carbon content of diesel, tC/TJ;

1/1000 - conversion factor from tons in kilotonnes, d/l

44/12 - stoichiometric relationship between the molecular weight of carbon dioxide and carbon, d/l.

<b>D.1.1.3. Relevant data necessary for determining the <u>baseline</u> of anthropogenic emissions of greenhouse gases by sources within the project boundary, and how such data will be collected and archived:</b>								
<b>ID number (Please use numbers to ease cross-referencing to D.2.)</b>	<b>Data variable</b>	<b>Source of data</b>	<b>Data unit</b>	<b>Measured (m), calculated (c), estimated (e)</b>	<b>Recording frequency</b>	<b>Proportion of data to be monitored</b>	<b>How will the data be archived? (electronic/paper)</b>	<b>Comment</b>



<i>B1</i>	$FC_{BE,Coal,y}$ - Amount of coal that has been mined in the baseline scenario and combusted for energy use in year y	Company records	t	<i>M</i>	Monthly	100%	In paper and electronic form	Equal to amount of coal extracted from dump. To measure this parameter using commercial data. Amount of coal confirmed by acts of acceptance from customers.
<i>B2</i>	$NCV_{Coal}$ - Net Calorific Value of coal	See section D.1. Fixed ex ante	TJ/kt	<i>E</i>	Fixed ex ante	100%	In electronic form	
<i>B3</i>	$OXID_{Coal}$ - Carbon Oxidation factor of coal	See section D.1. Fixed ex ante	d/l	<i>E</i>	Fixed ex ante	100%	In electronic form	
<i>B4</i>	$K_{coal}^c$ - Carbon content of coal	See section D.1. Fixed ex ante	tC/TJ	<i>E</i>	Fixed ex ante	100%	In electronic form	
<i>B5</i>	$p_{WHB}$ - Probability of waste heap burning	See section D.1. Fixed ex ante	d/l	<i>E</i>	Fixed ex ante	100%	In electronic form	

**D.1.1.4. Description of formulae used to estimate baseline emissions (for each gas, source etc.; emissions in units of CO<sub>2</sub> equivalent):**

Emissions in the baseline scenario are calculated as follows:

$$BE_y = BE_{WHB,y} \quad , \quad (10)$$

Where:

$BE_y$  – baseline Emissions in the year y (tCO<sub>2</sub>),



$BE_{WHB,y}$  - baseline Emissions due to burning of the waste heaps in the year y (tCO<sub>2</sub>),

Baseline emissions due to burning dumps in year y calculated by the formula:

$$BE_{WHB,y} = \frac{FC_{BE,Coal,y}}{1000} \cdot p_{WHB} \cdot NCV_{Coal} \cdot OXID_{Coal} \cdot K_{Coal}^c \cdot 44/12 \tag{11}$$

Where:

$FC_{BE,Coal,y}$  - amount of coal that has been mined in the baseline scenario and combusted for energy use, equivalent to the amount of coal extracted from the waste heaps because of the project activity in the year y, t;

$p_{WHB}$  - probability of waste heap burning, d/l;

$NCV_{Coal}$  - net Calorific Value of coal, TJ/kt;

$OXID_{Coal}$  - carbon Oxidation factor of coal, d/l;

$K_{Coal}^c$  - carbon content of coal, tC/TJ;

1/1000 - conversion factor from tons in kilotonnes, d / 1

44/12 - stoichiometric relationship between the molecular weight of carbon dioxide and carbon.

**D. 1.2. Option 2 – Direct monitoring of emission reductions from the project (values should be consistent with those in section E.):**

This section is left blank on purpose

**D.1.2.1. Data to be collected in order to monitor emission reductions from the project, and how these data will be archived:**

ID number (Please use numbers to ease cross-referencing to D.2.)	Data variable	Source of data	Data unit	Measured (m), calculated (c), estimated (e)	Recording frequency	Proportion of data to be monitored	How will the data be archived? (electronic/ paper)	Comment

This section is left blank on purpose



**D.1.2.2. Description of formulae used to calculate emission reductions from the project (for each gas, source etc.; emissions/emission reductions in units of CO<sub>2</sub> equivalent):**

This section is left blank on purpose

**D.1.3. Treatment of leakage in the monitoring plan:**

The result of this project is the net change (reduction) uncontrolled methane emissions due to of mining activity. As in the baseline scenario the supplying of coal is solely from mine, it leads to uncontrolled methane emissions. These emissions are calculated by applying the default emission factor for the country to the amount of coal extracted from the rock dumps in the project scenario (which is the same amount of coal extracted from mines in the baseline scenario). Carbon dioxide emissions due to electricity consumption in the coal mine way in an amount equivalent to the project amount of coal - a leakage, that can be taken into account at the base of State Statistics Committee<sup>43</sup> data on specific consumption of electricity at coal mines in Ukraine in the relevant year. Carbon dioxide emissions due to electricity consumption due to beneficiation of coal at beneficiation factory in the project scenario - a leakage that is considered on the base of standard calculation of specific energy consumption in the technological process of beneficiation.

These leakages are significant and will be included in the monitoring plan and calculating emission reductions for the project.

---

<sup>43</sup> <http://www.ukrstat.gov.ua/>



D.1.3.1. If applicable, please describe the data and information that will be collected in order to monitor leakage effects of the project:								
ID number (Please use numbers to ease cross-referencing to D.2.)	Data variable	Source of data	Data unit	Measured (m), calculated (c), estimated (e)	Recording frequency	Proportion of data to be monitored	How will the data be archived? (electronic/paper)	Comment
B1	$FC_{BE,Coal,y}$ - Amount of coal that has been mined in the baseline scenario and combusted for energy use in year y	Company records	t	M	Monthly	100%	In paper and electronic form	Equal to amount of coal extracted from dump. To measure this parameter using commercial data. Amount of coal confirmed by acts of acceptance from customers.
L1	$EF_{CO_2,EL}$ - Specific carbon dioxide emissions due to production of electricity at TPP and by its consumption	See section D.1. Fixed ex ante	tC/MW-h	E	Fixed ex ante	100%	In electronic form	
L2	$GWP_{CH_4}$ - Global Warming Potential of Methane	See section D.1. Fixed ex ante	tCO <sub>2</sub> / tCH <sub>4</sub>	E	Fixed ex ante	100%	In electronic form	



L3	$EF_{CH_4}$ - Emission factor for fugitive methane emissions from coal mining.	See section D.1. Fixed ex ante	$m^3/t$	$E$	Fixed ex ante	100%	In electronic form	
L4	$\rho_{CH_4}$ - Methane density at standart conditions	See section D.1. Fixed ex ante	$t/m^3$	$E$	Fixed ex ante	100%	In electronic form	
L5	$N_{B, Coal, y}^E$ - Average electricity consumption per tonne of coal, produced in Ukraine in the year y	See section D.1. Fixed ex ante	MWh/t	$E$	Fixed ex ante	100%	In electronic form	
L6	$N_{P, Coal, y}^E$ - Average electricity consumption per tonne of coal for the processing technology of rock on the beneficiation plant	See section D.1. Fixed ex ante	MWh/t	$C$	Fixed ex ante	100%	In electronic form	

**D.1.3.2. Description of formulae used to estimate leakage (for each gas, source etc.; emissions in units of CO<sub>2</sub> equivalent):**

Leakages in year y are calculated as follows:

$$LE_y = LE_{B,y} + LE_{P,y} \quad (10)$$

де:

$LE_y$  - leakages in year y, (t CO<sub>2</sub>e);

$LE_{B,y}$  - leakages in the baseline scenario in the year y, (t CO<sub>2</sub>e);

$LE_{P,y}$  - leakages in the project scenario in the year y, (t CO<sub>2</sub>e);

Leakages in baseline scenario year y are calculated as follows:

$$LE_{B,y} = LE_{CH_4,y} + LE_{B,EL,y} \quad (11)$$

де:

$LE_{B,y}$  - leakages in year y, (t CO<sub>2</sub>e);

$LE_{CH_4,y}$  - leakages due to fugitive emissions of methane in the mining activities in the year y, (t CO<sub>2</sub>e);

$LE_{B,EL,y}$  - leakages due to consumption of electricity from a grid at coal mine in a year y, (t CO<sub>2</sub>e);

Leakages due to fugitive emissions of methane in the mining activities in the year y are calculated as follows:

$$LE_{CH_4,y} = - FC_{BE,Coal,y} \cdot EF_{CH_4} \cdot \rho_{CH_4} \cdot GWP_{CH_4} \quad (12)$$

де:

$LE_{CH_4,y}$  - leakages due to fugitive emissions of methane in the mining activities in the year y, (t CO<sub>2</sub>e);

$FC_{BE,Coal,y}$  - amount of coal that has been mined in the baseline scenario and combusted for energy use, equivalent to the amount of coal extracted from the waste heaps because of the project activity in the year y, t;

$EF_{CH_4}$  - emission factor for fugitive methane emissions from coal mining, m<sup>3</sup>/t;

$\rho_{CH_4}$  - methane density at standart conditions t/m<sup>3</sup>;

$GWP_{CH_4}$  - Global Warming Potential of Methane, tCO<sub>2</sub>/tCH<sub>4</sub>.

Leakages due to consumption of electricity from a grid at coal mine in a year y are calculated as follows:

$$LE_{B,EL,y} = - FC_{BE,Coal,y} \cdot N_{B,Coal,y}^E \cdot EF_{CO_2,EL,y} \quad (13)$$

де:

$LE_{B,EL,y}$  - leakages due to consumption of electricity from a grid at coal mine in a year y, (t CO<sub>2</sub>e);



$FC_{BE,Coal,y}$  - amount of coal that has been mined in the baseline scenario and combusted for energy use, equivalent to the amount of coal extracted from the waste heaps because of the project activity in the year y, t;

$N_{B,Coal,y}^E$  - Average electricity consumption per tonne of coal, produced in Ukraine in the year y, MWh/t;

$EF_{CO_2,EL}$  - Specific carbon dioxide emissions due to production of electricity at TPP and by its consumption, tCO<sub>2</sub>/ MWh.

Leakages due to consumption of other types of energy in coal mines are the minor in comparison to the leakages due to electricity consumption<sup>44</sup>, so in connection with this, and for reasons of conservatism, take them equal to zero.

Leakages in baseline scenario year y are calculated as follows:

$$LE_{P,y} = LE_{P,EL,y} \quad (14)$$

where:

$LE_{P,EL,y}$  - leakages due to consumption of electricity from a grid at beneficiation plant in a year y, (t CO<sub>2</sub>e).

leakages due to consumption of electricity from a grid at beneficiation plant in a year y are calculated as follows:

$$LE_{P,EL,y} = FC_{BE,Coal,y} \cdot N_{P,Coal,y}^E \cdot EF_{CO_2,EL}; \quad (15)$$

where:

$FC_{BE,Coal,y}$  - amount of coal that has been mined in the baseline scenario and combusted for energy use, equivalent to the amount of coal extracted from the waste heaps because of the project activity in the year y, t;

$N_{P,Coal,y}^E$  - average electricity consumption per tonne of coal for the processing technology of rock on the beneficiation plant;

$EF_{CO_2,EL}$  - specific carbon dioxide emissions due to production of electricity at TPP and by its consumption, tCO<sub>2</sub>/ MWh.

**D.1.4. Description of formulae used to estimate emission reductions for the project (for each gas, source etc.; emissions/emission reductions in units of CO<sub>2</sub> equivalent):**

The annual emission reductions are calculated as follows:

$$ER_y = BE_y - PE_y - LE_y \quad (16)$$

Where:

$ER_y$  - emissions reductions of the JI project in year y (tCO<sub>2</sub> equivalent);

<sup>44</sup> The effective method of electricity consumption control at coal mines. B.A.Gryaduschy, Doctor of Technical. Science, DonUGI, G.N.Lisovoy, V.I.Myalkovsky, Chehlaty NA, Cand. Science, NIIGM named M.M.Fedorov, Donetsk, Ukraine [www.mishor.esco.co.ua/2005/Thesis/10.doc](http://www.mishor.esco.co.ua/2005/Thesis/10.doc)



$BE_y$  - baseline Emission in year y (tCO<sub>2</sub> equivalent);

$PE_y$  - project Emission in year y (tCO<sub>2</sub> equivalent).

$LE_y$  - leakages in year y, (tCO<sub>2</sub> equivalent)

**D.1.5. Where applicable, in accordance with procedures as required by the host Party, information on the collection and archiving of information on the environmental impacts of the project:**

Collection and archiving of the information on the environmental impacts of the project will be done based on the approved EIA in accordance with the Host Party legislation - *State Construction Standard DBN A.2.2.-1-2003 : "Structure and Contents of the Environmental Impact Assessment Report (EIR) for Designing and Construction of Production Facilities, Buildings and Structures"*<sup>45</sup> State Committee Of Ukraine On Construction And Architecture, 2004 (see Section F.1).

**D.2. Quality control (QC) and quality assurance (QA) procedures undertaken for data monitored:**

Data (Indicate table and ID number)	Uncertainty level of data (high/medium/low)	Explain QA/QC procedures planned for these data, or why such procedures are not necessary.
B1	Low	These data are used in commercial activities of the company. The weights will be calibrated according to the procedures of the Host Party. Calibration interval is 1 year.
B2-B4	Low	These data are fixed values and standard constants taken from regular sources
B5	Medium	These data are fixed values and standard constants taken from regular sources
P1	Low	This data are used in the commercial activity of the company. Accounting documentation will be used.
P2-P4	Low	These data are fixed values and standard constants taken from regular sources
L1-L5	Low	These data are fixed values and standard constants taken from regular sources
L6	Low	These data represent the standard calculation of beneficiation plant and used in a commercial activity of the company.

**D.3. Please describe the operational and management structure that the project operator will apply in implementing the monitoring plan:**

LLC "Trading House "Metalprom" is the owner of the project, which will implement the provisions of this monitoring plan with its organizational and management structure. Leadership, headed by the director of the company is responsible for performance of monitoring, data collection, registration, visualization, storage and reporting of data that were monitored, and periodic inspection of measuring instruments. Detailed structure and senior staff members of the Management Group will be submitted in the monitoring before the initial and first periodic verification. The basic structure demonstrated by the following block diagram:

<sup>45</sup> <http://document.ua/proektuvannja.-sklad-i-zmist-materialiv-ocinki-vpliviv-na-na-nor3146.html>

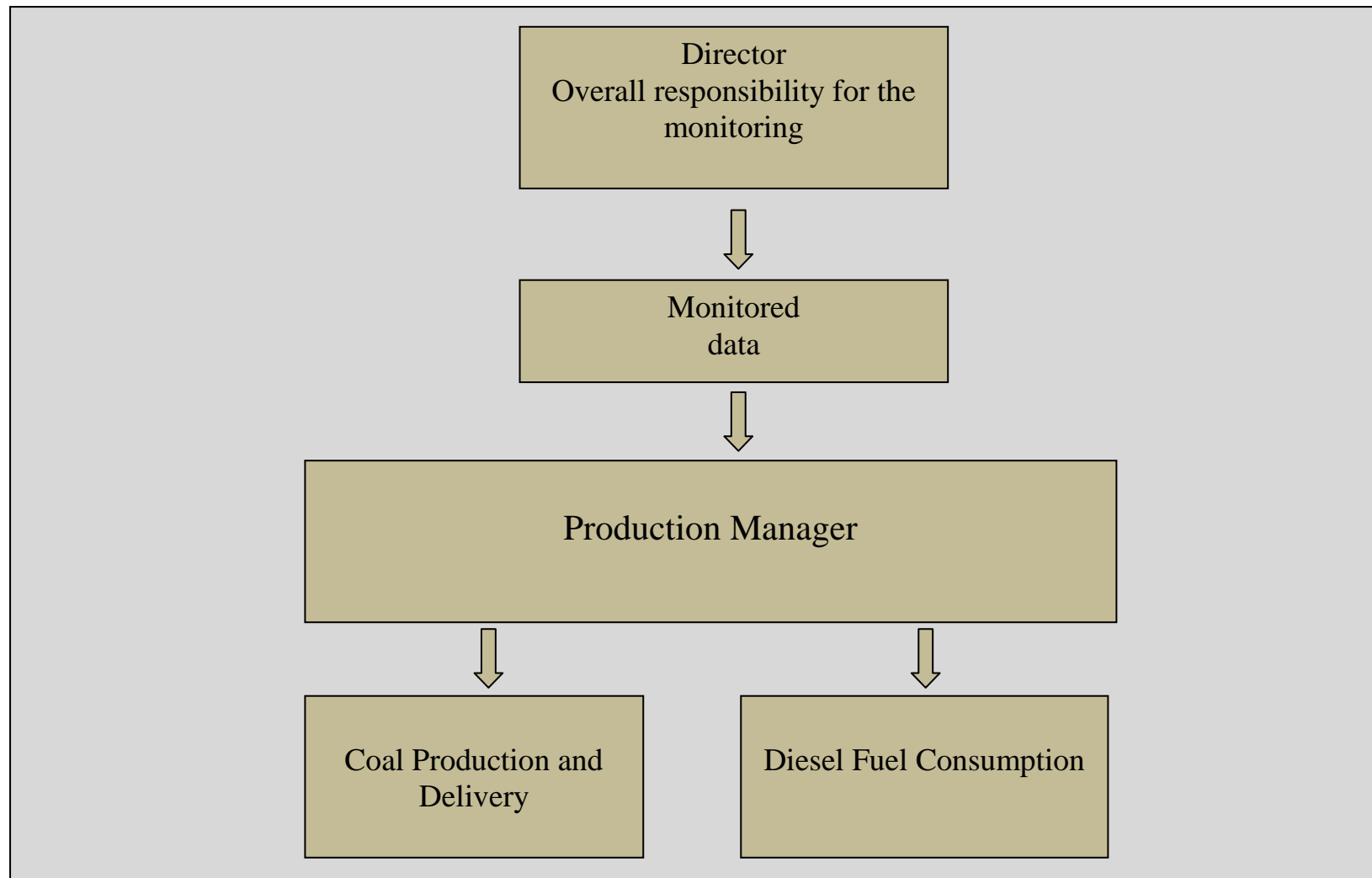

Figure 11 - Monitoring flowchart





**D.4. Name of person(s)/entity(ies) establishing the monitoring plan:**

Ivanenko Gennadiy V, Project manager at SIA “Vidzeme Eko”, which is the project participant. ., tel.+38044 222 61 63, fax.+38044 222 61 63, e-mail:[info@ekoji.lv](mailto:info@ekoji.lv) . Please, refer to Annex 1 for contact details.

**SECTION E. Estimation of greenhouse gas emission reductions**

This section contains the assessment of GHG emissions reductions. Calculations carried out using the formulas described in detail in Section D of this document.

**E.1. Estimated project emissions**

Table 14 - Estimated project emissions during the crediting period

			2009	2010	2011	2012	Total
1	Project Emissions due to consumption of diesel fuel by the project activity	tCO <sub>2</sub>	2336	9516	9617	5708	27177
	Total in 2009-2012 yy.	tCO <sub>2</sub> equivalent	<b>27 177</b>				

**E.2. Estimated leakage:**

Table 15 – Estimated leakages during crediting period

			2009	2010	2011	2012	Total
1	Leakages due to fugitive emissions of methane in mining activity	tCO <sub>2</sub>	-18044	-77104	-81897	-52604	-229649
2	Leakages due to consumption of electricity from grid in mining activity	tCO <sub>2</sub>	-5593	-24216	-25179	-16173	-71161
3	Leakages due to consumption of electricity from grid at beneficiation plant	tCO <sub>2</sub>	927	3923	4173	2681	11704
	Total	tCO <sub>2</sub>	-22710	-97397	-102903	-66096	-289106
	Total in 2009-2012 yy.	tCO <sub>2</sub> equivalent	<b>-289106</b>				

**E.3. The sum of E.1. and E.2.:**

Table 16 - Estimated total project emissions during the crediting period

			2009	2010	2011	2012	Total
1	Total Project emissions during the crediting period	tCO <sub>2</sub> equivalent	-20374	-87881	-93286	-60388	-261929

**E.4. Estimated baseline emissions:**

Table 17- Estimated baseline emissions during the crediting period

			2009	2010	2011	2012	Total
<b>1</b>	Baseline Emissions due to burning of the waste heaps in the year y	tCO <sub>2</sub>	82893	350866	372676	239379	1045814
	Total for 2009-2012 yy.	tCO <sub>2</sub> equivalent	<b>1 045 814</b>				

**E.5. Difference between E.4. and E.3. representing the emission reductions of the project:**

Table 18 - Estimated emission reductions during the crediting period

		2009	2010	2011	2012	Total
Emission reductions during the crediting period	tCO <sub>2</sub> e	103267	438747	465962	299767	1307743
Total 2009-2012 yy.	tCO <sub>2</sub> equivalent	<b>1 307 743</b>				

**E.6. Table providing values obtained when applying formulae above:**

Table 19 - Estimated balance of emissions under the proposed project during the crediting period

Year	Estimated Project Emissions (tonnes CO <sub>2</sub> equivalent)	Estimated Leakage (tonnes CO <sub>2</sub> equivalent)	Estimated Baseline Emissions (tonnes CO <sub>2</sub> equivalent)	Estimated Emissions Reductions (tonnes CO <sub>2</sub> equivalent)
2009	2336	-22710	82893	103267
2010	9516	-97397	350866	438747
2011	9617	-102903	372676	465962
2012	5708	-66096	239379	299767
Total (tCO <sub>2</sub> equivalent)	<b>27177</b>	<b>-289106</b>	<b>1045814</b>	<b>1307743</b>

**SECTION F. Environmental impacts****F.1. Documentation on the analysis of the environmental impacts of the project, including transboundary impacts, in accordance with procedures as determined by the host Party:**

Activity of LLC "Trading House"Metalprom" is undertaken under the current legislation of Ukraine, in particular, according to the Laws of Ukraine "On Environmental Protection", "On Ecological Expertise", "On Air Protection", "On Waste" and other applicable rules and regulations<sup>46</sup>.

The Host Party for this project is Ukraine. Environmental Impact Assessment (EIA) is the part of the Ukrainian project planning and permitting procedures. Implementation regulations for EIA are included in the Ukrainian State Construction Standard DBN A.2.2.-1-200347 (Title:"Structure and Contents of the Environmental Impact Assessment Report (EIR) for Designing and Construction of Production Facilities, Buildings and Structures").

Annex F of this standard contains a list of "types of projects or activities which constitute higher environmental risk" for which full EIA is mandatory, and the Ministry of Environment being the competent authority. Project activity, which is the utilization of coal mining waste and production of coal, is included in this list.

The full scope EIA in accordance with the Ukrainian legislation has been conducted for the beneficiation factory LLC "PC" Donetsk coal fuel " in 2007 by the project designer "Project Office "Ecoservice". Key findings of this EIA are summarized below:

- Impact on air is the main environmental impact of the project activity. Dust emissions due to the erosion and project activity such as loading and offloading operations of input rock and processed coal will be limited. Also emissions from transport will be present during the project operation stage. The impact will not exceed maximum allowable concentration at the edge of the sanitary zone;
- Impact on water is minor. The project activity will use water in a closed cycle without discharge of waste water. The possible discharge of the processed water will not have negative impact on the quality of water in the surface reservoirs;
- Impacts on flora and fauna are insignificant. The design documentation demands re-cultivation of the landscape. Grass and trees will be planted on the re-cultivated areas in order to prevent flora and fauna degradation. No rare or endangered species will be impacted. Project activity is not located in the vicinity of national parks or protected areas;
- Noise impact is limited. Main source of noise will be located at the minimum required distance from residential areas, mobile noise sources (automobile transport) will be in compliance with local standards;
- Impacts on land use are positive. Significant portions of land will be freed from the waste heaps and will be available for development. Fertile soil will be used to recultivate the land lot;
- Transboundary impacts are not observed. There are no impacts that manifest within the area of any other country and that are caused by a proposed project activity which wholly physically originates within the area of Ukraine.

**F.2. If environmental impacts are considered significant by the project participants or the host Party, please provide conclusions and all references to supporting documentation of an environmental impact assessment undertaken in accordance with the procedures as required by the host Party:**

Assessment of impact on the environment under the laws of Ukraine was held for the proposed project in 2007 by the project designer "Project Office "Ecoservice". According to Ukrainian laws and regulations, preparation of reports on evaluation of environmental impact and the positive conclusions of the State Department of Environment and Natural Resources in Donetsk region is the procedure of environmental impact assessment.

<sup>46</sup> <http://www.budinfo.com.ua/dbn/8.htm>

**SECTION G. Stakeholders' comments****G.1. Information on stakeholders' comments on the project, as appropriate:**

The project meets the applicable standards and requirements, set forth in Ukraine. The Host Party does not put forward the requirement to consult with stakeholders to JI projects. Stakeholders' comments will be collected during the publication of the project documents on the Internet during the determination process.

Annex 1**CONTACT INFORMATION ON PROJECT PARTICIPANTS**

Organisation:	LLC "Trading House"Metalprom"
Street/P.O.Box:	Olimpieva
Building:	198
City:	Donetsk
State/Region:	Donetsk
Postal code:	83049
Country:	Ukraine
Phone:	+38062 388-80-45
Fax:	+38099 410-89-89
E-mail:	<a href="mailto:metprom.dn@gmail.com">metprom.dn@gmail.com</a>
URL:	
Represented by:	Roman Gazizov
Title:	Director
Salutation:	Mr.
Last name:	Gazizov
Middle name:	Valeriyovich
First name:	Roman
Department:	
Phone (direct):	+38062 388-80-45
Fax (direct):	+38062 388-80-45
Mobile:	+38099 410-89-89
Personal e-mail:	

Organisation:	SIA "Vidzeme Eko"
Street/P.O.Box:	Zolitudes
Building:	46 k-2 -76
City:	Riga
State/Region:	
Postal code:	LV-1029
Country:	Latvia
Phone:	+371 29518171
Fax:	+371 67284770
E-mail:	<a href="mailto:info@ekoji.lv">info@ekoji.lv</a>
URL:	<a href="http://www.holdings.lv">http://www.holdings.lv</a>
Represented by:	Mikus Vilsons
Title:	Director
Salutation:	Mr
Last name:	Vilsons
Middle name:	
First name:	Mikus
Department:	
Phone (direct):	
Fax (direct):	
Mobile:	+371 29518171
Personal e-mail:	



Organisation:	SIA "Vidzeme Eko"
Street/P.O.Box:	Zolitudes
Building:	46 k-2 -76
City:	Riga
State/Region:	
Postal code:	LV-1029
Country:	Latvia
Phone:	+371 29518171
Fax:	+371 67284770
E-mail:	info@ekoji.lv
URL:	<a href="http://www.holdings.lv">http://www.holdings.lv</a>
Represented by:	Aleksandrs Fridkins
Title:	Finance director
Salutation:	Mr.
Last name:	Fridkins
Middle name:	
First name:	Aleksandrs
Department:	
Phone (direct):	
Fax (direct):	
Mobile:	+371 29442040
Personal e-mail:	

Organisation:	SIA "Vidzeme Eko"
Street/P.O.Box:	Zolitudes
Building:	46 k-2 -76
City:	Riga
State/Region:	
Postal code:	LV-1029
Country:	Latvia
Phone:	+371 29518171
Fax:	+371 67284770
E-mail:	<a href="mailto:info@ekoji.lv">info@ekoji.lv</a>
URL:	<a href="http://www.holdings.lv">http://www.holdings.lv</a>
Represented by:	Viktor Tkachenko
Title:	Official representative in Ukraine
Salutation:	Mr
Last name:	Tkachenko
Middle name:	
First name:	Viktor
Department:	
Phone (direct):	+38095 272 45 74
Fax (direct):	
Mobile:	
Personal e-mail:	

Organisation:	SIA "Vidzeme Eko"
---------------	-------------------





Street/P.O.Box:	Zolitudes
Building:	46 k-2 -76
City:	Riga
State/Region:	
Postal code:	LV-1029
Country:	Latvia
Phone:	+371 29518171
Fax:	+371 67284770
E-mail:	<a href="mailto:info@ekoji.lv">info@ekoji.lv</a>
URL:	<a href="http://www.holdings.lv">http://www.holdings.lv</a>
Represented by:	Ivanenko Gennadiy
Title:	Project Manager
Salutation:	Mr.
Last name:	Ivanenko
Middle name:	
First name:	Gennadiy
Department:	
Phone (direct):	+38044 222 61 63
Fax (direct):	
Mobile:	
Personal e-mail:	



Annex 2

**BASELINE INFORMATION**

See Section B in PDD



Annex 3

**MONITORING PLAN**

See section D in PDD for monitoring plan description

Annex 4**Calculation the cost of electricity for the processing technology of rock on the beneficiation plant**

This calculation is based on the technological process of processing rock mass with productivity of 200 tons per hour. Output of the final product is according to the balance of processing.

**1. The preparatory work.** From the rock mass by Conveyor SP- 80K capacity 40 kW the rock mass is supplied on a two belt conveyors with a capacity of 7 kW.

For preliminary screening, the rock mass from conveyor belt supplied trough spout of sifter HYSL-72 with power 44kW and pump SHN-500 (100 kW) water from the tank is fed to sprinclar. Then oversize product of sifter arrives at the stage of preparatory screening for vibrating sifter HYSL-52 by capacity 17 kW. The product after two stages of screening by four belt conveyors with a capacity of 7 kW goes to enrichment.

Specific electricity consumption:

$$E_1 = \frac{N_1^1 + N_2^1 + N_3^1 + N_4^1 + N_5^1 + N_6^1 + N_7^1 + N_8^1 + N_9^1 + N_{10}^1}{P * C\%} = \frac{40 + 7 + 7 + 44 + 100 + 17 + 7 + 7 + 7 + 7}{200 * 34\%} = 3.573 \text{ kWh/t}$$

**2. Benefication.** From conveyor the material is supplied to the benefication in a heavy media separator SKV-20 power 8 kW, and circulated water supplied by the pump SHN-500 power 100 kW and then – on vibrating sifter GIS-52 power 17 kW, and pump for fine class SHN-250 power 55kVt. Oversize product (klas13-100mm) shall be submitted to the vibrating sifter HYSL-72 power 44 kW, and the water is supplied by a pump SHN-250 capacity of 55 kW. Product Class 3-13mm is supplied on two screens HYSL-52 with total capacity of 34 kW for end desliming. Oversize product is fed into the centrifuge PVSH-950 power 55 kW. Undersize product enters to the collector of slime water where the slurry thickening and filtration occur. Suspension regeneration system includes regeneration of the circulating water as a secondary process that occurs with a pump power of SHN-250 55 kW.

Specific electricity consumption:

$$E_2 = \frac{N_1^2 + N_2^2 + N_3^2 + N_4^2 + N_5^2 + N_6^2 + N_7^2 + N_8^2 + N_9^2}{P * C\%} = \frac{8 + 100 + 17 + 55 + 44 + 55 + 34 + 55 + 55}{200 * 34\%} = 6.22 \text{ kWh/t}$$

**3. Shipment into the bunker.** Species using the feeder CL-8 capacity of 8 kW is supplied on two belt conveyors with a capacity of 7 kW. Concentrate is shipped by belt conveyors for two routes: the first route - 1 pc to 7 kW, the second route, 3pcs of 7 kW.

Specific electricity consumption:

$$E_3 = \frac{N_1^3 + N_2^3 + N_3^3 + N_4^3 + N_5^3 + N_6^3 + N_7^3}{P * C\%} = \frac{8 + 7 + 7 + 7 + 7 + 7 + 7}{200 * 34\%} = 0.735 \text{ kWh/t}$$

**4. Re-benefication and control dehydration.** During the control benefication the concentrate fed to the screw separator capacity of 8 kW and using SHN-250 capacity of 55 kW is feed the primary slimes, then control dehydration of concentrate occur. Then the concentrate is fed to the HYL-52 (2pcs) of 17kW and using SHN-250 (1pc) with capacity 55 kW secondary slimes are supplied. Then the concentrate is sent to the centrifuge PVSH-950 with power 55kW. Control dehydration of material also occurs on spiral separators.

Specific electricity consumption:

$$E_4 = \frac{N_1^4 + N_2^4 + N_3^4 + N_4^4 + N_5^4 + N_6^4}{P * C\%} = \frac{8 + 55 + 17 + 17 + 55 + 55}{200 * 34\%} = 3,044 \text{ kWh/t}$$

**5. Transporting into the bunkers.** The final product - the concentrate through the conveyor belt capacity of 7 kW comes to the storage tank and rock conveyor belt capacity of 7kW shipped in accumulating rock hopper.



Specific electricity consumption:

$$E_5 = \frac{N_1^5 + N_2^5}{P * C\%} = \frac{7+7}{200 * 34\%} = 0,206 \text{ kWh/t}$$

**6. Shipment of concentrate on vehicles.** From storage tank the material by two feeders CL-8 with power 8kW fed to the conveyor belts (4pcs.) with capacity 7 kW by which products are shipped on trucks. Also used the loading winch with capacity 2 kW.

Specific electricity consumption:

$$E_6 = \frac{N_1^6 + N_2^6 + N_3^6 + N_4^6 + N_5^6 + N_6^6 + N_7^6}{P * C\%} = \frac{8+8+7+7+7+7+2}{200 * 34\%} = 0,676 \text{ kWh/t}$$

**7. Transportation of waste** After the processing useless waste by feeders CL-8 (2pcs.) with capacity 8 kW loaded on two conveyor belts with 7 kW and transported on a flat dump.

Specific electricity consumption:

$$E_7 = \frac{N_1^7 + N_2^7 + N_3^7 + N_4^7 + N_5^7}{P * C\%} = \frac{8+8+7+7+7}{200 * 34\%} = 0,544 \text{ kWh/t}$$

Overall calculation of specific energy consumption per tonne of enriched coal:

$$E = E_1 + E_2 + E_3 + E_4 + E_5 + E_6 + E_7 = 3,573 + 6,22 + 0,735 + 3,044 + 0,206 + 0,676 + 0,544 = \mathbf{14,99 \text{ kWh/t}}$$