



# VERIFICATION REPORT

“RIVNETEPLOENERGO”, LTD

## DISTRICT HEATING SYSTEM REHABILITATION IN RIVNE REGION

PERIODIC 2008

REPORT No. UKRAINE/0078/2009

REVISION No. 01

BUREAU VERITAS CERTIFICATION

## VERIFICATION REPORT

Date of first issue: 22/12/2009	Organizational unit: Bureau Veritas Certification Holding SAS
Client: "Rivneteploenergo", Ltd	Client ref.: Mr. Stepan Koropetskiy

**Summary:**

Bureau Veritas Certification has made the verification of the "District Heating System Rehabilitation in Rivne Region" project of "Rivneteploenergo", Ltd., located in Rivne Region, on the basis of UNFCCC criteria for the JI, as well as the host country criteria and criteria given to provide for consistent project operations, monitoring and reporting, as well as the host country criteria.

The verification scope is defined as a periodic independent review and ex post determination by the Accrediting Entity of the monitored reductions in GHG emissions during defined verification period, and consisted of the following three phases: i) desk review of the Monitoring Report, Project Design Document and the baseline and monitoring plan; ii) follow-up interviews with project stakeholders; iii) resolution of outstanding issues and the issuance of the final verification report and opinion. The overall verification, from Contract Review to Verification Report & Opinion, was conducted using Bureau Veritas Certification internal procedures. The first output of the verification process is a list of Clarification Requests, Corrective Actions Requests, Forward Actions Requests (CL, CAR and FAR), presented in Appendix A.

In summary, Bureau Veritas Certification confirms that the project is implemented as planned and described in validated project design documents. Installed equipment being essential for generating emission reduction runs reliably and is calibrated appropriately. The monitoring system is in place and the GHG emission reduction is calculated without material misstatements.

Our opinion relates to the project's GHG emissions and resulting GHG emissions reductions reported and related to the valid project baseline and monitoring, and its associated documents. Based on information seen and evaluated we confirm that the implementation of the project has resulted in 45248t CO<sub>2</sub>e reductions during period from 01/01/2008 up to 31/12/2008.

On the behalf of verification team, Flavio Gomes, the Bureau Veritas Certification Holding SAS Global Product Manager for Climate Change, approved final version of the Verification Report and it is signed by Ivan Sokolov authorized Bureau Veritas Certification Holding SAS Local product manager for Climate Change in Ukraine.

Report No.: UKRAINE/0078/2009	Subject Group: JI	
Project title: District Heating System Rehabilitation in Rivne Region		
Work carried out by: Team Leader : Nadiia Kaiun Team Member : Kateryna Zinevych Specialist : Iuliia Gumeniuk		
Work verified by: Ivan Sokolov		
Date of this revision: 22/12/2009	Rev. No.: 01	Number of pages: 64

**Indexing terms**

Climate Change, Kyoto Protocol, Emission reductions, Verification

No distribution without permission from the Client or responsible organizational unit

Limited distribution

Unrestricted distribution



## Abbreviations change

AIE	Accredited Independent Entity
BVCH	Bureau Veritas Certification Holding SAS
CAR	Corrective Action Request
CER	Certified Emission Reductions
CL	Clarification Request
CO <sub>2</sub>	Carbon Dioxide
FAR	Forward Action Request
GHG	Green House Gas(es)
IETA	International Emissions Trading Association
JI	Joint Implementation
JISC	JI Supervisory Committee
MoV	Means of Verification
MP	Monitoring Plan
PCF	Prototype Carbon Fund
PDD	Project Design Document
UNFCCC	United Nations Framework Convention on Climate Change
DH	District Heating



<b>Table of Contents</b>		<b>Page</b>
1	INTRODUCTION .....	5
1.1	Objective	5
1.2	Scope	6
1.3	GHG Project Description	6
2	METHODOLOGY .....	7
2.1	Review of Documents	11
2.2	Follow-up Interviews	11
2.3	Resolution of Clarification, Corrective and Forward Action Requests	12
3	VERIFICATION FINDINGS .....	12
3.1	Remaining issues CAR's, FAR's from previous verification	13
3.2	Project Implementation	13
3.3	Internal and External Data	18
3.5	Management and Operational System	20
4	SECOND PERIODIC VERIFICATION FINDINGS.....	21
4.1	Completeness of Monitoring	21
4.2	Accuracy of Emission Reduction Calculations	22
4.3	Quality Evidence to Determine Emissions Reductions	23
4.4	Management System and Quality Assurance	23
5	PROJECT SCORECARD .....	25
6	SECOND VERIFICATION STATEMENT.....	25
7	REFERENCES .....	26
	APPENDIX A: COMPANY JI PROJECT VERIFICATION PROTOCOL.....	28
	APPENDIX B: VERIFICATION TEAM .....	54
	APPENDIX C: DOCUMENTS CHECKED DURING VERIFICATION.....	56
	APPENDIX C: DOCUMENTS CHECKED DURING VERIFICATION .....	53



## 1 INTRODUCTION

“Rivneteploenergo”, Ltd has commissioned Bureau Veritas Certification to verify the emissions reductions of its JI project “Rivneteploenergo”, Ltd (hereafter called “the project”) in Rivne Region, UNFCCC JI Reference Number 0007.

This report summarizes the findings of second periodic verification of the project, performed on the basis of criteria given to provide for consistent project operations, monitoring and reporting, and contains a statement for the verified emission reductions.

The order includes the second periodic verification of the project. Report is based on the Periodic Verification Report Template Version 3.0, December 2003, both part of the Validation and Verification Manual (VVM) published by International Emission Trading Association (IETA).

The results of the determination were documented by "Climate and Energy" of Bureau Veritas Certification in the report: "Determination of the “District Heating System Rehabilitation in Rivne Region” JI-Project, Ukraine", Report UKRAINE-0047/2009.

Project is approved by National Environmental Investment Agency of Ukraine (Letter of Approval #1513/23/7 dated 14<sup>th</sup> of December 2009, see References).

### 1.1 Objective

Verification is the periodic independent review and ex post determination by the AIE of the monitored reductions in GHG emissions during defined verification period.

The objective of verification can be divided in Initial Verification and Periodic Verification.

**Initial Verification:** The objective of an initial verification is to verify that the project is implemented as planned, to confirm that the monitoring system is in place and fully functional, and to assure that the project will generate verifiable emission reductions. A separate initial verification prior to the project entering into regular operations is not a mandatory requirement.

**Periodic Verification:** The objective of the periodic verification is to verify that actual monitoring systems and procedures are in compliance with the monitoring systems and procedures described in the monitoring plan; furthermore the periodic verification evaluates the GHG emission reduction data and express a conclusion with a high, but not absolute, level of assurance about whether the reported GHG emission reduction data is free of material misstatements; and verifies that the reported GHG



---

**VERIFICATION REPORT**

---

emission data is sufficiently supported by evidence, i.e. monitoring records.

In general, the verification follows UNFCCC criteria referring to the Kyoto Protocol criteria, the JI rules and modalities, and the subsequent decisions by the JISC, as well as the host country criteria.

## **1.2 Scope**

Verification scope is defined as an independent and objective review and ex post determination by the Designated Operational Entity of the monitored reductions in GHG emissions. The verification is based on the submitted monitoring report and the determined project design document including the project's baseline study and monitoring plan and other relevant documents. The information in these documents is reviewed against Kyoto Protocol requirements, UNFCCC rules and associated interpretations. Bureau Veritas Certification has, based on the recommendations in the Validation and Verification Manual employed a risk-based approach in the verification, focusing on the identification of significant risks of the project implementation and the generation of ERUs.

The verification is not meant to provide any consulting towards the Client. However, stated requests for forward actions and/or corrective actions may provide input for improvement of the project monitoring towards reductions in the GHG emissions.

The audit team has been provided with a Monitoring Report version 2 and underlying data records, covering the period 01 January 2008 to 31 December 2008 inclusive.

## **1.3 GHG Project Description**

The project main goal is fuel consumption reduction, in particular reduction of natural gas (which is imported to Ukraine), coal and oil consumption, by means of district heating system rehabilitation in Rivne region, including boiler and distribution network equipment replacement and rehabilitation, and installation of combined heat and power production plants. Such reduction of fuel consumption will result in decrease of greenhouse gas emissions (CO<sub>2</sub> and N<sub>2</sub>O). The purpose of the project is sustainable development of the region through implementation of energy saving technologies.

Rivne region's district heating (DH) utility (system of heat supply enterprises) supplies and sells heat energy in forms of heat and hot water to local consumers, namely households, municipal consumers and state-owned organizations. It is a natural monopolist of heat production in the region. Heat supply market in the region is stable for years.

VERIFICATION REPORT

---

The project was initiated in 2002 to rehabilitate Rivne region's district heating system, including boiler and distribution network equipment replacement and rehabilitation, installation of cogeneration units and frequency controllers installation.

The project consists of two parts: rehabilitation of DH system of Rivne city and rehabilitation of DH system of Rivne region. 12 boiler-houses with 78 boilers and 110 km of heat distributing networks are involved in the rehabilitation of Rivne city and 7 boiler-houses with 19 boilers and 11 km of heat distributing networks are involved in the rehabilitation of Rivne region. The total number of boiler-houses which are involved in the project is 19 with 97 boilers and 121 km heat distribution networks. Beside this project provides installation of cogeneration units at boiler houses Knyazya Volodymyra, 71 (two steam-turbines 2,5 MW each). This is the large part of Rivne regional DH system.

The project employs the increase in fuel consumption efficiency to reduce greenhouse gas emissions relative to current practice. Reduction of fuel consumption is based on increase of the boiler efficiencies, reduction of heat losses in networks, CHP and frequency controllers installation. The following activities will ensure fuel saving:

- Replacement of old boilers by new highly efficient boilers;
- Upgrading of boilers' burners;
- Fuel switch from coal and fuel oil to natural gas;
- Improving of the network organization, application of the new insulation and the pre-insulated pipes;
- Installation of CHP;
- Installation of frequency controllers at smoke exhauster and hot water pumps engines.
- Installation of air heaters;
- Partial replacement of fossil fuel by the renewable sources of fuel such as wood and wood chips (expansion of this tendency).

## 2 METHODOLOGY

The verification is as a desk review and field visit including discussions and interviews with selected experts and stakeholders.

In order to ensure transparency, a verification protocol was customized for the project, according to the Validation and Verification Manual (IETA/PCF) a verification protocol is used as part of the verification. The protocol shows, in a transparent manner, criteria (requirements), means of verification and the results from verifying the identified criteria. The verification protocol serves the following purposes:

- It organises, details and clarifies the requirements the project is expected to meet; and
- It ensures a transparent verification process where the verifier will documents how a particular requirement has been verified and the result of the verification.



VERIFICATION REPORT

The verification protocol consists of one table under Initial Verification checklist and four tables under Periodic verification checklist. The different columns in these tables are described in Figure 1.

The overall verification, from Contract Review to Verification Report & Opinion, was conducted using Bureau Veritas Certification procedures.

The completed verification protocol is enclosed in Appendix A to this report.

<b>Initial Verification Protocol Table 1</b>			
<b>Objective</b>	<b>Reference</b>	<b>Comments</b>	<b>Conclusion (CARs/FARs)</b>
The requirements the project must meet	Gives reference to where the requirement is found.	Description of circumstances and further comments on the conclusion	This is either acceptable based on evidence provided (OK), or a Corrective Action Request (CAR) of risk or non-compliance of the stated requirements. Forward Action Request (FAR) indicates essential risks for further periodic verifications.

<b>Periodic Verification Checklist Protocol Table 2: Data Management System/Controls</b>		
<b>Identification of potential reporting risk</b>	<b>Identification, assessment and testing of management controls</b>	<b>Areas of residual risks</b>
The project operator's data management system/controls are assessed to identify reporting risks and to assess the data management system's/control's ability to mitigate reporting risks. The GHG data management system/controls are assessed against the expectations detailed in the table.	A score is assigned as follows: <ul style="list-style-type: none"> <li>• Full - all best-practice expectations are implemented.</li> <li>• Partial - a proportion of the best practice expectations is implemented</li> <li>• Limited - this should be given if little or none of the system component is in place.</li> </ul>	Description of circumstances and further commendation to the conclusion. This is either acceptable based on evidence provided (OK), or a Corrective Action Request (CAR) of risk or non compliance with stated requirements. The corrective action requests are numbered and presented to the client in the verification report. The Initial Verification has additional Forward Action Requests (FAR). FAR indicates essential risks for further periodic verifications.

<b>Periodic Verification Protocol Table 3: GHG calculation procedures and management control testing</b>		
<b>Identification of potential reporting risk</b>	<b>Identification, assessment and testing of management controls</b>	<b>Areas of residual risks</b>
Identify and list potential reporting	Identify the key controls for each area	Identify areas of residual





VERIFICATION REPORT

<p>risks based on an assessment of the emission estimation procedures, i.e.</p> <ul style="list-style-type: none"> <li>➤ the calculation methods,</li> <li>➤ raw data collection and sources of supporting documentation,</li> <li>➤ reports/databases/information systems from which data is obtained.</li> </ul> <p>Identify key source data. Examples of source data include metering records, process monitors, operational logs, laboratory/analytical data, accounting records, utility data and vendor data. Check appropriate calibration and maintenance of equipment, and assess the likely accuracy of data supplied.</p> <p>Focus on those risks that impact the accuracy, completeness and consistency of the reported data. Risks are weakness in the GHG calculation systems and may include:</p> <ul style="list-style-type: none"> <li>➤ manual transfer of data/manual calculations,</li> <li>➤ unclear origins of data,</li> <li>➤ accuracy due to technological limitations,</li> <li>➤ lack of appropriate data protection measures? For example, protected calculation cells in spreadsheets and/or password restrictions.</li> </ul>	<p>with potential reporting risks. Assess the adequacy of the key controls and eventually test that the key controls are actually in operation.</p> <p>Internal controls include (not exhaustive):</p> <ul style="list-style-type: none"> <li>➤ Understanding of responsibilities and roles</li> <li>➤ Reporting, reviewing and formal management approval of data;</li> <li>➤ Procedures for ensuring data completeness, conformance with reporting guidelines, maintenance of data trails etc.</li> <li>➤ Controls to ensure the arithmetical accuracy of the GHG data generated and accounting records e.g. internal audits, and checking/ review procedures;</li> <li>➤ Controls over the computer information systems;</li> <li>➤ Review processes for identification and understanding of key process parameters and implementation of calibration maintenance regimes</li> <li>➤ Comparing and analysing the GHG data with previous periods, targets and benchmarks.</li> </ul> <p>When testing the specific internal controls, the following questions are considered:</p> <ol style="list-style-type: none"> <li>1. Is the control designed properly to ensure that it would either prevent or detect and correct any significant misstatements?</li> <li>2. To what extent have the internal controls been implemented according to their design;</li> <li>3. To what extent have the internal controls (if existing) functioned properly (policies and procedures have been followed) throughout</li> </ol>	<p>risks, i.e. areas of potential reporting risks where there are no adequate management controls to mitigate potential reporting risks</p> <p>Areas where data accuracy, completeness and consistency could be improved are highlighted.</p>
---	--	---



VERIFICATION REPORT

	the period? 4. How does management assess the internal control as reliable?	
--	--	--

Periodic Verification Protocol Table 4: Detailed audit testing of residual risk areas and random testing		
Areas of residual risks	Additional verification testing performed	Conclusions and Areas Requiring Improvement (including Forward Action Requests)
<p>List the residual areas of risks (Table 2 where detailed audit testing is necessary. In addition, other material areas may be selected for detailed audit testing.</p>	<p>The additional verification testing performed is described. Testing may include:</p> <ol style="list-style-type: none"> <li>1. Sample cross checking of manual transfers of data</li> <li>2. Recalculation</li> <li>3. Spreadsheet 'walk throughs' to check links and equations</li> <li>4. Inspection of calibration and maintenance records for key equipment                             <ul style="list-style-type: none"> <li>➤ Check sampling analysis results</li> <li>➤ Discussions with process engineers who have detailed knowledge of process uncertainty/error bands.</li> </ul> </li> </ol>	<p>Having investigated the residual risks, the conclusions should be noted here. Errors and uncertainties should be highlighted.</p> <p>Errors and uncertainty can be due to a number of reasons:</p> <ul style="list-style-type: none"> <li>➤ Calculation errors. These may be due to inaccurate manual transposition, use of inappropriate emission factors or assumptions etc.</li> <li>➤ Lack of clarity in the monitoring plan. This could lead to inconsistent approaches to calculations or scope of reported data.</li> <li>➤ Technological limitations. There may be inherent uncertainties (error bands) associated with the methods used to measure emissions e.g. use of particular equipment such as meters.</li> <li>➤ Lack of source data. Data for some sources may not be cost effective or practical to collect. This may result in the use of default data which has been derived based on certain assumptions/conditions and which will therefore have varying applicability in different situations.</li> </ul> <p>The second two categories are explored with the site personnel, based on their knowledge and experience of the processes. High risk process parameters or source data (i.e. those with a significant influence on the reported data, such as meters) are reviewed for these uncertainties.</p>



<b>Report clarifications and corrective action requests</b>	<b>Ref. to checklist question in tables 2/3</b>	<b>Summary of project owner response</b>	<b>Verification conclusion</b>
If the conclusions from the Verification are either a Corrective Action Request or a Clarification Request, these should be listed in this section.	Reference to the checklist question number in Tables 2, 3 and 4 where the Corrective Action Request or Clarification Request is explained.	The responses given by the Client or other project participants during the communications with the verification team should be summarized in this section.	This section should summarize the verification team's responses and final conclusions. The conclusions should also be included in Tables 2, 3 and 4, under "Final Conclusion".

**Figure 1 Verification protocol tables**

## 2.1 Review of Documents

The Monitoring Report (MR) version 2 submitted by "Rivneteploenergo", Ltd and additional background documents related to the project design and baseline, i.e. State Law, Project Design Document (PDD) version 08, Monitoring Plan, applied methodology, Kyoto Protocol, Clarifications on Verification Requirements were reviewed.

The verification findings presented in this report relate to the project as described in the PDD version 08 and Project Monitoring Report version 2 for the year 2008.

## 2.2 Follow-up Interviews

On 03/08/2009 Bureau Veritas Certification performed interviews with project stakeholders to confirm selected information and to resolve issues identified in the document review. Representatives of "Rivneteploenergo", Ltd were interviewed (see References). The main topics of the interviews are summarized in Table 1.

**Table 1 Interview topics**

<b>Interviewed organization</b>	<b>Interview topics</b>
"Rivneteploenergo", Ltd	Organizational structure. Responsibilities and authorities. Training of personnel. Quality management procedures and technology. Rehabilitation /Implementation of equipment (records). Metering equipment control.



	Metering record keeping system, database.
Consultant: Institute of Engineering Ecology	Baseline methodology. Monitoring plan. Monitoring report. Deviations from PDD.

### 2.3 Resolution of Clarification, Corrective and Forward Action Requests

The objective of this phase of the verification is to raise the requests for corrective actions and clarification and any other outstanding issues that needed to be clarified for Bureau Veritas Certification positive conclusion on the GHG emission reduction calculation.

Corrective Action Requests (CAR) are issued, where:

- i) there is a clear deviation concerning the implementation of the project as defined by the PDD;
- ii) requirements set by the MP or qualifications in a verification opinion have not been met; or
- iii) there is a risk that the project would not be able to deliver (high quality) CERs.

Forward Action Requests (FAR) are issued, where:

- iv) the actual status requires a special focus on this item for the next consecutive verification, or
- v) an adjustment of the MP is recommended.

The verification team may also use the term Clarification Request (CL), which would be where:

- vi) additional information is needed to fully clarify an issue.

To guarantee the transparency of the verification process, the concerns raised are documented in more detail in the verification protocol in Appendix A.

## 3 VERIFICATION FINDINGS

In the following sections, the findings of the verification are stated. The verification findings for each verification subject are presented as follows:

- 1) The findings from the desk review of the original project activity documents and the findings from interviews during the follow up visit are summarized. A more detailed record of these findings can be found in the Verification Protocol in Appendix A.
- 2) The conclusions for verification subject are presented.



The discussions and the conclusions that followed the preliminary verification report and possible corrective action requests are encapsulated in this section.

### 3.1 Remaining issues CAR's, FAR's from previous verification

One task of the verification is to check the remaining issues from the previous determination and verification or issues which are clearly defined for assessment in the PDD. The determination report, prepared by Bureau Veritas Certification Holding SAS notes following open issues.

#### **Corrective Action Request (CAR) 1**

There is no evidence of written project approval by the German side.

#### **Response**

Project is pending approval from the German side.

#### **Conclusion of the verification team**

Issue will be closed after report finalizing.

#### **Conclusion**

Issue is closed.

### 3.2 Project Implementation

#### 3.2.1 Discussion

According to valid legislation, all measuring equipment in Ukraine should meet the specified requirements of corresponding standards and is subject to the periodical verifying.

Type of Gas flue meters	Calibration interval
ЛГК-200 - produced by Ivano-Frankivsk plant JSC "Promprylad"	2 years
СПГ-741 (corrector) produced by "Lagika" Russia	2 years
«Універсал-02» (corrector) produced by "Grempis" Vinnytsa city	2 years
РГ-1000 produced by Ivano-Frankivsk plant JSC "Promprylad"	2 years
РГ-250 produced by Ivano-Frankivsk plant JSC "Promprylad"	2 years
ЛГК-80 produced by Ivano-Frankivsk plant JSC "Promprylad"	2 years
OE VPT (corrector) produced by Ivano-Frankivsk city Ltd. "Salut"	2 years

## VERIFICATION REPORT

ЛГК-150 produced by Ivano-Frankivsk plant JSC "Promprylad"	2 years
«Honivel» pressure meter produced in USA	3 years
B-25 (corrector) produced by "PIK" Donetsk city	2 years
ДИМС-25 produced by "Arsenal" plant. Kiev city	2 years
G-10 produced by Poland	2 years
<b>Electricity meters</b>	
EA05RAL, CA-I672, CA4-E5030, CP4-I673, CA4Y-I672, CP4Y-673, CA4E-5033, CA4Y-I672, EMS-112, CP4-5002	2 years

The control and monitoring system comes to fuel consumption measurement. Other parameters are defined by calculations or taken from statistic data. Fuel consumption measurement is realized at the Gas distributing units of the boiler-houses. Gas registration is caring out in volume units relate to standard conditions by means of automatic correction for temperature and pressure. The typical Gas distribution unit is shown at the fig. 1, typical Gas flow meter is shown at the fig. 2.



*Fig. 1. Gas distribution unit*

## VERIFICATION REPORT



*Fig. 2. Gas flow meter*

The typical scheme of the Gas distributing system is shown at the fig. 3. Usually it consists of the following equipment:

- Gas filter;
- Control and measuring devices for gas operation pressure measurement and control of pressure differential at the gas filter;
- Gas flue meter;
- stop valve;
- bypass facility.

## VERIFICATION REPORT

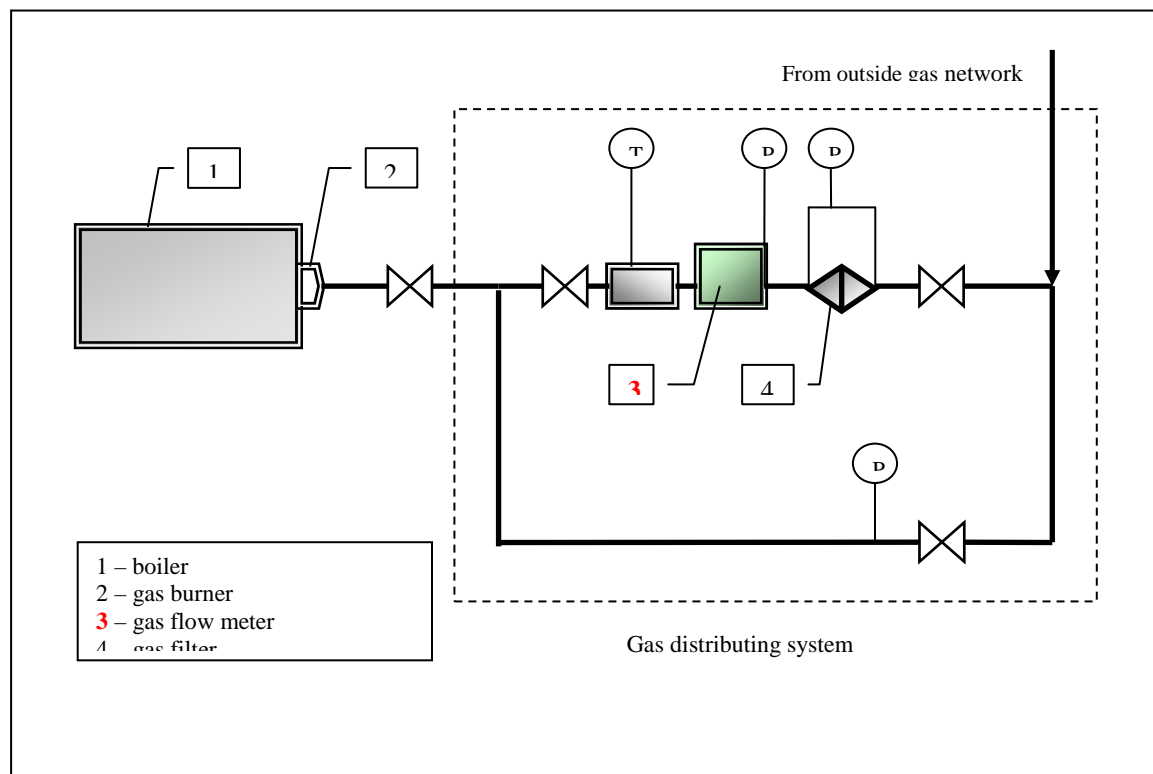

Fig. 3. Scheme of the Gas distribution system

Every hour operator of a boiler house read the values of inside air temperature, temperature of the natural gas and gas pressure at the entrance to the boiler-house. Natural gas consumption is measured by gas flow meters, installed at the every boiler-house. Every day operator of a boiler house make registration of daily gas consumption in the special paper journal.

T – inside air temperature and temperature of the natural gas;  
 P - gas pressure at the entrance to the boiler-house.

For gas consumption measurement the following Gas flue meters are used:

ЛГК-200 - produced by Ivano-Frankivsk plant JSC "Promprylad"  
 СПГ-741 (corrector) produced by "Lagika" Russia  
 «Універсал-02» (corrector) produced by "Grempis" Vinnytsa city  
 РГ-1000 produced by Ivano-Frankivsk plant JSC "Promprylad"  
 РГ-250 produced by Ivano-Frankivsk plant JSC "Promprylad"  
 ЛГК-80 produced by Ivano-Frankivsk plant JSC "Promprylad"  
 ОЕ VPT (corrector) produced by Ivano-Frankivsk city Ltd. "Salut"  
 ЛГК-150 produced by Ivano-Frankivsk plant JSC "Promprylad"  
 «Honivel» pressure meter produced in USA  
 В-25 (corrector) produced by "PIK" Donetsk city  
 ДІМС-25 produced by "Arsenal" plant. Kiev city  
 G-10 produced by Poland





## VERIFICATION REPORT

For power consumption measurement the following electricity meters are used:

EA05RAL, CA-I672, CA4-E5030, CP4-I673, CA4Y-I672, CP4Y-673, CA4E-5033, CA4Y-I672, EMS-112, CP4-5002.

According to valid legislation, all measuring equipment in Ukraine should meet the specified requirements of corresponding standards and is subject to the periodical verifying.

Type of Gas flue meters	Calibration interval
ЛГК-200 - produced by Ivano-Frankivsk plant JSC "Promprylad"	2 years
СПГ-741 (corrector) produced by "Lagika" Russia	2 years
«Універсал-02» (corrector) produced by "Grempis" Vinnytsa city	2 years
РГ-1000 produced by Ivano-Frankivsk plant JSC "Promprylad"	2 years
РГ-250 produced by Ivano-Frankivsk plant JSC "Promprylad"	2 years
ЛГК-80 produced by Ivano-Frankivsk plant JSC "Promprylad"	2 years
OE VPT (corrector) produced by Ivano-Frankivsk city Ltd. "Salut"	2 years
ЛГК-150 produced by Ivano-Frankivsk plant JSC "Promprylad"	2 years
«Honivel» pressure meter produced in USA	3 years
B-25 (corrector) produced by "PIK" Donetsk city	2 years
ДІМС-25 produced by "Arsenal" plant. Kiev city	2 years
G-10 produced by Poland	2 years
<b>Electricity meters</b>	
EA05RAL, CA-I672, CA4-E5030, CP4-I673, CA4Y-I672, CP4Y-673, CA4E-5033, CA4Y-I672, EMS-112, CP4-5002	2 years

### 3.2.2 Findings

None.

### 3.2.3 Conclusion



The project complies with the JI requirements as well as with the local requirements.

### 3.3 Internal and External Data

#### 3.3.1 Discussion

19 parameters are monitored within the projects but only three of them (volume of natural gas consumption, produced electricity for the new cogeneration plants and electricity consumed) is measured directly. The remaining monitoring parameters used in calculation of the baseline and project line emissions are taken as statistic data.

The following parameters need to be obtained according to the monitoring plan:

1. Natural gas, coal, fuel oil and wood chips consumption at boiler houses (for natural gas - m<sup>3</sup>, for coal, fuel oil and wood chips – ton, manually recorded every day).
2. Average annual heating value of natural gas, coal, fuel oil, wood chips (MJ/m<sup>3</sup>, for natural gas - data is provided by natural gas suppliers usually 3 times per month, for coal, fuel oil, wood chips - quality certificate is given by coal supplier's for every consignment)
3. Average daily outside temperature during the heating season (°C), recorded once per heating season. Daily temperature is registered every day of heating season
4. Average inside temperature during the heating season (°C), recorded once per heating season)
5. Number of Customers (Customers update the contracts for hot water supply service with balance-owners (ZhEK) once per year. ZhEK give to "Rivneteploenergo", Ltd, ME RCC „Teplotransservise" and other enterprises personal accounts of customers once per month. Contracts with organizations and legal entities are concludes directly with with "Rivneteploenergo", Ltd., ME RCC „Teplotransservise" and other enterprises they are updated once per year)
6. Heating area (total, m<sup>2</sup> the information is collected at the sales departments of district heating productive units of "Rivneteploenergo", Ltd., ME RCC „Teplotransservise" and other enterprises by the certificates of owners in accordance with technical passport of building. Total area with balconies and stairs and Heating area are displayed in the special journal.)
7. Heat transfer factor of buildings (W/m<sup>2</sup>\*K, Heat transfer factor is recorded ones per year at recording of connection or disconnection of any heating area to boiler-houses included in project)



8. Heating area of buildings (previously existed in the base year) with the renewed (improved) thermal insulation in the reported year ( $m^2$ , once per year)
9. Heating area of newly connected buildings (assumed with the new (improved) thermal insulation) in the reported year ( $m^2$ , once per year)
10. Heat transfer factor of buildings with the new thermal insulation ( $W/m^2 \cdot K$ )
11. Duration of the heating period (hours, once per year)
12. Duration of the hot water supply period (hours, once per day)
13. Maximum connected load to the boiler-house, that is required for heating (MW, once per year)
14. Connected load to the boiler-house, that is required for hot water supply service (MW, once per year)
15. Standard specific discharge of hot water per personal account ( $kWh/h$ , once per year)
16. Carbon emission factor (for natural gas  $kt CO_2/TJ$ , once per year)
17. Recalculating factor for average load during heating period (once per year)
18. Electric power generation (MWh, manually recorded every day)
19. Electric power consumption (MWh, manually recorded every day)

The records are maintained on daily and annually basis, the boiler operation is statutory, so the chances of misstatement in the records are hereby low.

### 3.3.2 Findings

None.

### 3.3.3 Conclusion

The project complies with the requirements.

## 3.4 Environmental and Social Indicators

### 3.4.1 Discussion

No environmental and social indicators are defined in the monitoring plan. At the same time implementation of project "District Heating System Rehabilitation in Rivne Region" has a positive effect on environment. Following points give detailed information on environmental benefits.

VERIFICATION REPORT

---

1. Project implementation will allow to save more than 2557 thousand tons of natural gas per year, 2169 ton of fuel oil and 638 ton of coal. Natural gas, fuel oil and coal are a non-renewable resources and its economy is important.

2. Due to fuel economy and new environmentally friendlier technologies of fuel combustion, project implementation reduced emissions of SO<sub>x</sub>, NO<sub>x</sub>, CO and particulate matter (co-products of combustion).

There are no negative social impacts associated with the project.

### 3.4.2 Findings

None

### 3.4.3. Conclusion

The project complies with the JI requirements as well as with the local requirements.

## 3.5 Management and Operational System

### 3.5.1 Discussion

In order to ensure a successful operation of a Client project and the credibility and verifiability of the emissions reductions achieved, the project must have a well defined management and operational system.

The “Rivneteploenergo”, Ltd complies with all legal and statutory requirements of the Ukrainian Government and the same were made available to the verification team. Appropriate procedures reflect commitment in management and operational control. Job descriptions, technological instructions are in place. Calibration and maintenance procedures are followed according statutory requirements of Ukraine.

### 3.5.2 Findings

None

### 3.5.3 Conclusion

The Monitoring Report and the Management and Operational Systems are eligible for reliable project monitoring.



## 4 SECOND PERIODIC VERIFICATION FINDINGS

### 4.1 Completeness of Monitoring

#### 4.1.1 Discussion

The reporting procedures reflect the monitoring plan completely. It is confirmed that the monitoring report does comply with the monitoring methodology and PDD.

All parameters were determined as prescribed. The complete data is stored electronically and documented. The necessary procedures have been defined in internal procedures.

According to PDD version 0.8, emission reductions during 2008 monitoring period were expected to be 36869,6t CO<sub>2</sub>e. According to Monitoring Report version 02 emission reductions achieved are 45248t CO<sub>2</sub>e.

#### 4.1.2 Findings

##### Clarification Request (CL) 1

Please, clarify the difference between emission reductions achieved and stated in the MR version 02 and the ones calculated in the PDD.

##### **Response**

GH gas emission reduction, that was planned in PDD for 2004, was not achieved because it became necessary more long debugging of launched turbines. Moreover, there was not completely implemented parts of network that connected boiler-house Knyazya Volodymyra, 71 and to area "Pivnichniy", and used to supply hot water to population of this area.

	By monitoring	By PDD
2004	401	20541
2005	24594	22584
2006	39286	27429
2007	39790	29471
2008	45248	36870

Formulae presented in D.1.4. are used to estimate emission reductions in PDD. These calculations were based on equipment efficiency increasing. In the PDD calculations, by the conservatism principle, the minimal guaranteed effects from all energy saving measures were taken into account.

Also, emission reductions from implemented measures were calculated only for the next years after energy saving measures implementation. In fact result in the form of emissions reduction is achieved immediately after energy saving measures implementation in the year of reconstruction, especially if it was done at the beginning of the year.



Expressly to calculate all emissions reduction from the project, “SVT e.V.” (Germany) and Institute of Engineering Ecology invented monitoring methodology for “District Heating” projects in Ukrainian conditions that take into account all measures involved in the project and it’s peculiarities This methodology is presented in section D (monitoring plan).

It is based on the permanent measuring of the fuel consumption and corrections for possible changes of parameters in reporting year comparing to the baseline. The changeable parameters may be the lower heating value of fuels, quality of heating service (providing of normative temperature value inside apartments), weather features, number of customers, etc. As it was mentioned before, this approach eliminates any possibility of reduction of fuel consumption and correspondingly GHG emission due to incomplete delivery of heat to consumers

Calculations of emissions reduction in Monitoring Report for 2004-2007 and Monitoring Report for 2008 were prepared in accordance with this methodology.

## **Conclusion of verification team**

### **4.1.3 Conclusion**

Issue is closed.

## **4.2 Accuracy of Emission Reduction Calculations**

### **4.2.1 Discussion**

The audit team confirms that emission reduction calculations have been performed according to the Monitoring Plan.

According to the Article 10 paragraph 1 of the Ukrainian Law “On Metrology and Metrological Activity” measurement results can be used in case if appropriate characteristics of errors and uncertainty are known. Characteristics of errors are presented in the passports of the equipment. Project consists of the 29 project and 41 baseline parameters that are being monitored. Some of the parameters that are used in the calculation of the baseline and project emissions are measured directly with the use of special equipment while others are estimated with the use of appropriate coefficients.

### **4.2.2 Findings**

#### **Clarification Request (CL) 2**

Please provide information on how the level of uncertainty is taken into account. And please define if the level of uncertainty is taken into account in the final emission reductions calculations.



## Response

According to the certification system, meter measures within the error guaranteed by the manufacturer. Value of the error as small as his accuracy is 0.5%, so we do not take it into consideration.

### Conclusion of verification team

Issue is closed.

#### 4.2.3 Conclusion

Issue is closed.

### 4.3 Quality Evidence to Determine Emissions Reductions

#### 4.3.1 Discussion

Concerning verification the calculation of emission reductions is based on internal data. The origin of those data was explicitly checked. Further on, entering and processing of those data in the monitoring workbook Excel sheet was checked where predefined algorithms compute the annual value of the emission reductions. All equations and algorithms used in the different workbook sheets were checked. Inspection of calibration and maintenance records for key equipment was performed for all relevant meters.

Necessary procedures have been defined in internal procedures and additional internal documents relevant for the determination of the various parameters on daily basis.

#### 4.3.2 Findings

None

#### 4.3.3 Conclusion

The project complies with the requirements.

### 4.4 Management System and Quality Assurance

#### 4.4.1 Discussion

The director of "Rivneteploenergo", Ltd., Mr. Stepan Koropetskiy appointed the responsible person, Mrs. Tetiana Kazachek, for the implementation and management of the monitoring process at the "Rivneteploenergo", Ltd.. Mrs. Tetiana Kazachek is responsible for supervising of data collection, measurements, calibration, data recording and storage. The director of ME RCC „Teplotranssservise”, Mr. Petro Sergiychuk, appointed the responsible person, Mrs. Oksana Trush, for the implementation and management of the monitoring process at the ME

RCC „Teplotranssservise”.

Dr. Dmitri Paderno, vice director of Institute of Engineering Ecology, is responsible for baseline and monitoring methodology development.

Ms. Tetiana Grechko, senior engineer of Institute of Engineering Ecology, is responsible for baseline and monitoring methodology development and data processing.

As far as the main activity of “Rivneteploenergo”, Ltd., ME RCC „Teplotranssservise” and other enterprises will not change in course of the JI project implementation, the special technical trainings for personnel are not necessary. The technical personnel of the enterprise has sufficient knowledge and experience for implementation of the project activity and maintenance of the usual equipment.

In cases of the new (never used at this enterprise before at the enterprise), equipment installation, the company - producer of this equipment should provide trainings for personnel.

“Rivneteploenergo”, Ltd., ME RCC „Teplotranssservise” and other enterprises provides personnel retraining according to protection of labour norms. The enterprise has the Labour protection department, which is responsible for raising the level of personnel skills and trainings.

In course of the JI project development (starting from 2004), specialists of Institute of Engineering Ecology and then also of the European Institute for safety, security, insurance and environmental technics carried out a comprehensive consultations and trainings for involved representatives of ME RCC „Teplotranssservise” on the necessary data collection according to Monitoring plan for the project.

The special training was hold in January 2009.

The special group was organized consisted of representatives of ME RCC „Teplotranssservise”, ME RCC “Komunenergiya” and Institute of Engineering Ecology, in particular:

Petro Sergiychuk - ME RCC „Teplotranssservise”, Director;

Oksana Trush - ME RCC „Teplotranssservise”, Coordinator of projects with foreign investments;

Volodymyr Novozhilov - ME RCC “Komunenergiya”, Acting Director;

Ludmyla Danyluk - ME RCC “Komunenergiya”, Chief of PTD;

Natalya Rachinska - ME RCC „Teplotranssservise”, Chief of PTD;

Tetiana Grechko - Institute of Engineering Ecology, senior engineer;

Dmitri Paderno - Institute of Engineering Ecology, vice director.

The responsible stuff of the Production-Technical Service of “Rivneteploenergo”, Ltd., ME RCC „Teplotranssservise” and other enterprises is involved in this process.

#### 4.4.2 Findings

None

#### 4.4.3 Conclusion

The project complies with the requirements.



## 5 PROJECT SCORECARD

Risk Areas		Conclusions			Summary of findings and comments
		Baseline Emissions	Project Emissions	Calculated Emission Reductions	
<b>Completeness</b>	Source coverage/ boundary definition	✓	✓	✓	All relevant sources are covered by the monitoring plan and the boundaries of the project are defined correctly and transparently.
<b>Accuracy</b>	Physical Measurement and Analysis	✓	✓	✓	State-of-the-art technology is applied in an appropriate manner. Appropriate backup solutions are provided.
	Data calculations	✓	✓	✓	Emission reductions are calculated correctly
	Data management & reporting	✓	✓	✓	Data management and reporting were found to be satisfying.
<b>Consistency</b>	Changes in the project	✓	✓	✓	Results are consistent to underlying raw data.

## 6 SECOND VERIFICATION STATEMENT

Bureau Veritas Certification has performed a verification of the JI project “District Heating System Rehabilitation in Rivne Region”. The verification is based on the currently valid documentation of the United Nations Framework Convention on the Climate Change (UNFCCC).

The management of the “Rivneteploenergo”, Ltd is responsible for the preparation of the GHG emissions data and the reported GHG emissions reductions of the project on the basis set out within the project Monitoring and Verification Plan indicated in the final PDD version 08. The development and maintenance of records and reporting procedures in accordance with that plan, including the calculation and determination of GHG emission reductions from the project is the responsibility of the management of the project.

Bureau Veritas Certification verified the Project Monitoring Report version 02 for the reporting period as indicated below. Bureau Veritas Certification confirms that the project is implemented as described in validated project design documents. Installed equipment being essential for generating emission reduction runs reliably and is calibrated appropriately. The monitoring system is in place and the project is ready to generate GHG emission reductions.

VERIFICATION REPORT

---

Bureau Veritas Certification can confirm that the GHG emission reduction is calculated without material misstatements. Our opinion relates to the project's GHG emissions and resulting GHG emissions reductions reported and related to the valid project baseline and monitoring, and its associated documents. Based on the information we have seen and evaluated we confirm the following statement:

Reporting period: From 01/01/2008 to 31/12/2008

Baseline emissions : 152280 t CO2 equivalents.  
Project emissions : 197528 t CO2 equivalents.  
Emission Reductions : 45248 t CO2 equivalents.

## 7 REFERENCES

### Category 1 Documents:

Documents provided that relate directly to the GHG components of the project.

- /1/ Project Design Document, version 08, dated 30 of November 2008
- /2/ Monitoring Report version 02 , dated 18 of December 2009
- /3/ Determination Report by the Bureau Veritas Certification Holding SAS, dated 07 of December 2009

### Category 2 Documents:

Documents checked during the verification onsite are presented in Annex C.

### Persons interviewed:

List of persons interviewed during the verification or persons that contributed with other information that are not included in the documents listed above.

- /1/ Serhij Paladiychuk - chairman of the Rivne representative office of civil society development Fund
- /2/ Mykola Tarasyuk - chairman of standing committee on municipal economy, ecology, transport and connection questions; chief ZHKP «Western»
- /3/ Deputy of Rivne city advice Ivan Turko - national deputy; a representative of Ukrainian national party in Rivne
- /4/ Dubrovin A.V. - chief of changing
- /5/ Vorobey O.A. - operator
- /6/ Goloyug G.O. - operator



- /7/ Veremchuk U.D. - chief of area #2
- /8/ Zhavoronkov V.U. - chief engineer of area #2
- /9/ Kursik O.A. - watchman
- /10/ Kapac L.L. - operator
- /11/ Semenchuk N.O. - operator
- /12/ Semenov A.L. - chief of area #1
- /13/ Torubko V.T. - chief engineer of area #1
- /14/ Dib'yak V.E. - chief of area #9
- /15/ Yuschuk O.V. - chief engineer of area #9
- /16/ Timoschuk M.O. – watchman
- /17/ Zakharov V.I. – chief area #3
- /18/ Kravchuk V.P. – engineer of area #3
- /19/ Parchuk G.M. – operator of boiler room
- /20/ Lukashova M.V. – watchman
- /21/ Endrushak V.V. – chief of boiler room
- /22/ Pereverzev S.V. – engineer
- /23/ Sasko L.F. – watchman
- /24/ Kolodiy S.A. – chief of area #8
- /25/ Nevinniy V.V. - chief engineer of area #8
- /26/ Voycovich N.A. - operator

- o0o -



## APPENDIX A: COMPANY JI PROJECT VERIFICATION PROTOCOL

Initial Verification Protocol Table 1

Objective	Reference	Comments	Conclusion (CARs/FARs)
<b>1. Opening Session</b>			
<b>1.1. Introduction to audits</b>	/2/	<p>The intention and the target of the audit were illustrated to the participants of the audit. Participants at the audit were the following persons: Verification team: Mrs. Nadiia Kaiun, Lead Auditor, Bureau Veritas Ukraine, Mrs. Kateryna Zinevych, Auditor, Bureau Veritas Ukraine, Mrs. Iuliia Gumeniuk, specialist, Bureau Veritas Ukraine.</p> <p>Interviewed persons: “Rivneteploenergo”, Ltd and Institute of Engineering Ecology: The director of “Rivneteploenergo”, Ltd., Mr. Stepan Koropetskiy appointed the responsible person, Mrs. Tetiana Kazachek, for the implementation and management of the monitoring process at the “Rivneteploenergo”, Ltd.. Mrs. Tetiana Kazachek is responsible for supervising of data collection, measurements, calibration, data recording and storage. The director of ME RCC „Teplotransservise”, Mr. Petro Sergiychuk, appointed the responsible person, Mrs. Oksana Trush, for the implementation and management of</p>	<b>OK</b>



**BUREAU  
VERITAS**

## VERIFICATION REPORT

Objective	Reference	Comments	Conclusion (CARs/FARs)
		<p>the monitoring process at the ME RCC „Teplotransservise”. Institute of Engineering Ecology: Dr. Dmitri Paderno, vice director of Institute of Engineering Ecology, is responsible for baseline and monitoring methodology development. Ms. Tetiana Grechko, senior engineer of Institute of Engineering Ecology, is responsible for baseline and monitoring methodology development and data processing.</p> <p>Dr. Dmitri Paderno, vice director of Institute of Engineering Ecology, is responsible for baseline and monitoring methodology development. Ms. Tetiana Grechko, senior engineer of Institute of Engineering Ecology, is responsible for baseline and monitoring methodology development and data processing.</p>	
<b>1.2. Clarification of access to data archives, records, plans, drawings etc.</b>	/2/	The verification team got open access to all required plans, data, records, drawings and to all relevant facilities.	<b>OK</b>
<b>1.3. Contractors for equipment and installation works</b>	/2/	Project has been implemented as defined in the PDD and the implementation is evidenced by statements of work completion.	<b>OK</b>
<b>1.4. Actual status of installation works</b>	/2/	Implementation of boiler houses rehabilitation and network rehabilitation is realized according to the project plan. There are no deviations or revisions to the registered monitoring plan.	<b>OK</b>



**BUREAU  
VERITAS**

## VERIFICATION REPORT

Objective	Reference	Comments	Conclusion (CARs/FARs)
<b>2. Open issues indicated in validation report</b>			
<b>2.1. Missing steps to final approval</b>	/2/	<p>There is no evidence of written project approvals by the Parties involved. There is no Letter of Approval from National Agency of Ecological Investments.</p> <p><u>Corrective Action Request (CAR) 1</u> There is no evidence of written project approvals by the German side.</p>	<b>CAR1</b>
<b>3. Implementation of the project</b>			
<b>3.1. Physical components</b>	/2/	<p>All the measures envisaged by Project Plan are implemented.</p> <p>Reduction of fuel consumption is based on increase of the boiler efficiencies, reduction of heat losses in networks, CHP and frequency controllers installation. The following activities ensure fuel saving:</p> <ul style="list-style-type: none"> <li>- Replacement of old boilers by new highly efficient boilers;</li> <li>- Upgrading of boilers' burners;</li> <li>- Fuel switch from coal and fuel oil to natural gas;</li> <li>- Improving of the network organization, application of the new insulation and the pre-insulated pipes;</li> <li>- Installation of CHP;</li> <li>- Installation of frequency controllers at smoke exhauster and hot</li> </ul>	<b>OK</b>



BUREAU  
VERITAS

## VERIFICATION REPORT

Objective	Reference	Comments	Conclusion (CARs/FARs)
		<p>water pumps engines.</p> <ul style="list-style-type: none"> <li>- Installation of air heaters;</li> <li>- Partial replacement of fossil fuel by the renewable sources of fuel such as wood and wood chips (expansion of this tendency).</li> </ul>	
<b>3.2. Project boundaries</b>	/1/	Yes, the project boundaries are as defined in the PDD.	<b>OK</b>
<b>3.3. Emission reductions achieved</b>	/2/	<p>According to PDD version 0.8, emission reductions during 2008 monitoring period were expected to be 36869,6t CO<sub>2</sub>e. According to Monitoring Report version 1.11 emission reductions achieved are 45248t CO<sub>2</sub>e.</p> <p><u>Clarification Request (CL) 1</u> Please, clarify the difference between emission reductions achieved and stated in the MR version 02 and the ones calculated in the PDD.</p>	<b>CL1</b>
<b>3.4. Monitoring and metering systems</b>	/2/	<p>The installations have the metering and measurement devices such as gas flow meters, electric power consumption meters to monitor parameters related to project. All equipments are of reputed make and included in the structured calibration plans where they are periodically calibrated. The procedures have been documented for the equipment operation.</p> <p>The control and monitoring system comes to fuel consumption measurement. Fuel consumption measurement is realized at the Gas distributing units of the boiler-houses. The Gas distributing system consists of the following equipment:</p> <ul style="list-style-type: none"> <li>• Gas filter;</li> </ul>	<b>OK</b>



BUREAU  
VERITAS

## VERIFICATION REPORT

Objective	Reference	Comments	Conclusion (CARs/FARs)
		<ul style="list-style-type: none"> <li>• Control and measuring devices for gas operation pressure measurement and control of pressure differential at the gas filter;</li> <li>• Gas flue meter;</li> <li>• stop valve;</li> <li>• bypass facility.</li> </ul>	
<b>3.5. Data uncertainty</b>	/2/	<p>Project consists of the 19 parameters that are being monitored. Some of the parameters that are used in the calculation of the baseline and project emissions are measured directly with the use of special equipment while others are estimated with the use of appropriate coefficients. Characteristics of errors are presented in the passports of the equipment.</p> <p>But there is no information on how the level of uncertainty is taken into account in the final emission reductions calculations.</p> <p><u>Clarification Request (CL) 2</u> Please provide information on how the level of uncertainty is taken into account. And please define if the level of uncertainty is taken into account in the final emission reductions calculations.</p>	<b>CL2</b>





## VERIFICATION REPORT

Objective	Reference	Comments	Conclusion (CARs/FARs)
<b>3.6. Calibration and quality assurance</b>	/2/	<p>All monitoring equipment is part of detailed calibration plan. The strict control is maintained over the calibration process.</p> <p>The technical personnel of Rivneteploenergo”, Ltd., ME RCC „Teplotransservise” and other enterprises have sufficient knowledge and experience for implementation of the project activity and maintenance of the usual equipment. In cases of the new (never used at this enterprise before at the enterprise), equipment installation, the company - producer of this equipment should provide trainings for personnel.</p> <p>“Rivneteploenergo”, Ltd., ME RCC „Teplotransservise” and other enterprises provides personnel retraining according to protection of labour norms. The enterprise has the Labour protection department, which is responsible for raising the level of personnel skills and trainings.</p>	<b>OK</b>
<b>3.7. Data acquisition and data processing systems</b>	/2/	<p>Registration of Natural gas consumption at boiler houses of Measured by “Rivneteploenergo”, Ltd., ME RCC „Teplotransservise” and other enterprises involved in the project is carried out by the following scheme:</p> <ol style="list-style-type: none"> <li>1. All boiler-houses are equipped with gas flow meters.</li> <li>2. Operators of all boiler-houses register the instrument readings in the paper journals “Journal of registration of boiler-house’s operation parameters” every day.</li> <li>3. At the boiler-houses that are not equipped with gas</li> </ol>	<b>OK</b>



**BUREAU  
VERITAS**

## VERIFICATION REPORT

Objective	Reference	Comments	Conclusion (CARs/FARs)
		<p>volume correctors , operators register parameters of gas: temperature and pressure in these journals every 2 hours. These parameters are used to bring gas consumption to normal conditions, see Fig.4.</p> <p>4. Every day operators transfer values of gas consumption to dispatchers of the corresponding enterprises: "Rivneteploenergo", Ltd, ME RCC „Teplotransservise”, ME RCC “Komunenergiya”, ME “ZdolbunivKomunenergiya” of Zdolbuniv City Council and ME “Teploservis” of Dubrovitsa Regional Council by phone. Monthly they transfer the paper report. Data are storing in the Production-Technical departments (PTD) and used for payments with gas suppliers.</p>	
<b>3.8. Reporting procedures</b>	/2/	The Monitoring Plan defines the responsibilities to consolidate the data required for emission reduction calculations. Calculations are transparent and restricted to entering annually the production data into a predefined Excel spreadsheet.	<b>OK</b>
<b>3.9. Documented instructions</b>	/2/	Section B.3. Data processing and archiving (including software used) of the Monitoring Report version 2 provides with the necessary information relating the procedures for the monitoring, measurements and reporting. These were verified onsite and found satisfactory.	<b>OK</b>

**BUREAU  
VERITAS**

## VERIFICATION REPORT

Objective	Reference	Comments	Conclusion (CARs/FARs)
<b>3.10. Qualification and training</b>	/2/	<p>The director of “Rivneteploenergo”, Ltd., Mr. Stepan Koropetskiy appointed the responsible person, Mrs. Tetiana Kazachek, for the implementation and management of the monitoring process at the “Rivneteploenergo”, Ltd.. Mrs. Tetiana Kazachek is responsible for supervising of data collection, measurements, calibration, data recording and storage. The director of ME RCC „Teplotranssservise”, Mr. Petro Sergiychuk, appointed the responsible person, Mrs. Oksana Trush, for the implementation and management of the monitoring process at the ME RCC „Teplotranssservise”.</p> <p>Dr. Dmitri Paderno, vice director of Institute of Engineering Ecology, is responsible for baseline and monitoring methodology development.</p> <p>Ms. Tetiana Grechko, senior engineer of Institute of Engineering Ecology, is responsible for baseline and monitoring methodology development and data processing.</p>	<b>OK</b>
<b>3.11. Responsibilities</b>	/2/	<p>The director of “Rivneteploenergo”, Ltd., Mr. Stepan Koropetskiy appointed the responsible person, Mrs. Tetiana Kazachek, for the implementation and management of the monitoring process at the “Rivneteploenergo”, Ltd.. Mrs. Tetiana Kazachek is responsible for supervising of data collection, measurements, calibration, data recording and storage. The director of ME RCC „Teplotranssservise”, Mr. Petro Sergiychuk, appointed the responsible person, Mrs. Oksana Trush, for the implementation and management of the monitoring process at the ME RCC „Teplotranssservise”.</p>	<b>OK</b>



## VERIFICATION REPORT

Objective	Reference	Comments	Conclusion (CARs/FARs)
		<p>Dr. Dmitri Paderno, vice director of Institute of Engineering Ecology, is responsible for baseline and monitoring methodology development.</p> <p>Ms. Tetiana Grechko, senior engineer of Institute of Engineering Ecology, is responsible for baseline and monitoring methodology development and data processing.</p> <p>The responsibilities and authorities are described for each individual in job descriptions as required statutorily.</p>	
<b>3.12. Troubleshooting procedures</b>	/2/	Any problem occurring that concerns this project is to be reported immediately to the project manager, who takes the appropriate measures.	<b>OK</b>
<b>4. Internal Data</b>			
<b>4.1. Type and sources of internal data</b>	/2/	The internal parameters are obtained according to the monitoring plan: Monitoring report, Annex1 contains internal parameters that are monitored.	<b>OK</b>
<b>4.2. Data collection</b>	/2/	The responsibility for data collection is described in the monitoring plan. Natural gas consumption at boiler houses of "Rivneteploenergo", Ltd was carried in the following way: Every hour operator of a boiler house read the values of inside air temperature, temperature of the natural gas and gas pressure at the entrance to the boiler-house. Natural gas consumption is measured by gas flow meters, installed at the every boiler-house. Every day operator of a boiler	<b>OK</b>



## VERIFICATION REPORT

Objective	Reference	Comments	Conclusion (CARs/FARs)
		house make registration of daily gas consumption in the special paper journal.	
<b>4.3. Quality assurance</b>	/2/	Section B.3. Data processing and archiving (including software used) of the Monitoring Report version 2 provides with the necessary information relating the procedures for the monitoring, measurements and reporting. These were verified onsite and found satisfactory.	<b>OK</b>
<b>4.4. Significance and reporting risks</b>	/2/	As the records are maintained on daily basis and the consumption natural gas is a statutory records the chances of misstatement are hereby low.	<b>OK</b>
<b>5. External Data</b>			
<b>5.1. Type and sources of external data</b>	/2/	The used external data: • Carbon emission factor – IPCC values are used. The external parameters are obtained according to the monitoring plan.	<b>OK</b>
<b>5.2. Access to external data</b>	/2/	Origin of the external data is indicated in the monitoring report, Annex2.	<b>OK</b>
<b>5.3. Quality assurance</b>	/2/	See chapter 5.1..	<b>OK</b>
<b>5.4. Data uncertainty</b>	/2/	See chapter 5.1.	<b>OK</b>

**BUREAU  
VERITAS**

## VERIFICATION REPORT

Objective	Reference	Comments	Conclusion (CARs/FARs)
<b>5.5. Emergency procedures</b>	/2/	See chapter 5.1.	<b>OK</b>
<b>6. Environmental and Social Indicators</b>			
<b>6.1. Implementation of measures</b>	/2/	<p>No environmental and social indicators are defined in the monitoring plan. At the same time implementation of project “District Heating System Rehabilitation in Rivne Region” has a positive effect on environment. Following points give detailed information on environmental benefits.</p> <p>1. Project implementation will allow to save more than 2557 thousand tons of natural gas per year, 2169 ton of fuel oil and 638 ton of coal. Natural gas, fuel oil and coal are a non-renewable resources and its economy is important.</p> <p>2. Due to fuel economy and new environmentally friendlier technologies of fuel combustion, project implementation reduced emissions of SO<sub>x</sub>, NO<sub>x</sub>, CO and particulate matter (co-products of combustion).</p> <p>There are no negative social impacts associated with the project.</p>	<b>OK</b>
<b>6.2. Monitoring equipment</b>	/2/	See chapter 6.1.	<b>OK</b>
<b>6.3. Quality assurance procedures</b>	/2/	See chapter 6.1.	<b>OK</b>
<b>6.4. External data</b>	/2/	See chapter 6.1.	<b>OK</b>

**BUREAU  
VERITAS**

## VERIFICATION REPORT

Objective	Reference	Comments	Conclusion (CARs/FARs)
<b>7. Management and Operational System</b>			
<b>7.1. Documentation</b>	/2/	<p>The company complies with all legal and statutory requirements of the Ukraine and the same were made available to the verification team.</p> <p>“Rivneteploenergo”, Ltd has all the necessary permissions and licenses, issued by the State Inspection on Labor Safety, that allow performing of the following activities: to perform building and installation works; to perform designing works; to conduct adjustment and alignment of fuel-using equipment etc.</p>	<b>OK</b>
<b>7.2. Qualification and training</b>	/2/	<p>“Rivneteploenergo”, Ltd., ME RCC „Teplotransservise” and other enterprises provides personnel retraining according to protection of labour norms. The enterprise has the Labour protection department, which is responsible for raising the level of personnel skills and trainings.</p> <p>In course of the JI project development (starting from 2004), specialists of Institute of Engineering Ecology and then also of the European Institute for safety, security, insurance and environmental technics carried out a comprehensive consultations and trainings for involved representatives of ME RCC „Teplotransservise” on the necessary data collection according to Monitoring plan for the project.</p> <p>The responsibilities and authorities are described for each individual in job descriptions as required statutorily.</p>	<b>OK</b>



**BUREAU  
VERITAS**

## VERIFICATION REPORT

Objective	Reference	Comments	Conclusion (CARs/FARs)
<b>7.3. Allocation of responsibilities</b>	/2/	The responsibilities and authorities are described for each individual in job descriptions as required statutorily. Persons working at sites are aware of their responsibilities, and relative records are maintained.	<b>OK</b>
<b>7.4. Emergency procedures</b>	/2/	The emergency procedures with respect to operation controls are available in data control.	<b>OK</b>
<b>7.5. Data archiving</b>	/2/	Data are archived in the physical and electronic forms and then stored electronically.	<b>OK</b>
<b>7.6. Monitoring report</b>	/2/	Calculations are laid down in the monitoring report.	<b>OK</b>
<b>7.7. Internal audits and management review</b>	/2/	In the Section C.3 of the Monitoring Report version 02 internal audits and control measures are performed. Measurement equipment calibration was carried out by Ivano-Frankivsk city JSC "Promprylad", Ltd. "Rivnegaz", Ltd. "Dobrobut" t. Kvasyliv, Derzhstandartmetrologiya of Rivne city, "Grempis" Vinnytsa city, "Apater" Poland.	<b>OK</b>





## VERIFICATION REPORT

<b>Periodic Verification Checklist Protocol Table 2: Data Management System/Controls</b>		
<b>Identification of potential reporting risk</b>	<b>Identification, assessment and testing of management controls</b>	<b>Areas of residual risks</b>
<b>1. Defined organizational structure, responsibilities and competencies</b>		
<b>1.1. Position and roles</b>	Full	The director of "Rivneteploenergo", Ltd., Mr. Stepan Koropetskiy appointed the responsible person, Mrs. Tetiana Kazachek, for the implementation and management of the monitoring process at the "Rivneteploenergo", Ltd. Mrs. Tetiana Kazachek is responsible for supervising of data collection, measurements, calibration, data recording and storage. The director of ME RCC „Teplotranssservice”, Mr. Petro Sergiychuk, appointed the responsible person, Mrs. Oksana Trush, for the implementation and management of the monitoring process at the ME RCC „Teplotranssservice”.
<b>1.2. Responsibilities</b>	Full	The director of "Rivneteploenergo", Ltd., Mr. Stepan Koropetskiy appointed the responsible person, Mrs. Tetiana Kazachek, for the implementation and management of the monitoring process at the "Rivneteploenergo", Ltd. Mrs. Tetiana Kazachek is responsible for supervising of data collection, measurements, calibration, data recording and storage. The director of ME RCC „Teplotranssservice”, Mr. Petro Sergiychuk, appointed the responsible person, Mrs. Oksana Trush, for the implementation and management of the monitoring process at the ME RCC „Teplotranssservice”.



## VERIFICATION REPORT

		<p>Dr. Dmitri Paderno, vice director of Institute of Engineering Ecology, is responsible for baseline and monitoring methodology development.</p> <p>Ms. Tetiana Grechko, senior engineer of Institute of Engineering Ecology, is responsible for baseline and monitoring methodology development and data processing.</p>
<b>1.3. Competencies needed</b>	Full	<p>The overall authority of the project is personally supervised by Ltd. Mrs. Tetiana Kazachek who is responsible for supervising of data collection, measurements, calibration, data recording and storage related to this JI Project at “Rivneteploenergo”, Ltd.</p> <p>The responsibilities and authorities are described for each individual in job descriptions as required statutorily.</p>
<b>2. Conformance with monitoring plan</b>		
<b>2.1. Reporting procedures</b>		<p>The monitoring plan is as per the registered PDD. The applauded version 08 of PDD is publicly available at the site <a href="http://ji.unfccc.int/JI_Projects/DeterAndVerif/Verification/PDD/index.html">http://ji.unfccc.int/JI_Projects/DeterAndVerif/Verification/PDD/index.html</a> where it was placed during determination process.</p> <p>The monitoring methodology developed for “District Heating” projects in Ukrainian conditions” was used in monitoring process.</p>



## VERIFICATION REPORT

<b>2.2. Necessary Changes</b>	Full	<p>Implementation of boiler houses rehabilitation and network rehabilitation is realized according to the project plan.</p> <p>Same changes also were made in the monitoring methodology developed for “District Heating” projects in Ukrainian conditions”. Those changes concerned Adjustment factors calculations and allow to calculate GHG emissions reduction more transparent.</p>
<b>3. Application of GHG determination methods</b>		
<b>3.1. Methods used</b>	Full	The reporting procedures reflect the monitoring plan content. The calculation of the emission reduction is correct.
<b>3.2. Information/process flow</b>	Full	<p>The necessary procedures have been defined in internal procedures and additional internal documents relevant for the determination of the various parameters on regular basis.</p> <p>Registration of Natural gas consumption at boiler houses of Measured by “Rivneteploenergo”, Ltd., ME RCC „Teplotransservise” and other enterprises involved in the project is carried out by the following scheme:</p> <ol style="list-style-type: none"> <li>1. All boiler-houses are equipped with gas flow meters.</li> <li>2. Operators of all boiler-houses register the instrument readings in the paper journals “Journal of registration of boiler-house’s operation parameters” every day.</li> <li>3. At the boiler-houses that are not equipped with gas volume correctors , operators register parameters of gas: temperature and pressure in these journals every 2 hours. These parameters are used</li> </ol>



## VERIFICATION REPORT

		to bring gas consumption to normal conditions. 4. Every day operators transfer values of gas consumption to dispatchers of the corresponding enterprises: "Rivneteploenergo", Ltd, ME RCC „Teplotransserve", ME RCC "Komunenergiya", ME "ZdolbunivKomunenergiya"of Zdolbuniv City Council and ME "Teploservis" of Dubrovitsa Regional Council by phone. Monthly they transfer the paper report. Data are storing in the Production-Technical departments (PTD) and used for payments with gas suppliers.
<b>3.3. Data transfer</b>	Full	The complete data is stored electronically and also the part of Management information system which is controlled by accounts
<b>3.4. Data trails</b>	Full	The necessary procedures have been defined in internal procedures and additional internal documents relevant for the determination of the all the parameters listed in the monitoring plan
<b>4. Identification and maintenance of key process parameters</b>		
<b>4.1. Identification of key parameters</b>	Full	The critical parameters for the determination of GHG emissions are the parameters listed in section D of the approved PDD
<b>4.2. Calibration/maintenance</b>	Full	The company maintains the elaborate calibration plan for each of the equipment. The audit team verified the status for all the equipment at the sites sampled for the audit and found them to be complying with the plan.
<b>5. GHG Calculations</b>		



VERIFICATION REPORT

<p><b>5.1. Use of estimates and default data</b></p>	<p>Full</p>	<p>In the monitoring report has been defined a list of fixed default values, measured, and calculated values.</p> <p>There are default values, such as: Number of Customers, Heating area (total), Heating area of buildings (previously existed in the base year) with the renewed (improved) thermal insulation in the reported year, Heating area of newly connected buildings (assumed with the new (improved) thermal insulation) in the reported year, Heat transfer factor of buildings with the new thermal insulation, Standard specific discharge of hot water per personal account, Carbon emission factor, and Recalculating factor for average load during heating period.</p> <p>There are measured values, such as: Fuel consumption at boiler houses, Average annual Heating Value of a fuel calculated by Lower Heating Value, Average outside temperature during the heating season, Average inside temperature during the heating season, Duration of the heating period, Duration of the hot water supply period, Scheduled electric power production by the all new CHP units and electric power generation by the installed new CHP units in reported year, and Electric power consumption by the boiler-houses where energy saving measures are scheduled to be implemented.</p> <p>There are calculated values, such as: Average annual Heating Value of a fuel calculated by Lower Heating Value, Average outside temperature during the heating season, Average inside temperature during the heating season, Average heat transfer factor of heated buildings in the base year, Maximum connected load to the boiler-house, that is required for heating, Connected load to the boiler-house, that is required for hot water supply service, and Scheduled electric power production by the all new CHP units and electric power generation by the installed new CHP units in reported year.</p>
--	-------------	---



## VERIFICATION REPORT

<b>5.2. Guidance on checks and reviews</b>	Full	Internal audits and control measures are performed. Measurement equipment calibration was carried out by Ivano-Frankivsk city JSC "Promprylad", Ltd. "Rivnegaz", Ltd. "Dobrobut" t. Kvasyliv, Derzhstandartmetrologiya of Rivne city, "Grempis" Vinnytsa city, "Apater" Poland.
<b>5.3. Internal validation and verification</b>	Full	Monitoring procedure for JI Project includes the responsibility and frequency for carrying out internal audits. The audit team did verify all the parameters listed in monitoring report
<b>5.4. Data protection measures</b>		The necessary procedures relating to Information technology are in place to provide necessary data security, and also prevent the unauthorized use of the same.
<b>5.5. IT systems</b>	Full	The IT system is server based and located in head quarters in Rivne and has full fledged manpower. The department is also supported by the internal guidelines and procedures to allocate roles and rights for each user. Additionally it clearly defines the responsibility, authority for back up, archiving and protection of data and equipments.

**Periodic Verification Protocol Table 3: GHG calculation procedures and management control testing**

<b>Identification of potential reporting risk</b>	<b>Identification, assessment and testing of management controls</b>	<b>Areas of residual risks</b>
Potential reporting risks based on an assessment of the emission estimation	Regarding the potential reporting risks identified in the left column the following	The issue remaining is the way the data obtained is used to calculate the emission



VERIFICATION REPORT

Identification of potential reporting risk	Identification, assessment and testing of management controls	Areas of residual risks
<p>procedures can be expected in the following fields of action:</p> <ul style="list-style-type: none"> <li>➤ the calculation methods,</li> <li>➤ raw data collection and sources of supporting documentation,</li> <li>➤ reports/databases/information systems from which data is obtained.</li> </ul> <p>Key source data applicable to the project assessed are hereby:</p> <ul style="list-style-type: none"> <li>➤ metering records (gas and power consumption per heat generated),</li> <li>➤ process monitors (heat generation),</li> <li>➤ operational logs (metering records),</li> <li>➤ laboratory/analytical data (for energy content of fuels),</li> <li>➤ accounting records,</li> </ul> <p>Appropriate calibration and maintenance of equipment resulting in high accuracy of data supplied should be in place.</p> <p>It is hereby needed to focus on those risks that impact the accuracy,</p>	<p>mitigation measures have been observed during the document review and the on site mission:</p> <p>Key source data for this parameter are:</p> <ul style="list-style-type: none"> <li>• meter reading.</li> <li>• Invoices and record for Fuels (and coal) for consumption and purchase.</li> </ul> <p>The metering equipments are installed appropriately in the enclosure panels and same are of reputed make.</p> <p>Calculation methods: The reporting procedures reflect the monitoring plan content and the calculation of the emission reduction is correct and also additionally deducting the project emissions caused by fossil fuel.</p>	<p>reduction in a conservative manner according to the approach prescribed in the PDD as well as the way data obtained is used to calculate the emissions reductions/</p>



VERIFICATION REPORT

Identification of potential reporting risk	Identification, assessment and testing of management controls	Areas of residual risks
<p>completeness and consistency of the reported data. Risks are weakness in the GHG calculation systems and may include:</p> <ul style="list-style-type: none"> <li>➤ manual transfer of data/manual calculations,</li> <li>➤ position of the metering equipment,</li> <li>➤ unclear origins of data,</li> <li>➤ accuracy due to technological limitations,</li> <li>➤ lack of appropriate data protection measures (for example, protected calculation cells in spreadsheets and/or password restrictions).</li> </ul>		

**Periodic Verification Protocol Table 4: Detailed audit testing of residual risk areas and random testing**

Areas of residual risks	Additional verification testing performed	Conclusions and Areas Requiring Improvement (including Forward Action Requests)
<p>The issue remaining is the way the data</p>	<p>There has been a complete check of data transferred from daily</p>	<p>Having investigated the residual risks, the audit team comes to the following conclusion:</p>





VERIFICATION REPORT

Areas of residual risks	Additional verification testing performed	Conclusions and Areas Requiring Improvement (including Forward Action Requests)
<p>obtained is used to calculate the emission reduction in a conservative manner according to the approach prescribed in the PDD.</p>	<p>consumption and generation readings to the calculation tool. There was no error in such transfer. The correct installation of the metering equipment can be confirmed.</p>	<p>Immediate action is not needed with respect to the current emission reduction calculation. Those corrections have been considered during the verification process, so no residual risk is open.</p>



## VERIFICATION REPORT

<b>Verification Protocol Table 5: Resolution of Corrective Action and Clarification Requests</b>			
<b>Report clarifications and corrective action requests</b>	<b>Ref. to checklist question in tables 2/3</b>	<b>Summary of project owner response</b>	<b>Verification conclusion</b>
<u>Corrective Action Request 1 (CAR1):</u> There is no evidence of written project approvals by the Parties involved. This CAR will be closed after report finalizing.	2.1	Project is pending approval from the German side	This CAR will be closed after report finalizing.
<u>Clarification Request 1 (CL1)</u> Please, clarify the difference between emission reductions achieved and stated in the MR version 02 and the ones calculated in the PDD.	3.3	GH gas emission reduction, that was planed in PDD for 2004, was not achieved because it became necessary more long debugging of launched turbines. Moreover, there was not completely implemented parts of network that connected boiler-house Knyazya Volodymyra, 71 and to area "Pivnichniy", and used to supply hot water to population of this area.	Issue is closed.



VERIFICATION REPORT

	By monitoring	By PDD	
2004	401		20541
2005	24594		22584
2006	39286		27429
2007	39790		29471
2008	45248		36870

Formulae presented in D.1.4. are used to estimate emission reductions in PDD. These calculations was based on equipment efficiency increasing. In the PDD calculations, by the conservatism principle, the minimal guaranteed effects from all energy saving measures were taken in to account .

Also, emission reductions from implemented measures were calculated only for the next years after energy saving measures implementation. In fact result in the form of emissions reduction is achieved immediately after energy saving measures implementation in the year of reconstruction, especially if it was done at the beginning of the year.

Expressly to calculate all emissions reduction from the project, "SVT e.V." (Germany) and Institute of Engineering Ecology invented monitoring methodology for "District Heating"



VERIFICATION REPORT

		<p>projects in Ukrainian conditions that take into account all measures involved in the project and it's peculiarities This methodology is presented in section D (monitoring plan).</p> <p>It is based on the permanent measuring of the fuel consumption and corrections for possible changes of parameters in reporting year comparing to the baseline. The changeable parameters may be the lower heating value of fuels, quality of heating service (providing of normative temperature value inside apartments), weather features, number of customers, etc. As it was mentioned before, this approach eliminates any possibility of reduction of fuel consumption and correspondingly GHG emission due to incomplete delivery of heat to consumers</p> <p>Calculations of emissions reduction in Monitoring Report for 2004-2007 and Monitoring Report for 2008 were prepared in accordance with this methodology.</p>	
<p><u>Clarification Request 2 (CL2)</u> Please provide information on how the level of uncertainty is taken into</p>	<p>3.5</p>	<p>All equipment used by the project executor for monitoring of the relevant parameters is summarized in Annex 4 of Monitoring Report .The table also provides information on equipment type and calibration.</p>	<p>Issue is closed.</p>



VERIFICATION REPORT

<p>account. And please define if the level of uncertainty is taken into account in the final emission reduction calculations.</p>		<p>According to the Monitoring Plan the volume of consumed natural gas was corrected by measurement error using the principle of conservatism. Natural gas consumption in the reported year that used for Project emissions calculations were increased on the level of accuracy of gas flue meters installed at the every boiler-house. See Annex 2, and Annex 4.</p>	
---	--	--	--



---

## APPENDIX B: VERIFICATION TEAM

The verification team consists of the following personnel:

**Ivan G. Sokolov, Dr.Sci (biology, microbiology)**

Internal Technical Reviewer

Bureau Veritas Ukraine HSE Department manager.

He has over 25 years of experience in Research Institute in the field of biochemistry, biotechnology, and microbiology. He is a Lead auditor of Bureau Veritas Certification for Environment Management System (IRCA registered), Quality Management System (IRCA registered), Occupational Health and Safety Management System, and Food Safety Management System. He performed over 130 audits since 1999. Also he is Lead Tutor of the IRCA registered ISO 14000 EMS Lead Auditor Training Course, and Lead Tutor of the IRCA registered ISO 9000 QMS Lead Auditor Training Course. He has undergone intensive training on Clean Development Mechanism /Joint Implementation and he is involved in the validation of 6 JI projects.

**Nadiia Kaiun M. Sci. (environmental science)**

Team Leader, Climate Change Verifier

Bureau Veritas Ukraine HSE Department project manager.

She has graduated from National University of Kyiv-Mohyla Academy with the Master Degree in Environmental Science. She is a Lead auditor of Bureau Veritas Certification for Environment Management System (IRCA registered). She performed over 15 audits since 2008. She has undergone intensive training on Clean Development Mechanism /Joint Implementation and she is involved in the validation of 6 JI projects.

**Kateryna Zinevych, M. Sci. (environmental science)**

Team member, Climate change Verifier



---

**VERIFICATION REPORT**

---

Bureau Veritas Ukraine HSE Department project manager.

She has graduated from National University of Kyiv-Mohyla Academy with the Master Degree in Environmental Science. She is an auditor of Bureau Veritas Certification for Environment Management System (IRCA registered). She performed 6 audits since March of 2009. She has undergone intensive training on Clean Development Mechanism /Joint Implementation and she is involved in the validation of 3 JI projects.

**Iuliia Gumeniuk, B.Sci. (environmental science)**

Bureau Veritas Ukraine HSE Department Specialist

She has graduated from National University of Kyiv-Mohyla Academy with the Bachelor Degree in Environmental Science. At the moment Iuliia is getting Masters Degree at National University of Kyiv-Mohyla Academy with the Bachelor Degree in Environmental Science.



## APPENDIX C: DOCUMENTS CHECKED DURING VERIFICATION

1. Abbreviate from certificate from 05.04.1988. Chemical analysis.
2. Abbreviate from the attestation protocol #3/215.
3. Abbreviate from the verification protocol G 1600 ЛГ-K-200-1/30-1,6-1Ex. Ser. #3203 from 1996.
4. Abbreviate from the verification protocol G 1600 ЛГ-K-200-1/30-1,6-1Ex. Ser. #3203 from 2006.
5. Abbreviate from the verification protocol G 1600 ЛГ-K-200-1/30-1,6-1Ex. Ser. #5776 from 2006.
6. Accreditation certificate #34/1 of Metrological Service (LLC "Rudmag") dated from 07.03.2006. Valid to 15.06.2009.
7. Accreditation certificate #35 of Metrological Service (LLC "Rudmag") dated from 15.06.2004. Valid to 15.06.2009.
8. Additional working plan of (current) reconstruction of the boiler shops facilities and equipment and CHP (ЦТП) production stations of ME RCC "Teplotransservis" in Rivne 2009.
9. Agenda of reviews of vehicles, machinery, equipments of higher risk to further safe operation term after current operation deadline dated 16.11.2004.
10. Agenda of reviews of vehicles, machinery, equipments of higher risk to further safe operation term after current operation deadline. Approved by Gosnadzorohrantruda of Ukraine #258 dated 16/11/2004.
11. Agreement #374 of electricity usage dated 16/11/2001. Valid to 31/12/2002.
12. Annex to conformity certificate Series ADD #03854.
13. Capital work to repair period 2009-2010 of the ME RCC "Teplotransservis".
14. Certificate #18.
15. Certificate of acceptance of the gas meter G 1600 ЛГ-K-200-1/30-1,6-1Ex. Serial # 5776. Verification date 07/08/2006.
16. Certificate of the acceptance of ЛГ-K-200-1600-16-01-Ex. Serial number 3203. Verification date 22/06/2006.
17. Certificate of the attestation #28 of the Meteorological Service (LLC "Rudmag") dated 15/06/2009, valid to 15/06/2014.
18. Certificate of the attestation #29 of the Meteorological Service (LLC "Rudmag") dated 15/06/2009, valid to 15/06/2014.
19. Certificate of the state meteorological attestation #3/215 dated 12/05/2008.
20. Certification #16
21. Certification of boiler production quality. Boiler serial #1433. Boiler was re-registered 01/02/1999. Steam boiler ДКБП 10/13 oct 3619-76 зав. №1433.
22. Certification of boiler production quality. Boiler serial #1435.
23. Certification of boiler production quality. Production remission #18 dated 19/11/1993.
24. Certification of boiler production quality. Serial #1011 dated September 1965.
25. Certification of boiler production quality. Serial #1101 dated June 1966.
26. Certification of boiler production quality. Serial #1146 dated July 1966.
27. Certification of boiler production quality. Serial #22705. Boiler was re-registered on 21/12/1998.





## VERIFICATION REPORT

28. Certification of boiler production quality. Serial #268, it was produced on December 1965.
29. Certification of the boiler installation quality.
30. Certification of the steam boiler installation quality.
31. Conformity certificate Series AA #05703. Steel heating boiler. Period of validity from 27/04/2007 to 26/04/2009.
32. Contract #2047 on the supply and use of electricity. Valid to 30.04.2004.
33. Contract #2047 on the supply of electricity from 01.07.2005.
34. Contract #374.010 on the supply and use of electricity. Valid to 31.12.2003.
35. Contract #374.010 on the supply of electricity. Valid to 31.12.2007.
36. Contract #521 from 05.07.2004.
37. Data on the duration of the heating period and the average outside air temperature for the calendar years.
38. Data on the duration of the heating period and the average outside air temperature.
39. Decision of the Rivne Regional Council dated 01/08/2006.
40. Decision #381 of the Rivne Regional Council (Fourth convocation) of the reorganization of the separate communal heat power enterprise dated 17/06/2004.
41. Decision #616 of the Rivne Regional Council (Fourth convocation) of communal enterprises "Teplotransservis" of the Rivne Regional Council, "Teplokomunservis" of the Rivne Regional Council dated 09/08/2005.
42. Diagram of the boiler shop technological pipelines with boilers Vitomax 200M24 on the Kyivska 6-A Street.
43. Direction #360 of the head of Regional State Administration of the commission for the complete property complexes transfer of КП "Teplotransservis" of the Rivne Regional Council and КТП "Komunenergia" dated 15/08/2006. Annex to the direction #360 of the head of obldzhradministratsii dated 15/08/2006.
44. Directive on the outcome of the enterprise in the winter 2009-2010 and targets to prepare for heating season 2009-2010 pp.from 30.04.2009 #231.
45. Expert opinion on the results of expert examination #25321716-09-25-0024-07 from 07.08.2007.
46. Gas meter G 1600. ЛГ-К-200-1/30-1,6-1-Ex.
47. Gas meter G 650. ЛГ-К-150-1/30-1,6-1-Ex.
48. Information letter on availability and characteristics of the feeders from 06.06.2001.
49. Information letter on availability of chemical purification and feeders for water heating boiler "Viessmann Vitomax 200 M241".
50. Information letter on the water line project from 06.06.2001.
51. Information on the actual average temperature of external air for the last years in Rivne.
52. Information on the connected loading of hot water supply at the boiler shops on 01.09.2004.
53. Information on the number of consumers (people) who were using hot water supply and standards for gas consumption in the absence of hot water supply during the summer 2002.
54. Information on the number of consumers (people) who were using hot water supply and standards for gas consumption in the absence of hot water supply



## VERIFICATION REPORT

- during the summer 2003.
55. Information on the number of consumers (people) who were using hot water supply during the year 2002.
  56. Information on the number of consumers (people) who were using hot water supply during the year 2003.
  57. Information on the results of the survey. Certified by SOC "Expert Technical Centre in Rivne". Valid to 07.08.2011.
  58. Information on the results of the survey. Certified by the Expert Technical Centre of State Labor Inspection in Rivne.
  59. Instruction on fire safety measures in the buildings of the boiler shop ГРВ #2
  60. KVG-65 #1. P-#389.
  61. KVG-65 #2. P-#390.
  62. KVG-65 #3. P-#550.
  63. Letter #193 to the director E.A. Kezle of the "Viessmann GmbH" company dated 20/04/2003.
  64. Letter #41 to the director E.A. Kezle of OJSC "Viessmann" dated 13/03/2006.
  65. Licence of construction quality dated 11/07/2001.
  66. Licence of construction quality dated 25/10/2007.
  67. Licence Series OB #000572 of State Committee for Nuclear Regulation in Ukraine
  68. Licence Series AB #119652 of Ministry of Construction, Architecture and Housing of Ukraine. Construction activity. Term of validity: from 04.08.2006 to 04.08.2011.
  69. Licence Series AB #147952 on heat energy production at central heating and power plants and at the plants using non-conventional and renewable sources of energy. Term of validity: from 21.09.2006 to 20.09.2009.
  70. Licence Series AB #345053 of Ministry of Housing from 18.06.2007.
  71. Licence Series AB #345069 of Ministry of Housing from 18.06.2007.
  72. Licence Series AB #372622 State Inspector General's Department for Highway Transportation (Golovavtotransinspekciia) from 29.08.2007.
  73. Licence Series АБ #9220972 on the electricity supply according to the uncontrolled rate. Term of validity: from 24.09.2003 to 23.09.2011.
  74. Licence Series ПС #1221 on right to conduct entrepreneurial business of electricity supply according to the uncontrolled rate. Validity period of the licence: from 24.09.2003 to 23.09.2006.
  75. List of general works connected with enterprise preparation to work at the heating season 2009-2010.
  76. List of works proceeding of construction activity to the license AB #119652, issued by the Ministry of Construction, Architecture and Housing and Communal Services of Ukraine dated 04/08/2006. Directive #32-П (invalid without the license).
  77. Logbook for the boiler shop with the boilers of ДКБП type. The boiler #5.
  78. Logbook of boilers operation #7 Б-25-15 from 02.01.2007 to 01.03.2007.
  79. Logbook of boilers operation #7 Б-25-15 from 03.11.2006.
  80. Logbook of boilers operation Б-25-15 from 08.02.2007 to 31.03.2008.
  81. Logbook of changes.
  82. Logbook of gas metering (December-January 2008)
  83. Logbook of gas metering from 01.02.2009.



## VERIFICATION REPORT

84. Logbook of gas metering from 01.11.2002 to 01.02.2003.
85. Logbook of gas metering from 15.10.2007.
86. Logbook of the boiler supervisor.
87. Logbook of work of the boiler shop equipment from July 2004 to November 2004/
88. Logbook. Heating season 2009-2010. КТП PMP "Komunenergiia"
89. Logbook. Repairing period 2009-2010. КТП PMP "Teplotransservis"
90. Logbook. Water heating boiler ПТВМ-30м st.#3. Reg. #R1095
91. Methods of calculating the heat load for heating residential and public buildings.
92. Number of actual electricity consumption by the boiler shops for 2002-2008.
93. Number of persons of each boiler shop who were provided with hot water for 2002-2008.
94. Number of rooms of each boiler shop which were provided with hot water for 2005-2008.
95. OE-VPT-0,68/100. Ser. #27405 dated from 10-2007.
96. Organizational and technical measures which will be implemented in order to save fuel and energy resources at heating objects КП PMP "Teplotransservis" and КТП PMP "Komuneregiiia" in 2009.
97. Parameter chart #3 of the boiler E-2,5-0,9.
98. Parameter chart of the boiler work ДКВР 10/13 #4.
99. Parameter chart of the boiler work ДКВР 10/13 #6.
100. Parameter chart of the test results of the boiler #1 reg.#E-657 dated 05/02/2008.
101. Parameter chart of the test results of the boiler #2 reg.#E-655 dated 05/02/2008.
102. Parameter chart of the test results of the boiler #3 reg.#E-655 dated 05/02/2008.
103. Passport of boiler reg. #P-1850
104. Passport of boiler reg. #P-436
105. Passport of boiler reg. #P-437
106. Passport of boiler reg. #P-439
107. Passport of boiler. Reg. #E-655. Vitomax 200 M 241. Serial #187007094.
108. Passport of boiler. Reg. #E-656. Vitomax 200 M 241. Serial #187007093.
109. Passport of boiler. Reg. #E-657. Vitomax 200 M 241. Serial #187007092.
110. Passport of heated boiler reg. #P-1095 inv. #8690
111. Passport of steam boiler #6. Reg. #1091.
112. Passport of steam boiler #P-1090.
113. Passport of steam boiler E-2,5-0,9ГМ ГОСТ3619-82 reg. #P-1708.
114. Passport of steam boiler. Belgorod boiler plant.
115. Passport of steam boiler. Dorogobuzh boiler plant.
116. Passport of steam boiler. Reg. #7092.
117. Passport. Hot water boiler ТВГМ-30. P-1094.
118. Passport. Hot water boiler. Reg. #P-1094.
119. Passport. Multichannel detector of analog signals MPC-8-30200-IP20, serial #1829. Released date 01.2008.
120. Passport. Multichannel detector of analog signals MPC-8-30200-IP20, serial #1829. Released date 01.2008.



## VERIFICATION REPORT

121. Permission #157 ПП 98 territorial administration of State Labor Inspection in Rivnenska region from 30.12.1998.
122. Permission #560074 for emissions of pollutants in the atmosphere by stationary sources from 13.07.2000.
123. Permission #5610100000-51 for emissions of pollutants in the atmosphere by stationary sources from 01.10.2007.
124. Permission dated from 26.01.2009 for start-up operations. Valid to 04.06.2009.
125. Permission for start-up operations from 30.05.2008.
126. Permission for the commissioning of the boiler from 18.07.1973.
127. Permission for the continuation of high-risk work #283.06.46-45.33.1 with the annex to the permission. Term of validity: from 30.06.2006 to 29.06.2011.
128. Permission for the continuation of high-risk work #2853.05.30-74.30.0 with the annex to the permission. Term of validity: from 24.11.2005 to 24.11.2010.
129. Permission for the continuation of the boiler work from 16.10.1979.
130. Permission to start of facility operation #1924.06.30-28.30.0 with the annex to the permission. Term of validity: from 03.08.2006 to 03.08.2009.
131. Permission to start of facility operation #3389.07.30-28.30.0 with the annex to the permission. Term of validity: from 28.11.2007 to 28.11.2010.
132. Photo - Boiler #1 type ДКБП 10/13 reg. #P-438 inv. №400/705
133. Photo - Boiler #2 type Е-4-14ГМ
134. Photo - Boiler #4 type ДКБП 10/13
135. Photo - Boiler #5 type ДКБП 10/13
136. Photo - Boiler #6 type ДКБП 10/13
137. Photo - Boiler #6. Register #P-1091.
138. Photo - Boiler #7. Register #P-1090.
139. Photo - Boiler #7. Register #P-1092.
140. Photo - Boiler Е-2,5-0,9ГМ
141. Photo - Boiler ИИСТУ-5 #1 inventory #2720
142. Photo - Boiler ИИСТУ-5 #2 inventory #2719
143. Photo - Boiler ИИСТУ-5 #3 inventory #2718
144. Photo - Boiler ИИСТУ-5 #4
145. Photo - Boiler ИИСТУ-5 #6 inventory #1769
146. Photo - Boiler ИИСТУ-5 #7
147. Photo - Boiler ИИСТУ-5 #8 inventory #1768
148. Photo - Boiler ИИСТУ-5 #9
149. Photo - Fueling pump К-20/30 #2
150. Photo - Gas meter G 1600 ЛГ-К-200-1/30-1,6-1-Ex
151. Photo - Gas meter ЛГ-80-180-18-04
152. Photo - Heater of water network ПДС-4-200 №1
153. Photo - Heater of water network ПДС-4-200 №2
154. Photo - Heater of water network ПДС-4-200 №3
155. Photo - Network pump #1 6НД3-60
156. Photo - Network pump #1 К-290/30
157. Photo - Network pump #2 Д 320/70
158. Photo - Network pump #2 К-290/30
159. Photo - Pump of water network #4 GRUNDFOS TP 100-700/2/ Released year 2007.
160. Photo - Regime pump #1 Д 320/70.



## VERIFICATION REPORT

161. Photo - Steam turbine #1. Type P 2,5-15/3 м
162. Photo - Steam turbine #2. Type P 2,5-15/3 м
163. Photo - Transducer of pressure difference Сапфир-22М-ДД Model 2440
164. Photo - Turbogenerator. Type Т-8,5-293. Ser. # 57873.
165. Photo - VLT. HVAC Drive.
166. Photo - Water pump ЦНСГ 38/44
167. Photo - КТП PMP "Komunenergia". Boiler shop.
168. Photo- Differential manometer ДМ-3583М ТУ25-02031698-78
169. Planned substitution of heating networks emergency areas from isolated pipes in the polyurethane wrapper by КП PMP "Teplotransservis" production stations in 2009, Rivne.
170. Planned substitution of heating networks emergency areas from isolated pipes in the polyurethane wrapper by КТП PMP "Komunenergia" production stations in 2009, Rivne.
171. Primary substitution of the heat networks from isolated pipes in the polyurethane wrapper by КП PMP "Teplotransservis" production stations in 2009, Rivne.
172. Primary substitution of the heat networks from isolated pipes in the polyurethane wrapper by КТП PMP "Komunenergia" production stations in 2009, Rivne.
173. Producer warranties. Verification date 28.07.2008.
174. Program of the steam boiler expert examination, type Б25/15 ГМ. Serial #1101; reg. # 3-1091 dated 03/07/2007.
175. Protocol #2 of metering of relative ovality, the control scope in accordance to "Regulation of technical diagnostics of power equipments of Ministry of Industrial Policy of Ukraine enterprises".
176. Protocol #3 of the magnet powder control results. Licence 9309.
177. Protocol #4 of the magnet powder control results. Licence 9309.
178. Protocol #5 of the magnet powder control results. Licence 9309.
179. protocol #8 of wall thickness measuring.
180. Protocol on agreement of agreed price to the scientific and technical products "preparation of output information for the application creation to CO2 emission reduction JI project due to creation of the mini-CHP based on the heating boiler shop" in accordance to the contract #521 dated 05/07/2004.
181. Registration #31 of the boiler dated 28/11/1968.
182. Registration. Boiler register #9226. Boiler re-registration 19/12/2005.
183. Registration. Heating water boiler Vitomax 200 M 241. Serial #187007092. Register #E-657 dated 30/10/2007.
184. Registration. Heating water boiler Vitomax 200 M 241. Serial #187007093. Register #E-656 dated 30/10/2007.
185. Registration. Heating water boiler Vitomax 200 M 241. Serial #187007094. Register #E-655 dated 30/10/2007.
186. Report on the results of the fuel, heat energy and electricity for January-December 2002.
187. Report on the results of the fuel, heat energy and electricity for January-December 2003.
188. Report on the results of the fuel, heat energy and electricity for January-December 2004.



## VERIFICATION REPORT

189. Report on the results of the fuel, heat energy and electricity for January-December 2005.
190. Report on the results of the fuel, heat energy and electricity for January-December 2006.
191. Report on the results of the fuel, heat energy and electricity for January-December 2007.
192. Report on the results of the fuel, heat energy and electricity for January-December 2008.
193. Report on the start-up test of three water heating boilers Vitomax 200 M241 of the company Viessmann with power of 9,3 MW installed at the boiler shop at 6a Kyivska street in Rivne from 05.02.2008.
194. Resolution #630 on approval of rules of providing central heating services, hot and cold water supply and drainage system, and model contract of providing central heating services, hot and cold water supply and drainage system dated 21/07/2005.
195. Schedule of certification of buildings, structures (chimneys) 2009.
196. Schedule of hot water supply by the boiler shops for 2002-2008.
197. Schedule of hydraulic tests of heating networks КП PMP "Komunenergia" during repairing period 2009-2010.
198. Schedule of hydraulic tests of heating networks КП PMP "Transservis" during repairing period 2009-2010.
199. Schedule of repairing roofs of boiler rooms.
200. Scheme of boiler heating networks on Soborna Street 225-K.
201. Scheme of gas equipment к/a Vitomax 200 M 241 #2 boiler on Kyivska Street 6-A.
202. Scheme of the boilers expert examination (technical diagnostics), pipelines that installed at the boiler shops of КП "Teplotransservia" and КТП "Komunenergia" and technical certifying by experts in 2009.
203. Scheme of the staff evacuation from the first floor of the boiler shop in case of the fire dated 02/04/2004.
204. Scheme of gas bleeding ГРП #1 boiler on Kuivska Street 6-A.
205. Specification dated 03/02/2003.
206. Specification dated 26/02/2003.
207. Standards and guidelines for regulation of fuel and heat energy consumption by heating residential and public buildings, and for dwelling-living needs in Ukraine. 1995.
208. State statistical observation. Report on the heat energy supply for the year 2003 from 12.01.2005.
209. State statistical observation. Report on the heat energy supply for the year 2004 from 17.01.2005.
210. State statistical observation. Report on the heat energy supply for the year 2004 from 20.01.2005.
211. State statistical observation. Report on the heat energy supply for the year 2005 from 10.01.2009.
212. State statistical observation. Report on the heat energy supply for the year 2006 from 15.01.2007.
213. State statistical observation. Report on the heat energy supply for the year 2007 from January 2007.



## VERIFICATION REPORT

214. State statistical observation. Report on the heat energy supply for the year 2008 from January 2009.
215. State statistical observation. Report on the results of the use of fuel, heat and electricity for January-December 2002 from 10.01.2003.
216. State statistical reporting. Report on the heat energy supply for the year 2002 from January 2004.
217. Statement #1 of visual inspection and geometric measurements of collector elements, water circulators, pipes of heating surfaces. Certificate #8131/
218. Statement dated from 01.03.2003. SOC "Dubrovytsiakomunenergiia"
219. Statement of analysis of operation, design and repair documentation and expert examination of metal steam boiler metal ser. #1101, reg. #1091, st. #6 installed at the boiler shop on Pr. Volodymyr street in Rivne dated from 06.08.2007.
220. Statement of boiler testing on steam density and adjustment of relief valves dated from 03.11.1993.
221. Statement of fettling of automatics of boiler safety and signalling at the boiler shop on 6A Kyivska street dated from 26.10.2008.
222. Statement of fettling of automatics of steam boiler safety 525/15 ГМ #7 at the boiler shop on 75 Pr. Volodymyr street dated from 03.01.2008.
223. Statement of fettling of automatics of water heating boiler safety ТБГМ-30 #1 at the boiler shop on 75 Pr. Volodymyr street dated from 15.10.2007.
224. Statement of hydraulic testing of the boiler dated from 06.08.2007.
225. Statement of repairment and fettling of automatics of boiler safety and signalling at the boiler КТП PMP "Komunenergiia" dated from 02.09.2008.
226. Statement of SOC "Dubrovytsiakomunenergiia" dated from 01.03.2002
227. Statement of working order of the boiler dated from 06.06.2001.
228. Statement of working order of the boiler dated from 25.10.2007.
229. Statute #38/01 of utility enterprise "Teplotransservis" of Rivne city council dated 26/01/2007.
230. Steam boiler ДКБП 10/13 oct. 3619-76 зав. №1135.
231. Table. Amount of actual electricity and heat energy production in 2002-2008 and actual gas spending in 2008 on boiler shops.
232. Table. Amount of actual electricity consumption on boiler shops in 2002-2008.
233. Table. Heating areas in 2002-2008.
234. Table. Indicators of energy consumption of КТП PMP "Teplotransservis".
235. Table. Indicators of energy consumption of КТП PMP "Komunenergiia".
236. Technical passport of the gas-fired burner. AB #200726907.
237. Technical passport P-436
238. Technical passport P-437. Steam boiler F-10-14 (ДКБП 10/13) serial #22705.
239. Technical passport P-439
240. Technical report #25321716-09-25-0024-07 of the expert examination (technical diagnostics).
241. The amendment to the statute of the public enterprises "Teplotransservis" of the administrative board of Rivne #614/01 from 27.11.2008.
242. Thermaks. Type PTA-42, ser. #12. Production year 2008.
243. Turbine gas meter. ЛГ-К-Ex G 1600 ЛГ-К-200-1/30-1,6-1. Passport Ф62. 784. 008 ПС
244. Verification data. Verification date 24.07.08. Quality service.



## VERIFICATION REPORT

245. VITOMAX 200. Low pressure hot water boiler. Type M241 008. Production number 187007092.
246. VITOMAX 200. Low pressure hot water boiler. Type M241 008. Production number 187007093.
247. VITOMAX 200. Low pressure hot water boiler. Type M241 008. Production number 187007094.
248. Waybill #15 from 31.05.2002. TC "Komunenergija"
249. Waybill #18 from 20.02.2002. SOC "Dubrovyciiakomunenergija"
250. Waybill #35328268 from 04.02.2005. TC "Komunenergija"
251. Waybill #35328268 from 04.02.2005. TC "Komunenergija"
252. Waybill #35637614. TC "Komunenergija"
253. Waybill #67 from 31.05.2002. SOC "Dubrovyciiakomunenergija"
254. Waybill for shipment #189 from 20.02.2003. TC "Komunenergija"
255. Work plan of the capital (current) repair of premises and boiler shpo equipments, and ЦТП production stations of КП PMP "Теплотрассервис" in 2009, Rivne.
256. Work plan of the capital (current) repair of premises and boiler shpo equipments, and ЦТП production stations of КП PMP "Komunenergija" in 2009, Rivne.
257. Work scheme of the preparation of heating facilities by КП PMP "Komunenergija" production stations to work in autumn-winter 2009-2010, Rivne.
258. Work scheme of the preparation of КП PMP "Теплотрассервис" heating facilities to work in autumn-winter 2009-2010.
259. MPC-8 Multichannel analog signals recorder. Technical description and operating manual. Passport. 2006.