



VERIFICATION REPORT

VEMA S.A.

VERIFICATION OF THE
REDUCTION OF METHANE EMISSIONS AT
FLANGED, THREADED JOINTS AND SHUT-DOWN
DEVICES OF OJSC “KYIVGAS” EQUIPMENT

7th PERIODIC
FOR THE PERIOD OF 01/03/2012 – 31/08/2012

REPORT № UKRAINE- VER/0680/2012

REVISION № 02

BUREAU VERITAS CERTIFICATION



VERIFICATION REPORT

Date of first issue: 06/09/2012	Organizational unit: Bureau Veritas Certification Holding SAS
Client: VEMA S.A.	Client ref.: Fabian Knodel

Summary:

Bureau Veritas Certification has made the 7th periodic verification of VEMA S.A. project "Reduction of methane emissions at flanged, threaded Joints and shut-down devices of OJSC "Kyivgas" equipment", located in Kyiv, Ukraine, and applying JI-specific approach on the basis of UNFCCC criteria for the JI, as well as criteria given to provide for consistent project operations, monitoring and reporting. UNFCCC criteria refer to Article 6 of the Kyoto Protocol, the JI rules and modalities and the subsequent decisions by the JI Supervisory Committee, as well as the host country criteria.

The verification scope is defined as a periodic independent review and ex post determination by the Accredited Entity of the monitored reductions in GHG emissions during defined verification period, and consisted of the following three phases: i) desk review of the monitoring report against project design and the baseline and monitoring plan; ii) follow-up interviews with project stakeholders; iii) resolution of outstanding issues and the issuance of the final verification report and opinion. The overall verification, from Contract Review to Verification Report & Opinion, was conducted using Bureau Veritas Certification internal procedures.

The first output of the verification process is a list of Clarification, Corrective Actions Requests and Forward Actions Requests (CR, CAR and FAR), presented in Appendix A.

In summary, Bureau Veritas Certification confirms that the project is implemented as per determined changes. Installed equipment being essential for generating emission reduction runs reliably and is calibrated appropriately. The monitoring system is in place and the project is generating GHG emission reductions. The GHG emission reduction is calculated accurately and without material errors, omissions, or misstatements, and the ERUs issued totalize 566 333 tonnes of CO₂ equivalent for the monitoring period period from 01/03/2012 to 31/08/2012.

Our opinion relates to the project's GHG emissions and resulting GHG emission reductions reported and related to the approved project baseline and monitoring, and its associated documents.

Report No.: UKRAINE-ver/0680/2012	Subject Group: JI
Project title: "Reduction of methane emissions at flanged, threaded joints and shut-down devices of OJSC "Kyivgas" equipment"	
Work carried out by: K. Zinevych – Team Leader, Climate Change Verifier O. Kuzmenko - Team member, Technical Specialist	
Work reviewed by: I.Sokolov – Internal technical reviewer V.Kobzar - Technical specialist	
Work approved by: I.Sokolov – Operational Manager	
Date of this revision: 13/09/2012	Rev. No.: 02
Number of pages: 29	

- No distribution without permission from the Client or responsible organizational unit
- Limited distribution
- Unrestricted distribution



Table of Contents		Page
1	INTRODUCTION	4
1.1	Objective	4
1.2	Scope	4
1.3	Verification Team	5
2	METHODOLOGY	5
2.1	Review of Documents	5
2.2	Follow-up Interviews	6
2.3	Resolution of Clarification, Corrective and Forward Action Requests	6
3	VERIFICATION CONCLUSIONS	7
3.1	Remaining issues and FARs from previous verifications	7
3.2	Project approval by Parties involved (90-91)	8
3.3	Project implementation (92-93)	8
3.4	Compliance of the monitoring plan with the monitoring methodology (94-98)	10
3.5	Revision of monitoring plan (99-100)	11
3.6	Data management (101)	11
3.7	Verification regarding programmes of activities (102-110)	14
4	VERIFICATION OPINION	14
5	REFERENCES	16
APPENDIX A: COMPANY PROJECT VERIFICATION PROTOCOL		19



1 INTRODUCTION

VEMA S.A. has commissioned Bureau Veritas Certification to verify the emissions reductions of its JI project “Reduction of methane emissions at flanged, threaded joints and shut-down devices of OJSC “Kyivgas” equipment”, (hereafter called “the project”) in Kyiv city, Ukraine.

This report summarizes the findings of the verification of the project, performed on the basis of UNFCCC criteria, as well as criteria given to provide for consistent project operations, monitoring and reporting.

The verification covers the period from March 1, 2012 to August 31, 2012.

1.1 Objective

Verification is the periodic independent review and ex post determination by the Accredited Independent Entity (AIE) of the monitored reductions in GHG emissions during defined verification period.

The objective of verification can be divided in Initial Verification and Periodic Verification.

UNFCCC criteria refer to Article 6 of the Kyoto Protocol, the JI rules and modalities and the subsequent decisions by the JI Supervisory Committee, as well as the host country criteria.

1.2 Scope

The verification scope is defined as an independent and objective review of the project design document, the project’s baseline study, monitoring plan and monitoring report and other relevant documents. The information in these documents is reviewed against Kyoto Protocol requirements, UNFCCC rules and associated interpretations.

The verification is not meant to provide any consulting towards the Client. However, stated requests for clarifications, corrective and/or forward actions may provide input for improvement of the project monitoring towards reductions in the GHG emissions.



1.3 Verification Team

The verification team consists of the following personnel:

K. Zinevych

Bureau Veritas Certification, Team Leader, Climate Change Verifier

O. Kuzmenko

Bureau Veritas Certification, Team member, Technical Specialist

This verification report was reviewed by:

I. Sokolov

Bureau Veritas Certification, Internal Technical Reviewer

V. Kobzar

Bureau Veritas Certification, Technical Specialist

2 METHODOLOGY

The overall verification, from Contract Review to Verification Report & Opinion, was conducted using Bureau Veritas Certification internal procedures.

In order to ensure transparency, a verification protocol was customized for the project, according to the version 01 of the Joint Implementation Determination and Verification Manual, issued by the Joint Implementation Supervisory Committee at its 19th meeting on 04/12/2009. The protocol shows, in a transparent manner, criteria (requirements), means of verification and the results from verifying the identified criteria. The verification protocol serves the following purposes:

- It organizes, details and clarifies the requirements a JI project is expected to meet;
- It ensures a transparent verification process where the verifier will document how a particular requirement has been verified and the result of the verification.

The completed verification protocol is enclosed in Appendix A to this report.

2.1 Review of Documents

The Monitoring Report (MR) submitted by VEMA S.A. and additional background documents related to the project design and baseline, i.e. country Law, Project Design Document (PDD), Approved CDM methodology, Determination Report of the project issued by Bureau



Veritas Certification Holding SAS No. UKRAINE/0125/2010 as of 08/07/2010, Guidance on criteria for baseline setting and monitoring, Host party criteria, the Kyoto Protocol, Clarifications on Verification Requirements to be Checked by an Accredited Independent Entity were reviewed.

The verification findings presented in this report relate to the Monitoring Report for the period from 01/03/2012 to 31/08/2012, version 01 as of September 03, 2012, and version 02 as of September 10, 2012, and the project as described in the determined PDD.

2.2 Follow-up Interviews

On 04/09/2012 Bureau Veritas Certification verification team performed on-site interviews with project stakeholders to confirm selected information and to resolve issues identified in the document review. Representatives of PJSC “Kyivgas” and VEMA S.A. were interviewed (see References). The main topics of the interviews are summarized in Table 1.

Table 1 Interview topics

Interviewed organization	Interview topics
PJSC “Kyivgas”	<ul style="list-style-type: none"> ➤ Organizational structure ➤ Responsibilities and authorities ➤ Personnel training ➤ Quality control procedures and technology ➤ Equipment use (records) ➤ Metering equipment control ➤ Metering record keeping system, database
Consultant: VEMA S.A.	<ul style="list-style-type: none"> ➤ Baseline methodology ➤ Monitoring plan ➤ Monitoring report ➤ Deviations from the PDD

2.3 Resolution of Clarification, Corrective and Forward Action Requests

The objective of this phase of the verification is to raise the requests for corrective actions and clarification, and any other outstanding issues that needed to be clarified for Bureau Veritas Certification positive conclusion on the GHG emission reduction calculation.

If the Verification Team, in assessing the monitoring report and supporting documents, identifies issues that need to be corrected,

VERIFICATION REPORT

clarified or improved with regard to the monitoring requirements, it should raise these issues and inform the project participants of these issues in the form of:

- (a) Corrective action request (CAR), requesting the project participants to correct a mistake that is not in accordance with the monitoring plan;
- (b) Clarification request (CL), requesting the project participants to provide additional information for the Verification Team to assess compliance with the monitoring plan;
- (c) Forward action request (FAR), informing the project participants of an issue, relating to the monitoring that needs to be reviewed during the next verification period.

The Verification Team will make an objective assessment as to whether the actions taken by the project participants, if any, satisfactorily resolve the issues raised, if any, and should conclude its findings of the verification.

To guarantee the transparency of the verification process, the concerns raised are documented in more detail in the verification protocol in Appendix A.

3 VERIFICATION CONCLUSIONS

In the following sections, the conclusions of the verification are stated.

The findings from the desk review of the original monitoring documents and the findings from interviews during the follow up visit are described in the Verification Protocol in Appendix A.

The Clarification, Corrective and Forward Action Requests are stated, where applicable, in the following sections and are further documented in the Verification Protocol in Appendix A. The verification of the Project resulted in 7 Corrective Action Requests, and 1 Clarification Request.

The number between brackets at the end of each section corresponds to the DVM paragraph.

3.1 Remaining issues and FARs from previous verifications

There are no CLs or FARs remaining from previous verifications.



3.2 Project approval by Parties involved (90-91)

The project obtained approval by the Host party (Ukraine) on 28/07/2010 (Letter of Approval #1121/23/7 issued by the National Environmental Investment Agency of Ukraine as of 28/07/2010) and written project approval by the party – buyer of emission reductions units (Switzerland) (Letter of Approval # J294-0463 issued by the Federal Office for the Environment (FOEN) of Switzerland dated 23/07/2010).

The abovementioned written approvals are unconditional.

The identified areas of concern as to the project implementation, project participants responses and Bureau Veritas Certification's conclusions are provided in Appendix A to this report (refer to CAR 01).

3.3 Project implementation (92-93)

PJSC “Kyivgas” is the company providing natural gas transportation and supply to industrial and domestic consumers as well as to population in the city of Kyiv.

The structure of current gas transport rates regulated by the government does not consider depreciation and investment needs of gas distribution enterprises, which does not ensure receipt of funds for performance of necessary repairs and modernization of gas networks, purchase of appropriate engineering equipment and components, and also results in an increase of natural gas leakage at PJSC “Kyivgas” facilities.

Application of JI project mechanisms provided by the Kyoto Protocol was planned before the beginning of implementation of this project.

Project activities include reduction of methane leakage which is the result of faulty sealing of ground and underground fittings implemented at switch mechanisms (bolts, cocks, valves), flange and threaded joints of PJSC “Kyivgas” gas pipelines in a quantity of 60 613 pieces. Types and quantity of fittings are given in PDD version 03 and Table 2 of this report:

Table 2 Number of pieces of fittings involved in the Project by types

No.	Type of device (type of joint)	Quantity of devices, pcs.
1	Shut-down devices in gas wells– block valves (flanged joint)	6 447
2	Ground shut-down devices – block valves (flanged joint)	10 451
3	Electrical insulating flanges (flanged joint)	22 120



VERIFICATION REPORT

4	Underground shut-down devices of well-less plant - block valves (flanged joint)	3 739
5	Ground shut-down devices - cocks (threaded joint)	17 856
Total		60 613

Within the scope of the project modern compacting materials are used for repair of equipment, for the purpose of methane leaks elimination, replacing service and repair practice based on rubberized asbestos fabric and rubber gaskets, and compacting padding made of cotton fibre with fat soakage and asbestos graphite filler. This practice does not provide a long-term effect, which leads to additional methane leaks. In addition to reduction of methane leaks, the project activity will lead to a reduction of technical leaks of natural gas (and thus, to a decrease of financial costs), and will contribute to an improvement of environmental situation, to reduction of the risk of accidents, especially for in-house gas pressure regulators and overground gas pipelines.

The project activity includes:

- Implementation of purposeful examination and technical maintenance (PETM) of all switch mechanisms (bolts, cocks, valves), flange and threaded joints – a modern and most economically effective practice, which enables not only to detect leaking areas, but also to determine leakage volumes (i.e., potential volume of gas leakage reduction). This key information is required for substantiation of efficiency of repair works and priority choice of its objects, which is important under short financing for elimination of all leakage. This activity will include purchase and calibration of modern measuring equipment, appropriate training of employees, development of a monitoring map for each switch mechanism, flange and threaded joint of gas distribution network, with the list of all equipment components to be regularly examined, creation of a leakage data collection and storage system, and implementation of an internal audit and quality system for elimination and accounting of methane leaks.
- Detection and measurement of leakage: a leakage monitoring system at all switch mechanisms (bolts, cocks, valves), flange and threaded joints, including eliminated leakage (repaired components of equipment). Monitoring will be done on a regular basis (once per four days or once per week – depending on the type of equipment) by specially trained staff. Each component will be checked according to the monitoring map, and leakage detected will be duly marked with individual numbers; gas leakage volumes will be measured and registered in the database.
- Elimination of all leakage detected: repairs of leaking equipment under this project will vary from replacement of gaskets and wedge valves, use of new compactors or sealing materials, to capital



repairs and replacement of the equipment. Repaired equipment components will be regularly checked as part of a standard monitoring program (see above) to make sure they have not become the source of leakage again.

During 2005 – 2009 each of 60 613 switch mechanisms (bolts, cocks, valves), flange and threaded joints of gas pipelines of PJSC “Kyivgas” were modernized or repaired.

The task of the current monitoring period (March 1, 2012 – August 31, 2012) is further accomplishment of purposeful examination and technical maintenance (PETM) of all switch mechanisms (bolts, cocks, valves), flange and threaded joints. Equipment components repaired in 2005-2009 are regularly checked during the current monitoring period as part of the standard monitoring program to make sure they have not become the source of leakage again.

Regular maintenance of equipment components according to the Monitoring Plan, provided in PDD version 03, is conducted once a year, technical maintenance - once per six months.

The measured volumes of methane leakage from repaired PJSC "Kiyivgas" pipelines equipment do not exceed the volumes of leakage, which were measured after the first repair of the equipment.

The project was in operation throughout the monitoring period - from 01/03/2012 to 31/08/2012.

3.4 Compliance of the monitoring plan with the monitoring methodology (94-98)

The monitoring occurred in accordance with the monitoring plan included in the PDD regarding which the determination has been deemed final and is so listed on the UNFCCC JI website.

To calculate the emission reductions such key factors as speed of leakage for each leakage found, gas temperature and pressure, volume of a container, concentration of methane in a sample, time in which the methane concentration of in the container reaches a certain level, experience in implementing measures envisaged by the project, the current practice that exists in Ukraine in this area, financial costs and the availability of expertise, legislation affecting the baseline emissions and the activity level of the project and the emissions as well as risks associated with the project were taken into account, as appropriate.

Data sources used for calculating emission reductions, such as calibrated measuring equipment – EX-TEC® SR5 gas analyzer, SOS pr-2b-2 stopwatch, mercury-in-glass thermometer of TL-4 type, D-59N-100-1/0 6



kPa pressure gauge, information from equipment manufacturers and IPCC are clearly identified, reliable and transparent.

Emission factors, including default emission factors, are selected by carefully balancing accuracy and reasonableness, and appropriately justified of the choice.

The calculation of emission reductions is based on conservative assumptions and the most plausible scenarios in a transparent manner. Monitoring periods per component of the project are clearly specified in the monitoring report and do not overlap with those for which verifications were already deemed final in the past.

Identified problem areas as to the compliance of monitoring plan with monitoring methodology, project participants responses and Bureau Veritas Certification's conclusions are provided in Appendix A to this report (see CAR 02, CAR 03, CAR 04, CAR 05).

3.5 Revision of monitoring plan (99-100)

Not applicable.

3.6 Data management (101)

The data and their sources, provided in the monitoring report, are clearly identified, reliable and transparent.

The implementation of data collection procedures is in accordance with the PDD monitoring plan, including the quality control and quality assurance procedures.

The function of the monitoring equipment, including its calibration status, is in order.

According to current legislation "On metrology and metrological activity", all measuring equipment in Ukraine must meet the specified requirements of relevant standards and is subject to a periodic verification. Calibration of measuring devices is conducted in accordance with national standards.

The evidence and records used for the monitoring are maintained in a traceable manner.

The data collection and management system for the project is in accordance with the PDD and the monitoring plan and consists of three parts:

- 1) Measurements of methane leakage value before the rehabilitation (pressurization) of the facility;
- 2) Measurements of methane leakage value after the rehabilitation (pressurization) of the facility;
- 3) Archiving and processing of obtained results.



To measure leakage volume of natural gas it was decided to use the method based on the Calibrated Bag Technology described in the approved baseline methodology AM0023 "Leak reduction from natural gas pipeline compressor or gate stations". One of the problems incurred by using this method is complicated accounting of the volume of the fittings where measurements are done, and the initial air volume when determining the volume of gas coming in the bag.

To solve these problems a special installation was made on the basis of plastic container of known volume (0.87 m³), package, plastic hose and pressure gauge.

In order to ensure successful implementation of the project and the credibility and verifiability of the emission reductions achieved, the project must have a well-organized management system.

According to distribution of duties between the project parties the organization of monitoring measurements of methane leaks in flanged, threaded joints and shut-down devices of the PJSC "Kyivgas" equipment is undertaken by VEMA S.A. For this purpose VEMA S.A. concludes corresponding contracts with other companies on carrying out such monitoring measurements. Thus, direct monitoring measurements are made by the personnel of these companies, but at presence and under control of PJSC "Kyivgas" and VEMA S.A. representatives. When carrying out monitoring measurements the parties of the project co-ordinate the activity through a working team specially created at PJSC "Kyivgas". Data of monitoring measurements of leakage are fixed and transferred to participants of the project in the electronic form for further processing, calculations and storage.

Coordination of work of all departments and services of PJSC "Kyivgas" concerning project implementation is done by specially created Working team. Renewed structure of Working team is approved by the order № 394 from 14/08/2012 of the Executive Chairman of the Board of PJSC "Kyivgas" Ovcharuk S.S. The structure of Working team is shown on the Picture 1.

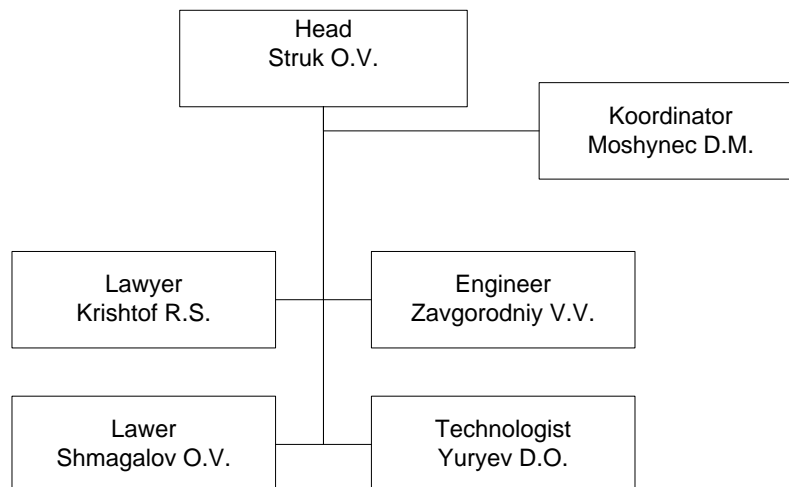

Figure 1 Structure of the Working Team

Head of working team Struk O.V. is responsible for general management of the project and coordination of all actions of the parties, determines plan of measures under the Project and scope of resources required. Yuryev D.O. coordinates collection of all information provided for by monitoring plan, and makes all necessary calculations. Archiving of all received information in the result of measurements and settlements is done under guidance of Moshynec D.M. Technical maintenance of the Project is carried out by Zavgorodniy V.V. Legal support of the Project is carried out by Krishtof P.S. and Shmagalov O.V.

Regular maintenance (once a year) and technical maintenance (once a half year) of flanged, threaded joints and shut-down devices, according to the distribution of duties between the project parties, are carried out by PJSC "Kyivgas".

All the necessary information on monitoring of GHG emissions is stored in paper and/or electronic form until the end of the crediting period and for two years after the last transaction on emission reduction units.

The Monitoring Report version 02 provides sufficient information about the intended role, responsibilities and authorities for implementing and maintaining monitoring procedures, including data management. Verification Team confirms the effectiveness of existing management system and operating system and considers them suitable for reliable monitoring of the project.

Identified problem areas as to the data management, project participants responses and Bureau Veritas Certification's conclusions are provided in Appendix A to this report (see CAR 06, CAR 07, CL 01).



3.7 Verification regarding programmes of activities (102-110)

Not applicable.

4 VERIFICATION OPINION

Bureau Veritas Certification has performed the 7th periodic verification of the project "Reduction of Methane Emissions at Flanged, Threaded Joints and Shut-down Devices of OJSC "Kyivgas" Equipment" for the period of March 1, 2012 – August 31, 2012, which applies JI specific approach. The verification was performed on the basis of UNFCCC criteria and host country criteria and also on the criteria given to provide for consistent project operations, monitoring and reporting.

The verification consisted of the following three phases: i) desk review of the monitoring report against the project design and the baseline and monitoring plan; ii) follow-up interviews with project stakeholders; iii) resolution of outstanding issues and the issuance of the final verification report and opinion.

The management of Vema S.A. is responsible for the preparation of the GHG emissions data and the reported GHG emissions reductions of the project on the basis set out within the project Monitoring Plan indicated in the final PDD version 03. The development and maintenance of records and reporting procedures in accordance with that plan, including the calculation and determination of GHG emission reductions from the project, is the responsibility of the management of the project.

Bureau Veritas Certification verified the Project Monitoring Report version 02 for the reporting period 01/03/2012 – 31/08/2012 as indicated below. Bureau Veritas Certification confirms that the project is implemented as per determined changes. Installed equipment being essential for generating emission reduction runs reliably and is calibrated appropriately. The monitoring system is in place and the project is generating GHG emission reductions.

Emission reductions achieved by the project for the period from 01/03/2012 to 31/08/2012 do not differ significantly from the amount predicted for the same period in the determined PDD. Emission reductions predicted in the determined PDD version 03 and actual emission reductions stated in the MR version 02 are provided in Table 3 of this report.



Table 3 Emission reductions predicted in the determined PDD version 03 and actual emission reductions stated in the MR version 02

Period	Estimated GHG emission reductions stated in the determined PDD in tonnes of CO ₂ eq	Ex-post GHG emission reductions stated in the Monitoring report in tonnes of CO ₂ eq
01/03/2012 - 31/08/2012	563 494	566 333

This difference in the emission reductions under the project "Reduction of Methane Emissions at Flanged, Threaded Joints and Shut-down Devices of OJSC "Kyivgas" Equipment" in 01/03/2012 – 31/08/2012 in the determined PDD and the MR is explained by the fact that accurate conservative values were available during MR development but at the PDD development stage assumptions were made in relation to monitoring period. The quantity of emission reductions for the period from 01/03/2012 to 31/08/2012 that was provided in the determined PDD was identified by dividing the total annual amount of emission reductions by 12 (12 months) and multiplying by 8 (8 months).

Bureau Veritas Certification can confirm that the GHG emission reduction is accurately calculated without material errors, omissions, or misstatements. Our opinion relates to the project's GHG emissions and resulting GHG emissions reductions reported and related to the approved project baseline and monitoring, and its associated documents. Based on the information we have seen and evaluated, we confirm, with a reasonable level of assurance, the following statement:

Reporting period: from 01/03/2012 to 31/08/2012

Baseline emissions : 601 966 tonnes of CO₂ equivalent.
 Project emissions : 35 633 tonnes of CO₂ equivalent.
 Emission Reductions: : 566 333 tonnes of CO₂ equivalent.



5 REFERENCES

Category 1 Documents:

Documents provided by the project participants that relate directly to the GHG components of the project.

/1/	PDD of the JI project "Reduction of methane emissions at flanged, threaded joints and shut-down devices of OJSC "Kyivgas" equipment", version 03, as of July 7, 2010
/2/	Monitoring Report of the JI project "Reduction of methane emissions at flanged, threaded joints and shut-down devices of OJSC "Kyivgas" equipment", dated 01/03/2012 – 31/08/2012, version 01, as of September 03, 2012
/3/	Monitoring Report of the JI project "Reduction of methane emissions at flanged, threaded joints and shut-down devices of OJSC "Kyivgas" equipment", dated 01/03/2012 – 31/08/2012, version 02, as of September 10, 2012
/4/	Appendix A. Summary calculation of GHG emission reductions at flanged, threaded joints and shut-down devices of OJSC "Kyivgas" equipment" for 6 months (from March 1 to August 31, 2012).
/5/	Determination Report of the JI project "Reduction of methane emissions at flanged, threaded joints and shut-down devices of OJSC "Kyivgas" equipment" of Bureau Veritas Certification Holding SAS No. UKRAINE/0125/2010, dated July 8, 2010
/6/	Verification Report of the JI project "Reduction of methane emissions at flanged, threaded joints and shut-down devices of OJSC "Kyivgas" equipment" on early credits of Bureau Veritas Certification Holding SAS as of August 03, 2010
/7/	Verification Report of the JI project "Reduction of methane emissions at flanged, threaded joints and shut-down devices of OJSC "Kyivgas" equipment" for 2008 of Bureau Veritas Certification Holding SAS, No. UKRAINE-ver/0127/2010 as of August 03, 2010
/8/	Verification Report of the JI project "Reduction of methane emissions at flanged, threaded joints and shut-down devices of OJSC "Kyivgas" equipment", for 2009 of Bureau Veritas Certification Holding SAS, No. UKRAINE-ver/0128/2010, as of August 03, 2010
/9/	Verification Report of the JI project "Reduction of methane emissions at flanged, threaded joints and shut-down devices of OJSC "Kyivgas" equipment" for the period of 01/01/2010-30/09/2010 of Bureau Veritas Certification Holding SAS, No. UKRAINE-ver/0171/2010 as of October



VERIFICATION REPORT

	13, 2010
/10/	Verification Report of the JI project "Reduction of methane emissions at flanged, threaded joints and shut-down devices of OJSC "Kyivgas" equipment" for the period of 01/10/2010-30/04/2011 Bureau Veritas Certification Holding SAS, No. UKRAINE-ver/0277/2011, as of May 10, 2011
/11/	Verification Report of the JI project "Reduction of methane emissions at flanged, threaded joints and shut-down devices of OJSC "Kyivgas" equipment" for the period of 01/05/2011-31/07/2011 Bureau Veritas Certification Holding SAS, No. UKRAINE-ver/0336/2011, as of August 05, 2011
/12/	Verification Report of the JI project "Reduction of methane emissions at flanged, threaded joints and shut-down devices of OJSC "Kyivgas" equipment" for the period of 01/05/2011-31/07/2011 Bureau Veritas Certification Holding SAS, No. UKRAINE-ver/0447/2012, as of March 06, 2012
/13/	Letter of Approval issued by the National Environmental Investment Agency of Ukraine № 1121/23/7 dated 28/07/2010
/14/	Letter of Approval issued by the Swiss Federal Office for the Environment (FOEN) J294-0463 as of July, 23 2010

Category 2 Documents:

Background documents related to the design and/or methodologies employed in the design or other reference documents.

/1/	Preliminary investment agreement relating to the JI project
/2/	Register of shut-down devices, flanged and threaded joints, where the measurements of emissions were conducted
/3/	Program of baseline study of flanged, threaded joints and shut-down devices of PJSC "Kyivgas" equipment, elaborated by VEMA S.A.
/4/	State Metrological Certificate No. 08/0301 dated 01/07.2011 (EX-TEX® SR5 gas analyzer, No. 041111002306,27/05/2009)
/5/	Photos of methane leaks measurements taken with the help of EX-TEX® SR5 gas analyzer for the period of 01/03/2012 – 31/08/2012
/6/	Photos of equipment installed under the project
/7/	Passport of EX-TEX® SR5 portable gas analyzer
/8/	User manual 9P2.832.012 RE (barometers and domestic barometers)
/9/	Passport of D-59N-100-1.0 6 kPa manometer
/10/	Passport of SOS pr-2b-2 stopwatch
/11/	Calibration certificate of the working measuring instrument No. 81127/10 (EX-



VERIFICATION REPORT

	TEC [®] SR5) dated 12/07/2012
/12/	Calibration certificate of the working measuring instrument No. 81127/8 (EX-TEC [®] SR5) dated 12/07/2012
/13/	Order on changes to the line-up of the working team for implementation of the projects aimed at reduction of anthropogenic greenhouse gas emissions dated August 14, 2012, PJSC "Kyivgas"
/14/	Contracts No.1, No.2, No.3, No.4, No.5 on provision of services of monitoring measurements of natural gas leakage at flanged, threaded joints and shut-down devices of PJSC "Kyivgas" pipelines between "Carbon Emission Partnership" LLC and individuals
/15/	Contract № 06/11 on provision of services between "Carbon Emission Partnership" LLC and VEMA S.A. dated 05/04/2011
/16/	Records of field measurements of natural gas leakage volumes at flanged, threaded joints and shut-down devices of PJSC "Kyivgas" pipelines

Persons interviewed:

List persons interviewed during the verification or persons that contributed with other information that are not included in the documents listed above.

	Name	Organization	Position
/1/	Struk O.V.	PJSC "Kyivgas"	Chief Engineer, Working Team Leader
/2/	Krishtofor R.S.	PJSC "Kyivgas"	Head of the department of the legal support of contracting work department of the legal support
/3/	Moshenets D.M.	PJSC "Kyivgas"	Chief of Technical Supervision and operational acceptance facilities supply
/4/	Yuryev D.O.	PJSC "Kyivgas"	Chief Engineer branch operation of gas networks
/5/	Zavhorodniy V.V.	PJSC "Kyivgas"	Senior engineer of Technical Supervision and operational acceptance facilities supply
/6/	Shmagalov O.V.	PJSC "Kyivgas"	Senior Legal Counsel of the department of the legal support of contracting work department of the legal support
/7/	Byelov E.V.	"CEP" LLC	Consultant of VEMA S.A.



VERIFICATION REPORT

APPENDIX A: VERIFICATION PROTOCOL

BUREAU VERITAS CERTIFICATION HOLDING SAS

JI PROJECT VERIFICATION PROTOCOL

Check list for verification, according to the JOINT IMPLEMENTATION DETERMINATION AND VERIFICATION MANUAL (Version 01)

DVM Paragraph	Check Item	Initial finding	Draft Conclusion	Final Conclusion
Project approvals by Parties involved				
90	Has the NFPs of at least one Party involved, other than the host Party, issued a written project approval when submitting the first verification report to the secretariat for publication in accordance with paragraph 38 of the JI guidelines, at the latest?	The project has been approved by both parties. The Letters of Approval were presented to the verification team. CAR 01. Please provide information about determination report of the project.	CAR 01	OK
91	Are all the written project approvals by Parties involved unconditional?	Yes, all the written project approvals by Parties involved are unconditional.	OK	OK
Project implementation				
92	Has the project been implemented in accordance with the PDD regarding which the determination has been deemed final and is so listed on the UNFCCC JI website?	Yes, the project has been implemented in accordance with the PDD, which is listed on the UNFCCC JI website. Project activities include reduction of methane leakage which is the result of faulty sealing of ground and underground fittings implemented at the switch mechanisms (bolts, cocks, valves), flange and threaded joints of gas pipelines of PJSC "Kyivgas" in the amount of 60 613 pieces. Types and quantity of	OK	OK



VERIFICATION REPORT

DVM Paragraph	Check Item	Initial finding	Draft Conclusion	Final Conclusion
		<p>fittings are given in the PDD version 03.</p> <p>During 2005 – 2009 each of 60 613 switch mechanisms (bolts, cocks, valves), flange and threaded joints of gas pipelines of PJSC “Kyivgas” were modernized or repaired.</p> <p>The task of the monitoring period (March 2012 – August 2012) is further accomplishment of purposeful examination and technical maintenance (PETM) of all switch mechanisms (bolts, cocks, valves), flange and threaded joints. Equipment components repaired in 2005-2009 are regularly checked during current monitoring period as a part of a standard monitoring program to make sure they have not become the source of leakage again.</p> <p>According to Monitoring Plan in PDD version 3 the regular maintenance of the components is done once per year, technical maintenance – once per half year.</p> <p>The resulting measurement volumes of methane leakage from repaired PJSC "Kiyivgas" pipelines equipment do not exceed the volumes of leakage, which were measured after the first repair of the equipment.</p>		
93	What is the status of operation of the project during the monitoring period?	<p>The Project has been operational for the whole monitoring period, which is 01/03/2012 – 31/08/2012.</p> <p>CAR 02. GHG emission is not correctly specified in Table 1. Section A.3.</p>	CAR 02	OK
Compliance with monitoring plan				



VERIFICATION REPORT

DVM Paragraph	Check Item	Initial finding	Draft Conclusion	Final Conclusion
94	Did the monitoring occur in accordance with the monitoring plan included in the PDD regarding which the determination has been deemed final and is so listed on the UNFCCC JI website?	Yes, the monitoring was carried out in accordance with the monitoring plan included in the PDD regarding which the determination has been deemed final and is so listed on the UNFCCC JI website. CAR 03. The monitoring period is not correctly specified in Section A.6. of MR.	CAR 03	OK
95 (a)	For calculating the emission reductions or enhancements of net removals, were key factors, e.g. those listed in 23 (b) (i)-(vii) above, influencing the baseline emissions or net removals and the activity level of the project and the emissions or removals as well as risks associated with the project taken into account, as appropriate?	To calculate the emission reductions such key factors as the rate of leakage for each leakage found, gas temperature and pressure, volume of capacity, the concentration of methane in the sample, the time for which the concentration of methane in the volume capacity reaches a certain level, experience in implementing measures envisaged by the project, the current practice that exists in Ukraine in this area, financial costs and the availability of expertise, legislation affecting the emissions in the baseline, level of activity on the project and the project emissions and risks associated with the project were taken into consideration.	OK	OK
95 (b)	Are data sources used for calculating emission reductions or enhancements of net removals clearly identified, reliable and transparent?	Yes, data sources used for calculating emission reductions or enhancements of net removals are clearly identified, reliable and transparent CAR 04. Please specify the baseline, project emissions and emission reductions in tonnes of CO ₂ equivalent. CAR 05. Table 2 of Section B.2.2 doesn't provide	CAR 04 CAR 05	OK OK



VERIFICATION REPORT

DVM Paragraph	Check Item	Initial finding	Draft Conclusion	Final Conclusion
		source of data for GWP _{CH4} parameter.		
95 (c)	Are emission factors, including default emission factors, if used for calculating the emission reductions or enhancements of net removals, selected by carefully balancing accuracy and reasonableness, and appropriately justified of the choice?	Yes, emission factors, including default emission factors, that are used for calculating the emission reductions or enhancements of net removals, are selected by carefully balancing accuracy and reasonableness, and appropriately justified of the choice.	OK	OK
95 (d)	Is the calculation of emission reductions or enhancements of net removals based on conservative assumptions and the most plausible scenarios in a transparent manner?	The emission reductions calculation is based on conservative assumptions and the most plausible scenarios in a transparent manner.	OK	OK
Applicable to JI SSC projects only				
96	Is the relevant threshold to be classified as JI SSC project not exceeded during the monitoring period on an annual average basis? If the threshold is exceeded, is the maximum emission reduction level estimated in the PDD for the JI SSC project or the bundle for the monitoring period determined?	N/a	N/a	N/a
Applicable to bundled JI SSC projects only				
97 (a)	Has the composition of the bundle not changed from that is stated in F-JI-	N/a	N/a	N/a



VERIFICATION REPORT

DVM Paragraph	Check Item	Initial finding	Draft Conclusion	Final Conclusion
	SSCBUNDLE?			
97 (b)	If the determination was conducted on the basis of an overall monitoring plan, have the project participants submitted a common monitoring report?	N/a	N/a	N/a
98	If the monitoring is based on a monitoring plan that provides for overlapping monitoring periods, are the monitoring periods per component of the project clearly specified in the monitoring report? Do the monitoring periods not overlap with those for which verifications were already deemed final in the past?	N/a	N/a	N/a
Revision of monitoring plan				
Applicable only if monitoring plan is revised by project participant				
99 (a)	Did the project participants provide an appropriate justification for the proposed revision?	N/a	N/a	N/a
99 (b)	Does the proposed revision improve the accuracy and/or applicability of information collected compared to the original monitoring plan without changing conformity with the relevant rules and regulations for the establishment of monitoring plans?	N/a	N/a	N/a
Data management				
101 (a)	Is the implementation of data collection procedures in accordance with the	CAR 06. Please provide the Order on changes in the line-up of the working team.	CAR 06	OK



VERIFICATION REPORT

DVM Paragraph	Check Item	Initial finding	Draft Conclusion	Final Conclusion
	monitoring plan, including the quality control and quality assurance procedures?			
101 (b)	Is the function of the monitoring equipment, including its calibration status, is in order?	Yes, the function of the monitoring equipment, including its calibration status is in order. CAR 07. Please provide the Calibration certificate of the equipment for measuring of the leaks.	CAR 07	OK
101 (c)	Are the evidence and records used for the monitoring maintained in a traceable manner?	Yes, the evidence and records used for the monitoring are maintained in a traceable manner.	OK	OK
101 (d)	Is the data collection and management system for the project in accordance with the monitoring plan?	The data collection and management system for the project is in accordance with the monitoring plan. Verification Team confirms the effectiveness of existing management system and operating system and considers them suitable for reliable monitoring of the project. CL 01. Please check the numbering of Tables and Figures in the MR.	CL 01	OK
Verification regarding programs of activities (additional elements for assessment)				
102	Is any JPA that has not been added to the JI PoA not verified?	N/a	N/a	N/a
103	Is the verification based on the monitoring reports of all JPAs to be verified?	N/a	N/a	N/a
103	Does the verification ensure the accuracy and conservativeness of the emission reductions or enhancements of removals generated by each JPA?	N/a	N/a	N/a
104	Does the monitoring period not overlap with	N/a	N/a	N/a



VERIFICATION REPORT

DVM Paragraph	Check Item	Initial finding	Draft Conclusion	Final Conclusion
	previous monitoring periods?			
105	If the AIE learns of an erroneously included JPA, has the AIE informed the JISC of its findings in writing?	N/a	N/a	N/a
Applicable to sample-based approach only				
106	<p>Does the sampling plan prepared by the AIE:</p> <p>(a) Describe its sample selection, taking into account that:</p> <p>(i) For each verification that uses a sample-based approach, the sample selection shall be sufficiently representative of the JPAs in the JI Project. Such extrapolation to all JPAs identified for that verification is reasonable, taking into account differences among the characteristics of JPAs, such as:</p> <ul style="list-style-type: none"> - The types of JPAs; - The complexity of the applicable technologies and/or measures used; - The geographical location of each JPA; - The amounts of expected emission reductions of the JPAs being verified; - The number of JPAs for which emission reductions are being verified; 	N/a	N/a	N/a



VERIFICATION REPORT

DVM Paragraph	Check Item	Initial finding	Draft Conclusion	Final Conclusion
	<ul style="list-style-type: none"> - The length of monitoring periods of the JPAs being verified; and - The samples selected for prior verifications, if any? 			
107	Is the sampling plan ready for publication through the secretariat along with the verification report and supporting documentation?	N/a	N/a	N/a
108	Has the AIE made site inspections of at least the square root of the number of total JPAs, rounded to the upper whole number? If the AIE makes no site inspections or fewer site inspections than the square root of the number of total JPAs, rounded to the upper whole number, then does the AIE provide a reasonable explanation and justification?	N/a	N/a	N/a
109	Is the sampling plan available for submission to the secretariat for the JISC.s ex ante assessment? (Optional)	N/a	N/a	N/a
110	If the AIE learns of a fraudulently included JPA, a fraudulently monitored JPA or an inflated number of emission reductions claimed in a JI PoA, has the AIE informed	N/a	N/a	N/a

VERIFICATION REPORT



DVM Paragraph	Check Item	Initial finding	Draft Conclusion	Final Conclusion
	the JISC of the fraud in writing?			

**TABLE 2 RESOLUTION OF CLARIFICATION AND CORRECTIVE ACTION REQUESTS**

Draft report clarifications and corrective action requests by validation team	Ref. to checklist question in table 1	Summary of project participant response	Verification team conclusion
CAR 01. Please provide information about determination report of the project.	90	JI project "Reduction of Methane Emissions at Flanged, Threaded Joints and Shut-down Devices of OJSC "Kyivgas" Equipment» was determined by the Bureau Veritas Certification, determination report No. UKRAINE/0125/2010 as of 08/07/2010.	The issue is closed based on information provided.
CAR 02. GHG emission is not correctly specified in Table 1. Section A.3.	93	GHG emission for the monitoring period is 566 333 tCO ₂ e.	The issue is closed based on making the necessary changes.
CAR 03. The monitoring period is not correctly specified in Section A.6. of MR.	94	The monitoring period is 01/03/2012 – 31/08/2012. The necessary corrections were made in Section A.6.	The references were checked, the issue is closed.
CAR 04. Please specify the baseline, project emissions and emission reductions in tonnes of CO ₂ equivalent.	95 (b)	Necessary corrections were made in the MR version 02.	The issue is closed based on making the necessary changes.
CAR 05. Table 2 of Section B.2.2 doesn't provide source of data for GWP _{CH₄} parameter.	95 (b)	The source of data for GWP _{CH₄} parameter is IPCC.	The issue is closed based on making the necessary changes.



VERIFICATION REPORT

CAR 06. Please provide the Order on changes in the line-up of the working team.	101 (a)	The order was provided to the verification team.	The issue is closed based on providing appropriate documentation.
CAR 07. Please provide the Calibration certificate of the equipment for measuring of the leaks.	101 (b)	The Calibration certificate was provided to the verification team.	The issue is closed based on providing appropriate documentation.
CL 01. Please check the numbering of Tables and Figures in the MR.	101 (d)	Appropriate corrections were made in the MR version 02.	The issue is closed based on the changes made.